



**en Schematic Manual**  
**NIGHT-LITE™ V-SERIES**

## TABLE OF CONTENTS

Tail Light Harness Schematic (Old Version) (107266) .....	(1.1)
Front Marker Lights Schematic (107268) .....	(1.2)
Rear Marker Lights Schematic (107493) .....	(1.3)
Tail Light Harness Schematic (New Version) (112266) .....	(1.4)
6/4 50/60Hz 6/8kW Generator Cord Schematic (105269) .....	(1.5)
10/4 50/60Hz 6/8kW Generator Cord Schematic (108909) .....	(1.6)
NLV SLS Relay Schematic (113468) .....	(1.7)
NLV LSC 2.1 Transformer Schematic (113437) .....	(1.8)
Mitsubishi L3E Engine Harness Schematic (108042) .....	(1.9)
Kubota D1005 Engine Harness Schematic (108044) .....	(1.10)
CAT/Perkins 1.1L Engine Harness Schematic (110112) .....	(1.11)
SLS / Key Start Schematic (110123) .....	(1.12)
LSC / SLS Schematic (113652) .....	(1.13)
Fuel/Hour Gauge Schematic (113659) .....	(1.14)
1-GFCI, 1-4 Prong Twistlock NLV Outlet Panel Schematic (112037) .....	(1.15)
1-GFCI, 1-30A RV, 1-3 Prong Twistlock NLV Outlet Schematic (113472) .....	(1.16)
1-GFCI, 1-30A RV, 1-4 Prong Twistlock NLV Outlet Schematic (113473) .....	(1.17)
2-GFCI NLV Outlet Schematic (113860) .....	(1.18)
2-Schuko NLV Outlet Schematic (113475) .....	(1.19)
Main Breaker to Light Switches Schematic (112035) .....	(1.20)
4-Light 4-725 Relay NLV Schematic (Old Version) (112034) .....	(1.21)
4-Light 4-725 Relay NLV Schematic (New Version) (113505) .....	(1.22)
4-Light 4-Zettler Relay NLV Schematic (113583) .....	(1.23)
4-Light 4-LED Relay NLV Schematic (113805) .....	(1.24)
Ballast Cord NLV Schematic (113474) .....	(1.25)

# Night-Lite V-Series

## TABLE OF CONTENTS

1000W 60Hz 120V Ballast Schematic (105287) .....	(1.26)
1000W 50Hz 120V Ballast Schematic (105288) .....	(1.27)
1250W 60Hz 120V Ballast Schematic (105286) .....	(1.28)
LED Drivers NLV Schematic (113621) .....	(1.29)
4-Metal Halide Lamps Light Bar Schematic (112039) .....	(1.30)
4-LED Lamps Light Bar Schematic (113750) .....	(1.31)
C1000 Electric Winch NLV Schematic (Old Version) (110117) .....	(1.32)
C1000 Electric Winch NLV Schematic (New Version) (117147) .....	(1.33)
SH 1000 Electric Winch NLV Schematic (117537) .....	(1.34)
Deep Sea L401 Schematic .....	(1.35)
Remote Start Deep Sea L401 Schematic .....	(1.36)

## WIRE SCHEMATIC PAGE CONNECTION TABLE

Schematic Page	1st Connection Page(s)	2nd Connection Page(s)	3rd Connection Page(s)	4th Connection Page(s)
Tail Light Harness Schematic (Old Version) (1.1)	(1.3)	n/a	n/a	n/a
Front Marker Lights Schematic (1.2)	(1.3)	n/a	n/a	n/a
Rear Marker Lights Schematic (1.3)	(1.1)	(1.2)	n/a	n/a
Tail Light Harness Schematic (New Version) (1.4)	n/a	n/a	n/a	n/a
6/4 50/60Hz 6/8kW Generator Cord Schematic (1.5)	(1.7) or (1.8)	n/a	n/a	n/a
10/4 50/60Hz 6/8kW Generator Cord Schematic (1.6)	(1.7) or (1.8)	n/a	n/a	n/a
NLV SLS Relay Schematic (1.7)	(1.5) or (1.6)	(1.15), (1.16), (1.17), (1.18), (1.19), or (1.20)	(1.12)	(1.12)
NLV LSC 2.1 Transformer Schematic (1.8)	(1.5) or (1.6)	(1.15), (1.16), (1.17), (1.18), (1.19), or (1.20)	(1.13)	n/a
Mitsubishi L3E Engine Harness Schematic (1.9)	(1.12) or (1.13)	(1.12) or (1.13)	(1.12) or (1.13)	(1.13)
Kubota D1005 Engine Harness Schematic (1.10)	(1.12) or (1.13)	(1.12) or (1.13)	(1.12) or (1.13)	(1.13)
CAT/Perkins 1.1L Harness Schematic (1.11)	(1.12) or (1.13)	(1.12) or (1.13)	(1.12) or (1.13)	(1.13)

# Night-Lite V-Series

## WIRE SCHEMATIC PAGE CONNECTION TABLE

Schematic Page	1st Connection Page(s)	2nd Connection Page(s)	3rd Connection Page(s)	4th Connection Page(s)
SLS / Key Start Schematic (1.12)	(1.9), (1.10), or (1.11)	(1.9), (1.10), or (1.11)	(1.9), (1.10), or (1.11)	(1.7)
LSC / SLS Schematic (1.13)	(1.9), (1.10), or (1.11)	(1.9), (1.10), or (1.11)	(1.9), (1.10), or (1.11)	(1.9), (1.10), or (1.11)

Schematic Page	5th Connection Page(s)	6th Connection Page(s)	7th Connection Page(s)	8th Connection Page(s)
SLS / Key Start Schematic (1.12)	(1.7)	(1.14)	(1.14), (1.32), (1.33), or (1.34)	(1.21), (1.22), (1.23), or (1.24)
LSC / SLS Schematic (1.13)	(1.8)	(1.32), (1.33), or (1.34)	(1.21), (1.22), (1.23), or (1.24)	n/a

Schematic Page	1st Connection Page(s)	2nd Connection Page(s)	3rd Connection Page(s)	4th Connection Page(s)
Fuel / Hour Gauge Schematic (1.14)	(1.12)	(1.12)	n/a	n/a
1-GFCI, 1-4 Prong Twistlock NLV Outlet Panel Schematic (1.15)	(1.7) or (1.8)	n/a	n/a	n/a
1-GFCI, 1-30A RV, 1-3 Prong Twistlock NLV Outlet Schematic (1.16)	(1.7) or (1.8)	n/a	n/a	n/a
1-GFCI, 1-30A RV, 1-4 Prong Twistlock NLV Outlet Schematic (1.17)	(1.7) or (1.8)	n/a	n/a	n/a

## WIRE SCHEMATIC PAGE CONNECTION TABLE

Schematic Page	1st Connection Page(s)	2nd Connection Page(s)	3rd Connection Page(s)	4th Connection Page(s)
2-GFCI NLV Outlet Schematic (1.18)	(1.7) or (1.8)	n/a	n/a	n/a
2-Schuko NLV Outlet Schematic (1.19)	(1.7) or (1.8)	n/a	n/a	n/a
Main Breaker to Light Switches Schematic (1.20)	(1.7) or (1.8)	(1.21), (1.22), or (1.23)	n/a	n/a
4-Light 4-725 Relay NLV Schematic (Old Version) (1.21)	(1.12) or (1.13)	(1.20)	(1.25)	n/a
4-Light 4-725 Relay NLV Schematic (New Version) (1.22)	(1.12) or (1.13)	(1.20)	(1.25)	n/a
4-Light 4-Zettler Relay NLV Schematic (1.23)	(1.12) or (1.13)	(1.20)	(1.25)	n/a
4-Light 4-LED Relay NLV Schematic (1.24)	(1.12) or (1.13)	(1.20)	(1.29)	n/a
Ballast Cord NLV Schematic (1.25)	(1.21), (1.22), or (1.23)	(1.26), (1.27), or (1.28)	(1.30)	n/a
1000W 60Hz 120V Schematic (1.26)	(1.25)	n/a	n/a	n/a
1000W 50Hz 120V Schematic (1.27)	(1.25)	n/a	n/a	n/a
1250W 60Hz 120V Schematic (1.28)	(1.25)	n/a	n/a	n/a

# Night-Lite V-Series

## WIRE SCHEMATIC PAGE CONNECTION TABLE

Schematic Page	1st Connection Page(s)	2nd Connection Page(s)	3rd Connection Page(s)	4th Connection Page(s)
LED Drivers NLV Schematic (1.29)	(1.24)	(1.31)	n/a	n/a
4-Metal Halide Lamps Light Bar Schematic (1.30)	(1.25)	n/a	n/a	n/a
4-LED Lamps Light Bar Schematic (1.31)	(1.29)	n/a	n/a	n/a
C1000 Electric Winch NLV Schematic (Old Version) (1.32)	(1.12) or (1.13)	n/a	n/a	n/a
C1000 Electric Winch NLV Schematic (New Version) (1.33)	(1.12) or (1.13)	n/a	n/a	n/a
SH 1000 Electric Winch NLV Schematic (1.34)	(1.12) or (1.13)	n/a	n/a	n/a

Schematic Page	1st Connection Page(s)	2nd Connection Page(s)	3rd Connection Page(s)	4th Connection Page(s)
Deep Sea L401 Schematic (1.35)	(1.9), (1.10), or (1.11)	(1.9), (1.10), or (1.11)	(1.9), (1.10), or (1.11)	(1.9), (1.10), or (1.11)

Schematic Page	5th Connection Page(s)	6th Connection Page(s)	7th Connection Page(s)	8th Connection Page(s)
Deep Sea L401 Schematic (1.35)	(1.36)	(1.34)	(1.21), (1.22), (1.23), or (1.24)	n/a

Schematic Page	1st Connection Page(s)	2nd Connection Page(s)	3rd Connection Page(s)	4th Connection Page(s)
Deep Sea L401 Schematic (1.36)	(1.35)	n/a	n/a	n/a

## 1.1 - Tail Light Harness Schematic (Old Version)

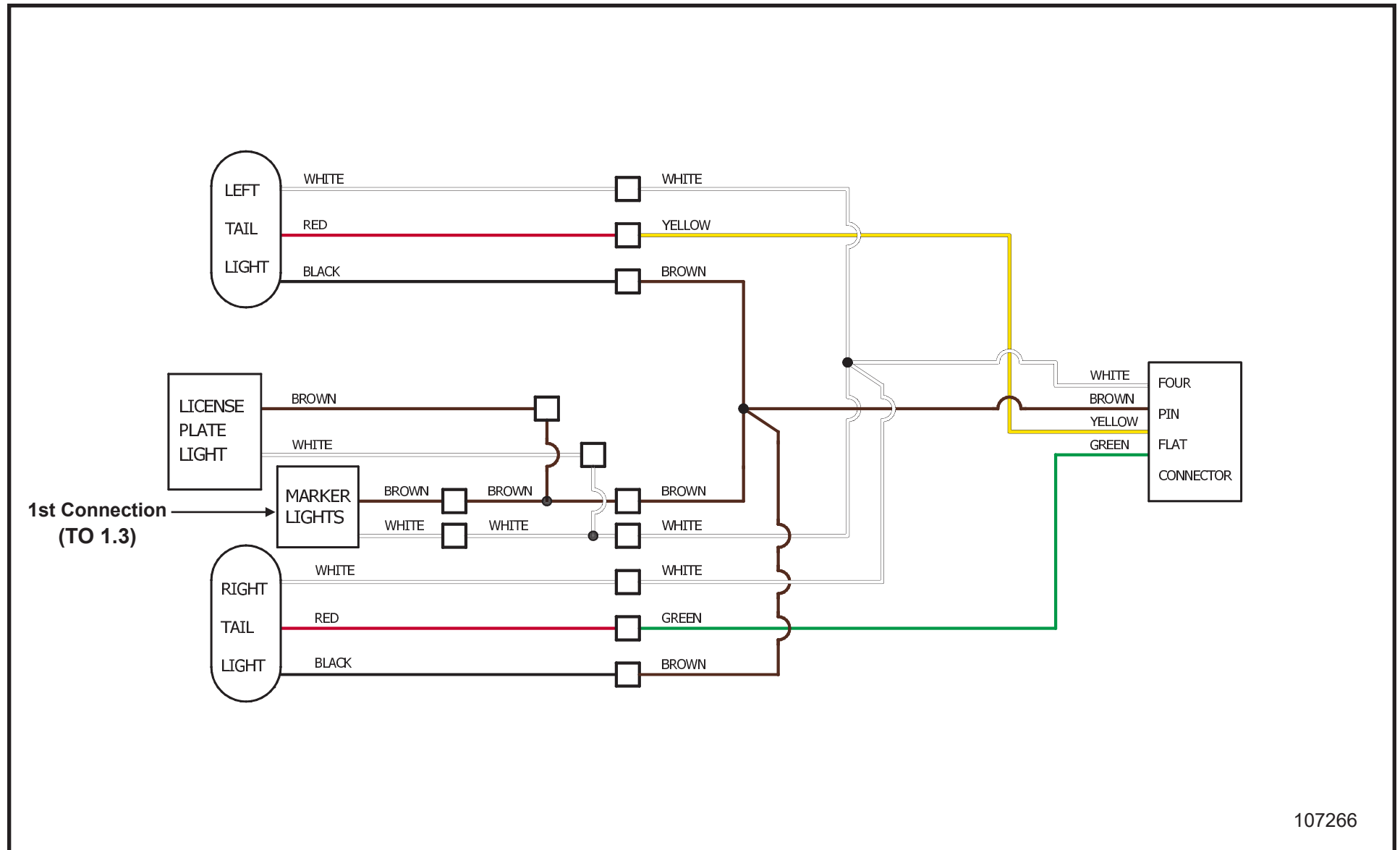

107266

# Night-Lite V-Series

## 1.2 - Front Marker Lights Schematic

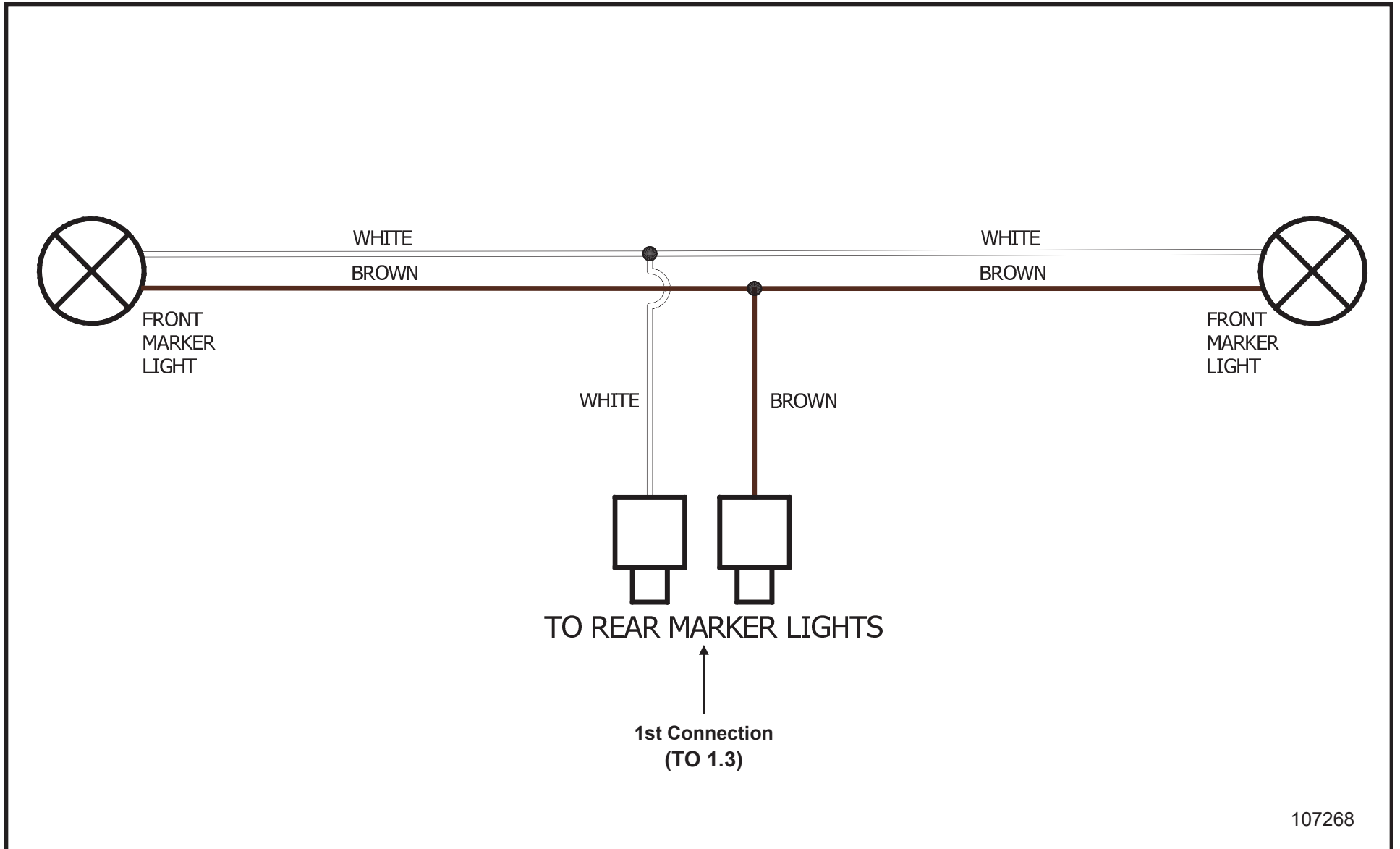

## 1.3 - Rear Marker Lights Schematic

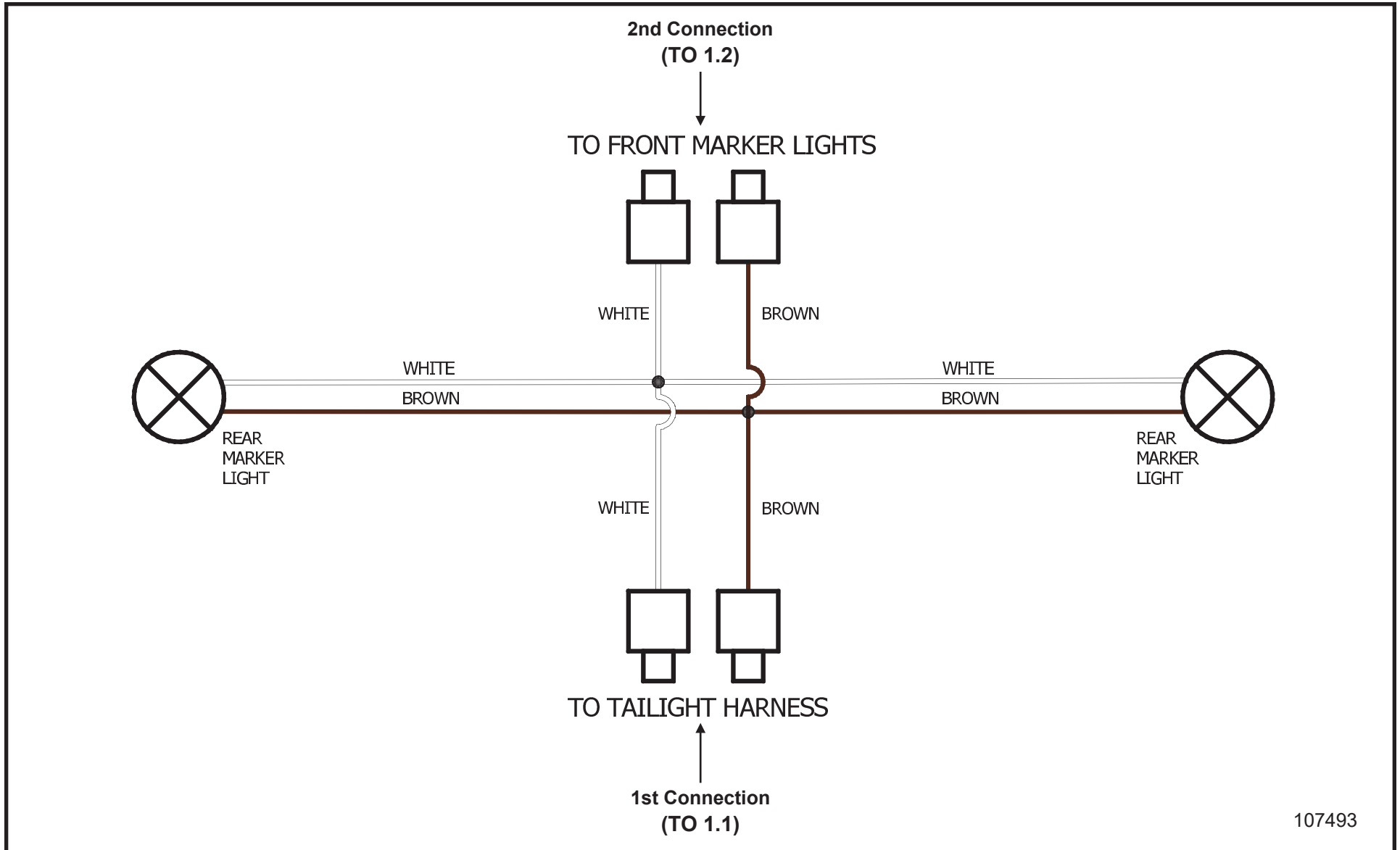

107493

# Night-Lite V-Series

## 1.4 - Tail Light Harness Schematic (New Version)

No Connections

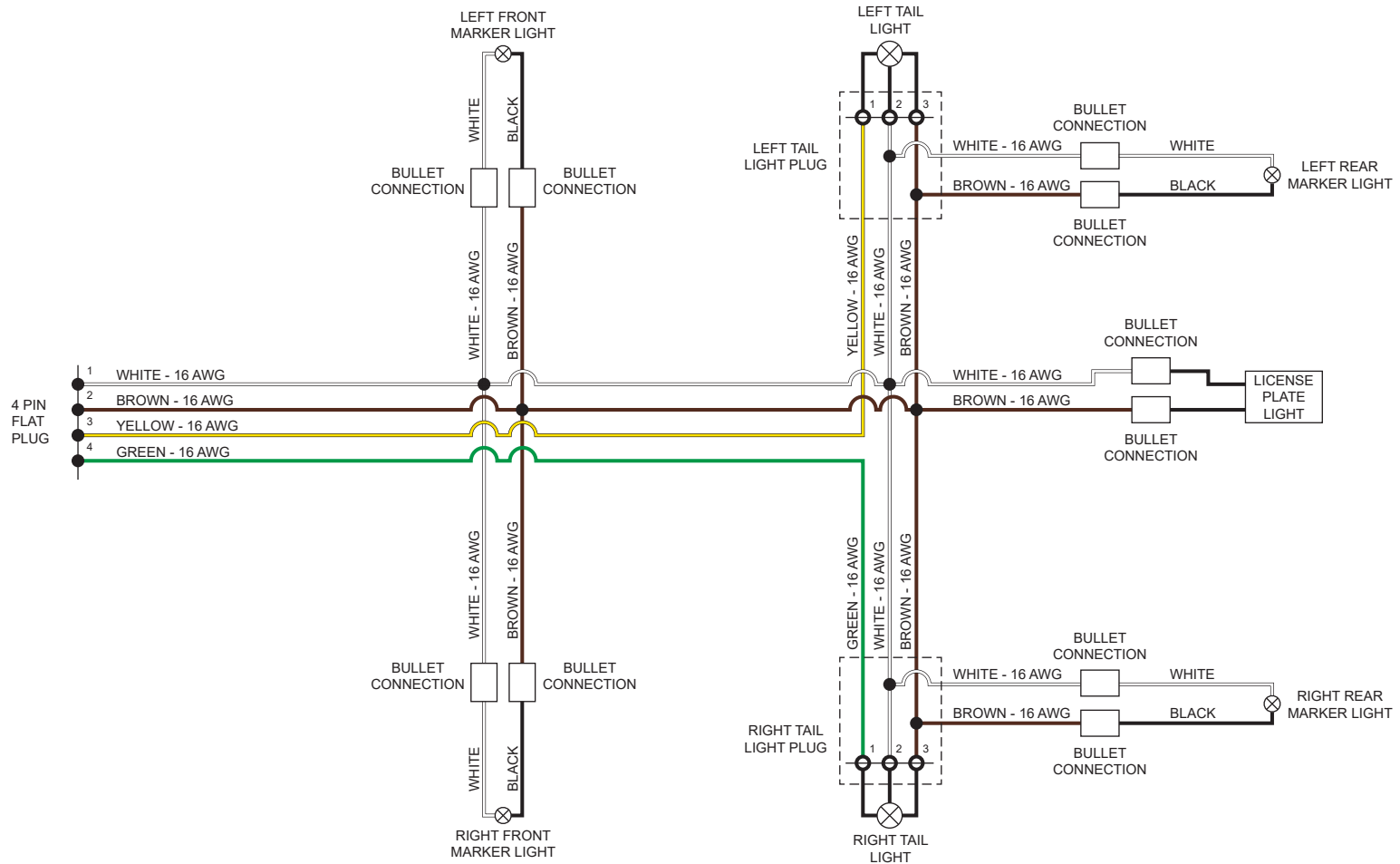

112266

## 1.5 - 6/4 50/60Hz 6/8kW Generator Cord Schematic

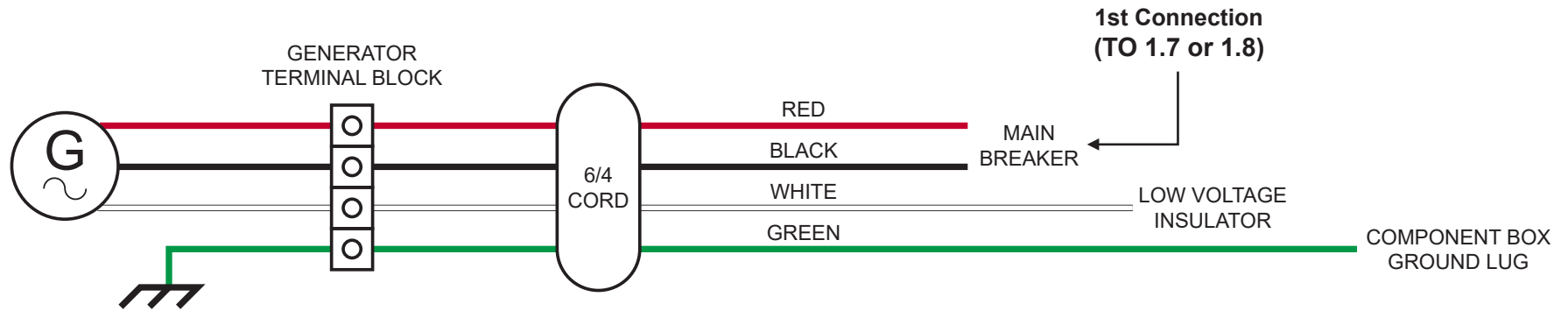

GENERATOR TERMINAL BLOCK CONNECTIONS				
6/4 CORD WIRE	MARATHON 50/60 Hz	ATHLON 50/60 Hz	COLISEUM 60 Hz	COLISEUM 50 Hz
RED	3	L1	11	11
WHITE	2	L2	33	33
BLACK	1	L3	44	66
GREEN	GROUND STUD	GROUND STUD	22	55

105269

# Night-Lite V-Series

## 1.6 - 10/4 50/60Hz 6/8kW Generator Cord Schematic

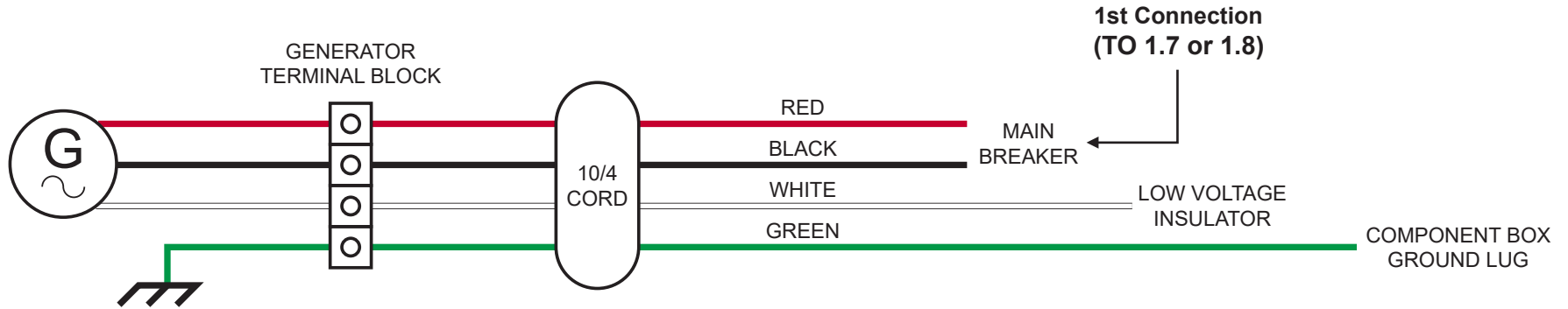

GENERATOR TERMINAL BLOCK CONNECTIONS				
10/4 CORD WIRE	MARATHON 50/60 Hz	ATHLON 50/60 Hz	COLISEUM 60 Hz	COLISEUM 50 Hz
RED	3	L1	11	11
WHITE	2	L2	33	33
BLACK	1	L3	44	66
GREEN	GROUND STUD	GROUND STUD	22	55

108909

## 1.7 - NLV SLS Relay Schematic

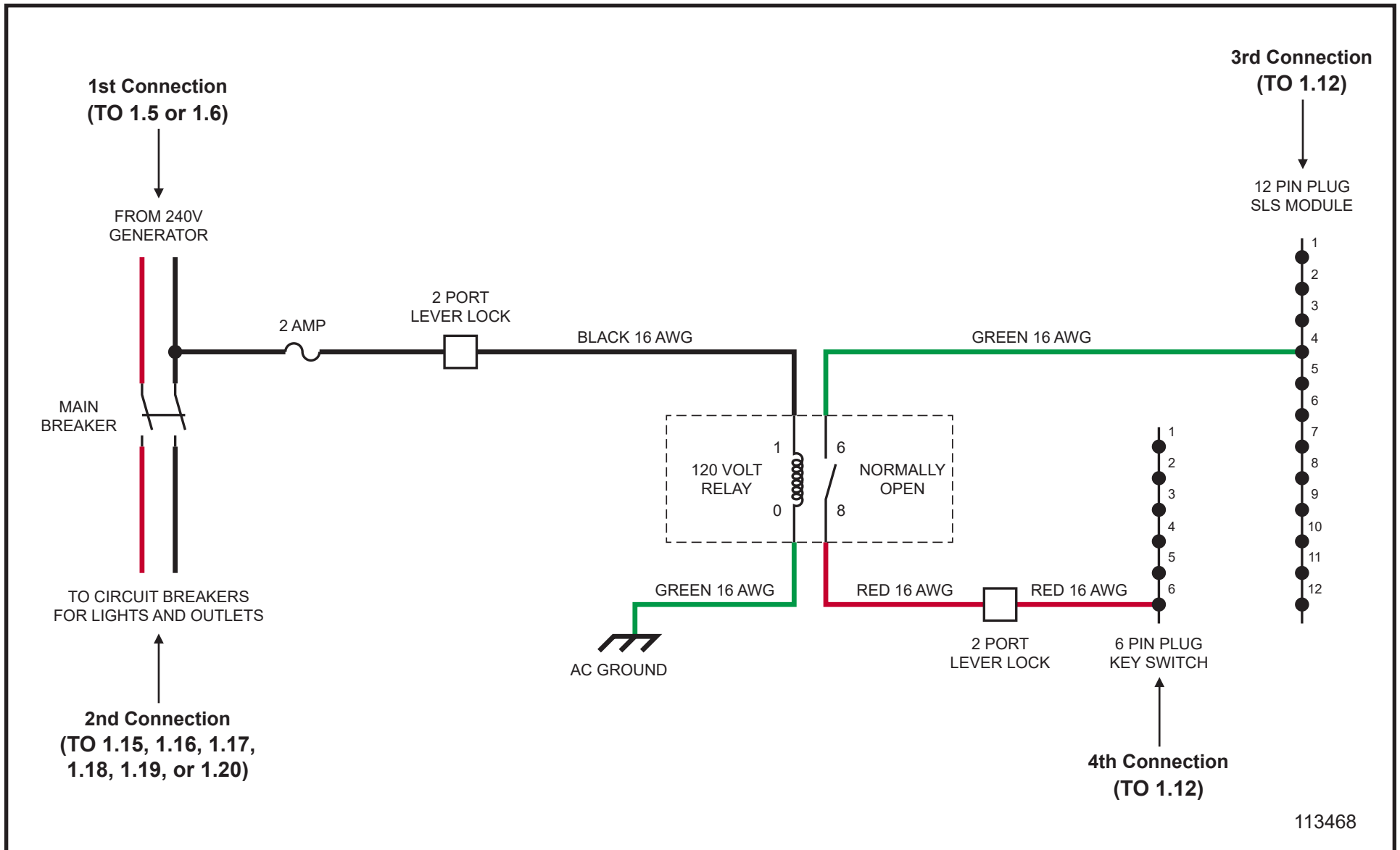

# Night-Lite V-Series

## 1.8 - NLV LSC 2.1 Transformer Schematic

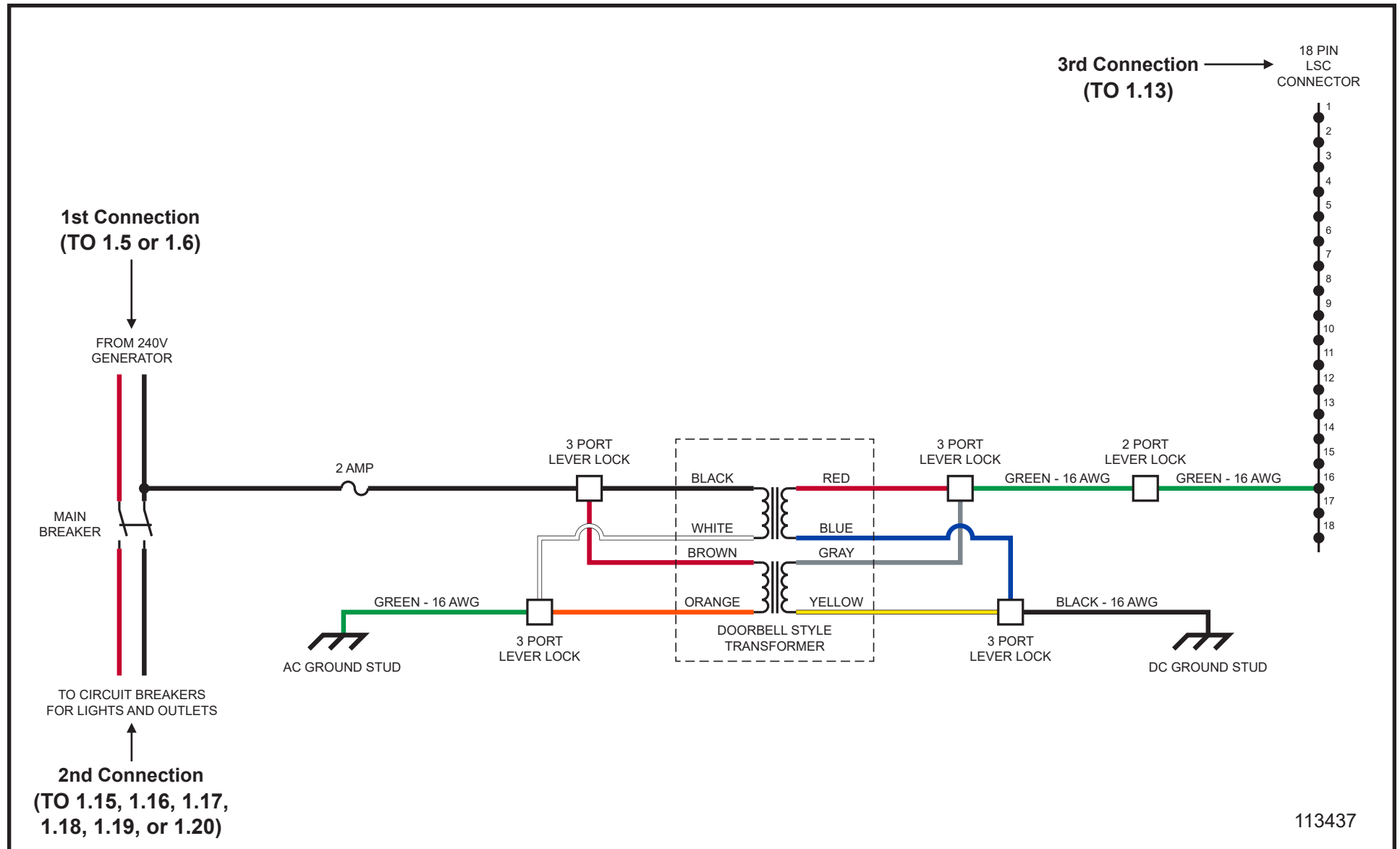

## 1.9 - Mitsubishi L3E Engine Harness Schematic

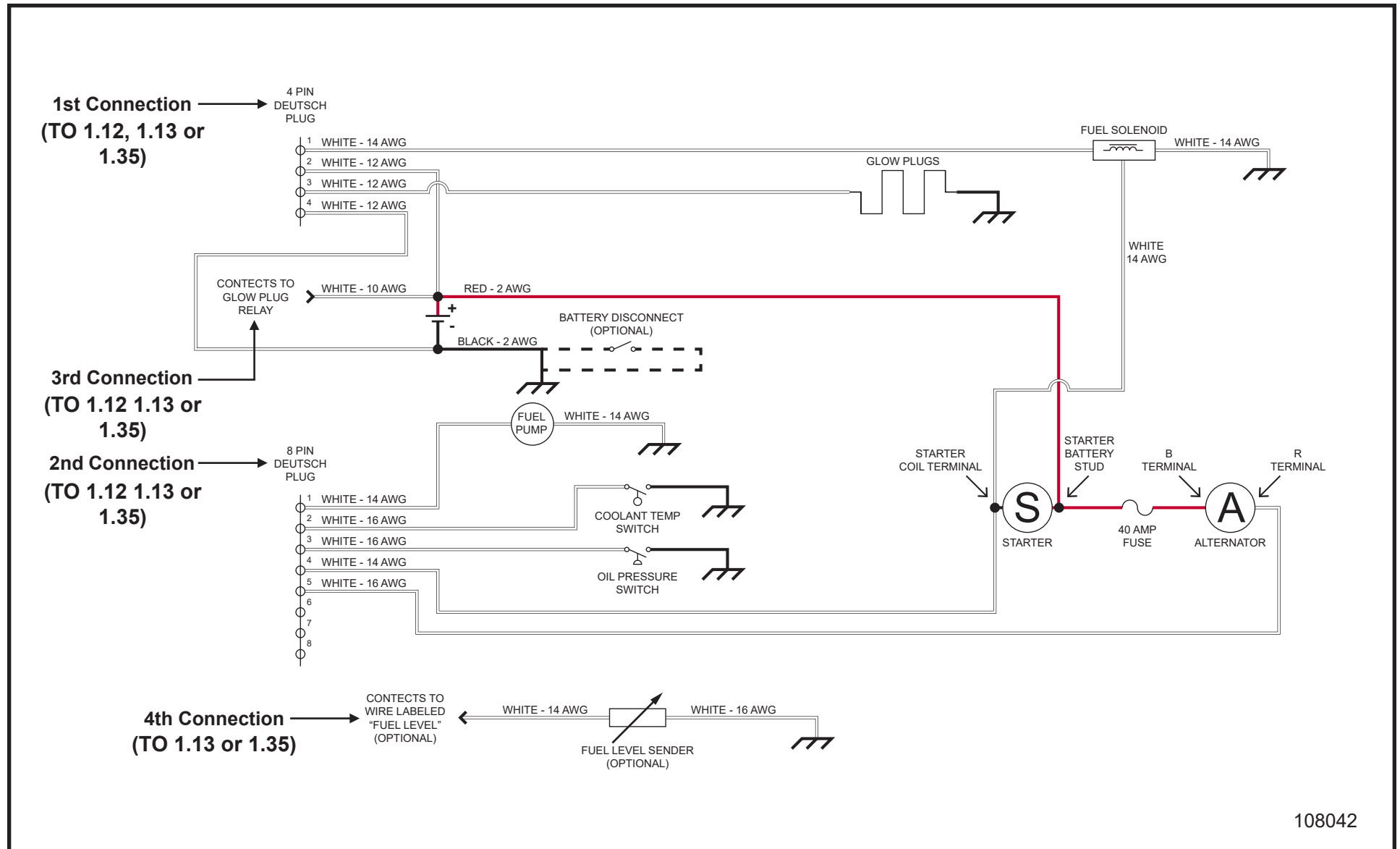

108042

# Night-Lite V-Series

## 1.10 - Kubota D1005 Engine Harness Schematic

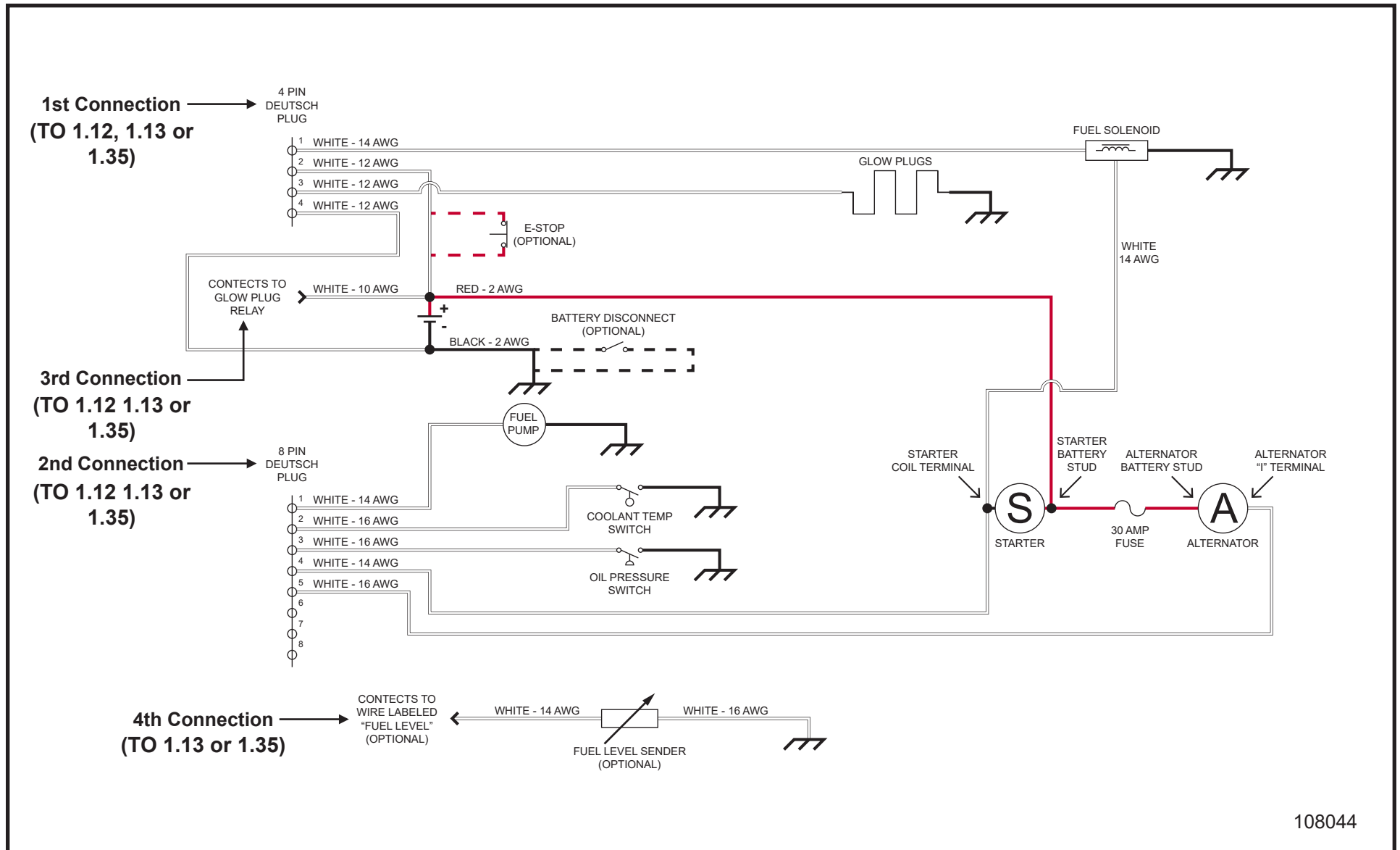

108044

## 1.11 - CAT/Perkins 1.1L Harness Schematic

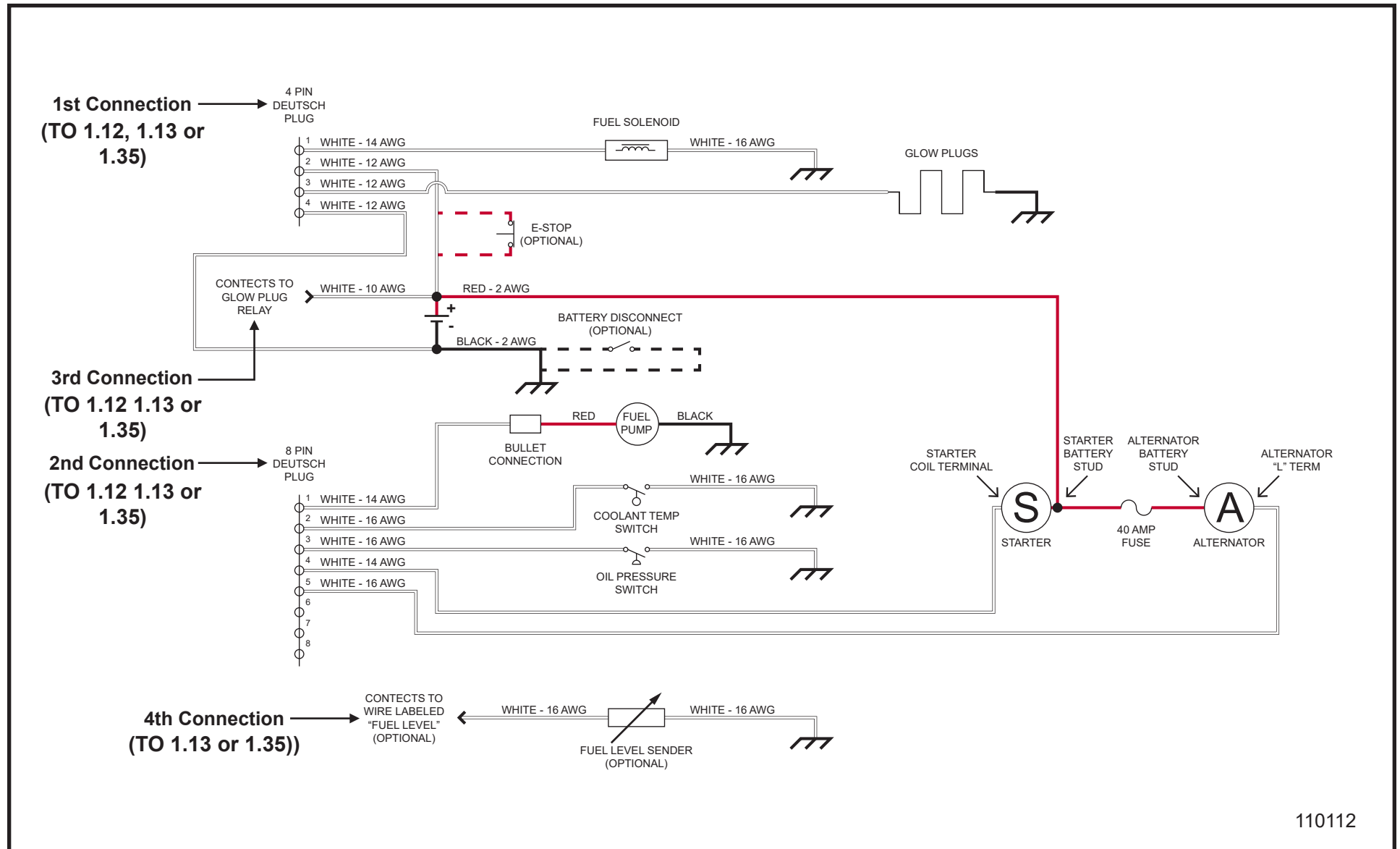

110112



## 1.13 - LSC / SLS Schematic

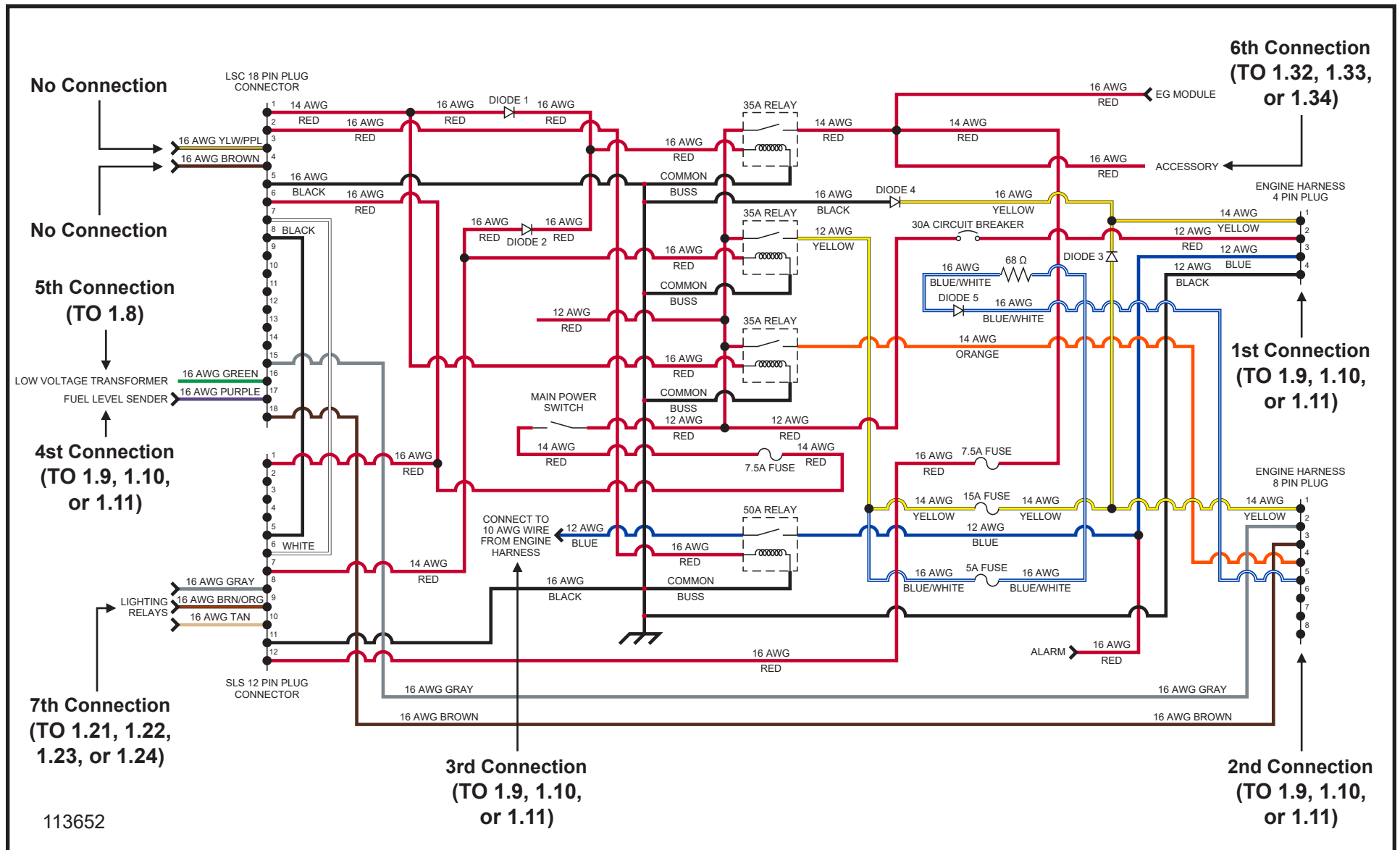

# Night-Lite V-Series

## 1.14 - Fuel / Hour Gauge Schematic

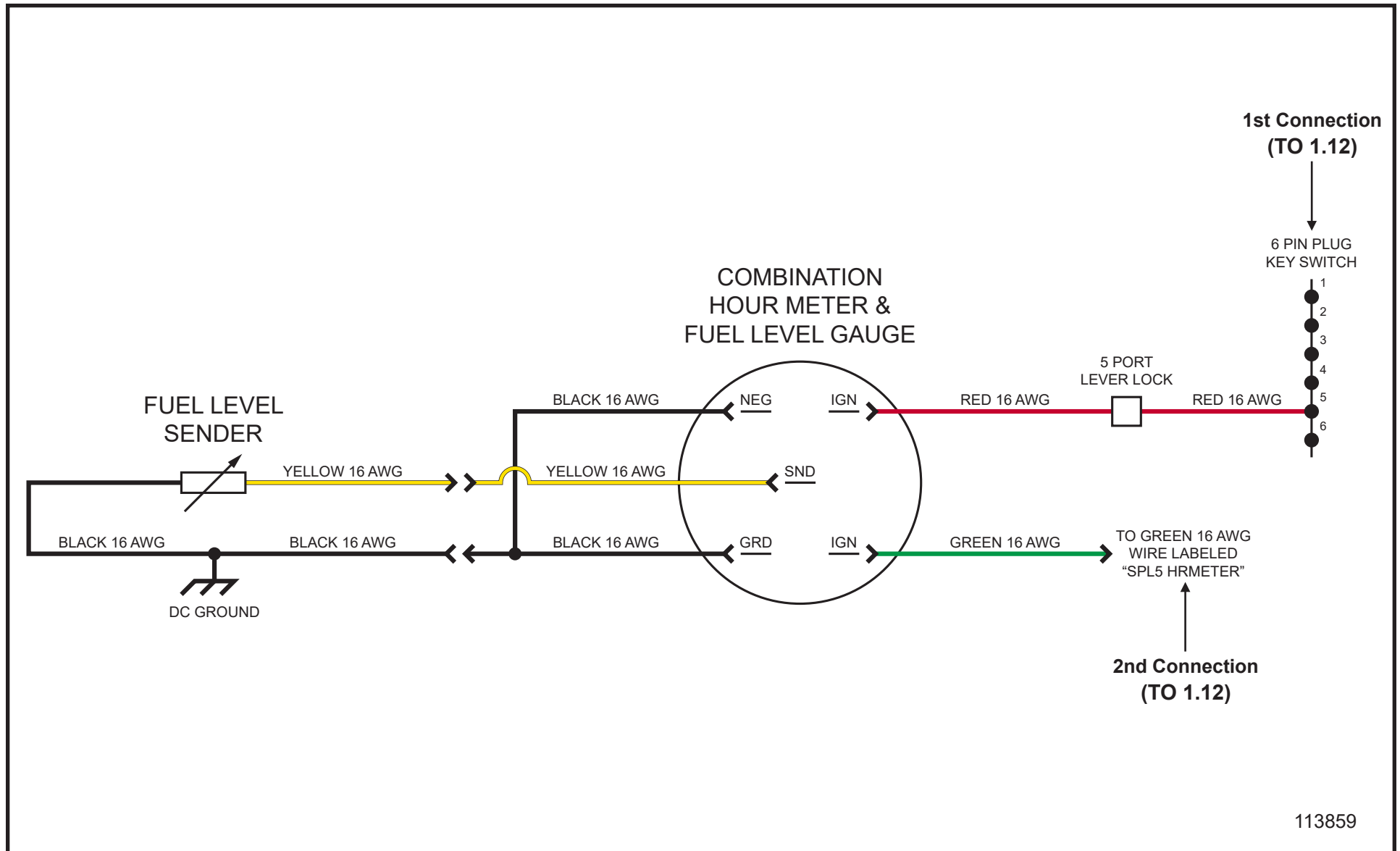

## 1.15 - 1-GFCI, 1-4 Prong Twistlock NLV Outlet Panel Schematic

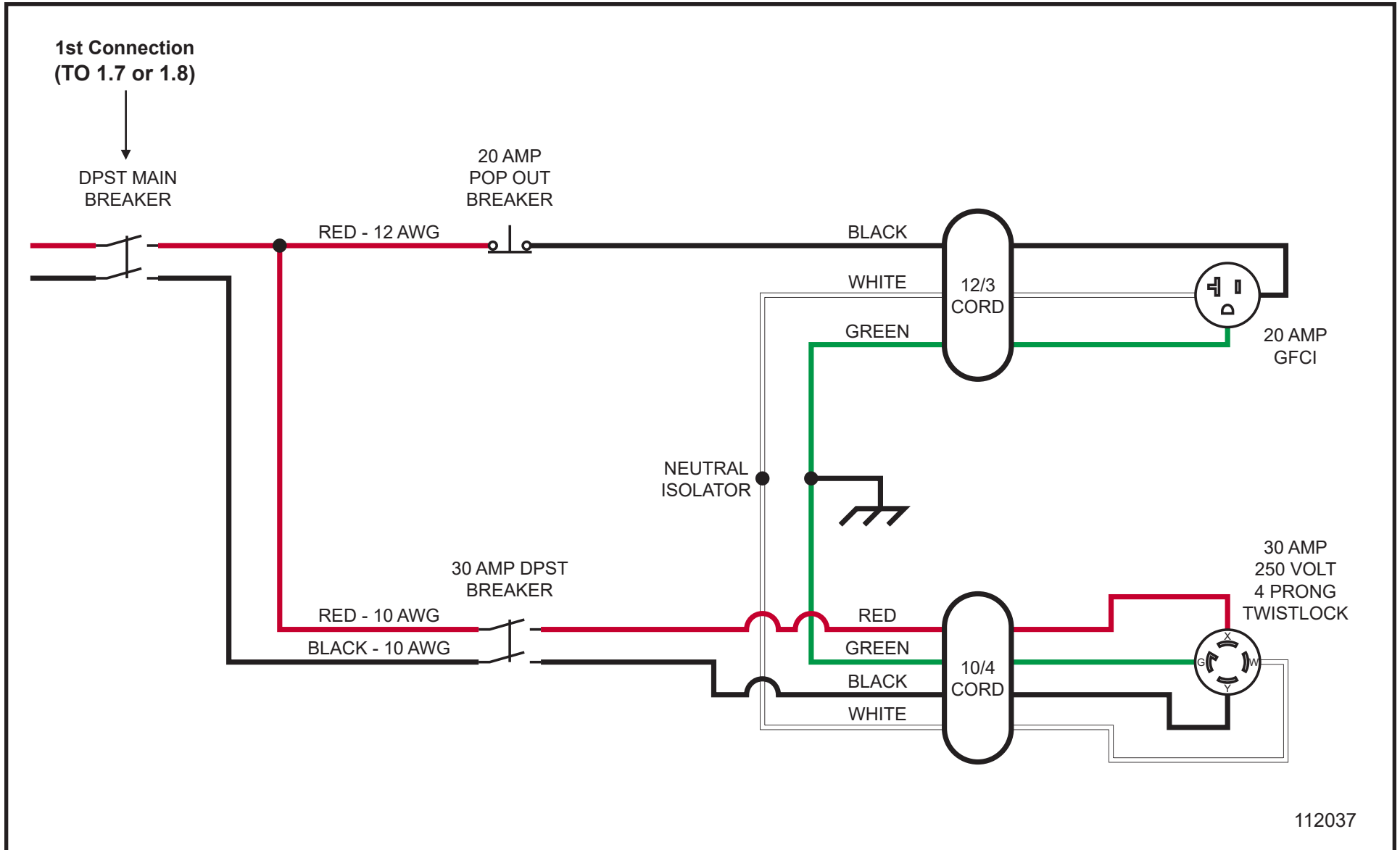

# Night-Lite V-Series

## 1.16 - 1-GFCI, 1-30A RV, 1-3 Prong Twistlock NLV Outlet Schematic

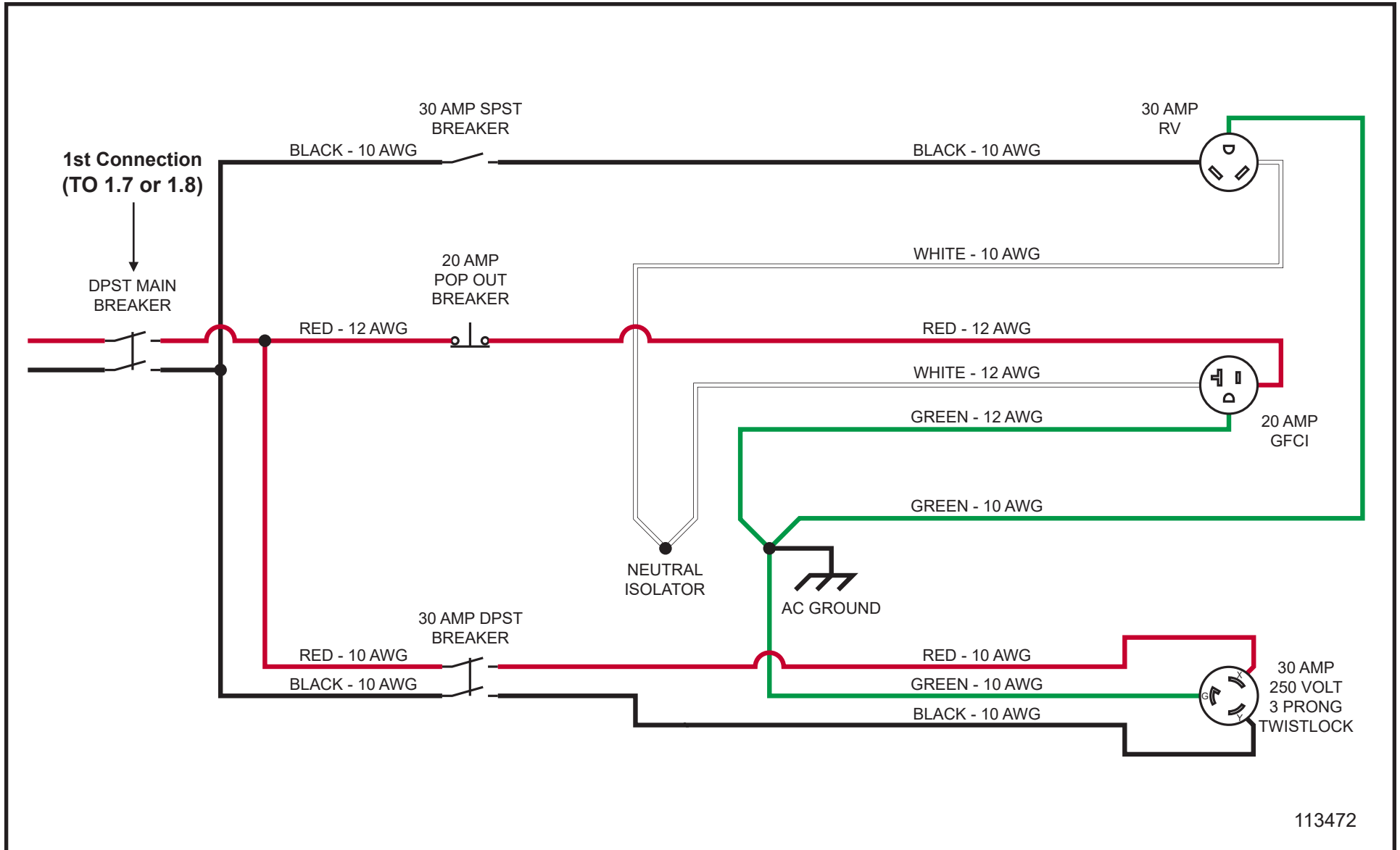

## 1.17 - 1-GFCI, 1-30A RV, 1-4 Prong Twistlock NLV Outlet Schematic

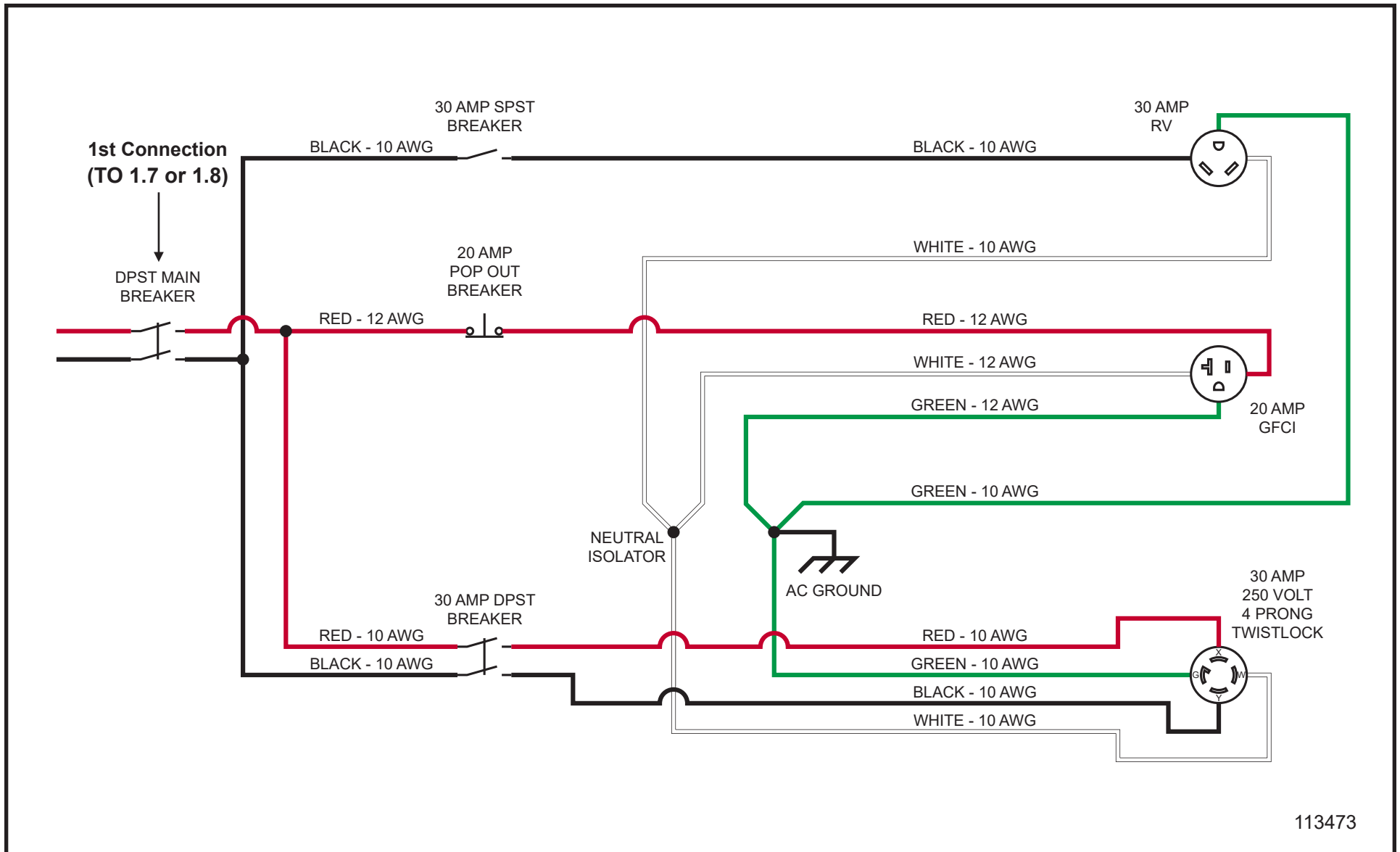

# Night-Lite V-Series

## 1.18 - 2-GFCI NLV Outlet Schematic

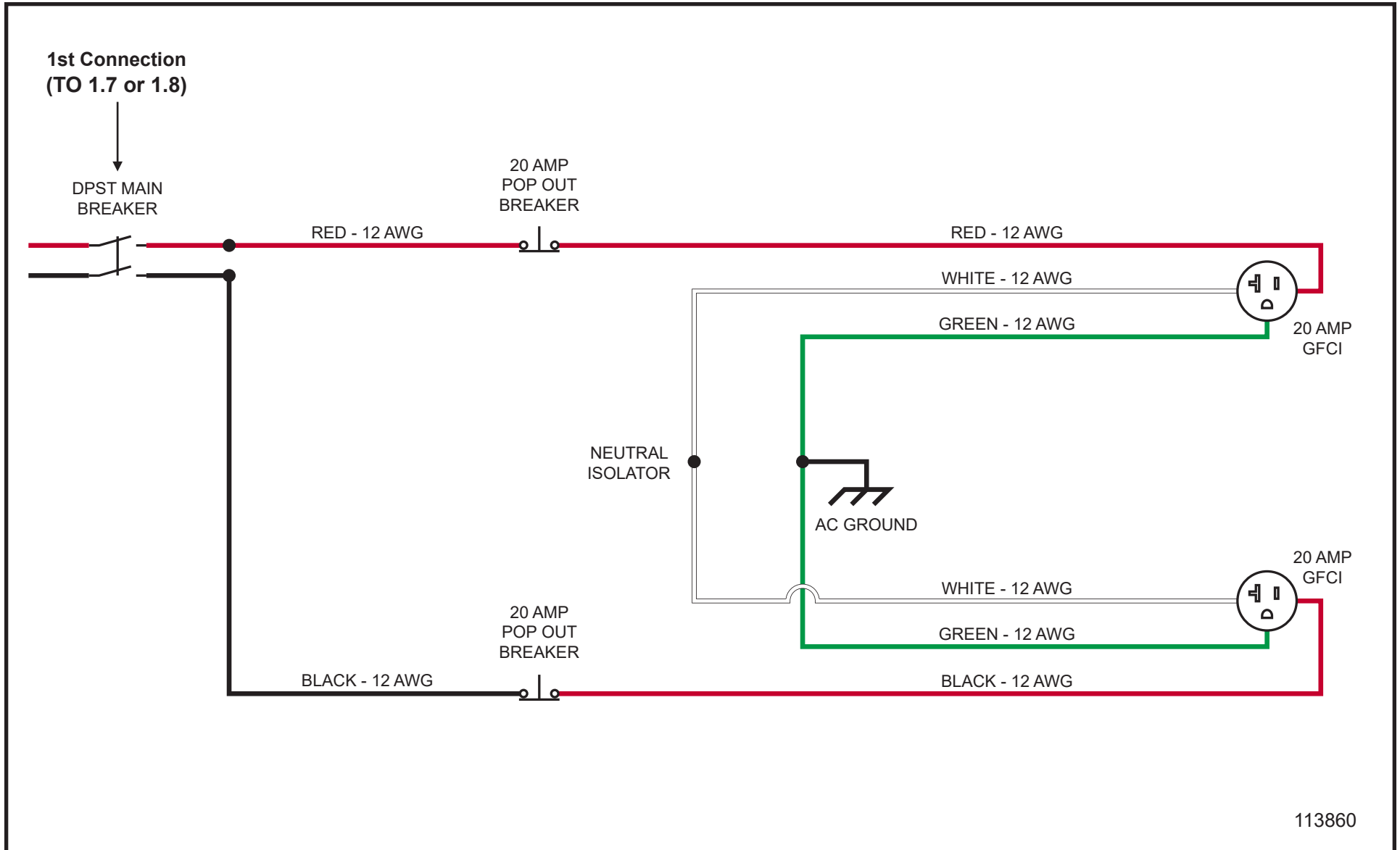

## 1.19 - 2-Schuko NLV Outlet Schematic

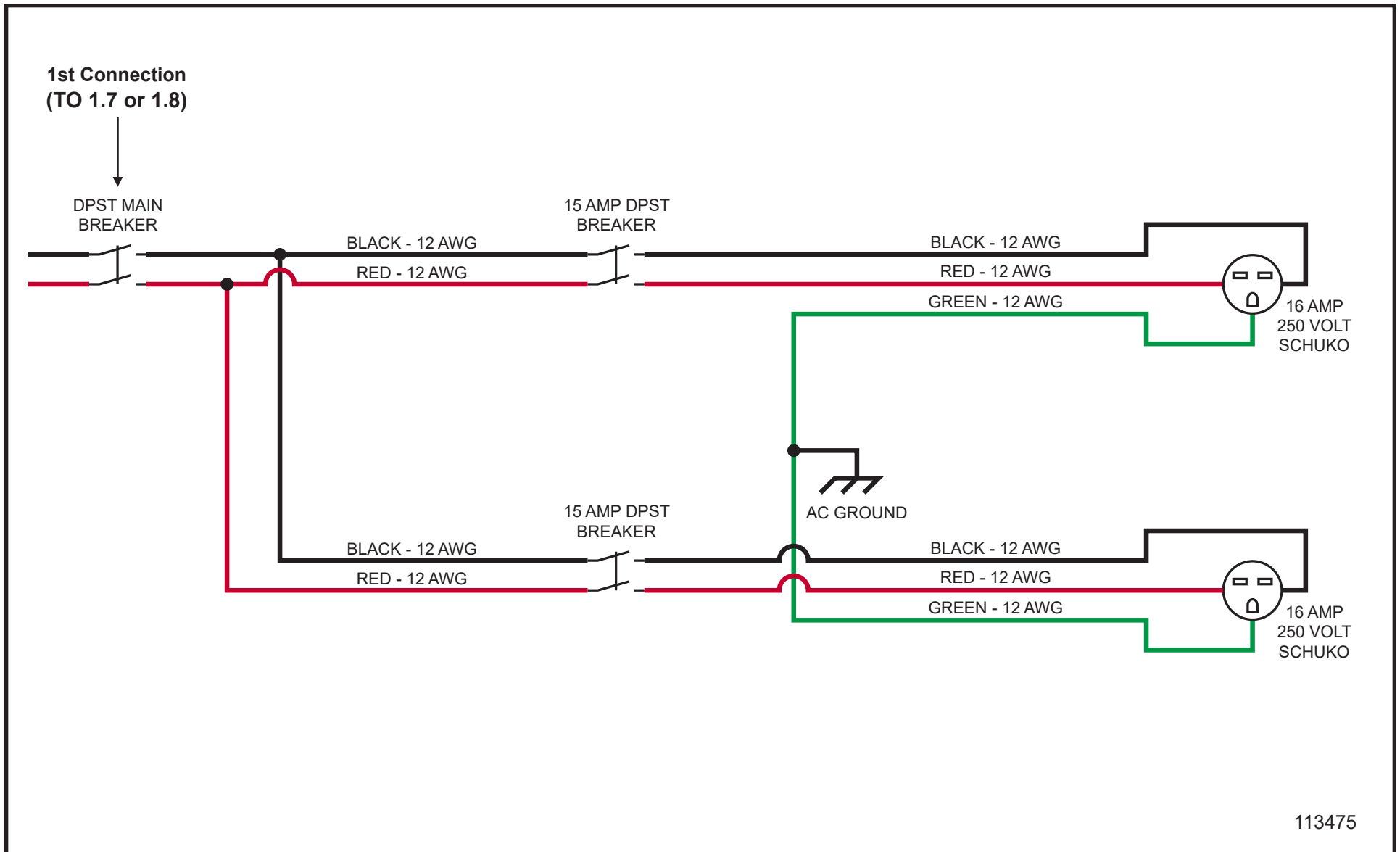

# Night-Lite V-Series

## 1.20 - Main Breaker to Light Switches Schematic

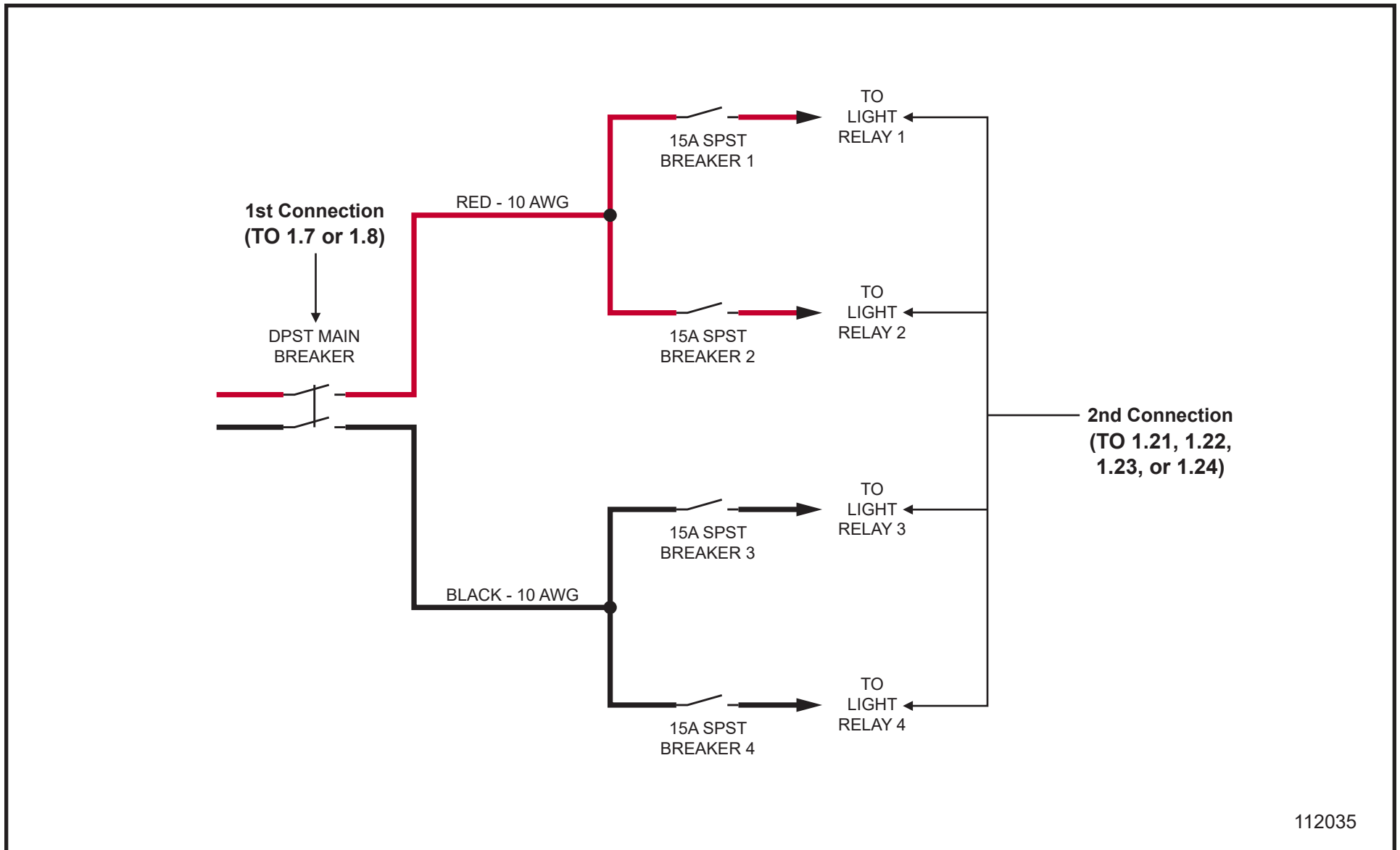

112035

## 1.21 - 4-Light 4-725 Relay NLV Schematic (Old Version)

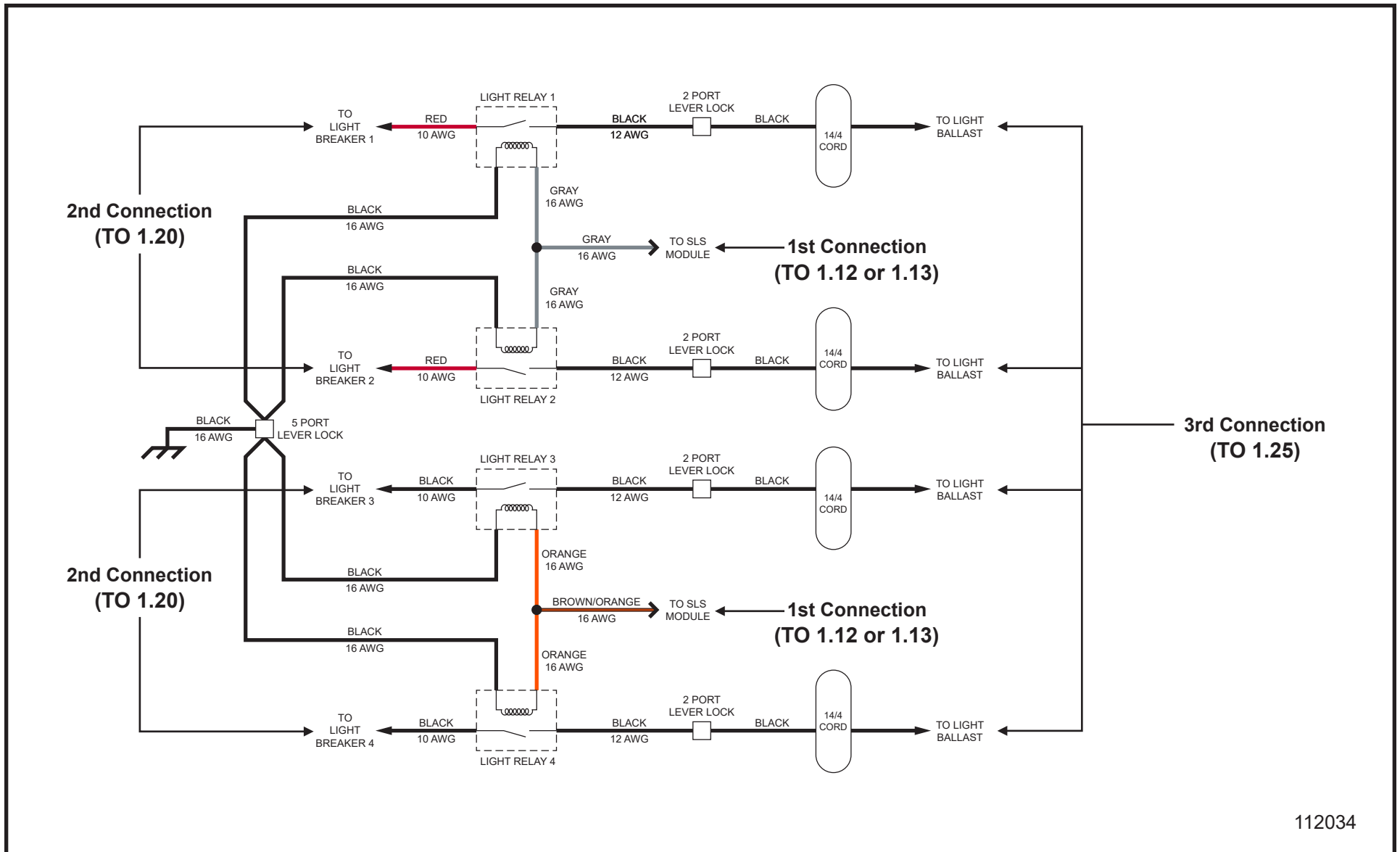

112034

# Night-Lite V-Series

## 1.22 - 4-Light 4-725 Relay NLV Schematic (New Version)

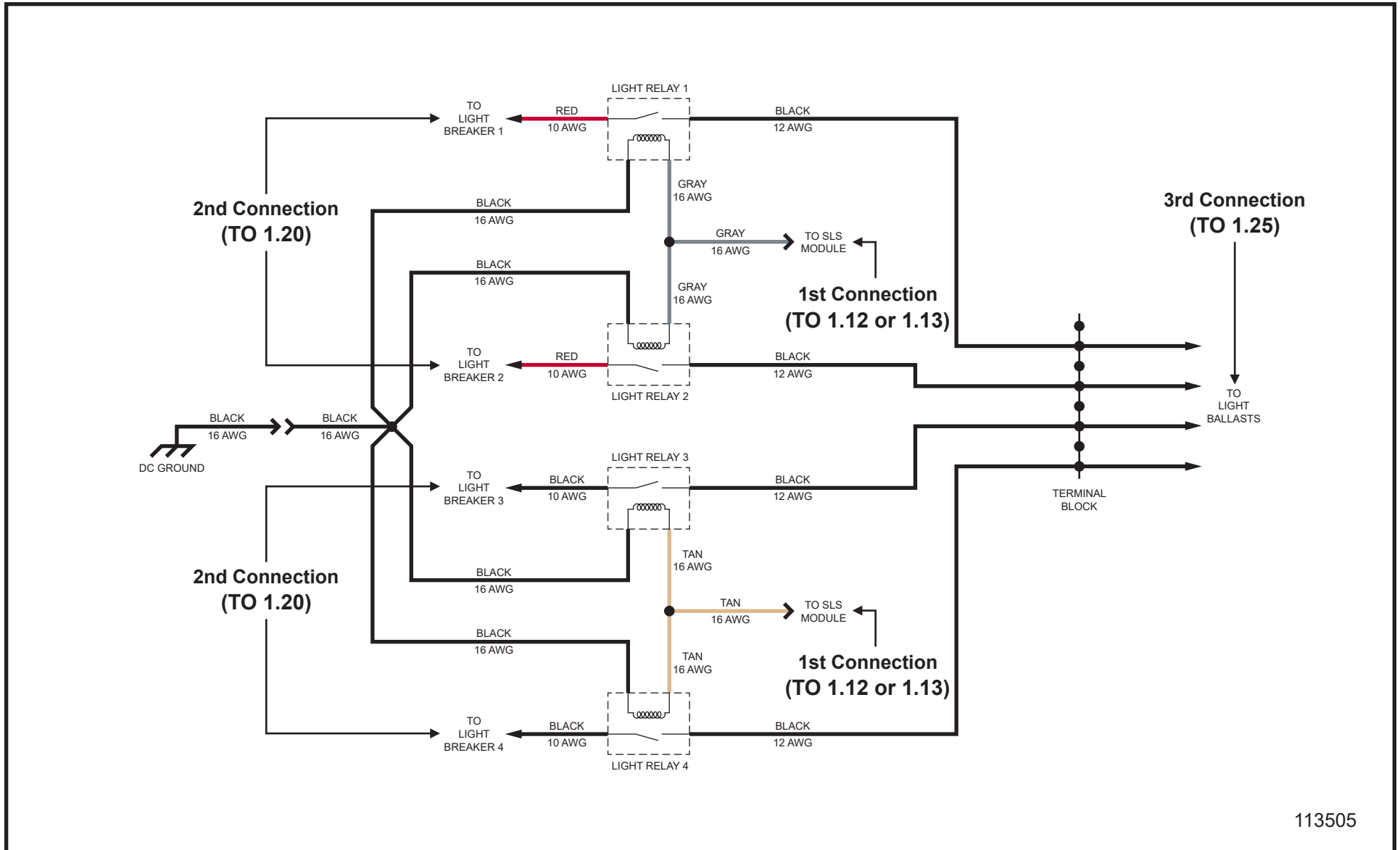

## 1.23 - 4-Light 4-Zettler Relay NLV Schematic

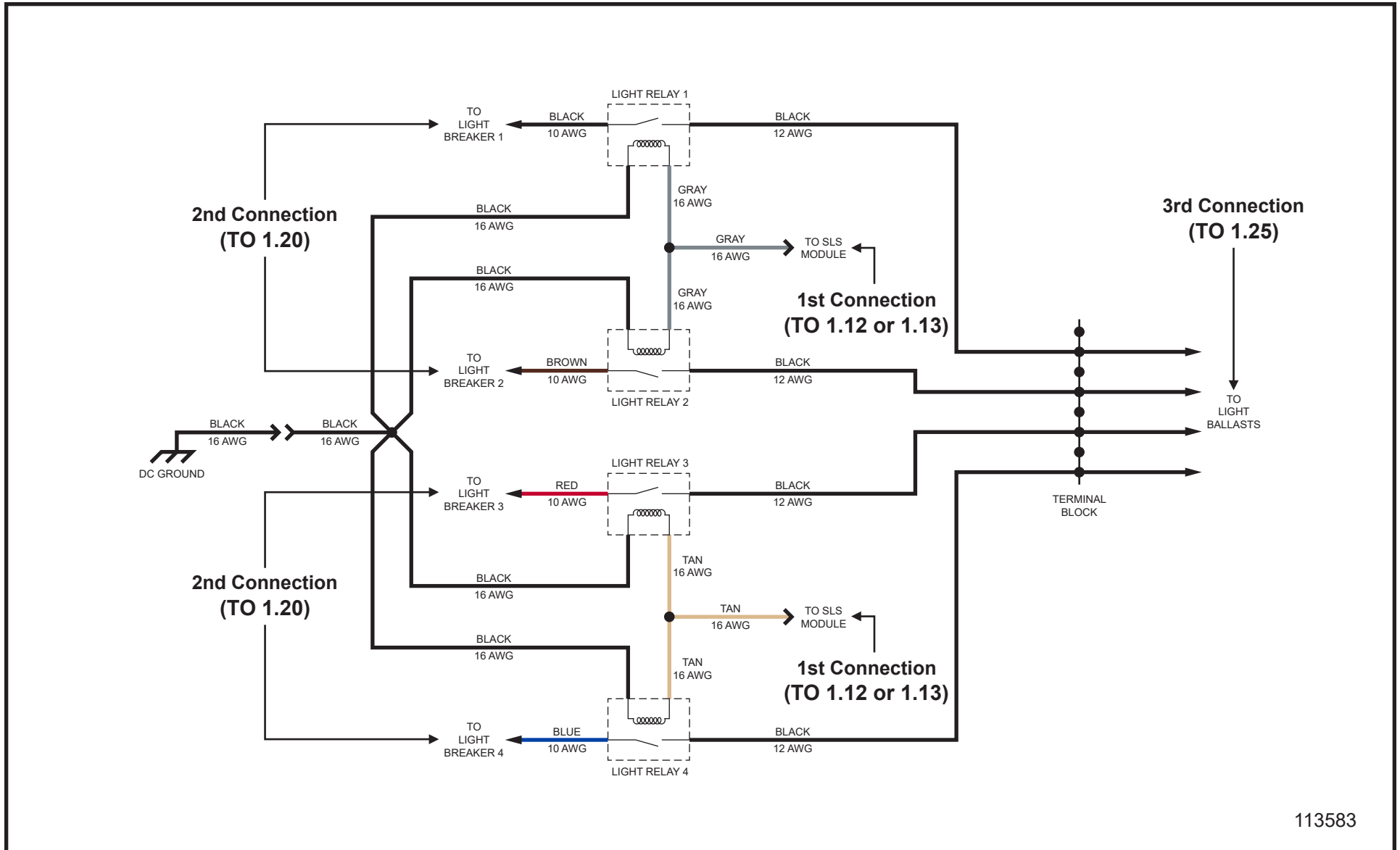

113583



## 1.25 - Ballast Cord NLV Schematic

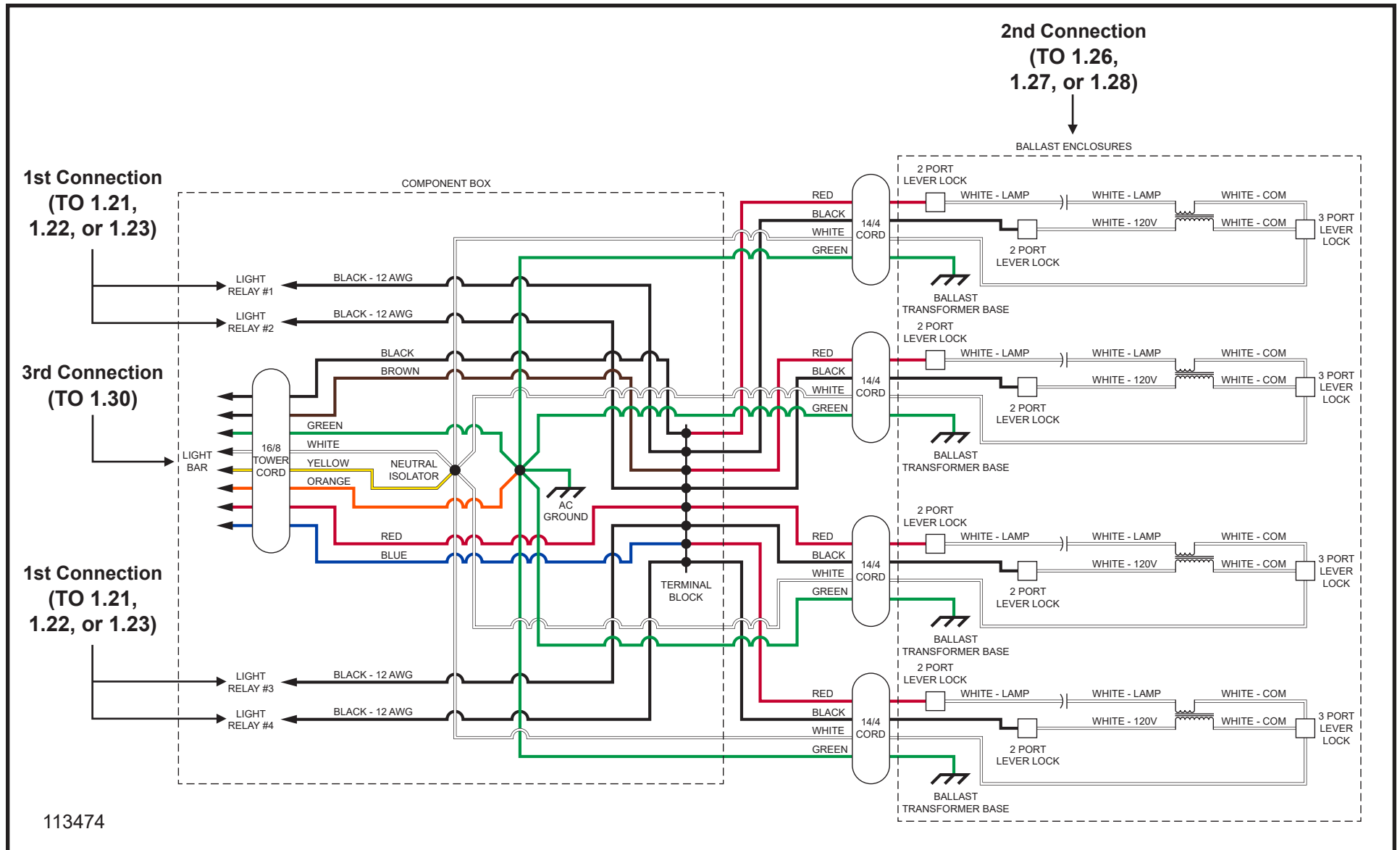

# Night-Lite V-Series

## 1.26 - 1000W 60Hz 120V Ballast Schematic

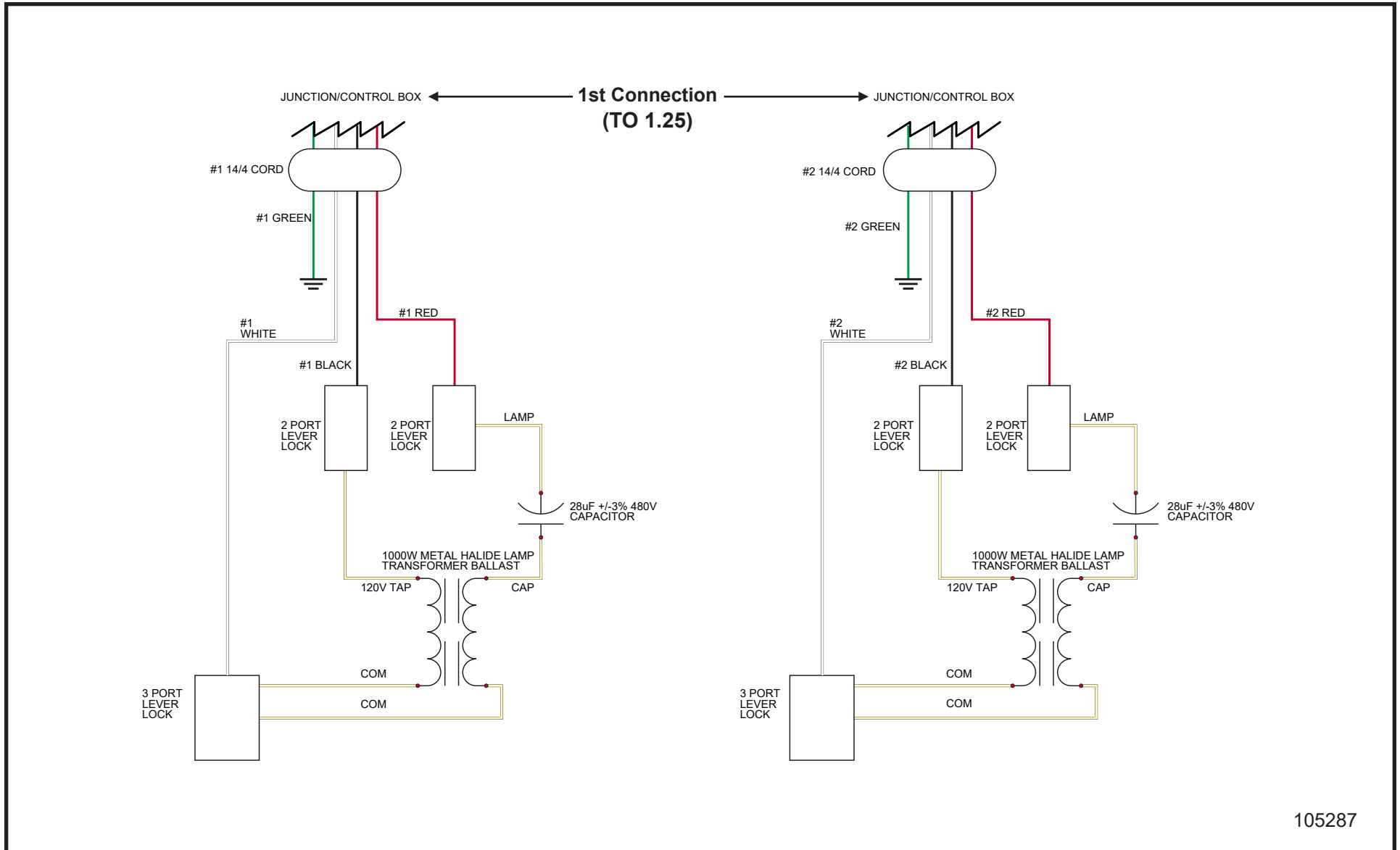

105287

## 1.27 - 1000W 50Hz 120V Ballast Schematic

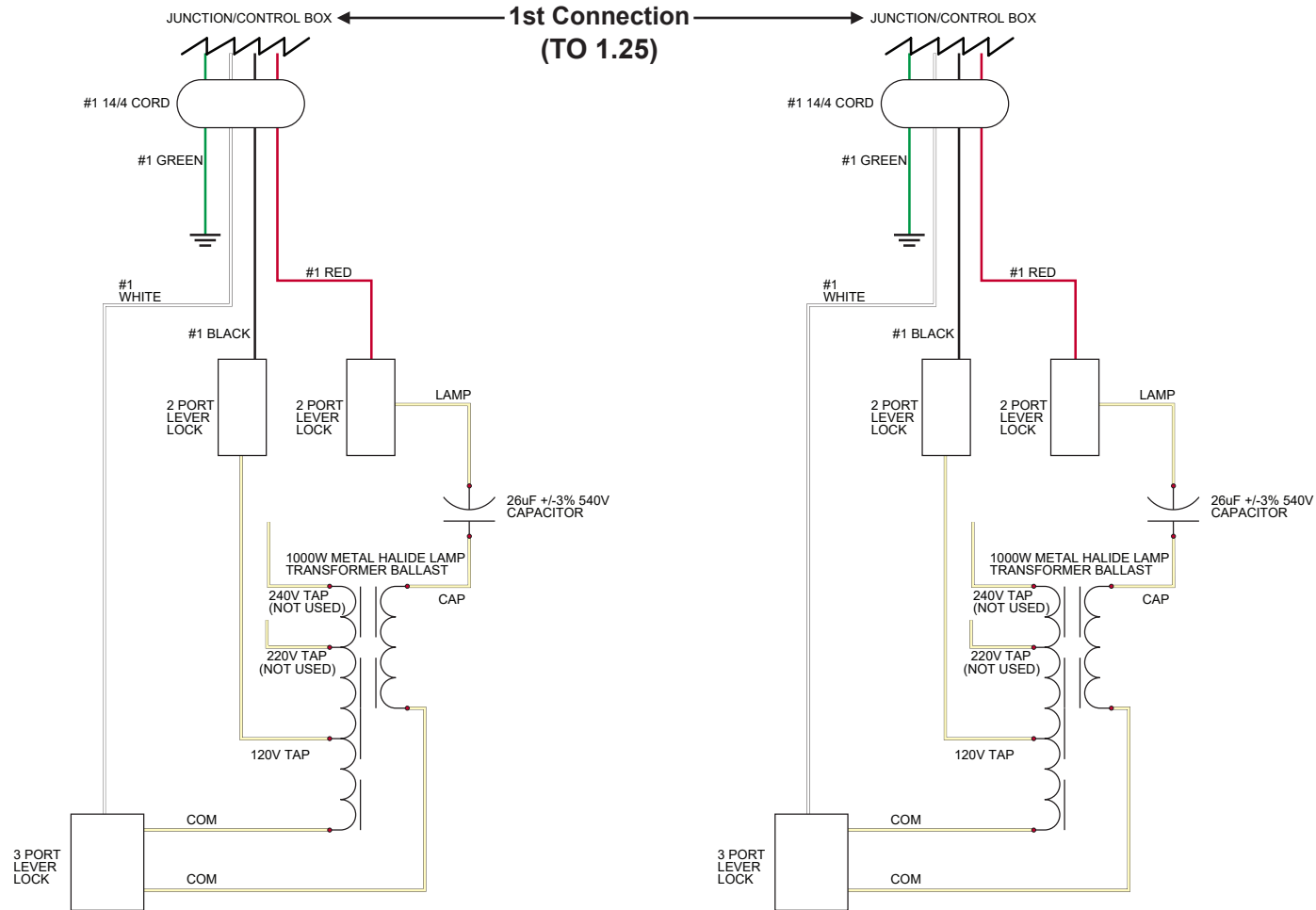

105288

# Night-Lite V-Series

## 1.28 - 1250W 60Hz 120V Ballast Schematic

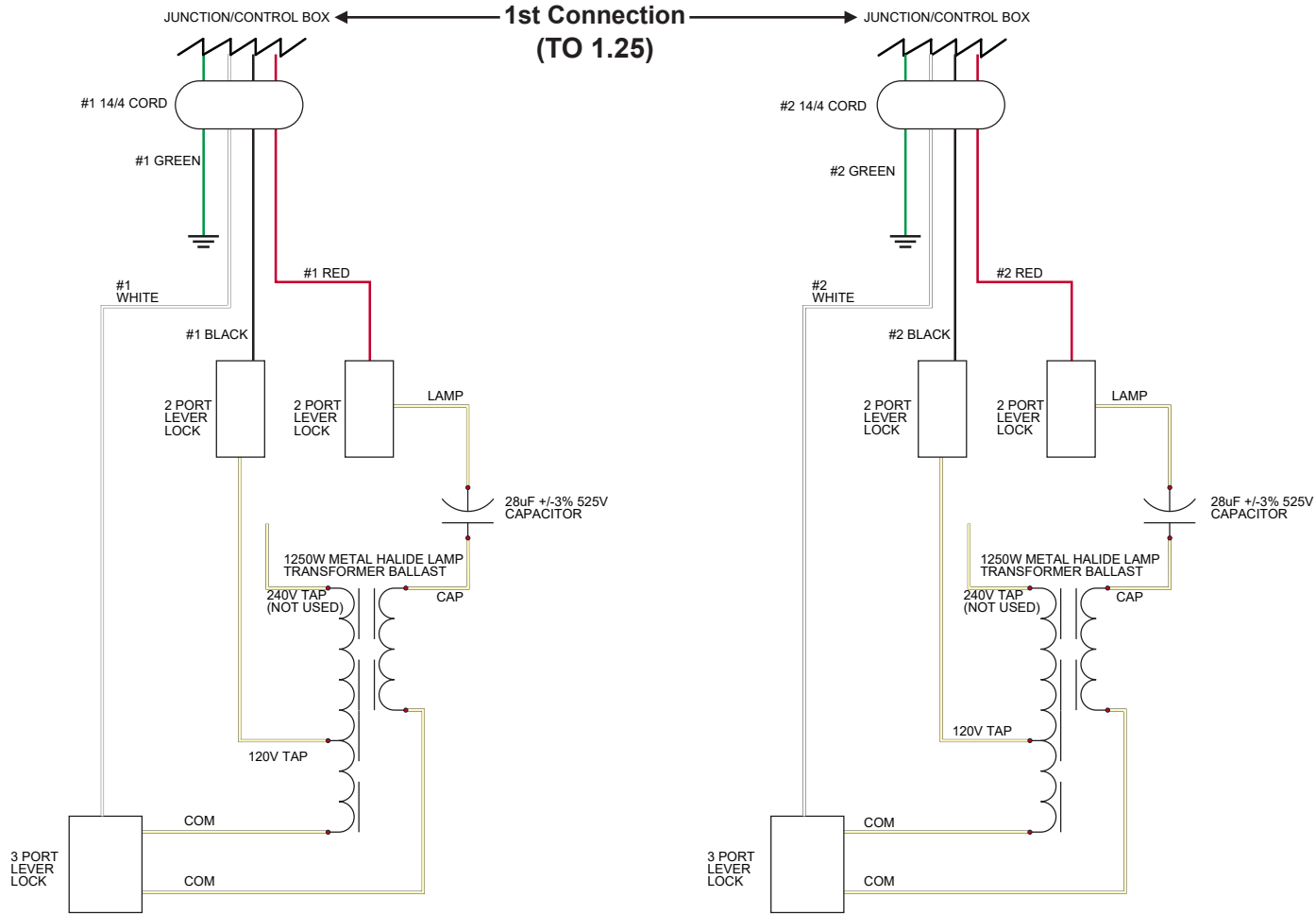

105286

## 1.29 - LED Drivers NLV Schematic

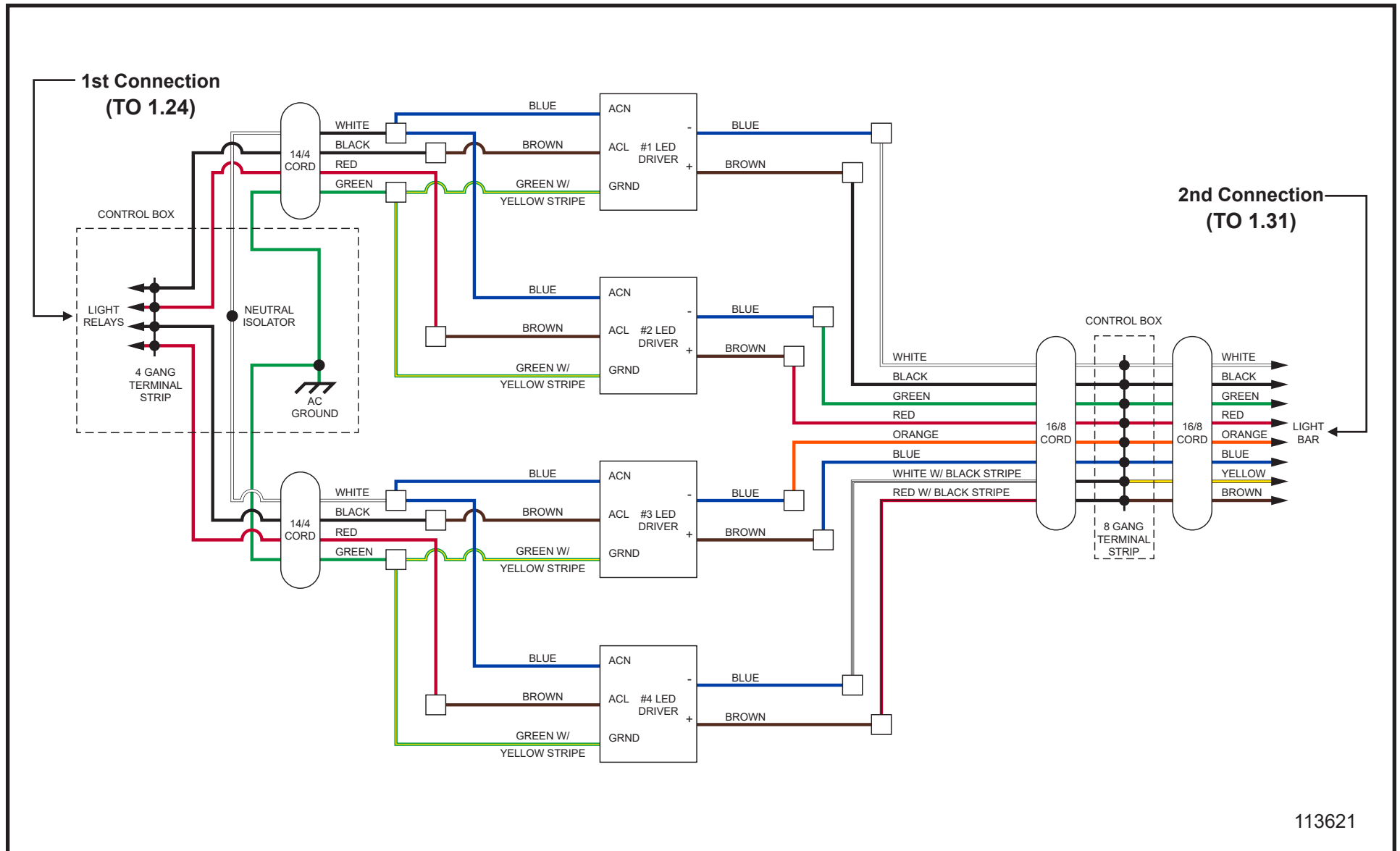

113621

# Night-Lite V-Series

## 1.30 - 4-Metal Halide Lamps Light Bar Schematic

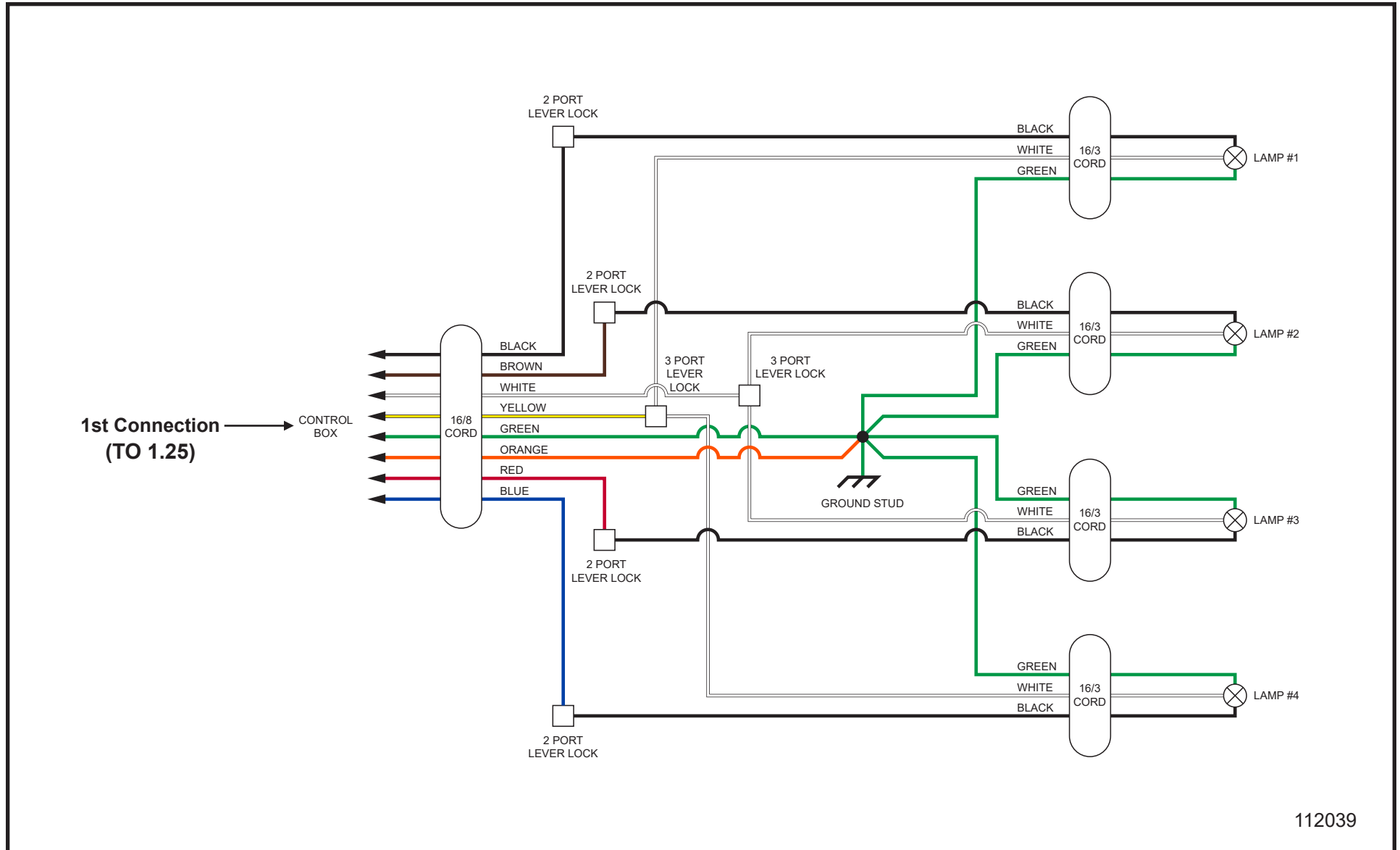

## 1.31 - 4-LED Lamps Light Bar Schematic

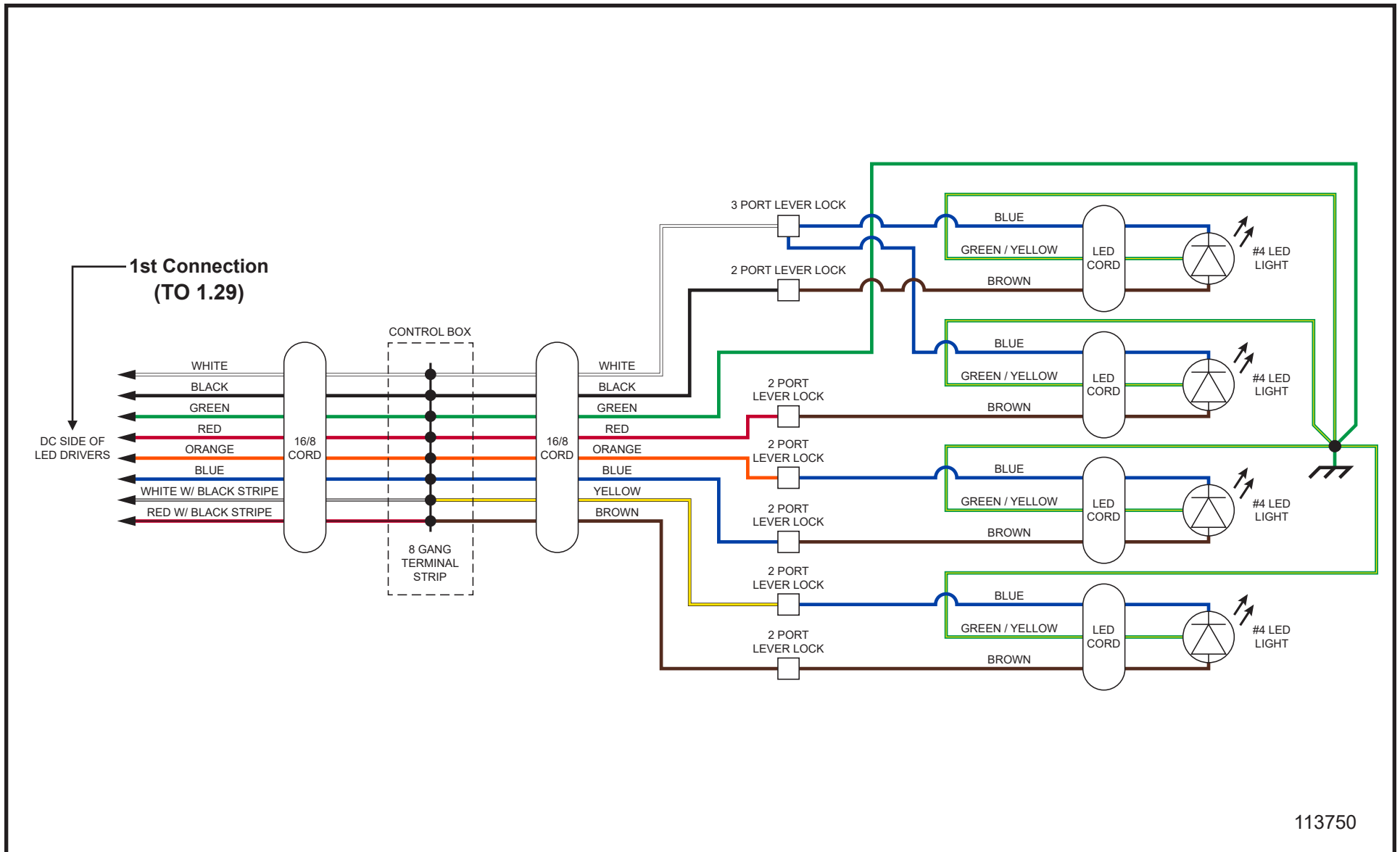

113750

# Night-Lite V-Series

## 1.32 - C1000 Electric Winch NLV Schematic (Old Version)

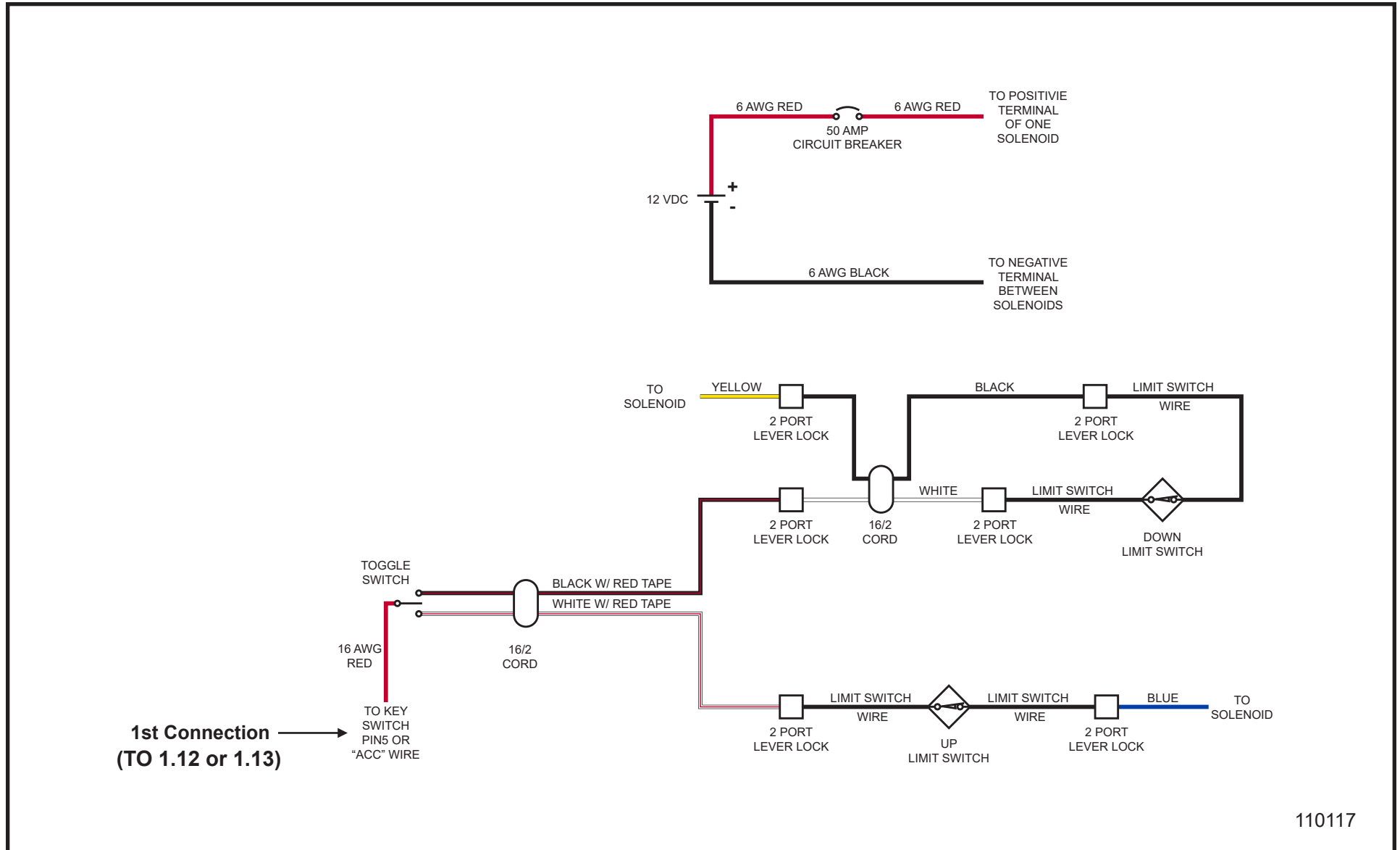

## 1.33 - C1000 Electric Winch NLV Schematic (New Version)

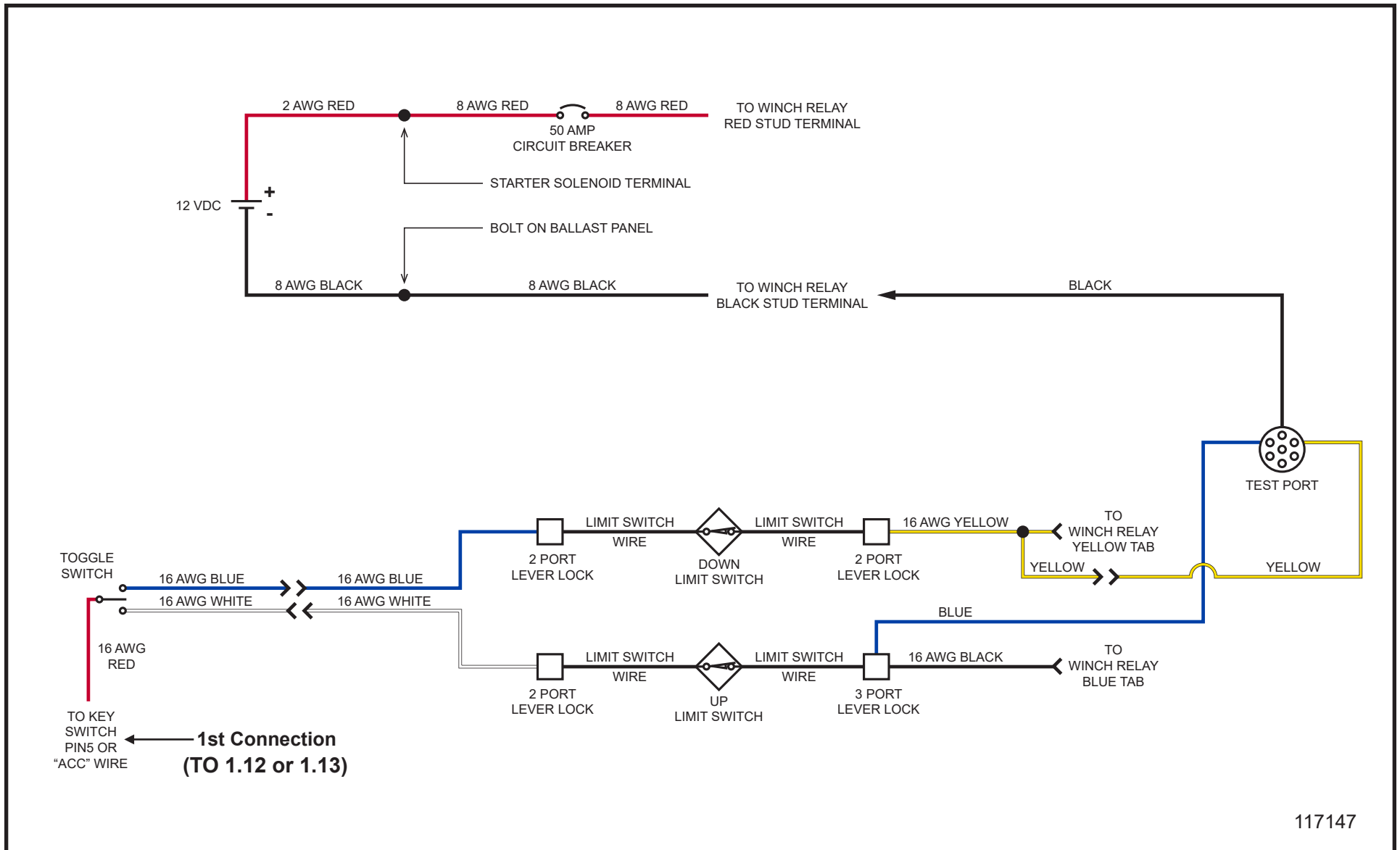

117147

# Night-Lite V-Series

## 1.34 - SH 1000 Electric Winch NLV Schematic

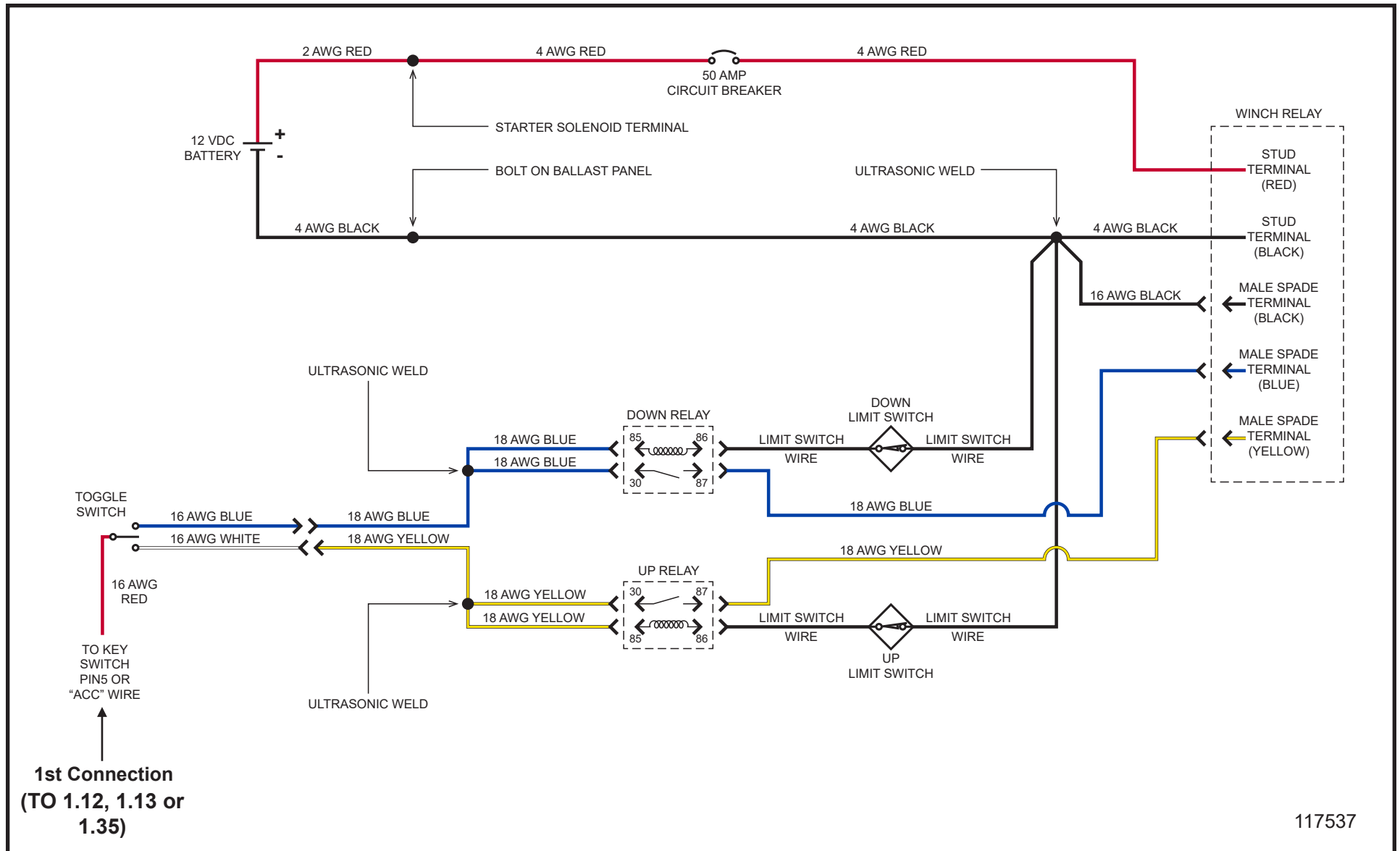



# Night-Lite V-Series

## 1.36 - Remote Start Deep Sea L401 Schematic

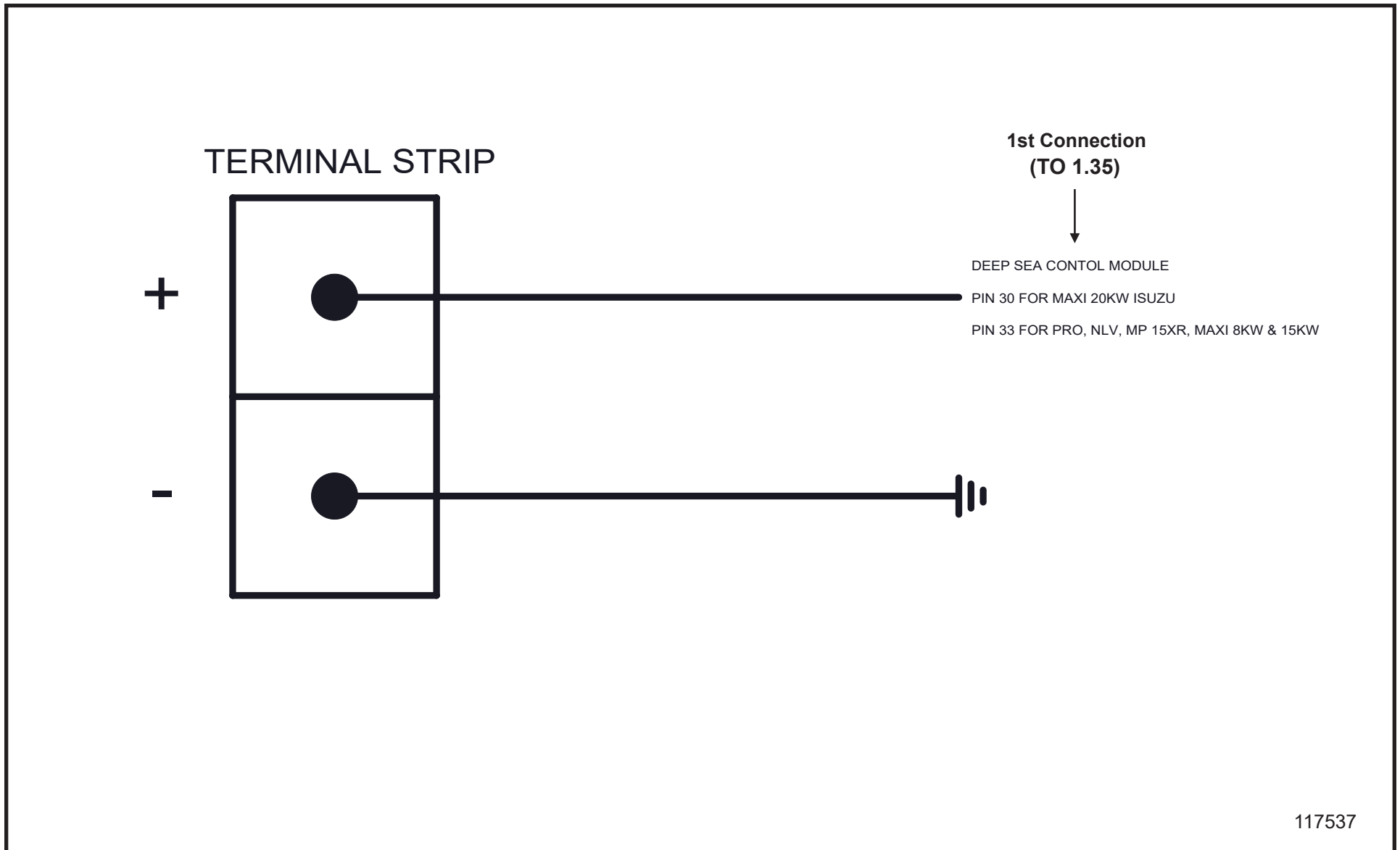

# Night-Lite V-Series



1502 West 4th Avenue  
Holdrege, NE 68949

phone: (308) 995-4495 • toll free: (800) 562-1373  
fax: (308) 995-5887

[www.allmand.com](http://www.allmand.com)