



(en) Schematic Manual
MAXI-HEAT® 1MBTU

TABLE OF CONTENTS

| | |
|--|--------|
| Deep Sea Control Panel Harness with Emergency Stop Schematic (124324 & 119747) | (1.1) |
| CAT C1.1 Engine Harness Schematic (110112) | (1.2) |
| Kubota D1105 Engine Harness Schematic (112776) | (1.3) |
| Kubota D1005 Engine Harness Schematic (108044) | (1.4) |
| PacBrake Emergency Engine Air Shutoff Valve Schematic (117814) | (1.5) |
| 6/4 8kW Linz Generator Cord Schematic (126075) | (1.6) |
| AC Distribution Blocks to Front and Back Heaters Schematic (119750) | (1.7) |
| Three Fuel Gauges Schematic (119738) | (1.8) |
| One Fuel Gauge Schematic (119736) | (1.9) |
| Three Fuel Tank Two Door Switch Schematic (119741) | (1.10) |
| One Fuel Tank Two Door Switch Schematic (119744) | (1.11) |
| DC Distribution Blocks 2 Heated Fuel Water Separators Schematic (119739) | (1.12) |
| Heater Control Cord Two Heater Schematic (119746) | (1.13) |
| Tail Light Harness Schematic (119751) | (1.14) |
| Trailer Break Away Wire Harness Schematic (119752) | (1.15) |
| 15A 120V GFCI Outlet Schematic (126395) | (1.16) |
| 15A 120V GFCI Outlet with Female GFCI Plug Schematic (126547) | (1.17) |
| Trailer Curt Break Away Wire Harness Schematic (126665) | (1.18) |

MAXI-HEAT® 1MBTU

1.1 - Deep Sea Control Panel Harness with Emergency Stop Schematic

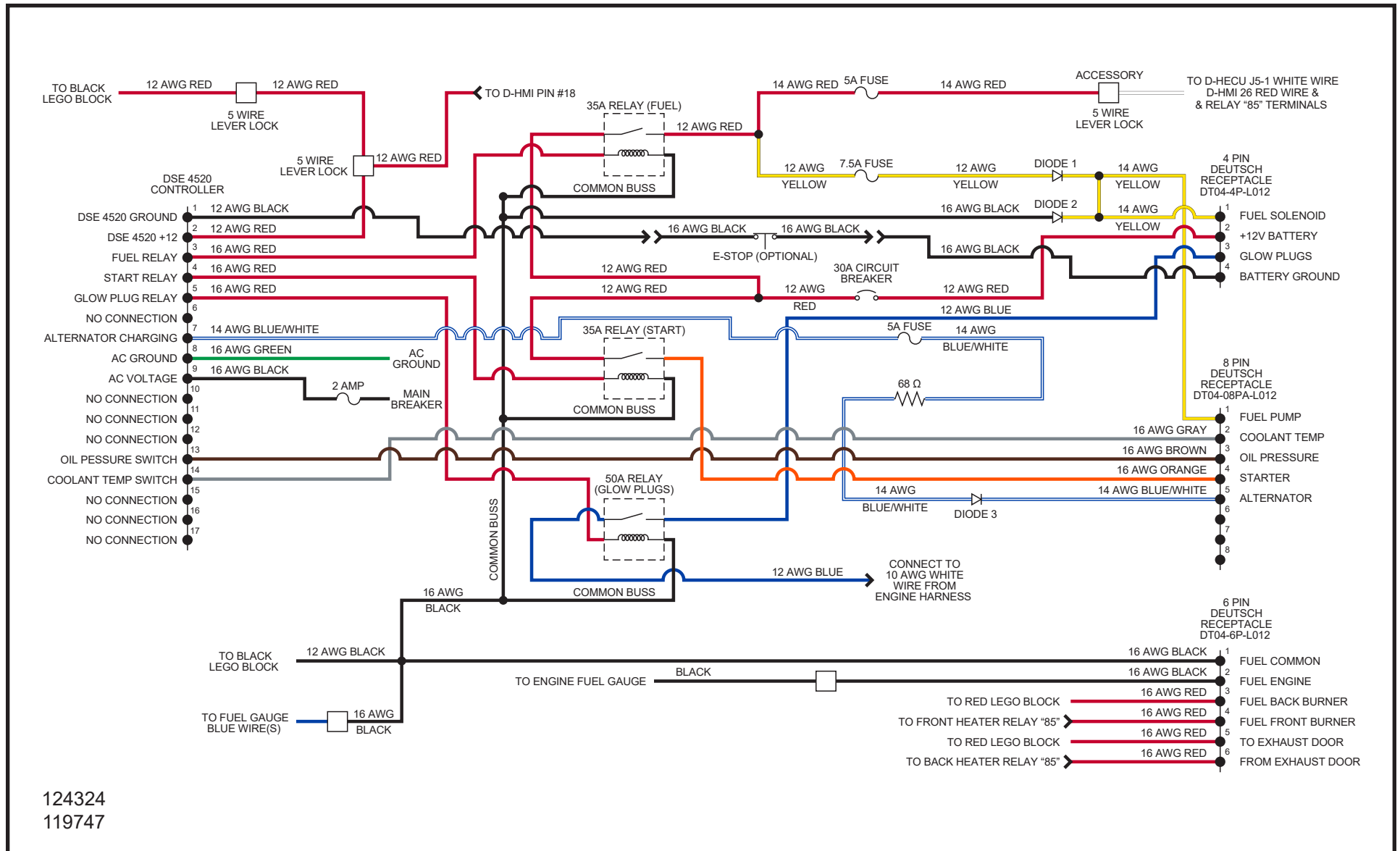

124324
119747

MAXI-HEAT® 1MBTU

1.2 - CAT C1.1 Engine Harness Schematic

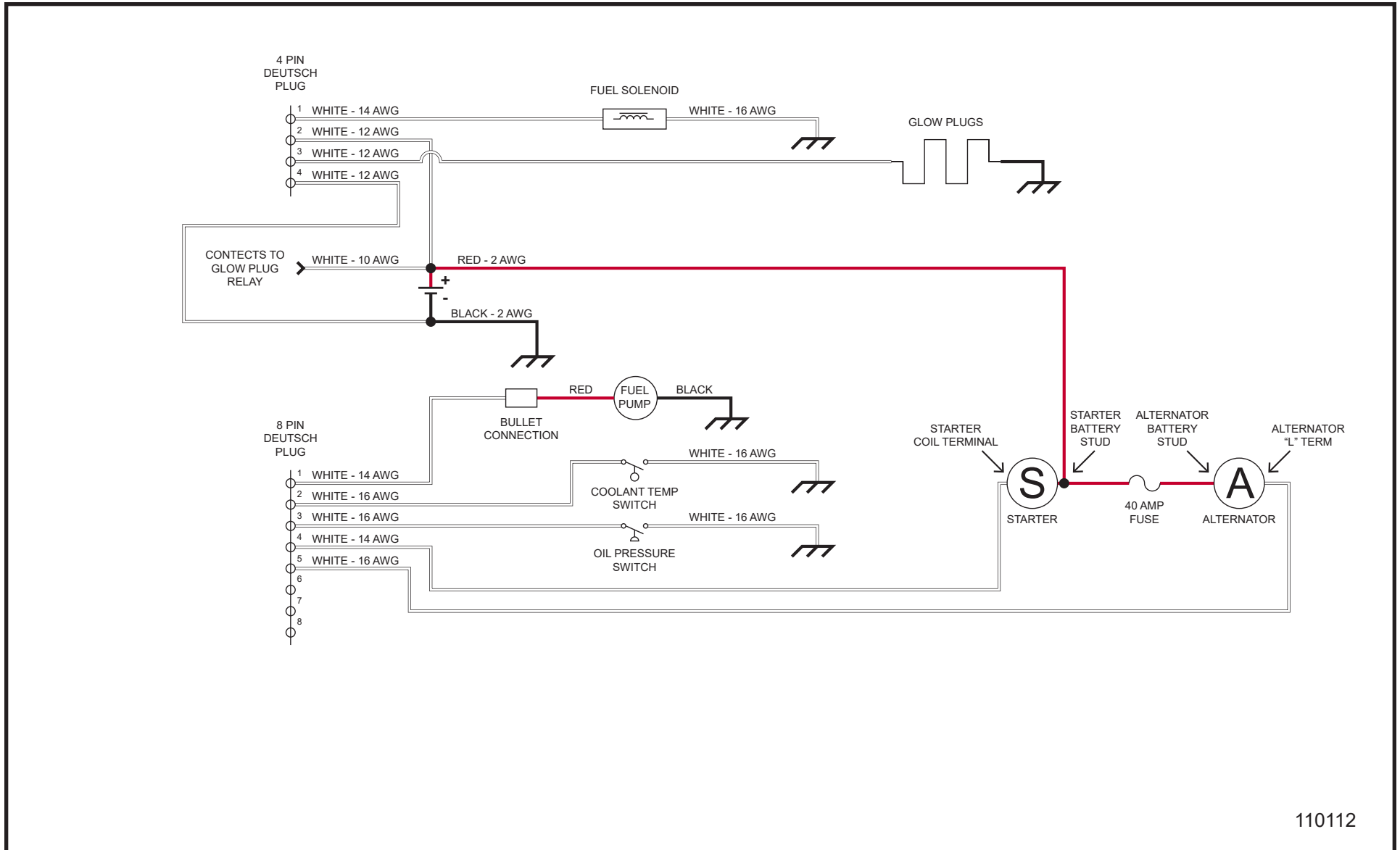

110112

1.3 - Kubota D1105 Engine Harness Schematic

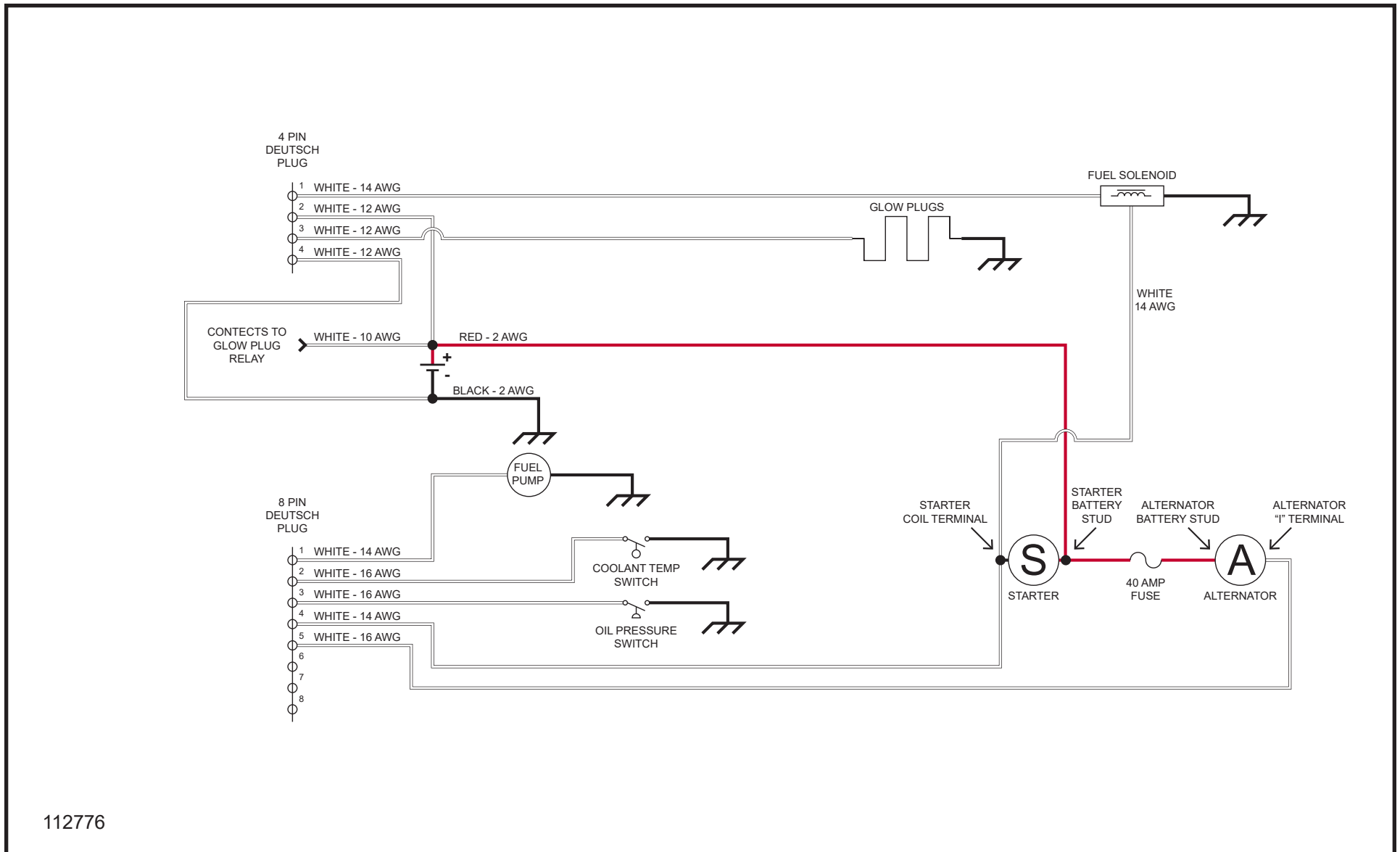

112776

MAXI-HEAT® 1MBTU

1.4 - Kubota D1005 Engine Harness Schematic

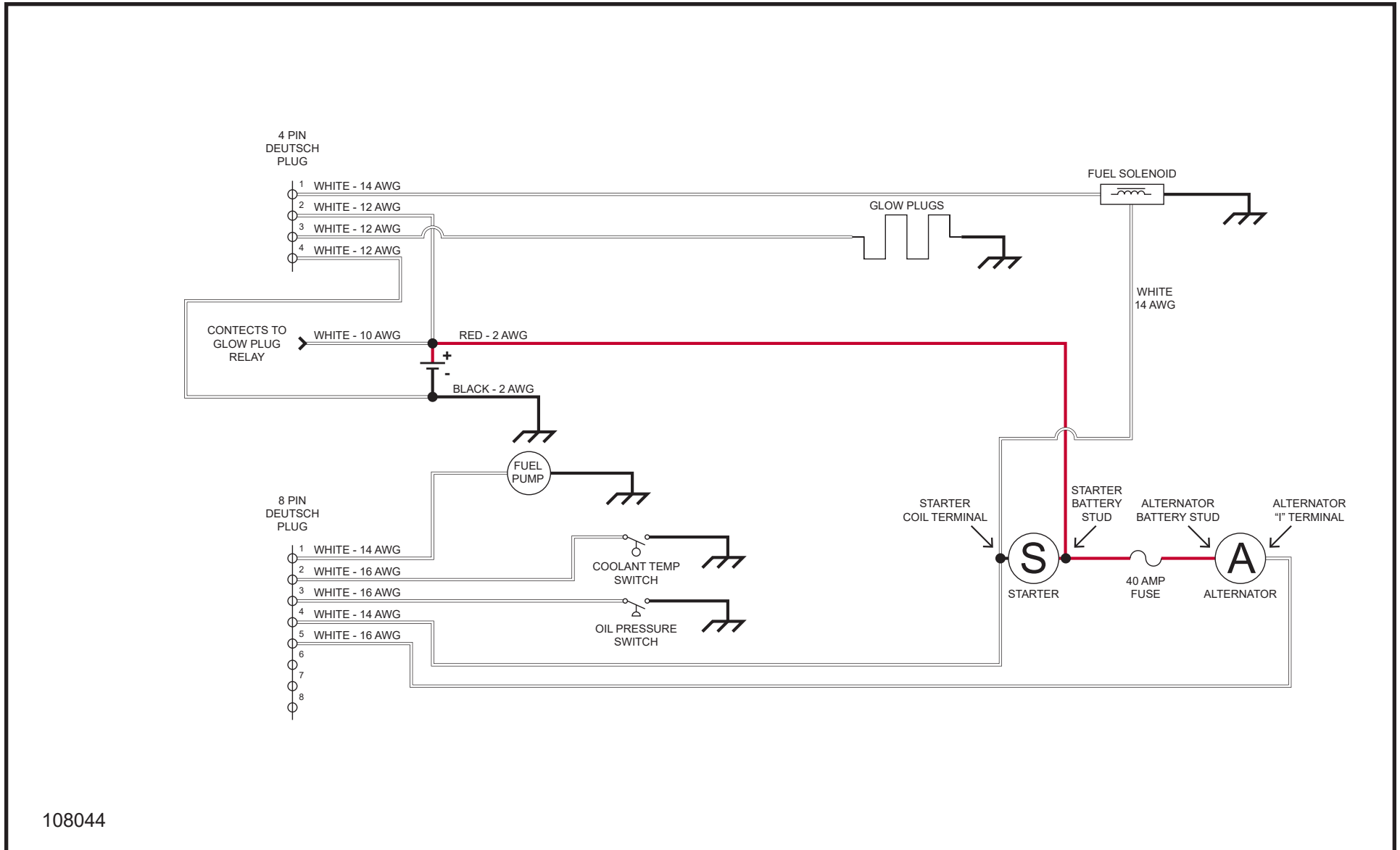

1.5 - PacBrake Emergency Engine Air Shutoff Valve Schematic

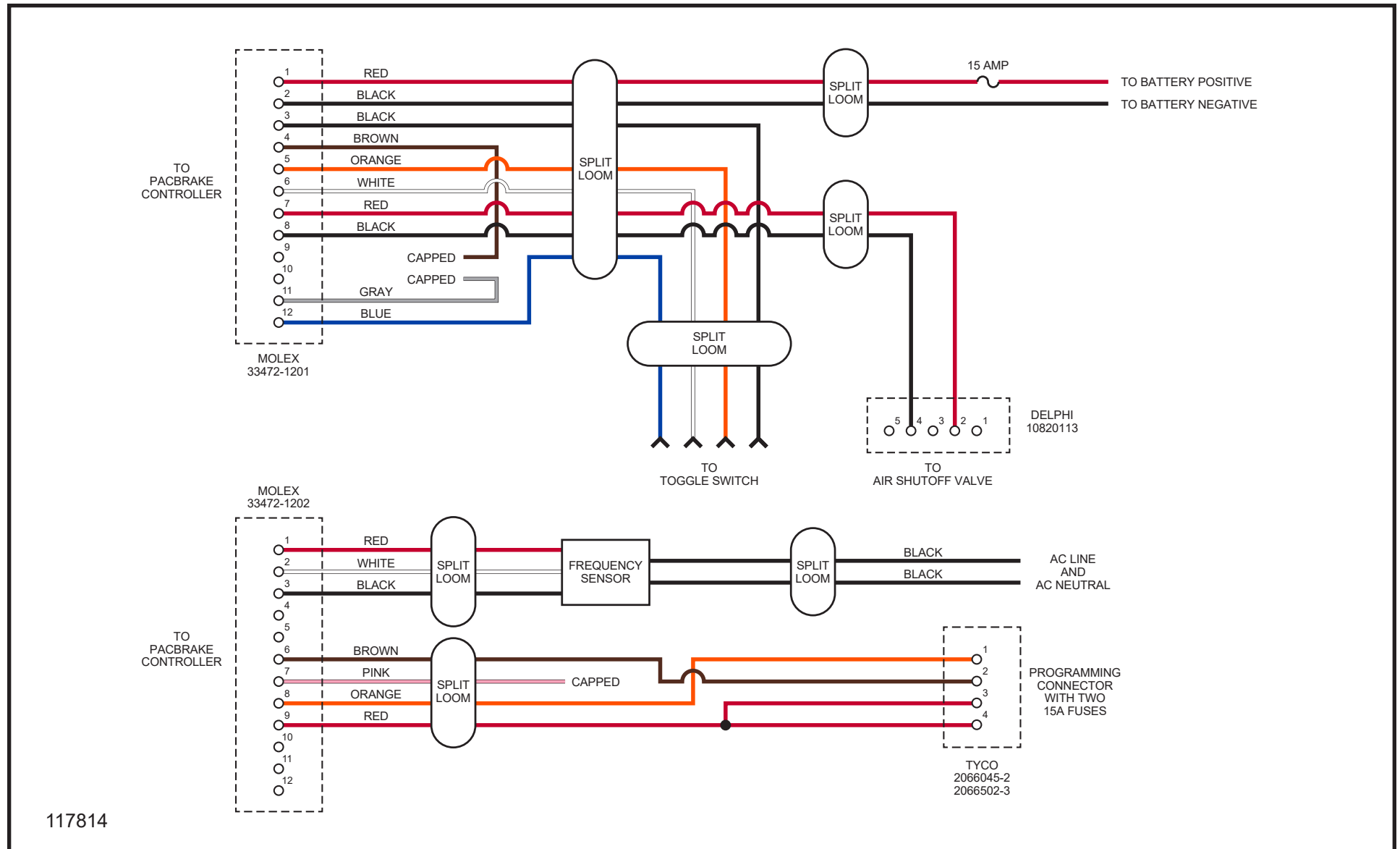

MAXI-HEAT® 1MBTU

1.6 - 6/4 8kW Linz Generator Cord Schematic

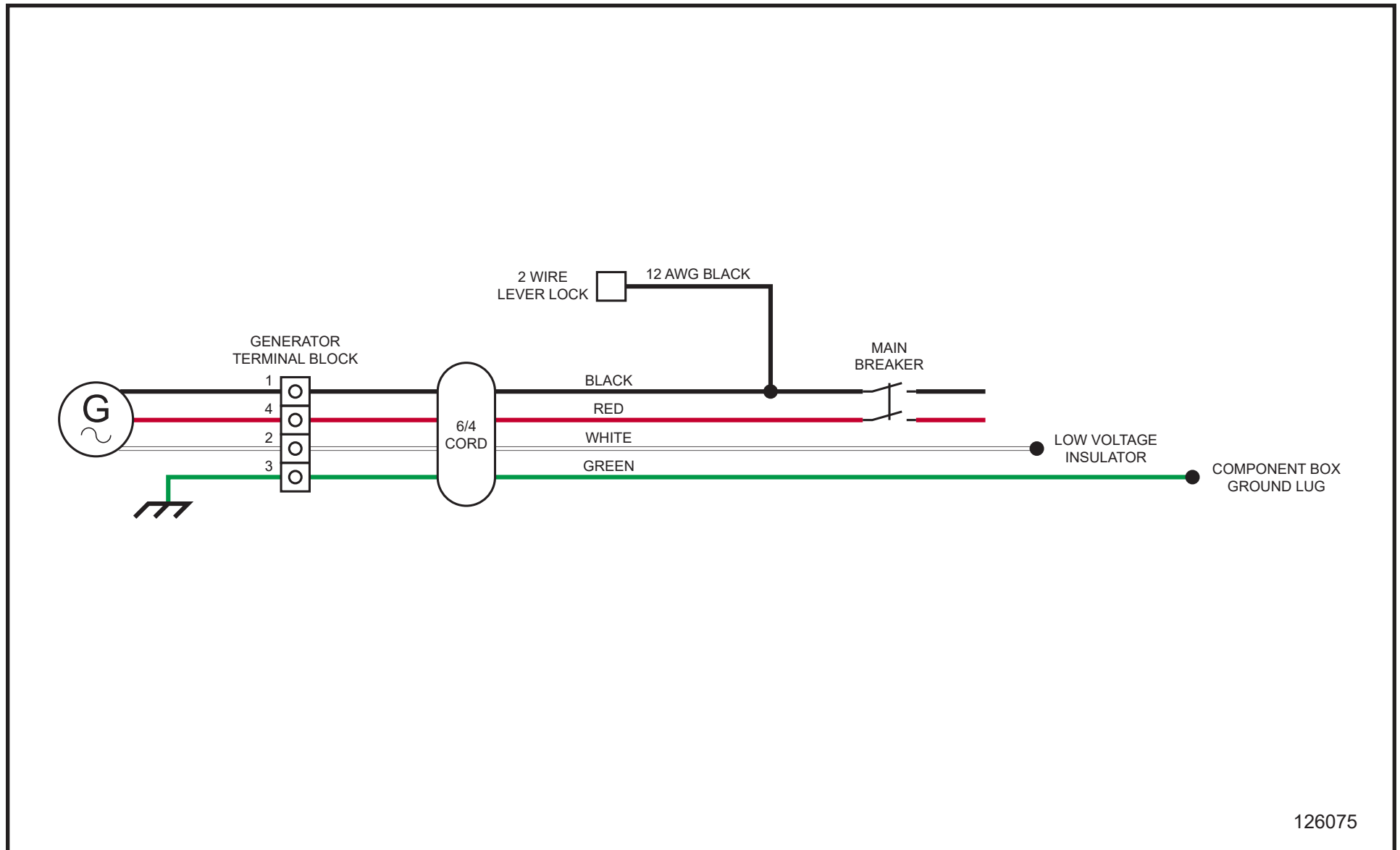

1.7 - AC Distribution Blocks to Front and Back Heaters Schematic

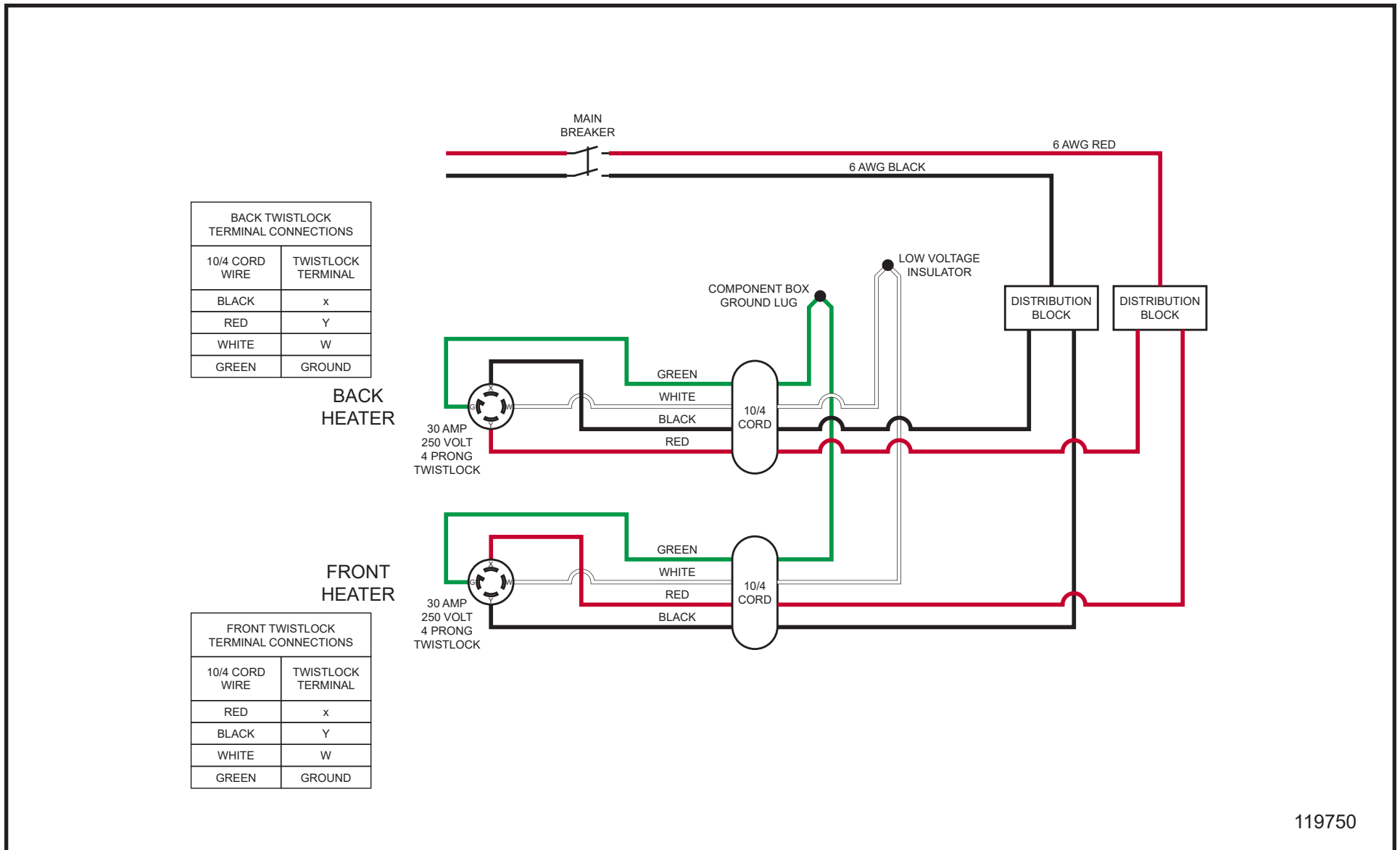

119750

MAXI-HEAT® 1MBTU

1.8 - Three Fuel Gauges Schematic

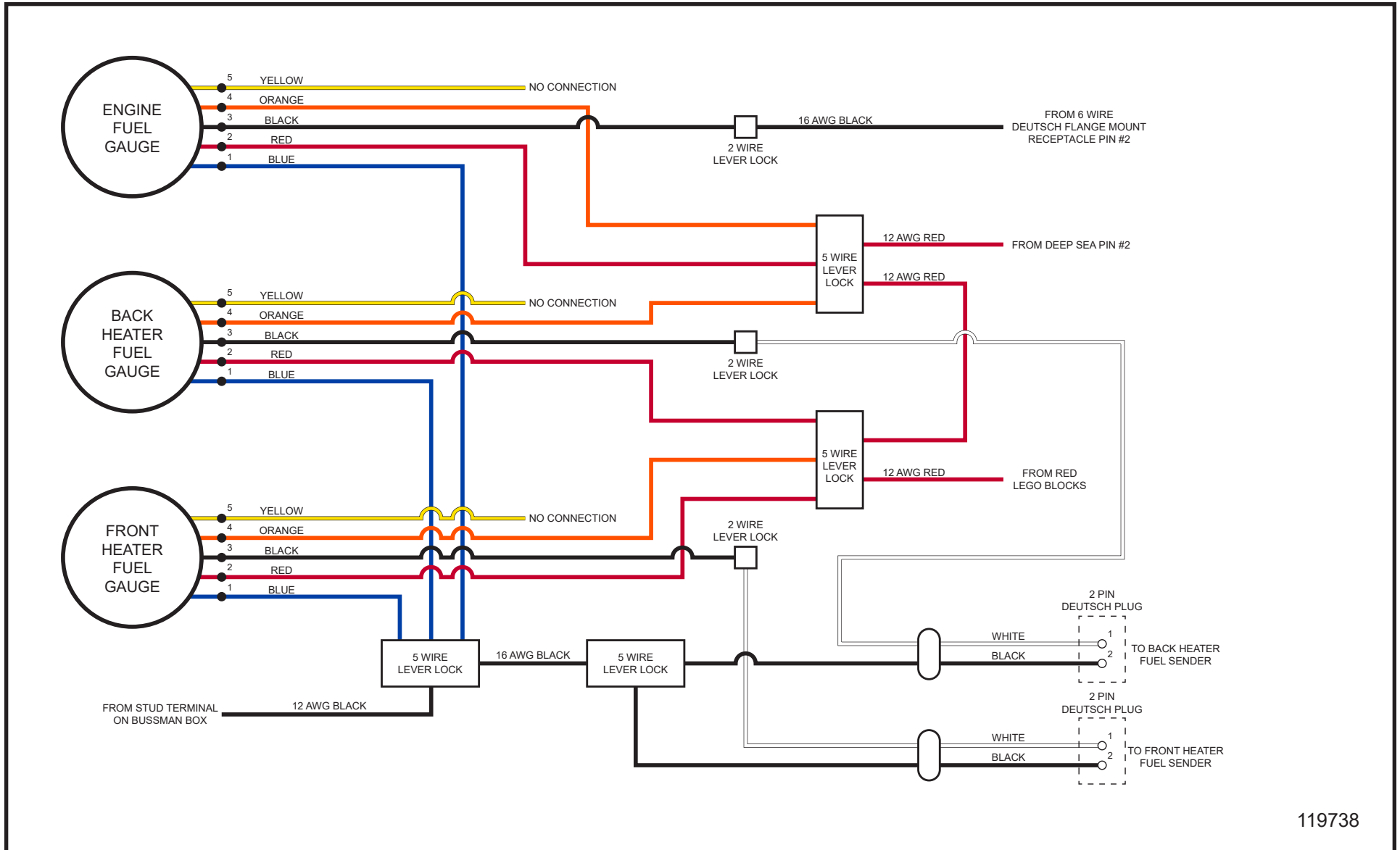

119738

1.9 - One Fuel Gauge Schematic

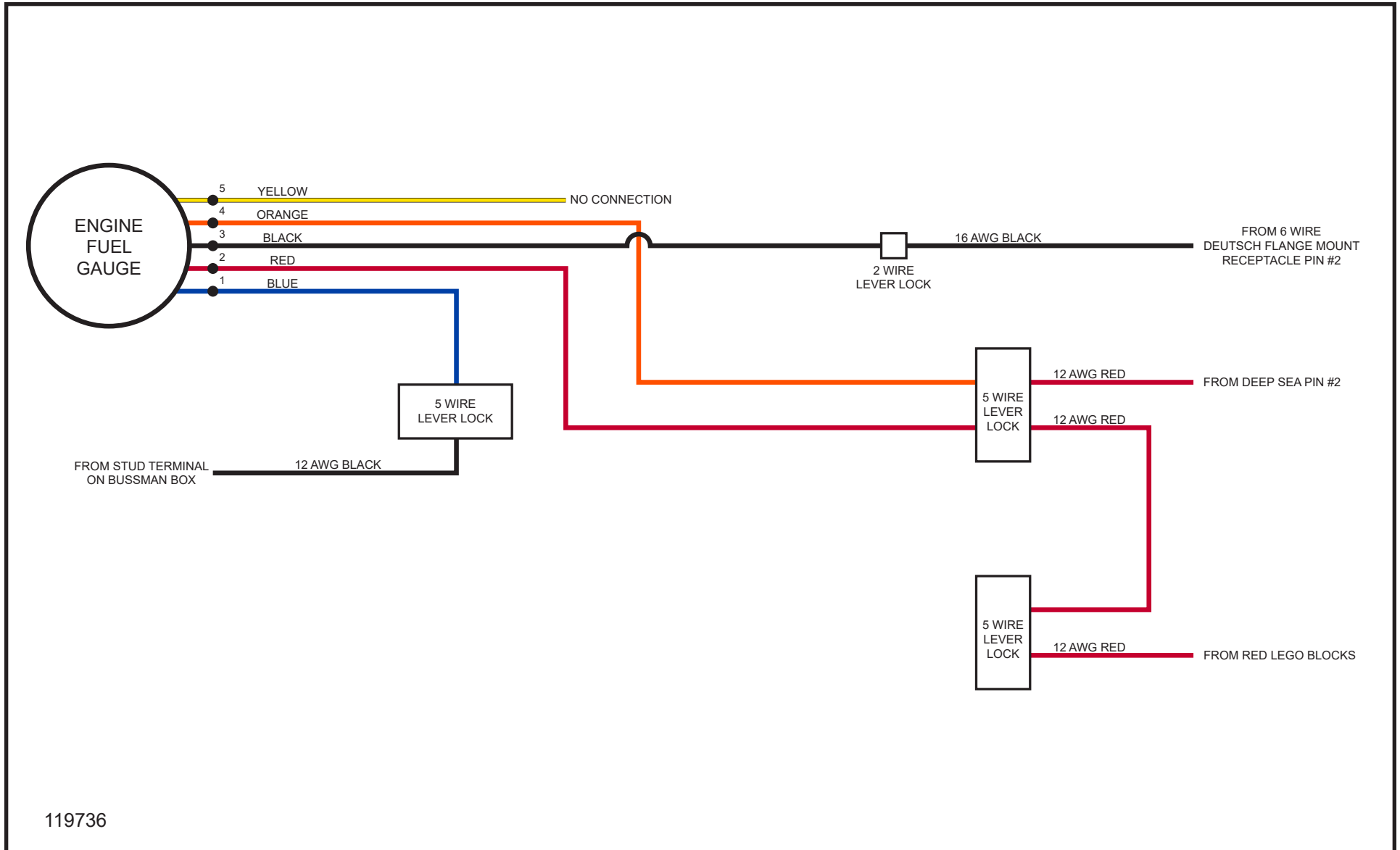

119736

MAXI-HEAT® 1MBTU

1.10 - Three Fuel Tank Two Door Switch Schematic

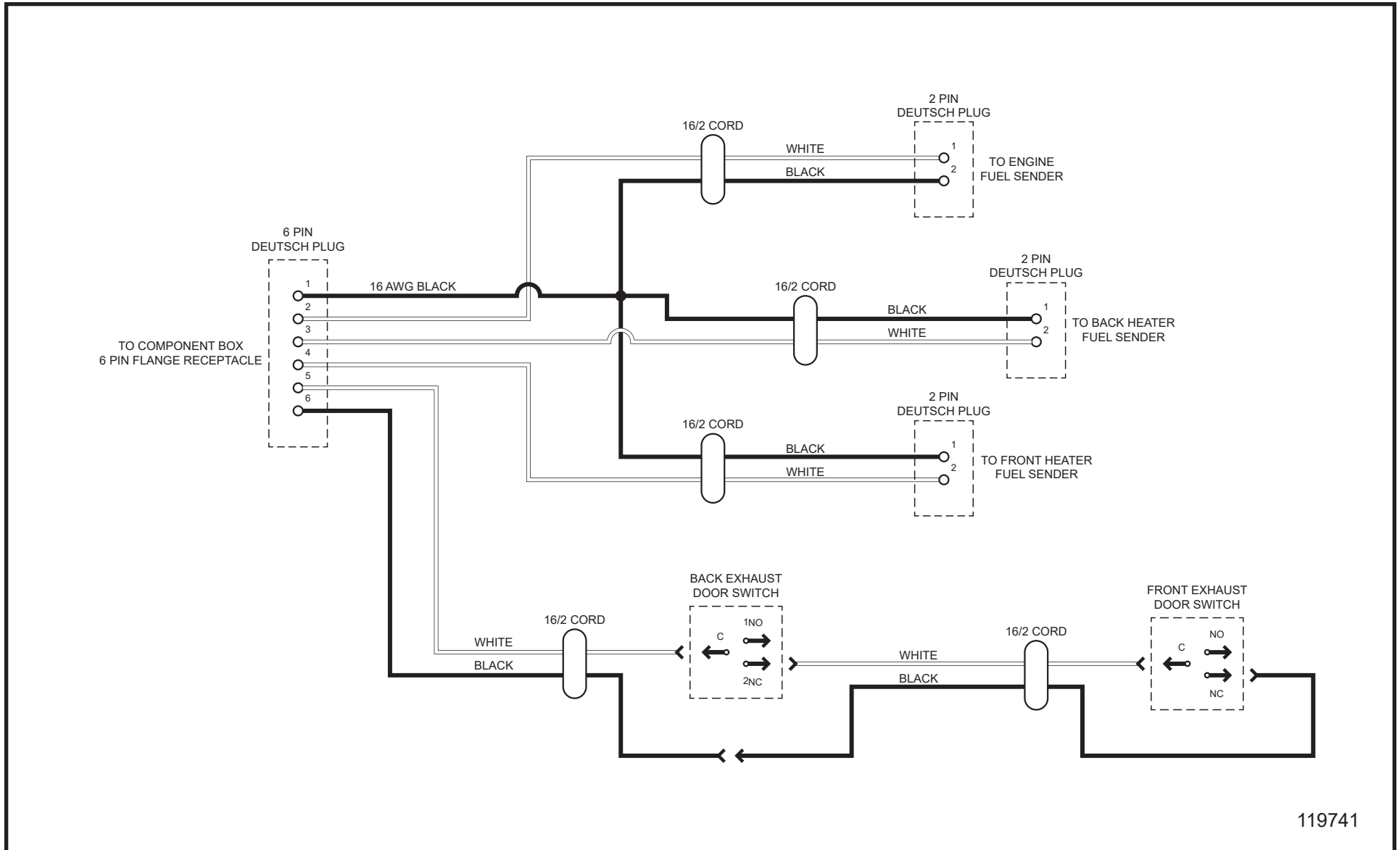

119741

1.11 - One Fuel Tank Two Door Switch Schematic

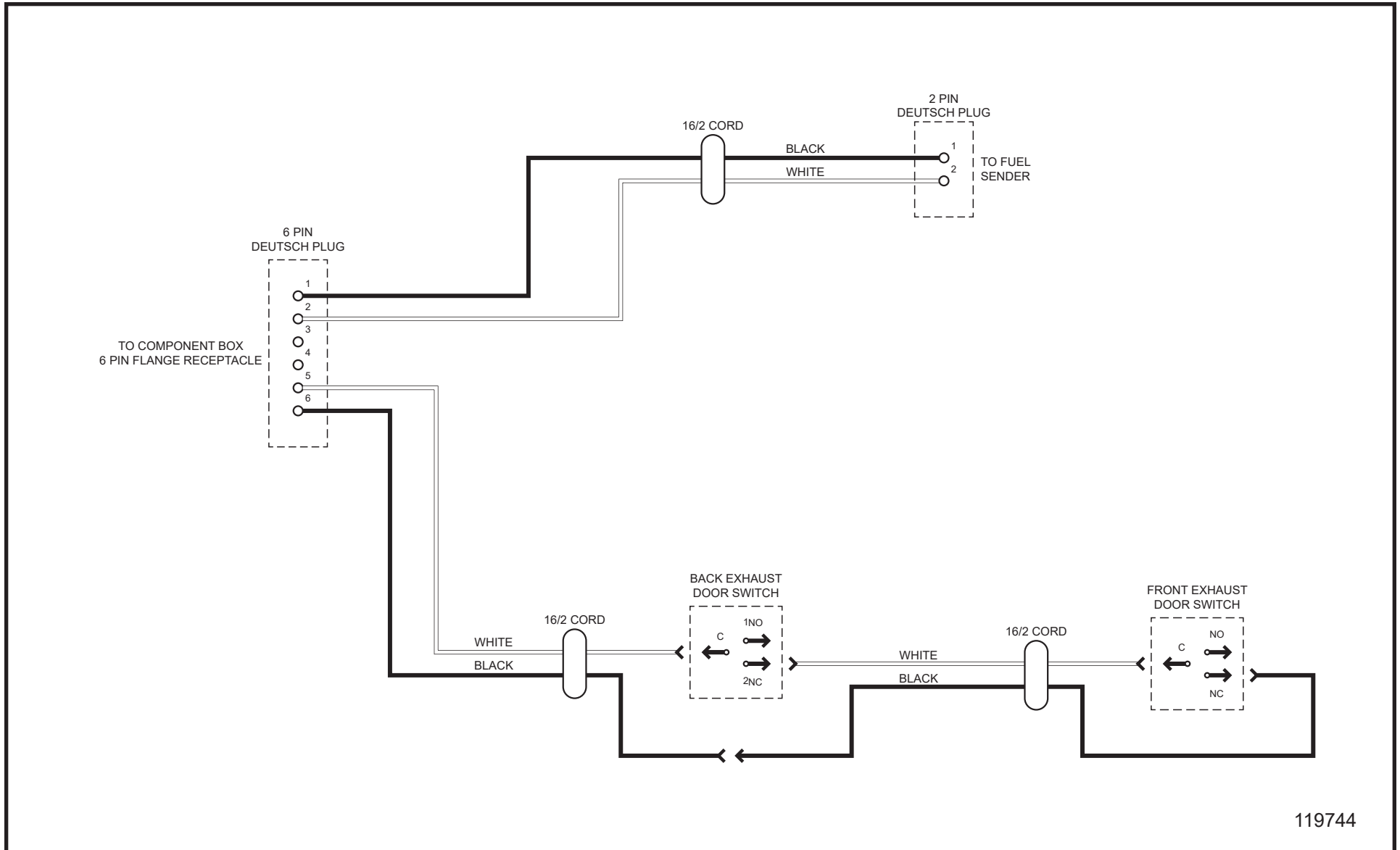

119744

MAXI-HEAT® 1MBTU

1.12 - DC Distribution Blocks 2 Heated Fuel Water Separators Schematic

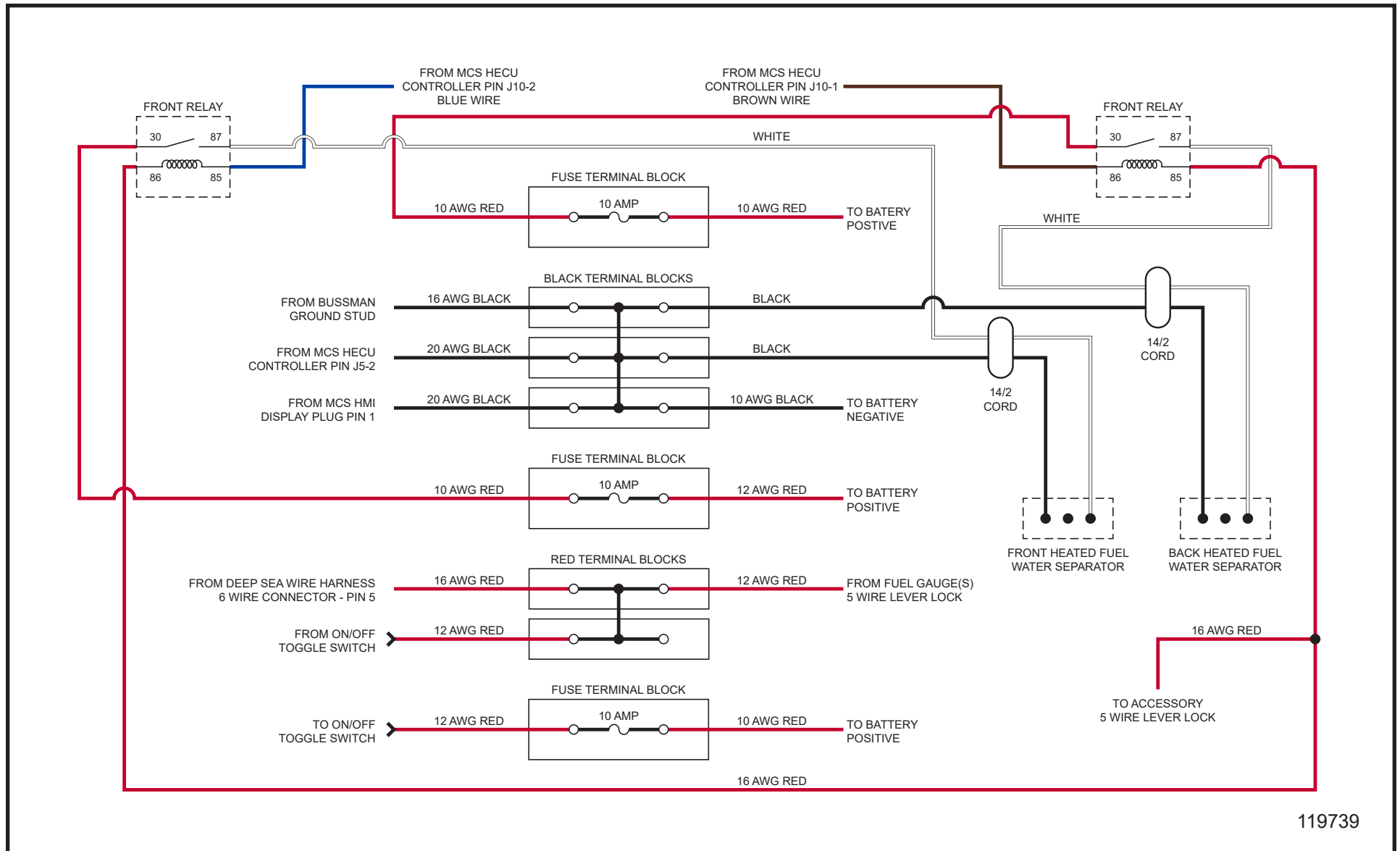

119739

1.13 - Heater Control Cord Two Heater Schematic

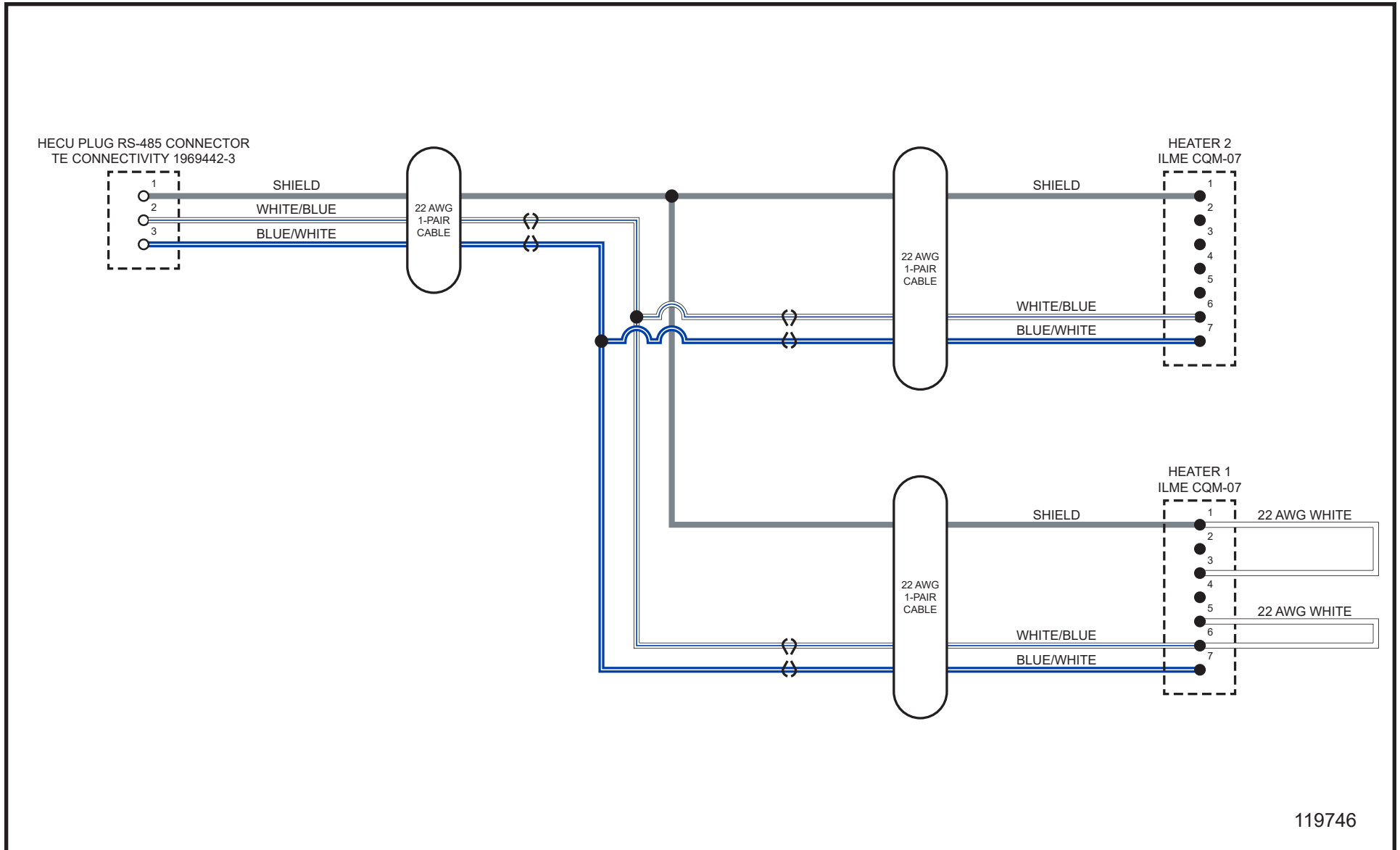

MAXI-HEAT® 1MBTU

1.14 - Tail Light Harness Schematic

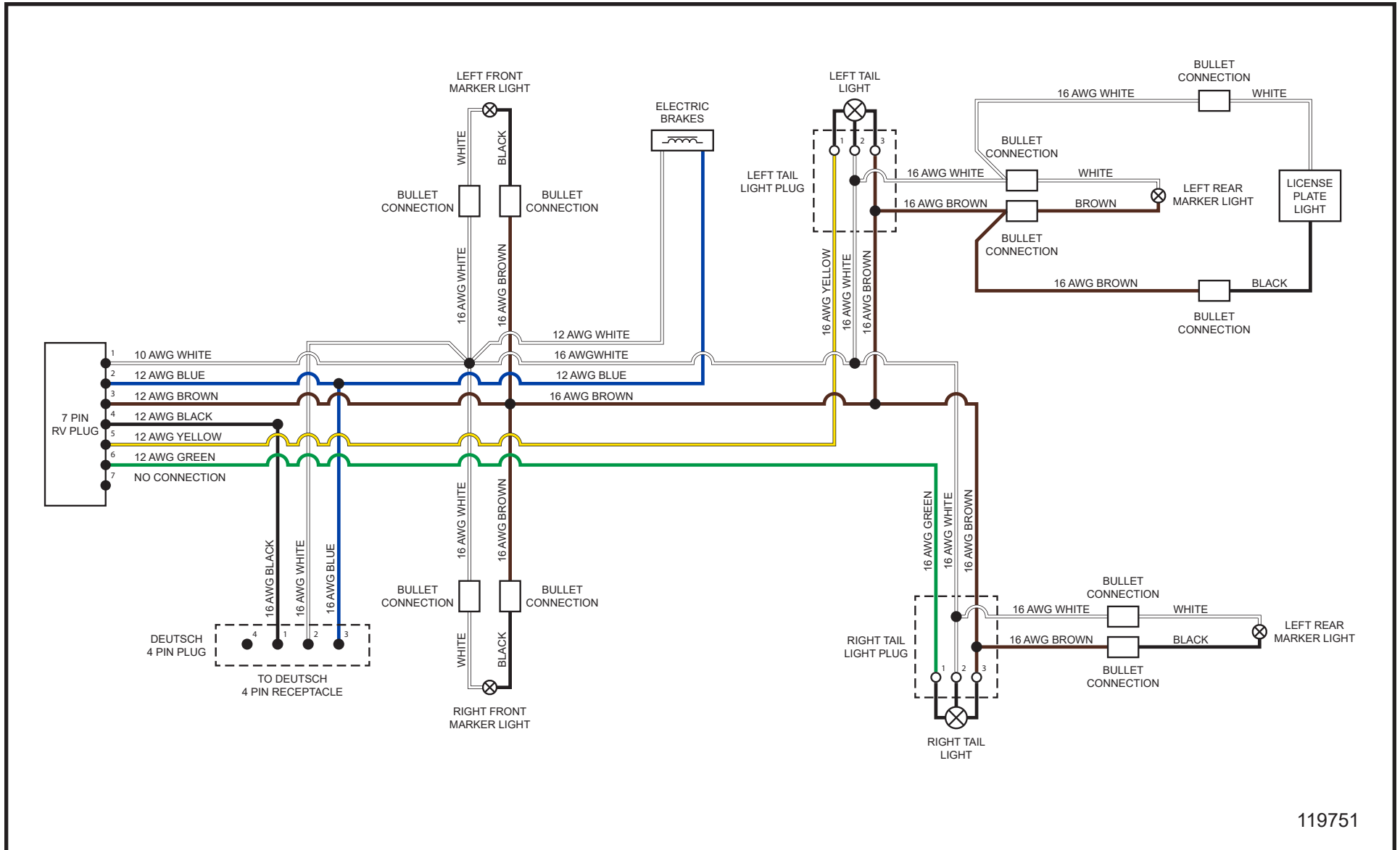

119751

1.15 - Trailer Break Away Wire Harness Schematic

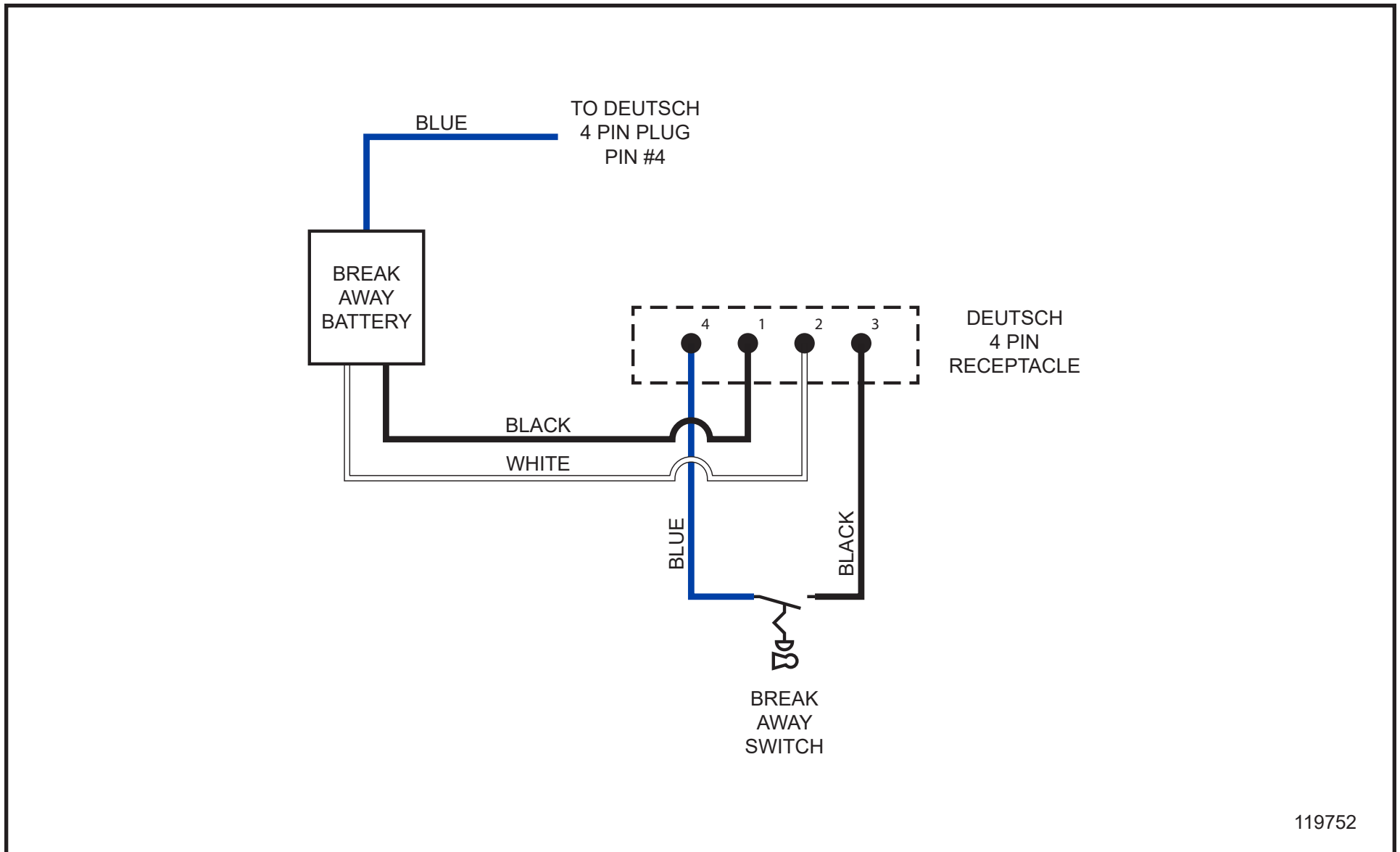

119752

MAXI-HEAT® 1MBTU

1.16 - 15A 120V GFCI Outlet Schematic

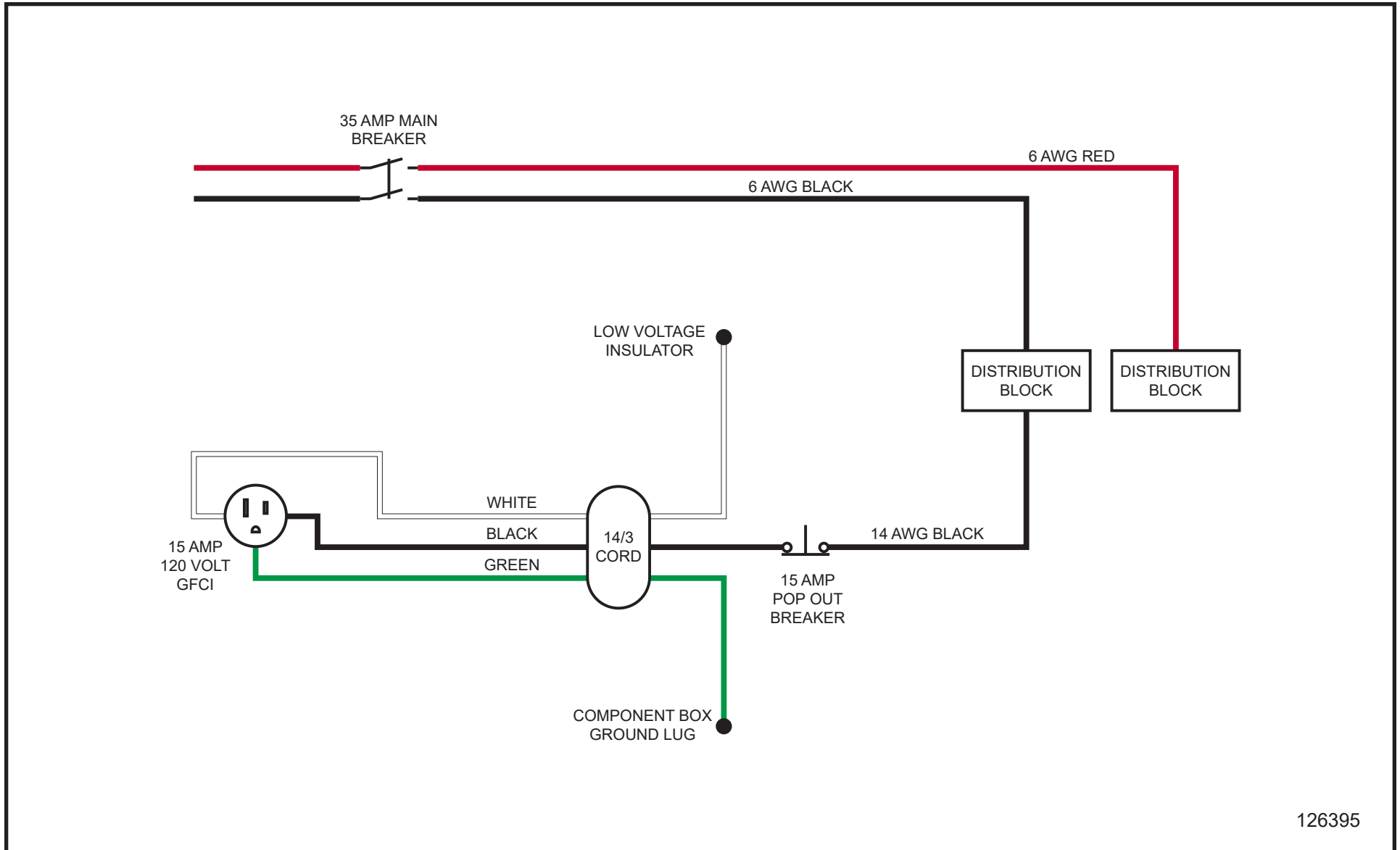

126395

1.17 - 15A 120V GFCI Outlet with Female GFCI Plug Schematic

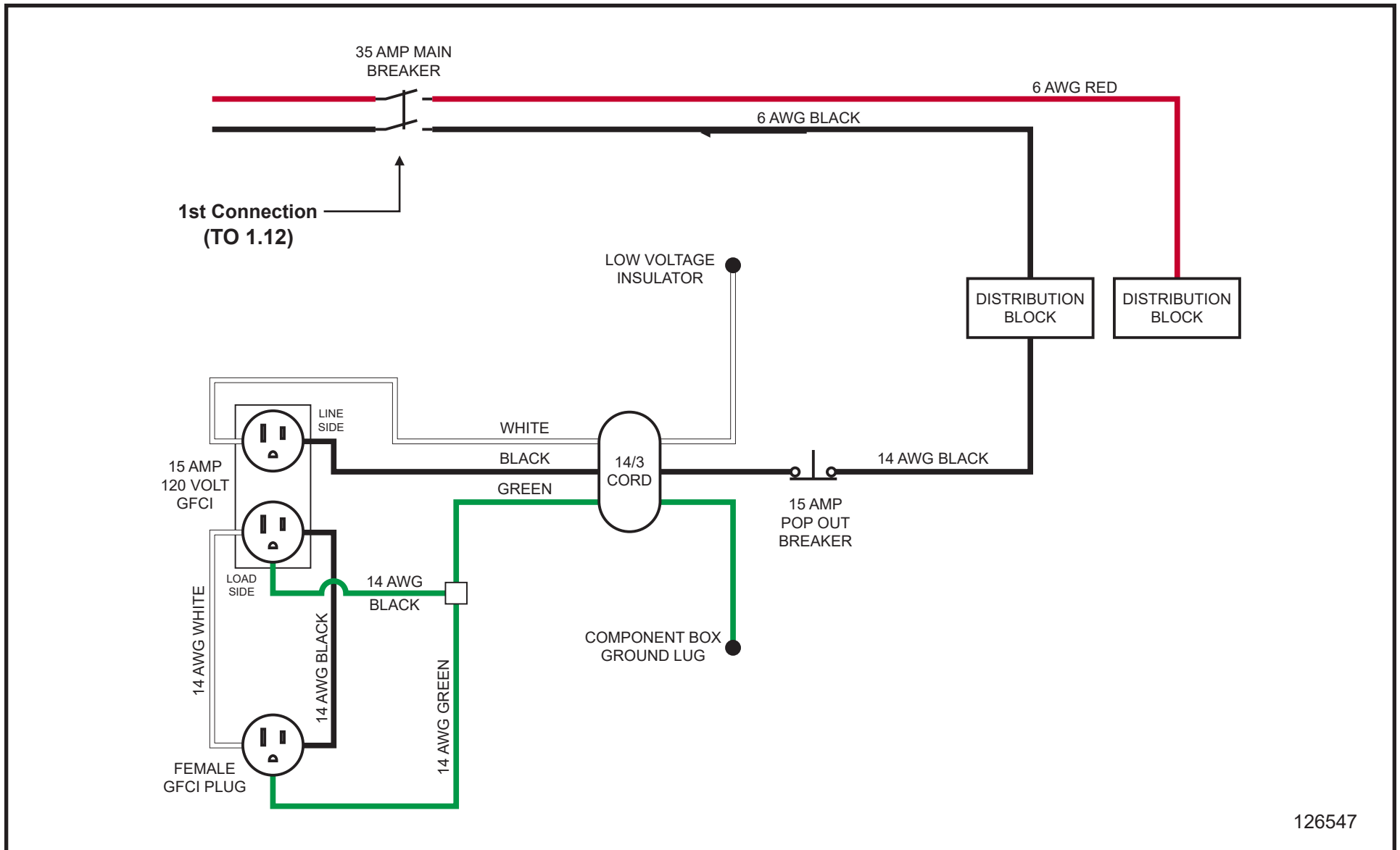

MAXI-HEAT® 1MBTU

1.18 - Trailer Curt Break Away Wire Harness Schematic

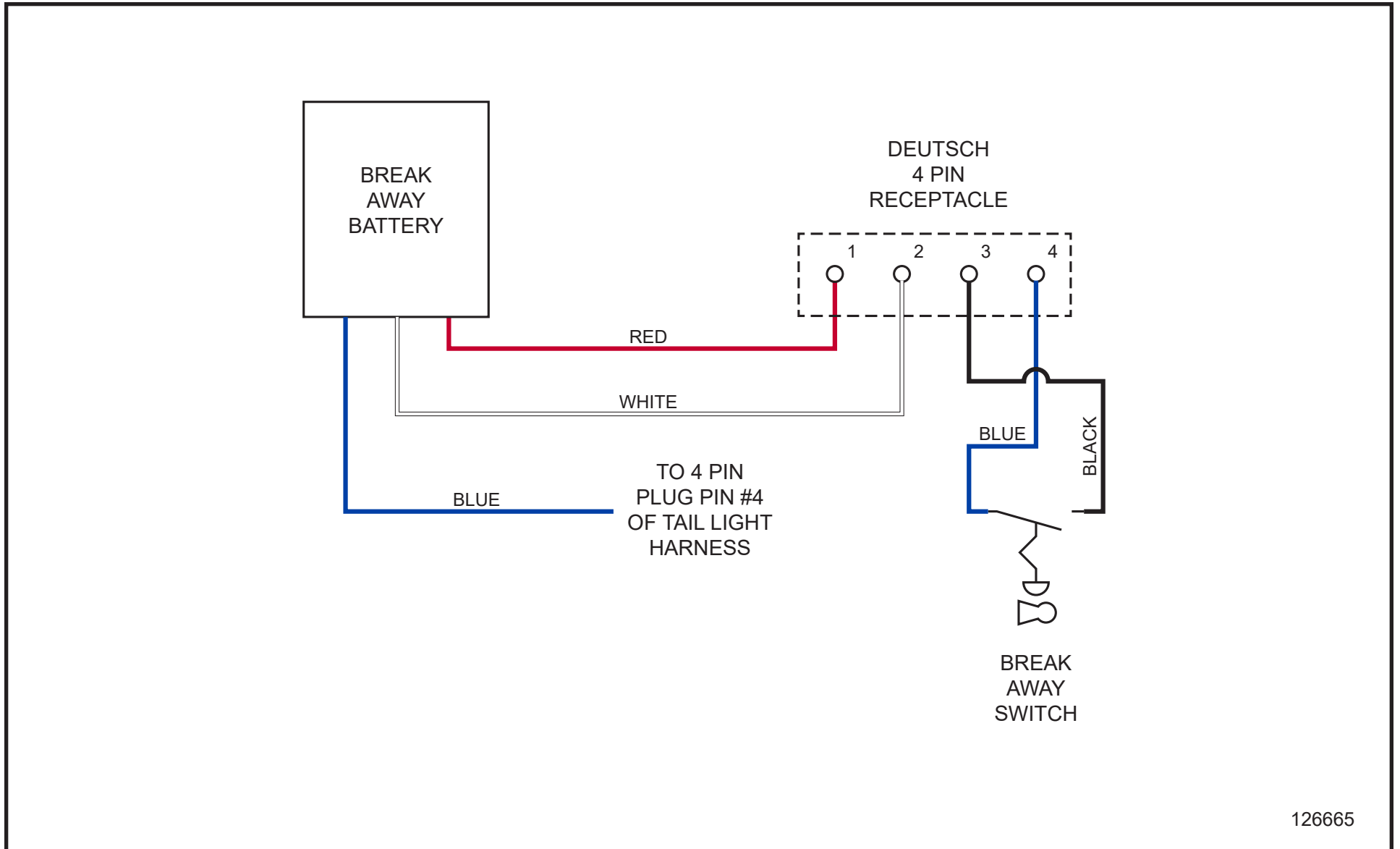

MAXI-HEAT® 1MBTU



**1502 West 4th Avenue
Holdrege, NE 68949**

**phone: (308) 995-4495 • toll free: (800) 562-1373
fax: (308) 995-5887**

www.allmand.com