



en **Parts Manual**
MAXI-LITE®



TABLE OF CONTENTS

1.0 AXLE/TONGUE/OUTRIGGERS

Axle and Wheels	(1.1)
Skid Mount	(1.2)
Fenders	(1.3)
Tongue	(1.4)
Tongue Couplers	(1.5)
Tongue Platform	(1.6)
Outriggers	(1.7)

2.0 TRAILER BASE PARTS

Engine Cradle I	(2.1)
Engine Cradle II	(2.2)
Standard Rear Panel	(2.3)
Isuzu Rear Panel	(2.4)
Power Lugs Rear Panel	(2.5)
Stringer	(2.6)
Front Panels with Standard Air Vent Deflectors	(2.7)
Front Panels with Optional Air Vent Covers	(2.8)
Front Panels Wheel Chock Blocks Option	(2.9)
Quarters Panels	(2.10)
Doors	(2.11)
Manual Canister	(2.12)

3.0 VERTICAL TOWER GROUP

Vertical Tower Section 1	(3.1)
Vertical Tower Section 2	(3.2)
Vertical Tower Section 3	(3.3)
Vertical Tower Section 4	(3.4)
Vertical Tower Section 5	(3.5)
Vertical Tower Section 4-Light Round and Light Bar	(3.6)
Vertical Tower Section 6-Light Round and Light Bar	(3.7)

TABLE OF CONTENTS

3.0 VERTICAL TOWER GROUP (CONTINUED)

Vertical Tower Components	(3.8)
Vertical Tower Standard Front Cover	(3.9)
Vertical Tower Isuzu Front Cover	(3.10)
Vertical Tower 4-Light Nycoil Tower Cord	(3.11)
4-Light SHO Lamp Junction Box	(3.12)
4-Light COB LED Lamp Junction Box	(3.13)
Vertical Tower 4-Light SMD LED Nycoil Tower Cord	(3.14)
4-Light SMD LED Lamp Tower Cord Stringer Group	(3.15)
Vertical Tower 6-Light Nycoil Tower Cord	(3.16)
6-Light SHO Lamp Junction Box	(3.17)
6-Light COB LED Lamp Junction Box	(3.18)
Vertical Tower 6-Light SMD LED Nycoil Tower Cord	(3.19)
6-Light SMD LED Lamp Tower Cord Stringer Group	(3.20)

4.0 LIGHTING GROUP

4-Light Ballast Box Install Group	(4.1)
4-Light Ballast Box Wiring Group	(4.2)
6-Light Ballast Box Install Group	(4.3)
6-Light Ballast Box Wiring Group	(4.4)
1000W 60Hz 120V Ballast Box Assembly	(4.5)
1000W 60Hz 120V HPS Ballast Box Assembly	(4.6)
1000W 50Hz 120V Ballast Box Assembly	(4.7)
1000W 50Hz 220V Ballast Box Assembly	(4.8)
1250W 60Hz 120V Ballast Box Assembly	(4.9)
4-Light COB LED Drivers Install Group	(4.10)
4-Light COB LED Drivers Wiring Group	(4.11)
6-Light COB LED Drivers Install Group	(4.12)
6-Light COB LED Drivers Wiring Group	(4.13)
4 COB LED Drivers Assembly Group	(4.14)
2 COB LED Drivers Assembly Group	(4.15)

TABLE OF CONTENTS

4.0 LIGHTING GROUP (CONTINUED)

4-Light SHO Lamp Holder Install Group	(4.16)
4-Light SHO Lamp Holder Disconnect Install Group	(4.17)
6-Light SHO Lamp Holder Install Group	(4.18)
6-Light SHO Lamp Holder Disconnect Install Group	(4.19)
SHO Lamp Holder Assembly Group	(4.20)
SHO Lamp Holder Bulb Options	(4.21)
4-Light COB LED Lamp Install Group	(4.22)
6-Light COB LED Lamp Install Group	(4.23)
COB LED Lamp	(4.24)
COB LED Lamp Diffuser	(4.25)
4-Light SMD LED Lamp Install Group	(4.26)
6-Light SMD LED Lamp Install Group	(4.27)
SMD LED Lamp Diffuser	(4.28)

5.0 CONTROL BOX GROUP

Control Box Install Group	(5.1)
Control Box Door	(5.2)
Auxiliary 208V 3PH Outlet Box	(5.3)
Power Lug Box Install Group	(5.4)
Power Lug Plate Assembly Group	(5.5)
4-Light Switches with 725 Relays	(5.6)
6-Light Switches with 725 Relays	(5.7)
4-Light Switches with Zettler Relays	(5.8)
6-Light Switches with Zettler Relays	(5.9)

6.0 CONTROL PANEL W/ ROCKER SWITCHES

SLS Key Start Bussmann Fuse Box Assembly Group	(6.1)
SLS Harness Bussmann PDM Fuse Box	(6.2)
LSC Bussmann Fuse Assembly Group	(6.3)
LSC Harness Bussmann PDM Fuse Box	(6.4)

TABLE OF CONTENTS

6.0 CONTROL PANEL W/ ROCKER SWITCHES (CONTINUED)

Isuzu DSE 5420 MK II Control Box Assembly Group	(6.5)
Isuzu DSE 5420 MK II Harness Fuse Box	(6.6)
Isuzu DSE 5420 MK II Relay and Terminal Blocks	(6.7)
Isuzu DSE L401 MK II Control Box Assembly Group	(6.8)
Isuzu DSE L401 MK II Harness Fuse Box	(6.9)
Isuzu DSE L401 MK II Relay and Terminal Blocks	(6.10)
8kW 1PH 2-30A Twistlock 1-30A RV Outlet Package I	(6.11)
8kW 1PH 2-30A Twistlock 1-30A RV Outlet Package II	(6.12)
8kW 1PH 2-30A Twistlock 1-30A RV BSB Outlet Package	(6.13)
15/20kW 1PH 3-30A Twistlock 1-50A CS6369 Outlet Package I	(6.14)
15/20kW 1PH 3-30A Twistlock 1-50A CS6369 Outlet Package II	(6.15)
15/20kW 1PH 3-30A Twistlock 1-50A CS6369 BSB Outlet Package	(6.16)
15/20kW 3PH 4-30A Twistlock Outlet Package I	(6.17)
15/20kW 3PH 4-30A Twistlock Outlet Package II	(6.18)
15/20kW 3PH 4-30A Twistlock BSB Outlet Package	(6.19)
15/20kW 1PH 2-Twistlock 1-RV 1-NEMA Outlet Package I	(6.20)
15/20kW 1PH 2-Twistlock 1-RV 1-NEMA Outlet Package II	(6.21)
15/20kW 1PH 2-Twistlock 1-RV 1-NEMA BSB Outlet Package	(6.22)
15/20kW 1PH 2-30A RV 2-50A NEMA Outlet Package	(6.23)
15/20kW 1PH 2-30A RV 2-50A NEMA BSB Outlet Package	(6.24)
Tower Rocker Switch and Interior Work Light	(6.25)

7.0 CONTROL PANEL W/ TOGGLE SWITCHES

SLS Key Start Chief Fuse Box Assembly Group	(7.1)
SLS Harness Chief PDM Fuse Box	(7.2)
DSE L401 MK II Control Box Assembly Group	(7.3)
DSE L401 MK II Fuse Box	(7.4)
Isuzu DSE L401 MK II Control Box Assembly Group	(7.5)
Isuzu DSE L401 MK II Harness Fuse Box	(7.6)
Isuzu DSE L401 MK II Relay and Terminal Blocks	(7.7)

TABLE OF CONTENTS

7.0 CONTROL PANEL W/ TOGGLE SWITCHES (CONTINUED)

DSE L401 MK II Remote Start Terminals	(7.8)
8kW 1PH 2-30A Twistlock 1-30A RV Outlet Package I	(7.9)
8kW 1PH 2-30A Twistlock 1-30A RV Outlet Package II	(7.10)
15/20kW 1PH 2-30A Twistlock 2-50A CS6369 Outlet Package	(7.11)
15/20kW 1PH 2-30A TL 1-50A RV 1-30A RV Outlet Package	(7.12)
15/20kW 1PH 2-30A RV 2-50A RV Outlet Package	(7.13)
20kW 3PH 4-30A Twistlock Outlet Package	(7.14)
15/20kW 1PH 2-30A RV 1-50A RV 1-50A TL Outlet Package	(7.15)
Distribution Blocks	(7.16)
Tower Toggle Switch and Interior Work Light	(7.17)

8.0 TRAILER ELECTRICAL

Battery Cables I	(8.1)
Battery Cables II	(8.2)
Dual Battery Cables I	(8.3)
Dual Battery Cables II	(8.4)
Battery Disconnect Cables	(8.5)
Side Marker Lights and Tail Lights	(8.6)
Breakaway Kit I	(8.7)
Breakaway Kit II	(8.8)
Emergency Stop	(8.9)
Low Fuel and Run Beacons	(8.10)

9.0 ENGINE AND FUEL TANK PARTS

Engine Isolator Mount Group	(9.1)
Engine Isolator Mount Group Isuzu	(9.2)
Fluid Containment Drain Cap	(9.3)
Fuel Tanks	(9.4)
Fuel Level Sender	(9.5)
Heated Fuel/Water Separator	(9.6)
Radiator Coolant Recovery Tank	(9.7)

TABLE OF CONTENTS

9.0 ENGINE AND FUEL TANK PARTS (CONTINUED)

Power Lug Panel Radiator Coolant Recovery Tank	(9.8)
Radiator Coolant Drain Group	(9.9)
Radiator Cold Front Group	(9.10)
Oil Drain Group	(9.11)
Oil Drain Group Isuzu	(9.12)
Oil Drain Group Kubota	(9.13)
Webasto Thermo Top C Diesel Fired Block Heater	(9.14)
Webasto Thermo Top EVO Diesel Fired Block Heater	(9.15)

10.0 CAT C1.1 ENGINE GROUP

CAT C1.1 Engine Assembly Group	(10.1)
CAT C1.1 Engine Fuel Lines	(10.2)
CAT C1.1 Webasto Thermo Top C Heater Lines	(10.3)
CAT C1.1 Webasto Thermo Top EVO Heater Lines	(10.4)
CAT C1.1 Engine Shocker Group	(10.5)
CAT C1.1 Engine PacBrake Group	(10.6)
CAT C1.1 Vertical Exhaust Pipe Option	(10.7)

11.0 CAT C1.5 TURBO ENGINE GROUP

CAT C1.5 Turbo Engine Assembly Group	(11.1)
CAT C1.5 Turbo Engine Fuel Lines	(11.2)
CAT C1.5 Turbo Webasto Thermo Top C Heater Lines	(11.3)
CAT C1.5 Turbo Webasto Thermo Top EVO Heater Lines	(11.4)
CAT C1.5 Turbo Engine Shocker Group	(11.5)
CAT C1.5 Turbo Engine PacBrake Group	(11.6)
CAT C1.5 Turbo Engine Exhaust Blanket	(11.7)

12.0 KUBOTA D1005/1105 ENGINE GROUP

Kubota D1005/1105 Engine Assembly Group	(12.1)
Kubota D1005/1105 Engine Fuel Lines	(12.2)

TABLE OF CONTENTS

12.0 KUBOTA D1005/1105 ENGINE GROUP (CONTINUED)

Kubota D1005/1105 Webasto Thermo Top C Heater Lines	(12.3)
Kubota D1005/1105 Webasto Thermo Top EVO Heater Lines	(12.4)
Kubota D1005/1105 Engine Shocker Group	(12.5)
Kubota D1005/1105 Engine PacBrake Group	(12.6)
Kubota D1005/1105 Engine Exhaust Blanket	(12.7)
Kubota D1005/1105 Vertical Exhaust Pipe Option I	(12.8)
Kubota D1005/1105 Vertical Exhaust Pipe Option II	(12.9)

13.0 ISUZU 4LE2T ENGINE GROUP

Isuzu 4LE2T Engine DSE 4520 Assembly Group	(13.1)
Isuzu 4LE2T Engine DSE L401 Assembly Group I	(13.2)
Isuzu 4LE2T Engine DSE L401 Assembly Group II	(13.3)
Isuzu 4LE2T Engine Fuel Lines with Fuel Cooler	(13.4)
Isuzu 4LE2T Engine Fuel Lines	(13.5)
Isuzu 4LE2T Webasto Thermo Top C Heater Lines	(13.6)
Isuzu 4LE2T Webasto Thermo Top EVO Heater Lines	(13.7)
Isuzu 4LE2T Engine Shocker Group	(13.8)
Isuzu 4LE2T Engine PacBrake Group	(13.9)
Isuzu 4LE2T Engine Exhaust Blanket	(13.10)

14.0 GENERATOR GROUP

8kW Marathon Generator	(14.1)
8kW Marathon Generator Cord Install Group	(14.2)
15kW 1PH Marathon Generator	(14.3)
15kW 1PH Marathon Generator Cord Install Group	(14.4)
20kW 1PH Marathon Generator	(14.5)
20kW 1PH Marathon Generator Cord Install Group	(14.6)
20kW 1PH Linz Generator	(14.7)
20kW 1PH Linz Generator Cord Install Group	(14.8)
20kW 3PH Coliseum Generator	(14.9)
20kW 3PH Coliseum Generator Cord Install Group	(14.10)

TABLE OF CONTENTS

15.0 DECAL GROUP

Door Branding Decals	(15.1)
Domestic English/French Safety Decals	(15.2)
International Wordless Safety Decals	(15.3)
Electrical Decals	(15.4)
Conspicuity Tape	(15.5)

1.1 - Axle and Wheels

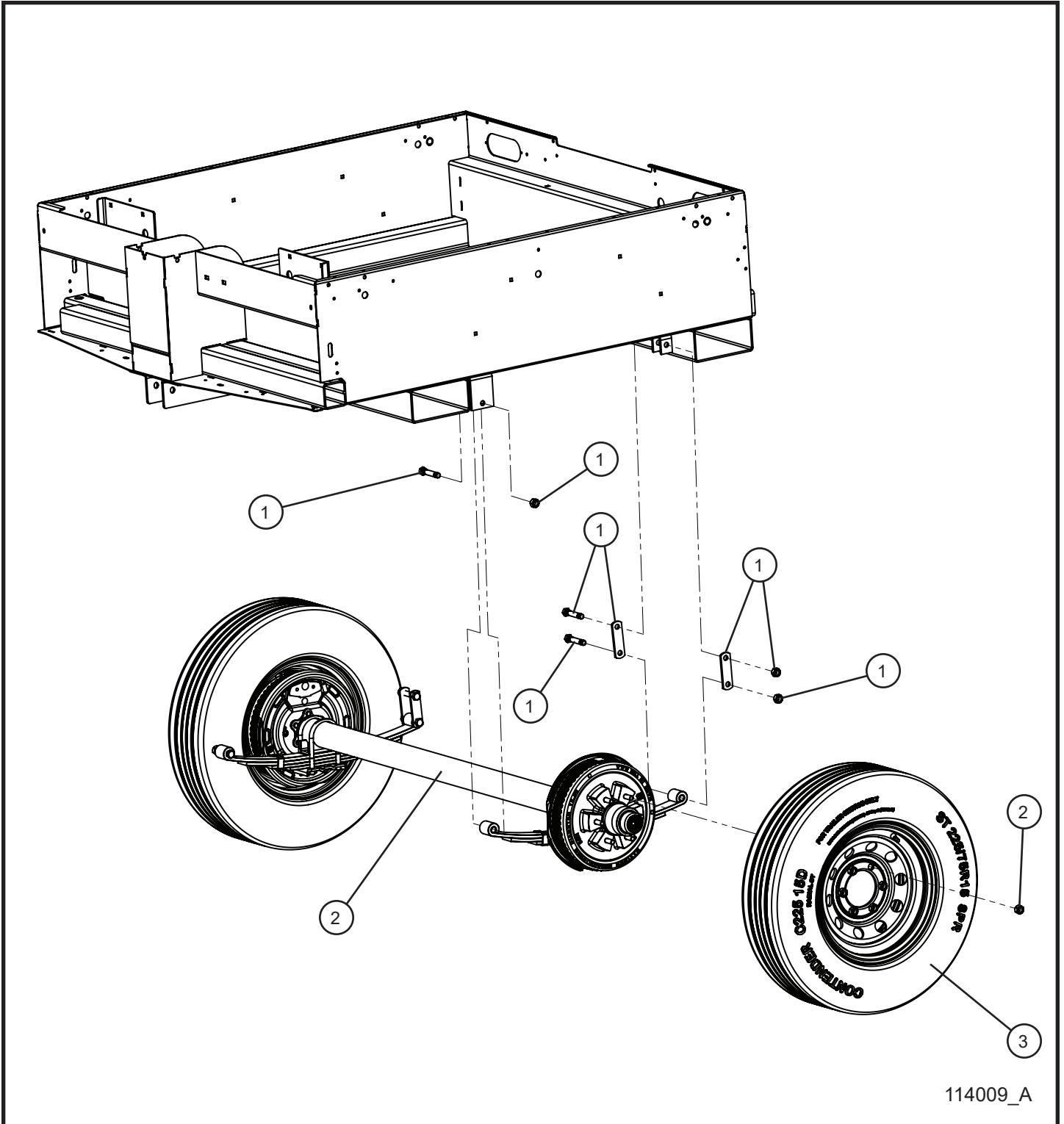

1.1 - Axle and Wheels

Item	Part No.	Part Description	Qty.
1	117120	SUSPENSION KIT SINGLE AXLE	1
2	110278	AXLE 5200LBS ELECTRIC BRAKE MAXI-LITE	1
3	110331	WHEEL-6 BOLT ST225/75R15 LOAD RANGE D	2
NS	022200	1/4 LOOM FLEX GUARD x 23.0	1

*NS - NOT SHOWN

1.2 - Skid Mount

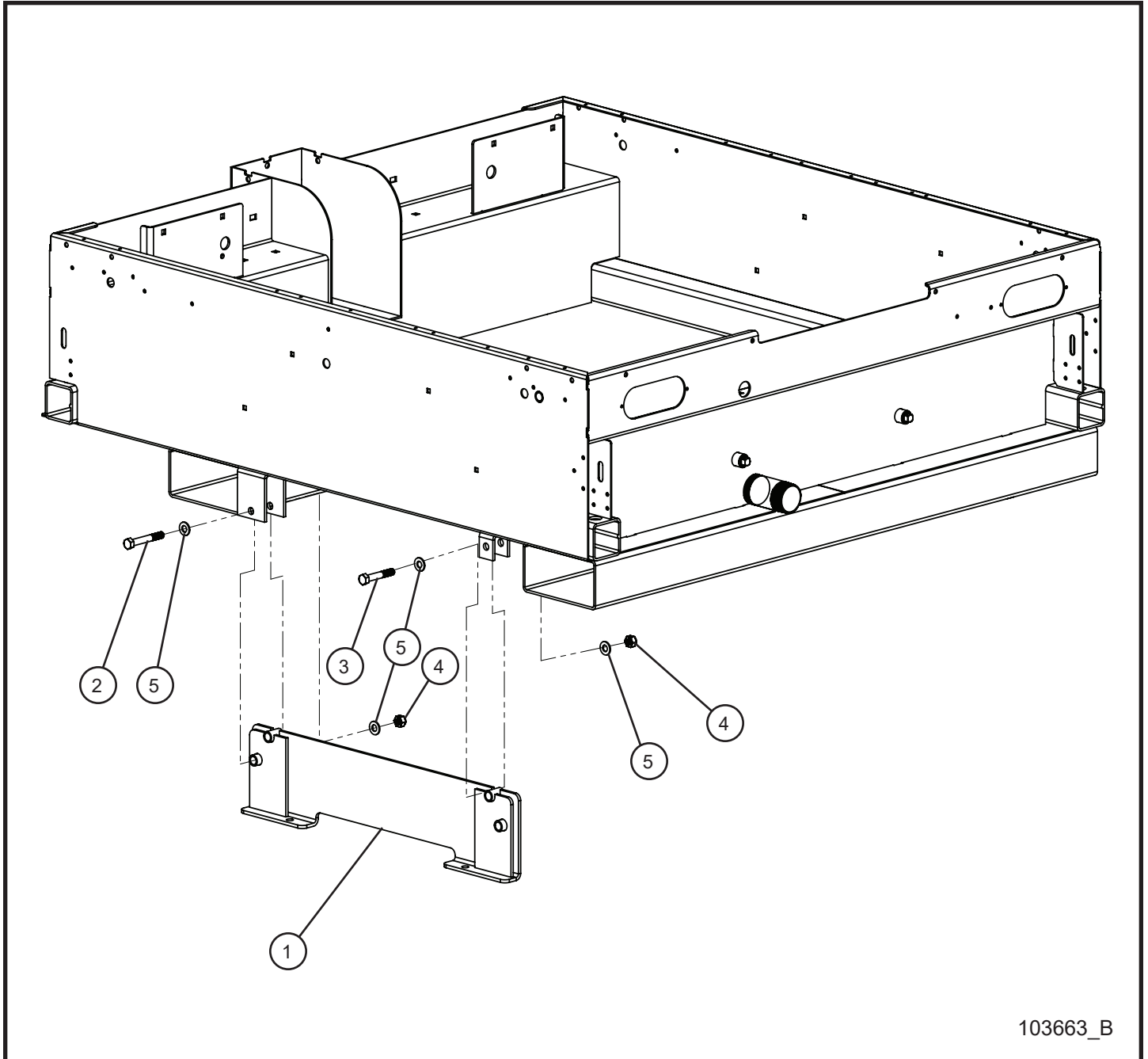

1.2 - Skid Mount

Item	Part No.	Part Description	Qty.
1	113141P	SKID MOUNT MAXI II	2
2	046215	1/2-13 x 3 1/2 HEX HEAD BOLT	2
3	046210	1/2-13 x 3 HEX HEAD BOLT	2
4	044048	1/2-13 NYLOCK HEX NUT	4
5	047025	1/2 FLAT WASHER	8

1.3 - Fenders

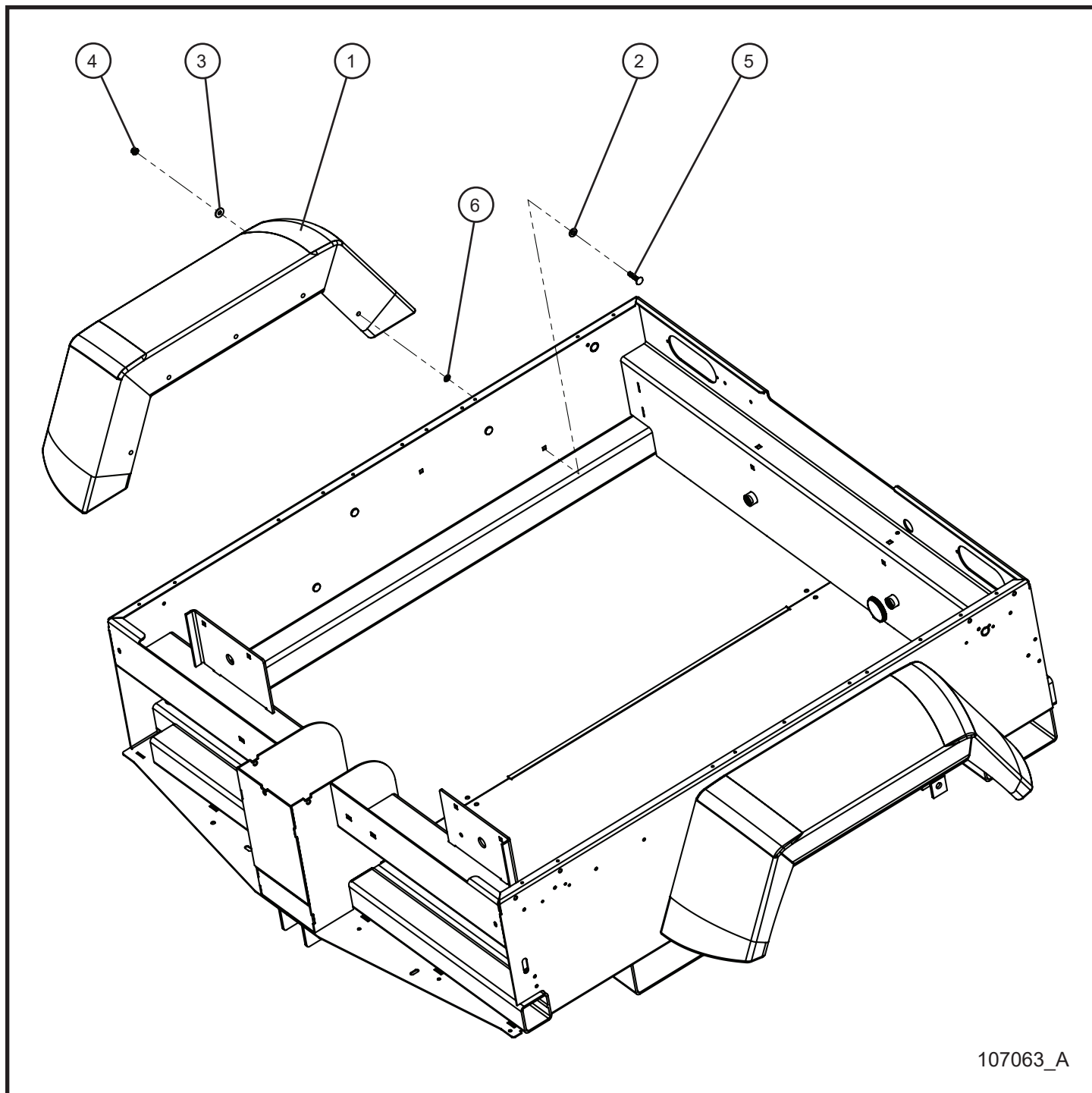

107063_A

1.3 - Fenders

Item	Part No.	Part Description	Qty.
1	103066	FENDER ROTATION MOLDED 15 INCH EMBEDDED DECAL	2
2	100644	RUBBER WASHER BLACK NEOPRENE	8
3	047010	5/16 FLAT WASHER PL	8
4	044031	5/16-18 KEPS HEX NUT PL	8
5	053023	5/16-18 x 1 1/2 CARRIAGE BOLT PL	8
6	045217	5/16 PUSH NUT	8

1.4 - Tongue

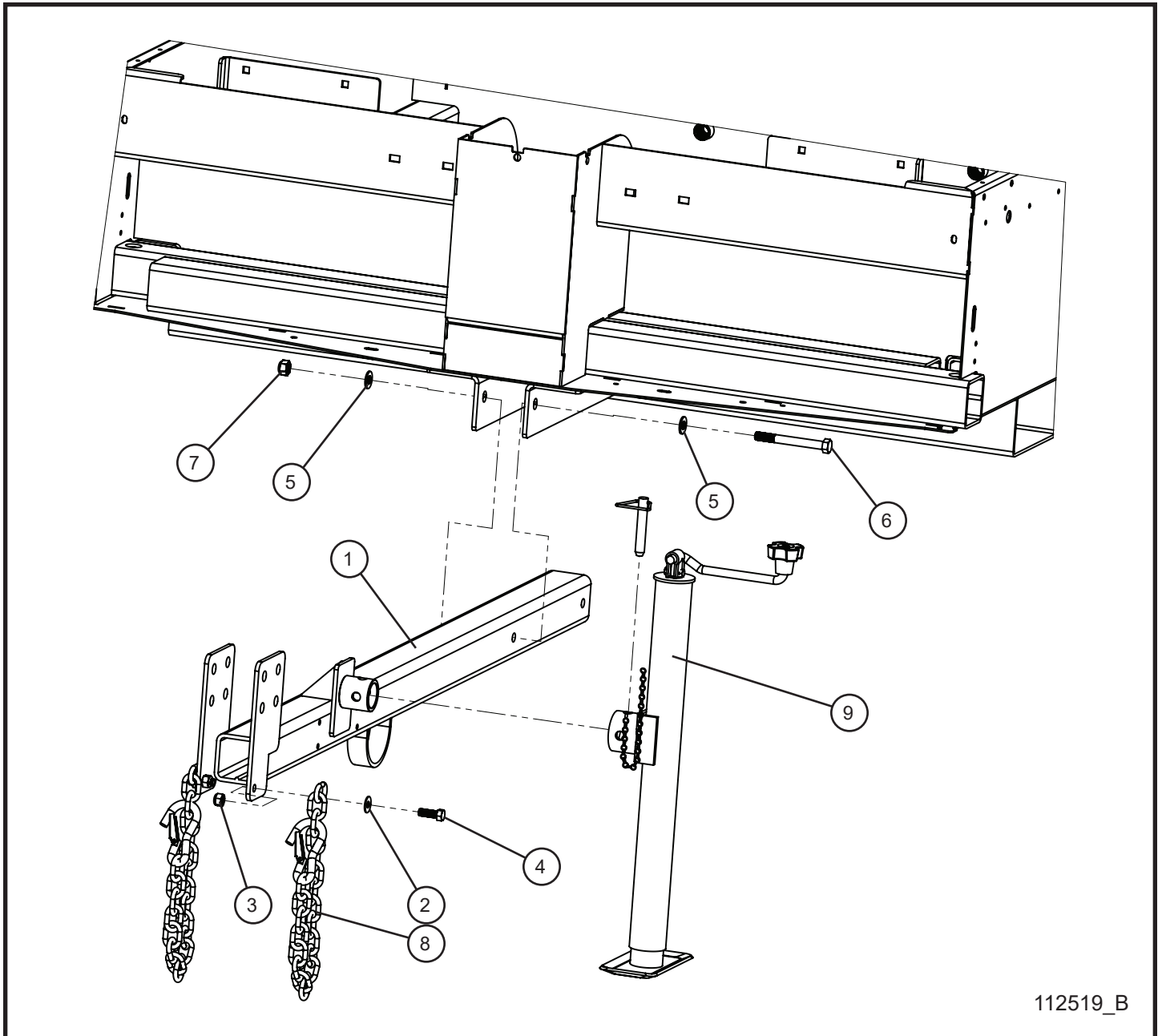

1.4 - Tongue

Item	Part No.	Part Description	Qty.
1	112377P	TONGUE WELDMENT REVERSIBLE COUPLER	1
2	047015	3/8 FLAT WASHER	2
3	044043	7/16-14 NYLOCK HEX NUT	2
4	046159	7/16-14 x 1 1/4 HEX HEAD BOLT	2
5	047025	1/2 FLAT WASHER	4
6	046225	1/2-13 x 4 1/2 HEX HEAD BOLT	2
7	044048	1/2-13 NYLOCK HEX NUT	2
8	049040	SAFETY CHAIN	2
9	108727	TOP CRANK JACK TUBE MOUNT	2

1.5 - Tongue Couplers

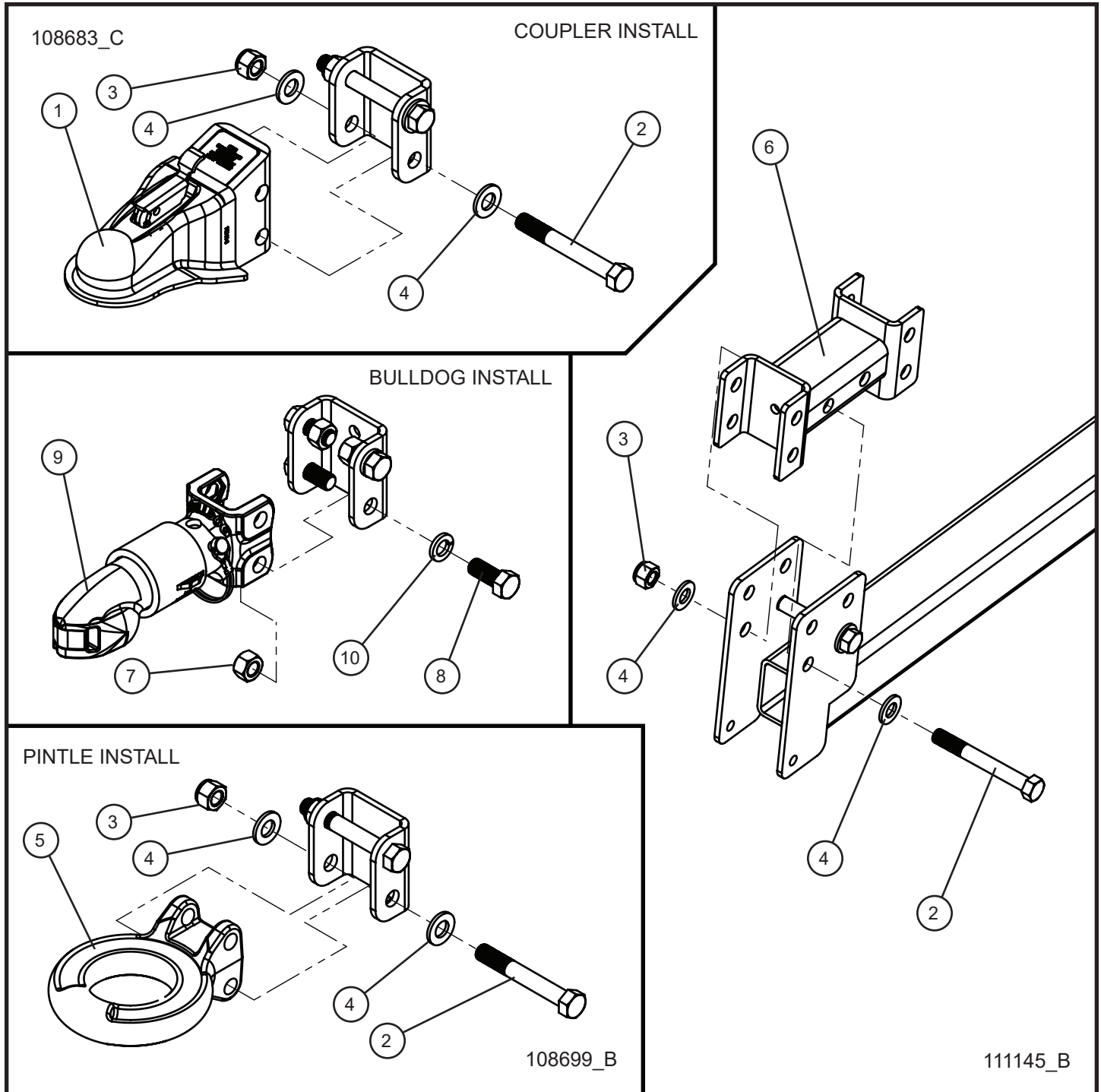

1.5 - Tongue Couplers

Item	Part No.	Part Description	Qty.
1	109977	COUPLER BALL 2.00 ADJUSTABLE STAMPED	1
	109976	COUPLER BALL 2.313 ADJUSTABLE STAMPED	1
2	046255	5/8-11 x 5 HEX HEAD BOLT	4
3	044053	5/8-11 NYLOCK HEX NUT	4
4	047031	5/8 FLAT WASHER	10
5	106720	RING PINTLE 3.00 ADJUSTABLE	1
6	111148P	REVERSIBLE COUPLER TONGUE MOUNT	1
7	044050	5/8-11 HEX NUT	4
8	046245	5/8-11 x 1 1/2 HEX HEAD BOLT	4
9	109978	COUPLER BALL 2.00 BULLDOG HITCH 7,000 LBS	1
	109979	COUPLER BALL 2.313 BULLDOG HITCH 12,500 LBS	1
10	043101	5/8 SPLITLOCK WASHER	4

1.6 - Tongue Platform

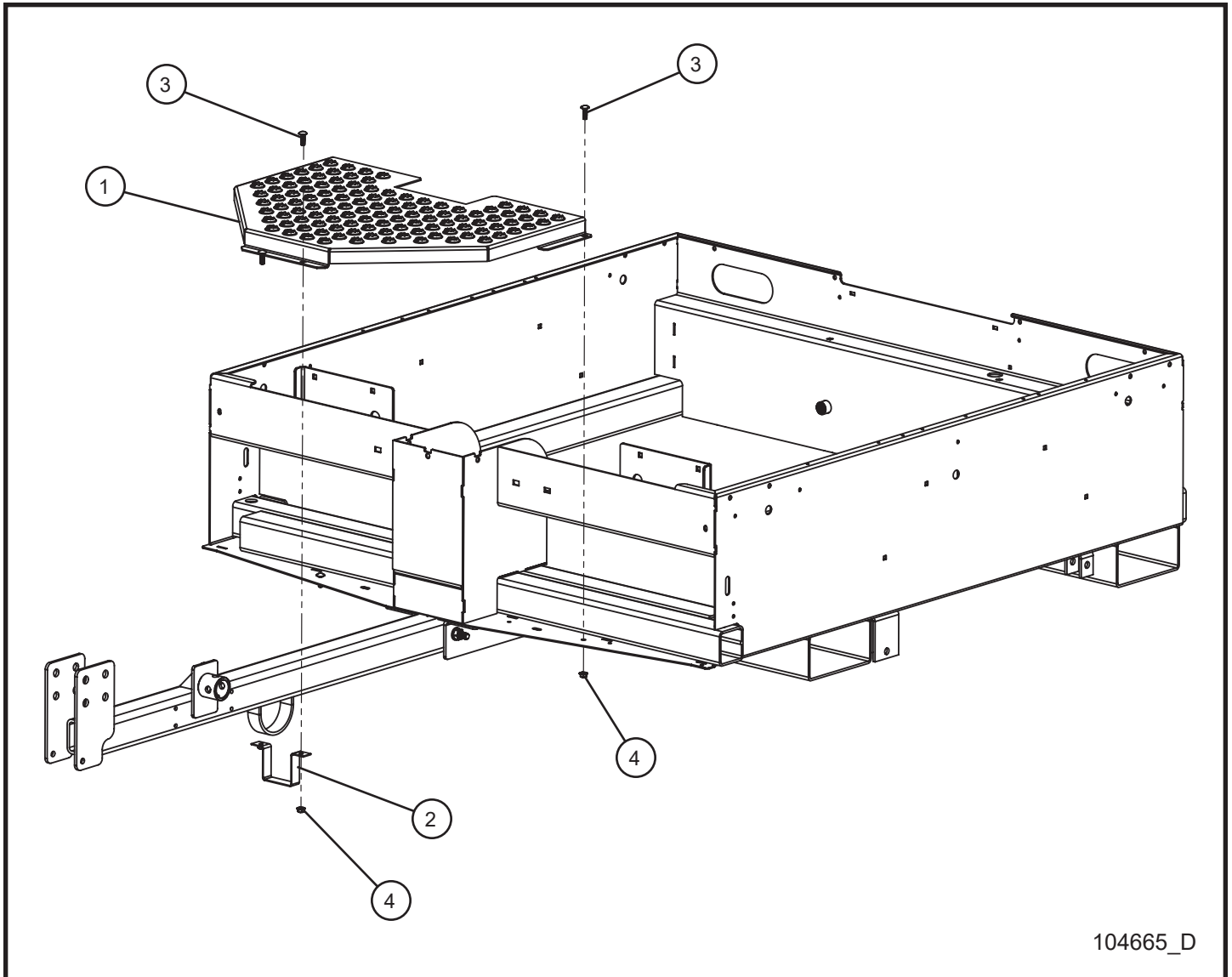

104665_D

1.6 - Tongue Platform

Item	Part No.	Part Description	Qty.
1	120382P	PUNCHED GRIP STEP PLATE MAXI-LITE	1
2	104530P	TONGUE STRAP GRIP STEP	1
3	053020	5/16-18 x 1 CARRIAGE BOLT	4
4	057006	5/16-18 SERRATED FLANGE NUT	4

1.7 - Outriggers

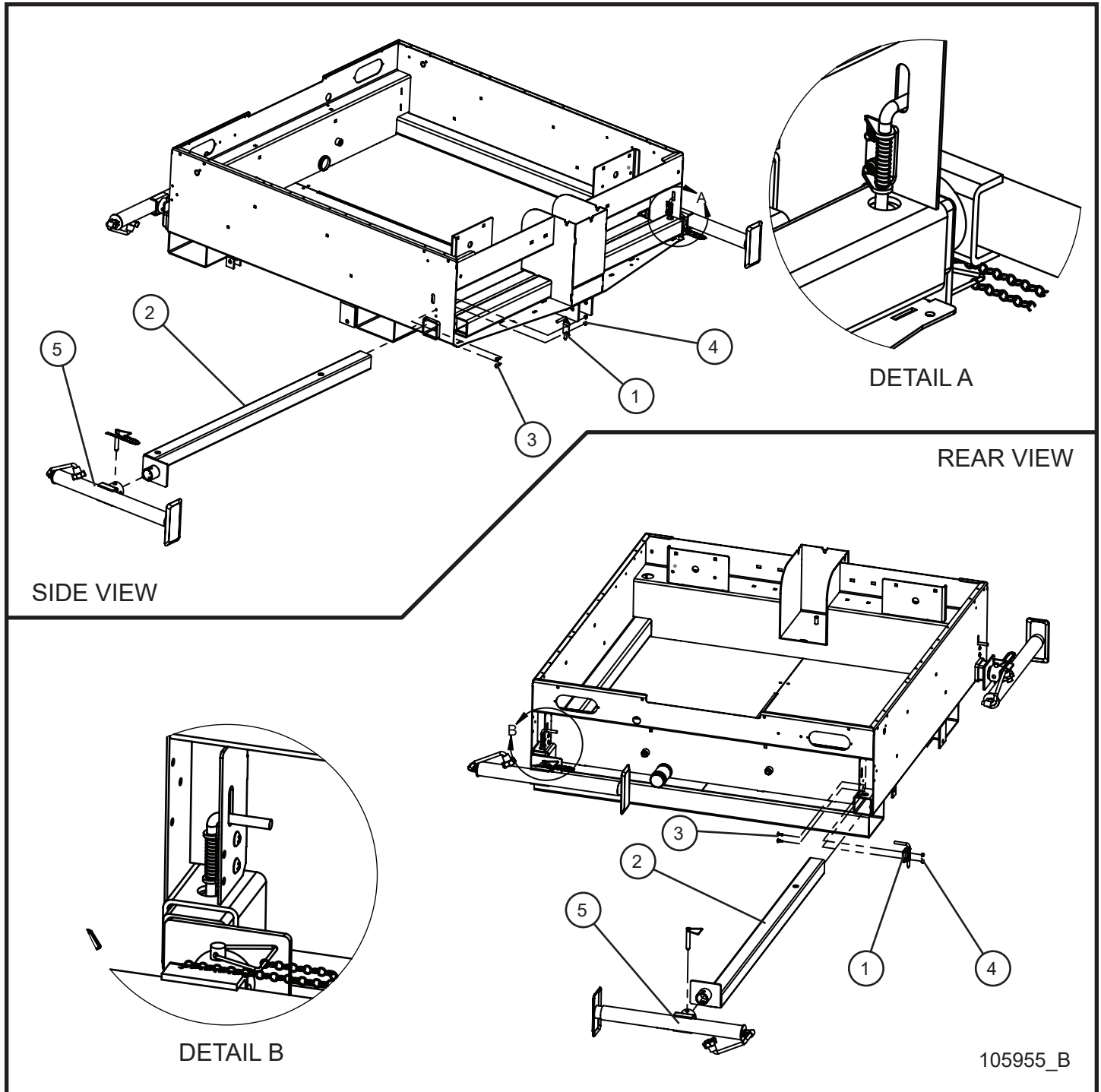

1.7 - Outriggers

Item	Part No.	Part Description	Qty.
1	650723	PIN OUTRIGGER RETENTION RIGHT	4
2	105946P	HD OUTRIGGER WELDMENT MAXI II	4
3	056002	1/4-20 x 3/4 HEX SERRATED FLANGE SCREW	8
4	057001	1/4-20 HEX NYLOCK FLANGE NUT	8
5	108727	JACK TOP CRANK TUBE MOUNT	4

2.1 - Engine Cradle I

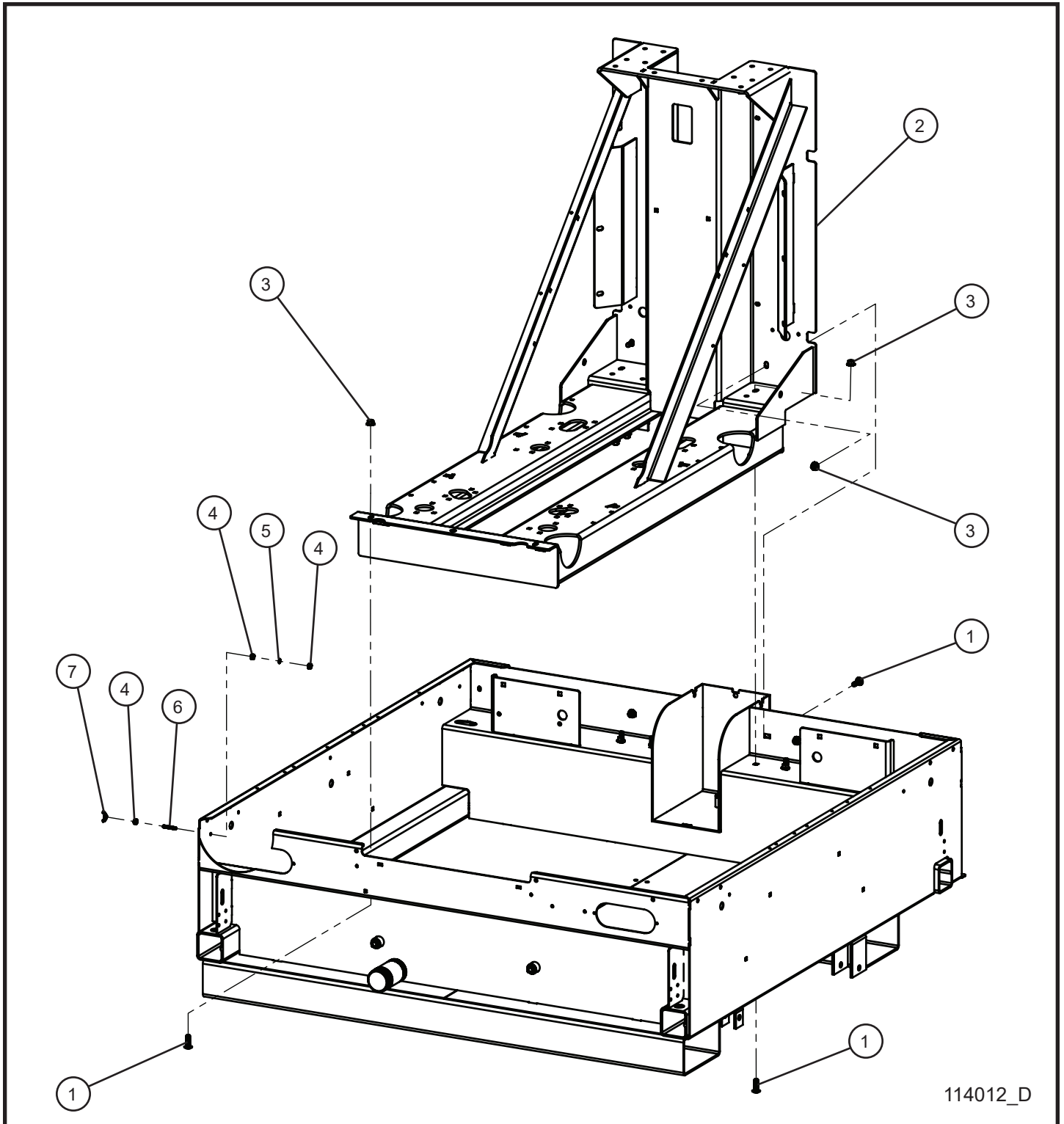

114012_D

2.1 - Engine Cradle I

Item	Part No.	Part Description	Qty.
1	100670	3/8-16 x 1 1/4 CARRIAGE BOLT	22
2	113631P	ENGINE CRADLE REINFORCED MAXI-LITE II	1
3	044029	3/8-16 SERRATED FLANGLE NUT	22
4	044021	1/4-20 KEPS HEX NUT	3
5	043050	1/4 INTERNAL TOOTH LOCK WASHER	1
6	045003	1/4-20 x 1-1/2 STUD	1
7	330494	1/4-20 WING NUT	1

2.2 - Engine Cradle II

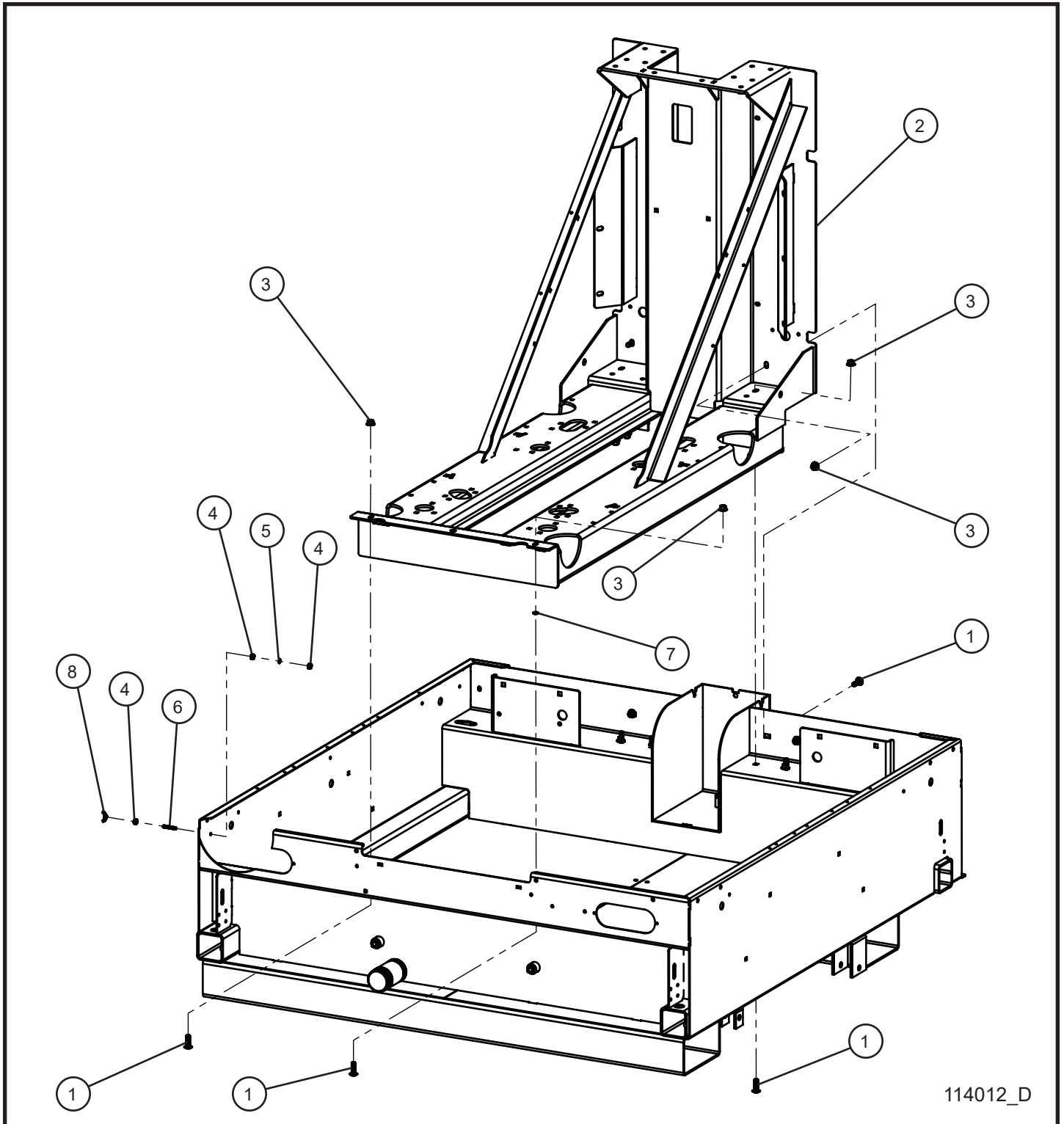

114012_D

2.2 - Engine Cradle II

Item	Part No.	Part Description	Qty.
1	100670	3/8-16 x 1 1/4 CARRIAGE BOLT	22
2	120060P	ENGINE CRADLE REINFORCED MAXI-LITE II	1
3	044029	3/8-16 SERRATED FLANGLE NUT	22
4	044021	1/4-20 KEPS HEX NUT	3
5	043050	1/4 INTERNAL TOOTH LOCK WASHER	1
6	045003	1/4-20 x 1-1/2 STUD	1
7	043070	3/8 INTL TOOTH LOCK WASHER	1
8	330494	1/4-20 WING NUT	1

2.3 - Standard Rear Panel

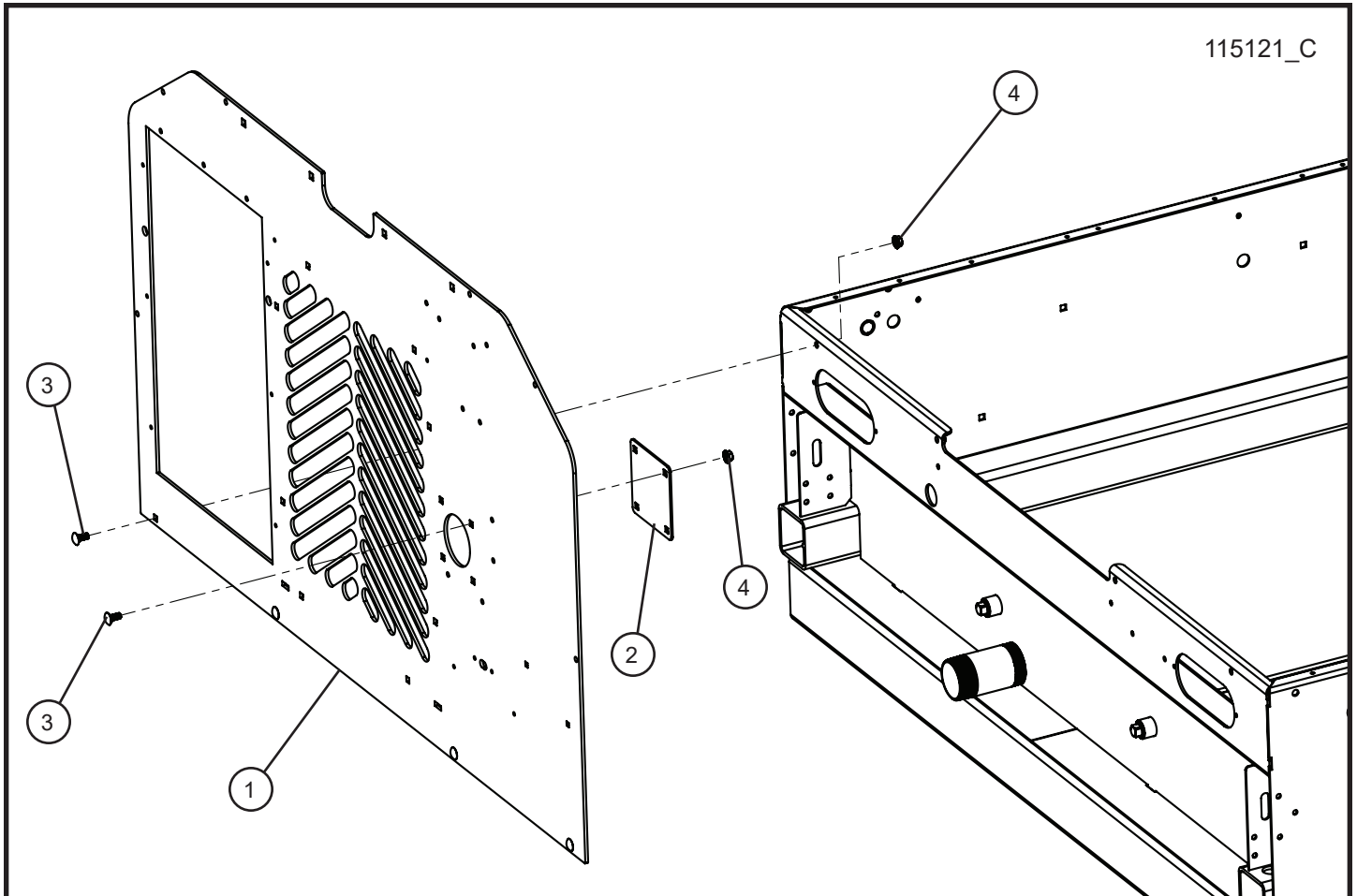

2.3 - Standard Rear Panel

Item	Part No.	Part Description	Qty.
1	115161P	STANDARD RADIATOR MOUNTED REAR PANEL	1
2	106250P	STANDARD MUFFLER HOLE PLATE	1
3	053020	5/16-18 X 1 CARRIAGE BOLT	8
4	057006	5/16-18 SERRATED FLANGE NUT	8

2.4 - Isuzu Rear Panel

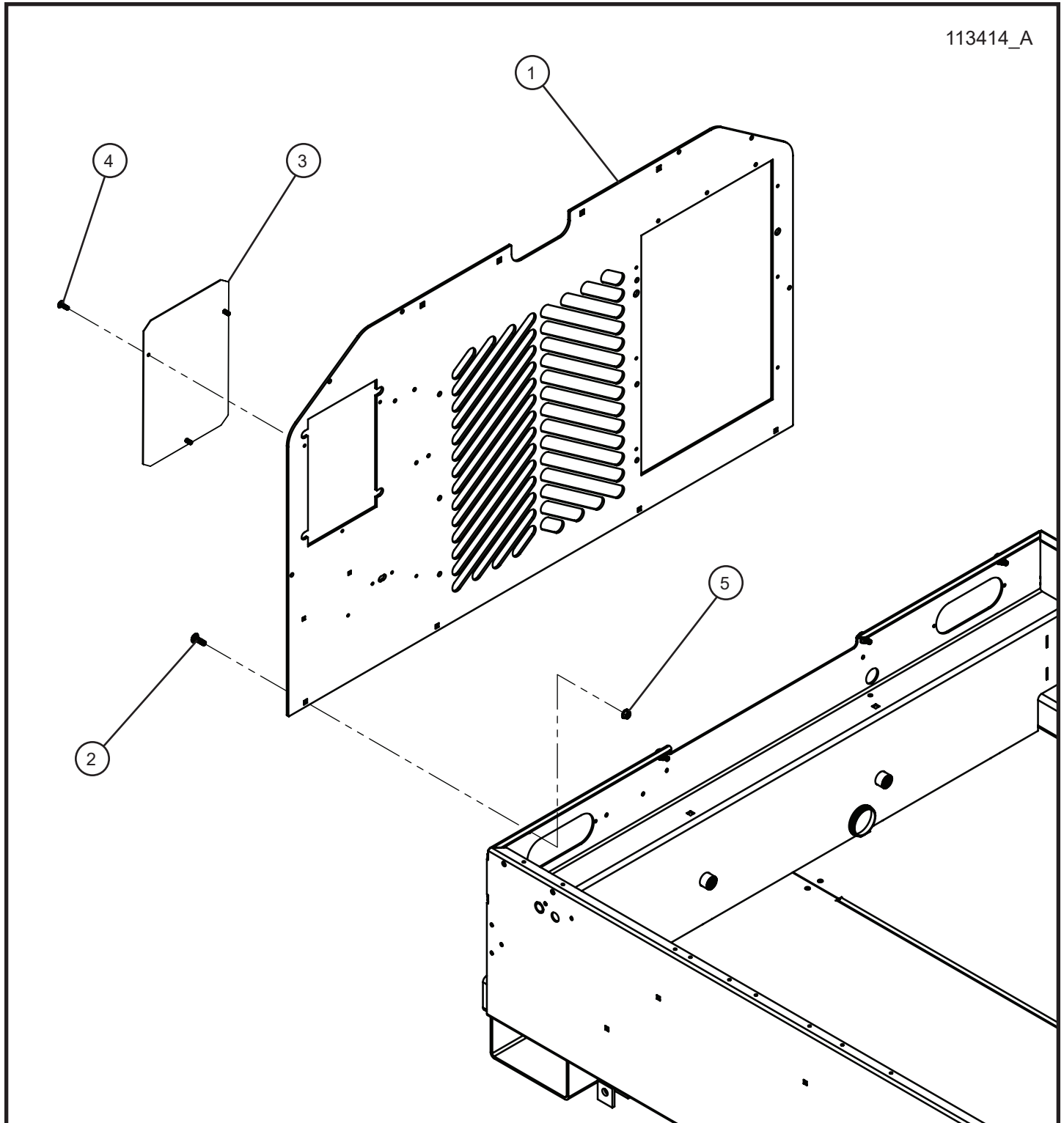

2.4 - Isuzu Rear Panel

Item	Part No.	Part Description	Qty.
1	107010P	ISUZU 4LE2T REAR PANEL	1
2	053020	5/16-18 X 1 CARRIAGE BOLT	4
3	107114P	MAXI REAR PANEL CUTOUT FILLER PLATE	1
4	041070	1/4-20 x 3/4 SL-HEX WASHER HEAD MACHINE SCREW	3
5	057006	5/16-18 SERRATED FLANGE NUT	4

2.5 - Power Lugs Rear Panel

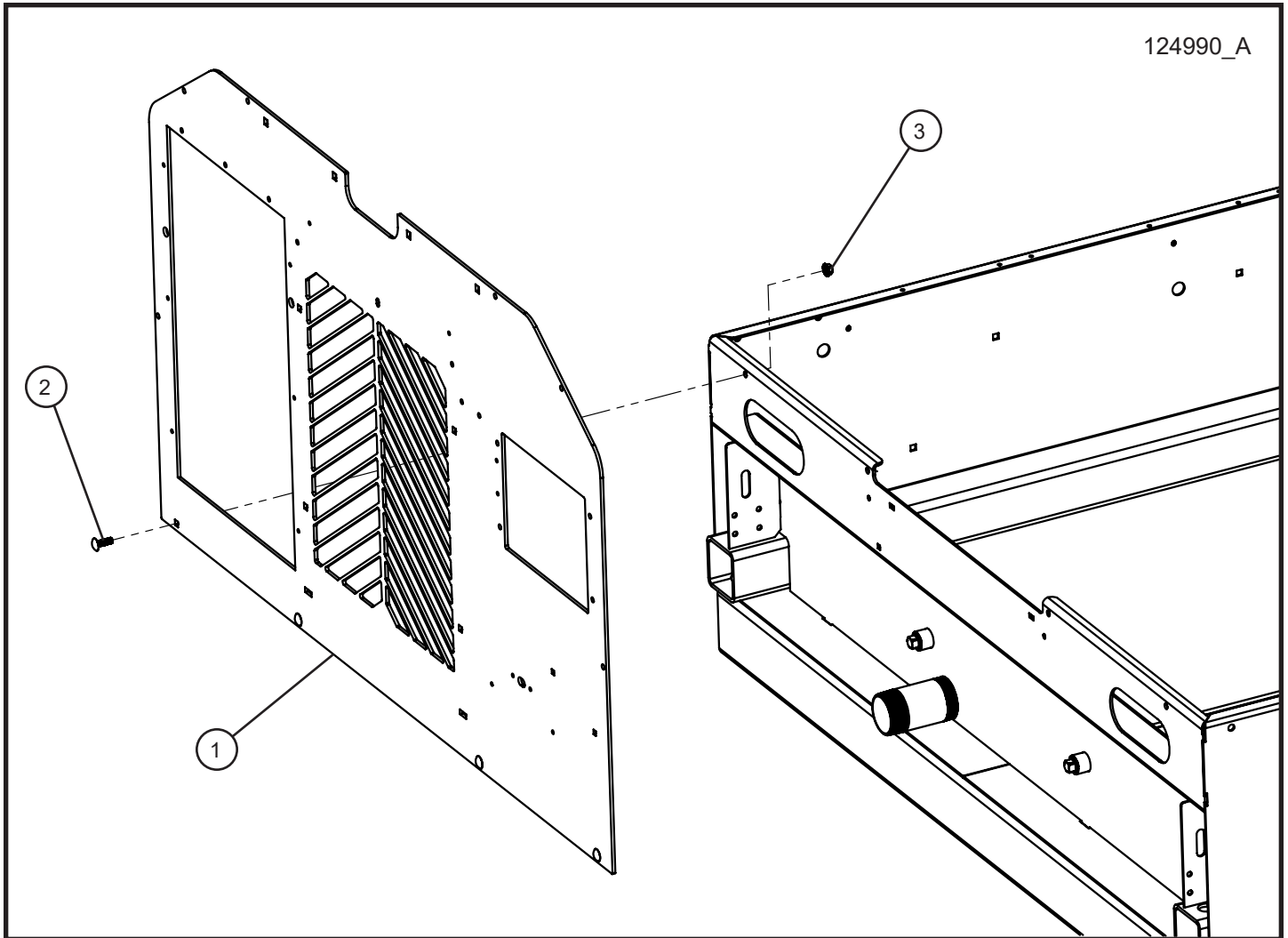

2.5 - Power Lugs Rear Panel

Item	Part No.	Part Description	Qty.
1	124964P	REAR PANEL POWER LUGS MAXI-LITE & MP15XR	1
2	053020	5/16-18 X 1 CARRIAGE BOLT	4
3	057006	5/16-18 SERRATED FLANGE NUT	4

2.6 - Stringer

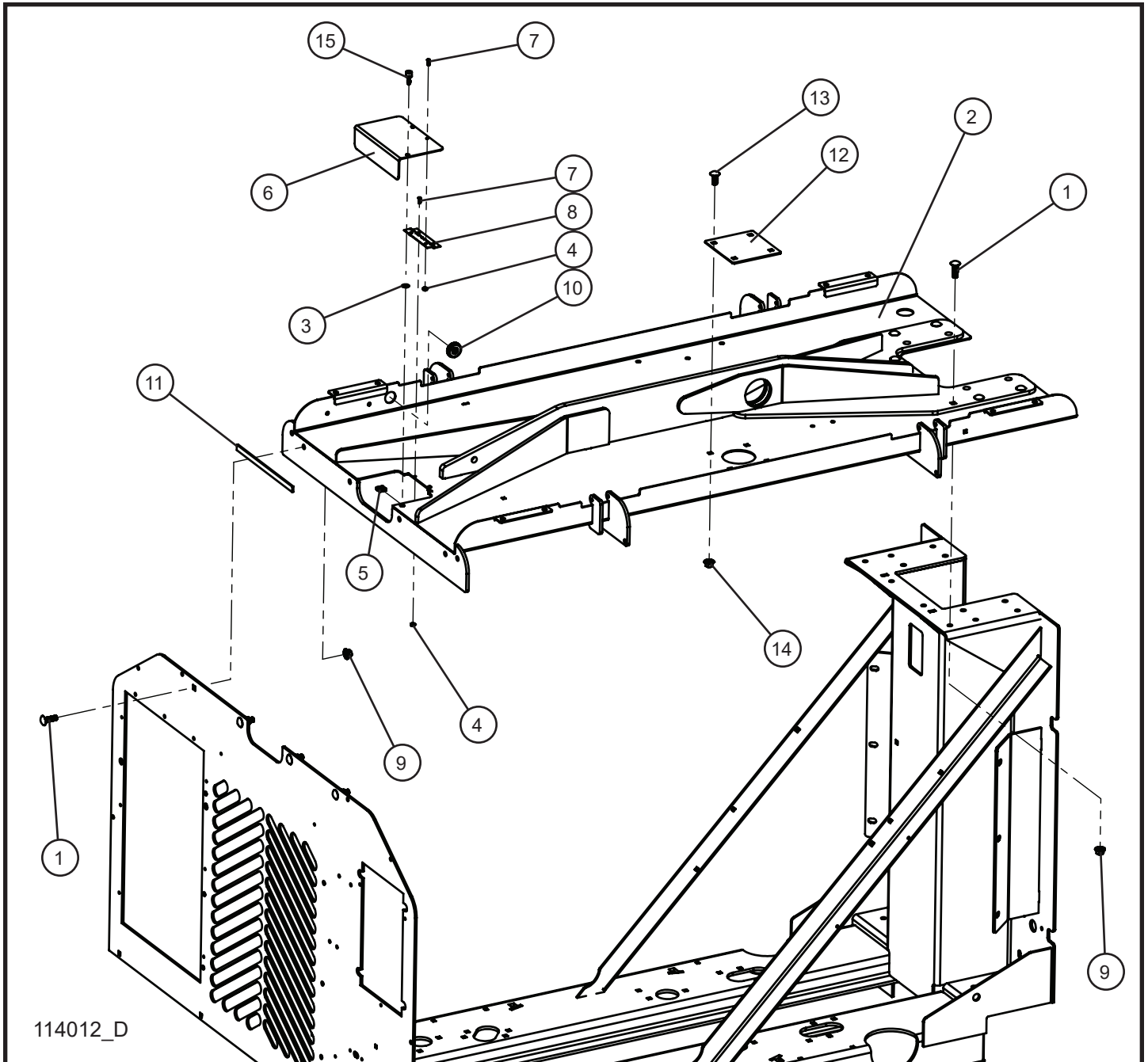

2.6 - Stringer

Item	Part No.	Part Description	Qty.
1	100670	3/8-16 x 1 1/4 CARRIAGE BOLT	22
2	113415P	STRINGER WELDMENT 15/20kW MAXI II	1
3	115243	RETAINER PUSH ON	1
4	044004	#6-32 KEPS HEX NUT	4
5	045216	1/4-20 TINNEMAN NUT	1
6	109871P	RADIATOR CAP ACCESS PANEL	1
7	041259	#6-32 x 1/2 PH-FLAT HEAD MACHINE SCREW	4
8	045023	HINGE CONTROLLER COVER	1
9	044029	3/8-16 SERRATED FLANGE NUT	22
10	100859	7/8 ID x 1 1/4 OD GROMMET	1
11	115259	SEAL 1/8 x 1/2 x 9.5	1
12	106250P	STANDARD MUFFLER HOLE PLATE	1
13	102081	5/16-18 x 3/4 CARRIAGE BOLT	4
14	057006	5/16-18 SERRATED FLANGE NUT	4
15	115244	FAST THREAD KNURLED KNOB	1

2.7 - Front Panels with Standard Air Vent Deflectors

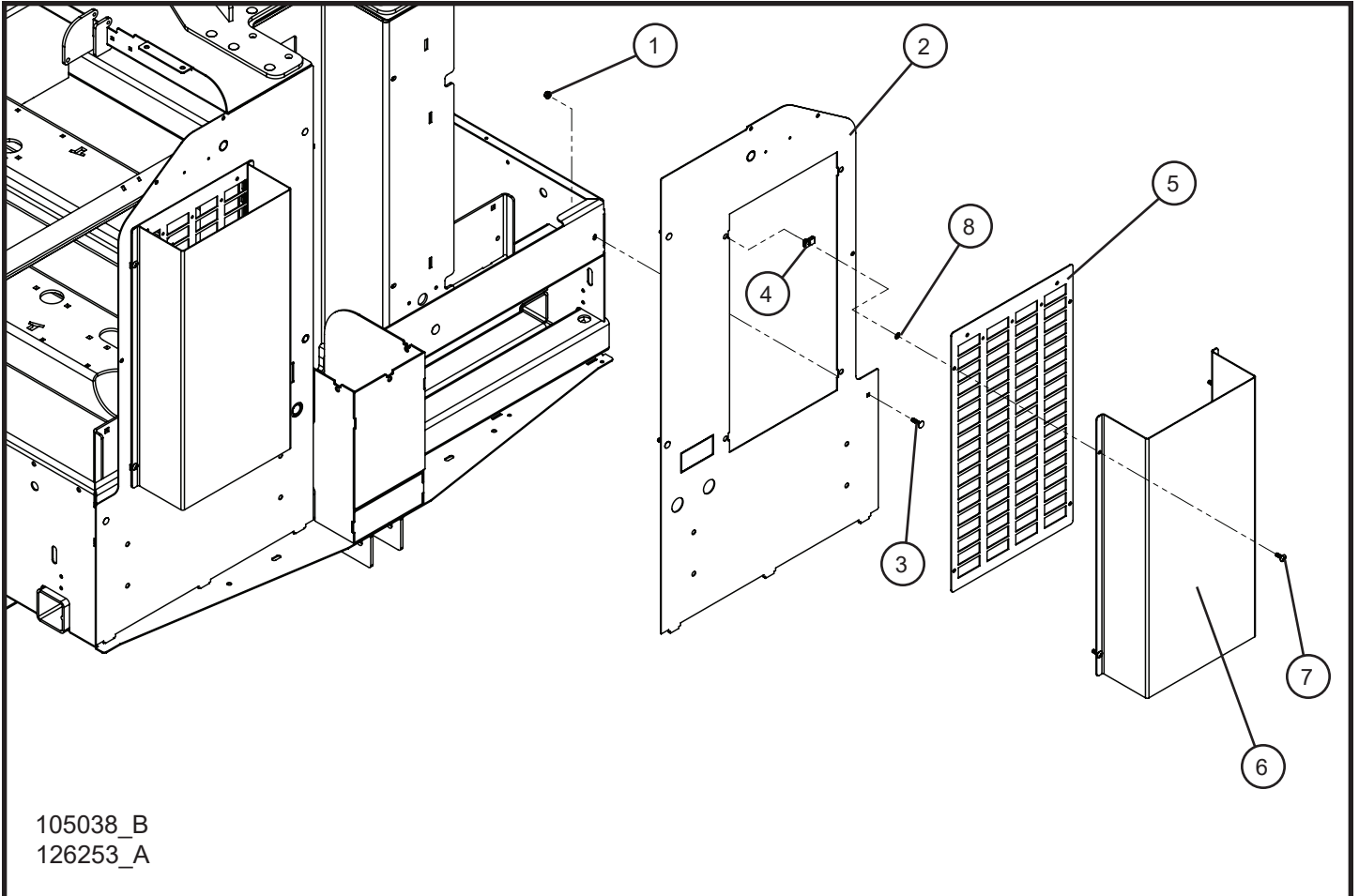

2.7 - Front Panels with Standard Air Vent Deflectors

Item	Part No.	Part Description	Qty.
1	057001	1/4-20 HEX NYLOCK FLANGE NUT	6
2	115139P	MULTI OPTION FRONT PANEL MAXI II	2
	115139HD	MULTI OPTION FRONT PANEL MAXI II - HD POWDER COAT	2
3	100342	1/4-20 x 1 CARRIAGE BOLT	6
4	044106	1/4-20 TINNERMAN NUT	8
5	124081P	PLATE AIR VENT GRID MAXI II	2
6	124082P	AIR VENT DEFLECTORS MAXI II	2
	124082HD	AIR VENT DEFLECTORS MAXI II - HD POWDER COAT	2
7	041050	1/4-20 x 3/4 PH-TRUSS HEAD MACHINE SCREW	8
8	101701	1/4 PUSH NUT	8

2.8 - Front Panels with Optional Air Vent Covers

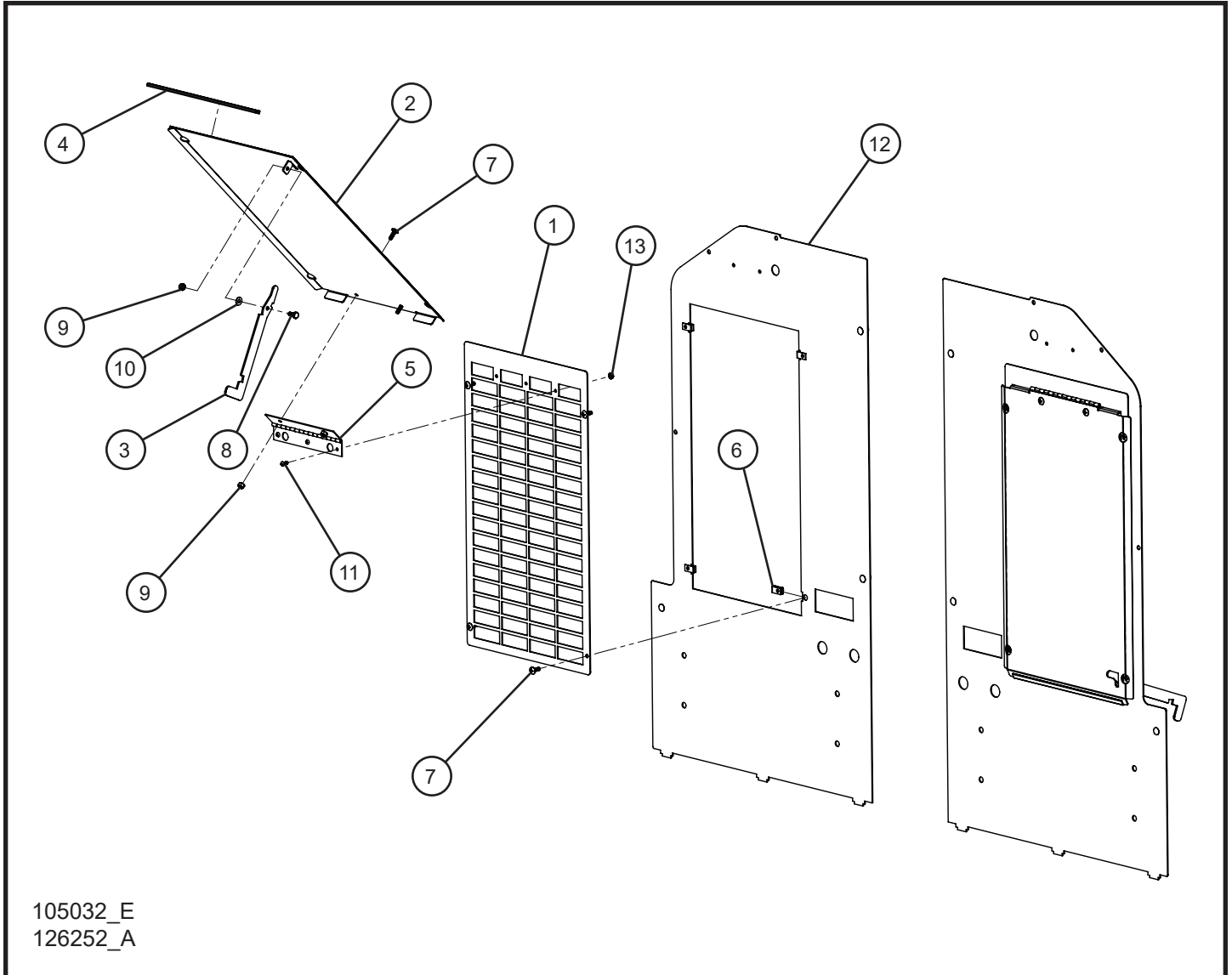

2.8 - Front Panels with Optional Air Vent Covers

Item	Part No.	Part Description	Qty.
1	124081P	PLATE AIR VENT GRID MAXI II	2
2	105001P	SOLID COVER DOOR AIR INLET MAXI II	2
	105001HD	SOLID COVER DOOR AIR INLET MAXI II - HD POWDER COAT	2
3	105029P	LOCK PLATE SOLID COVER	2
4	030053	5/64 x 7/16 TRIM LOCK 12 INCH	2
5	105028	COVER HINGE AIR INTAKE	2
6	044106	1/4-20 TINNERMAN NUT	8
7	041050	1/4-20 x 3/4 PH-TRUSS HEAD MACHINE SCREW	8
8	046006	1/4-20 x 5/8 HEX HEAD BOLT	2
9	044023	1/4-20 NYLOCK HEX NUT	6
10	047009	1/4 FLAT WASHER	2
11	041021	#10-24 x 1/2 PH-ROUND HEAD MACHINE SCREW	6
12	115139P	MULTI OPTION FRONT PANEL MAXI II	2
	115139HD	MULTI OPTION FRONT PANEL MAXI II - HD POWDER COAT	2
13	044016	#10-24 KEPS HEX NUT	6

2.9 - Front Panels Wheel Chock Blocks Option

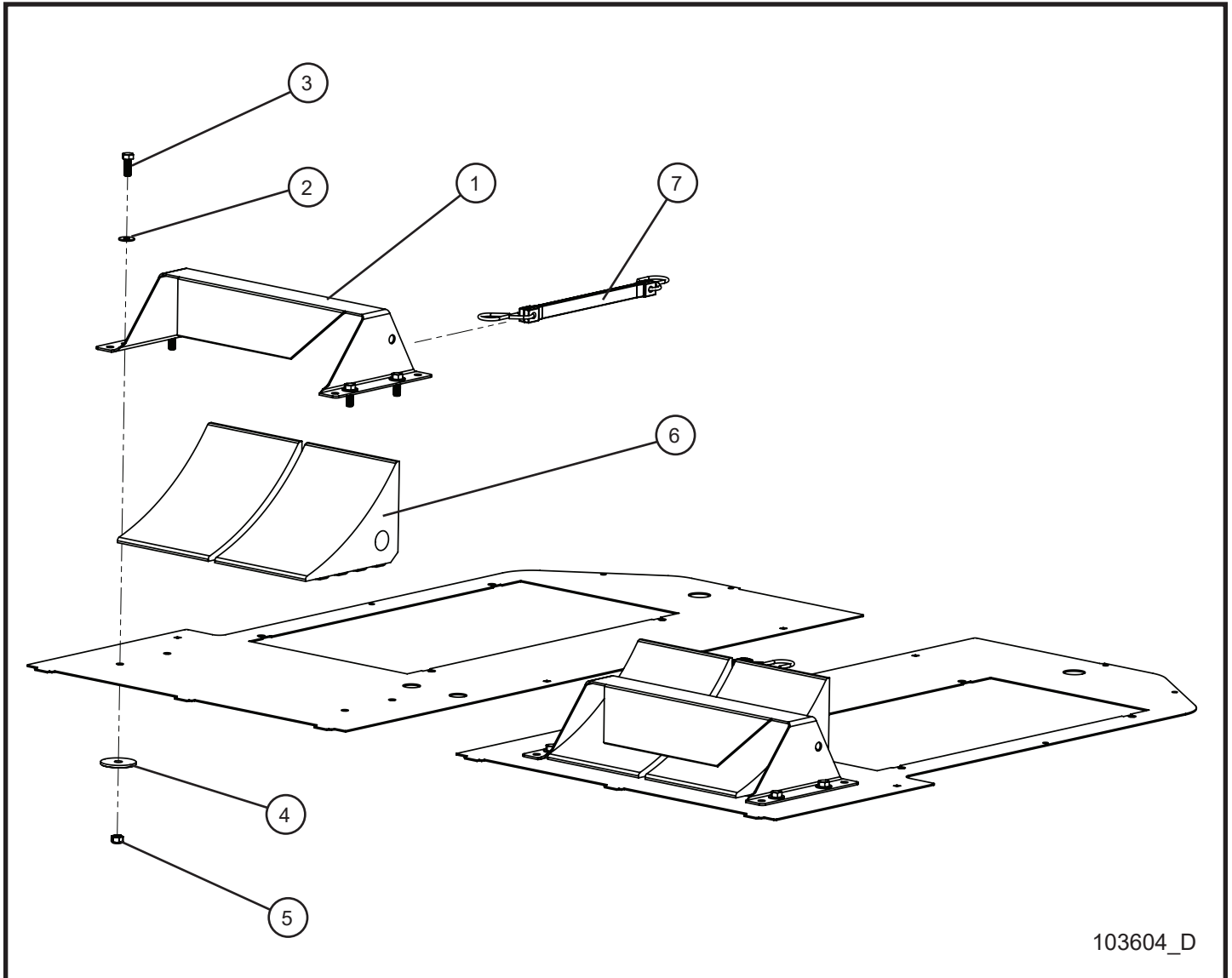

103604_D

2.9 - Front Panels Wheel Chock Blocks Option

Item	Part No.	Part Description	Qty.
1	103621P	BRACKET WHEEL CHOCK (SPECIFY CHIP RESISTANT)	2
2	047010	5/16 FLAT WASHER	8
3	046110	3/8-16 x 1 HEX HEAD BOLT	8
4	650260	WASHER 2 OD x .451 ID x .125	8
5	044038	3/8-16 NYLOCK HEX NUT	8
6	104031	WHEEL CHOCK	4
7	103625	STRAP RUBBER 14"	2

2.10 - Quarter Panels

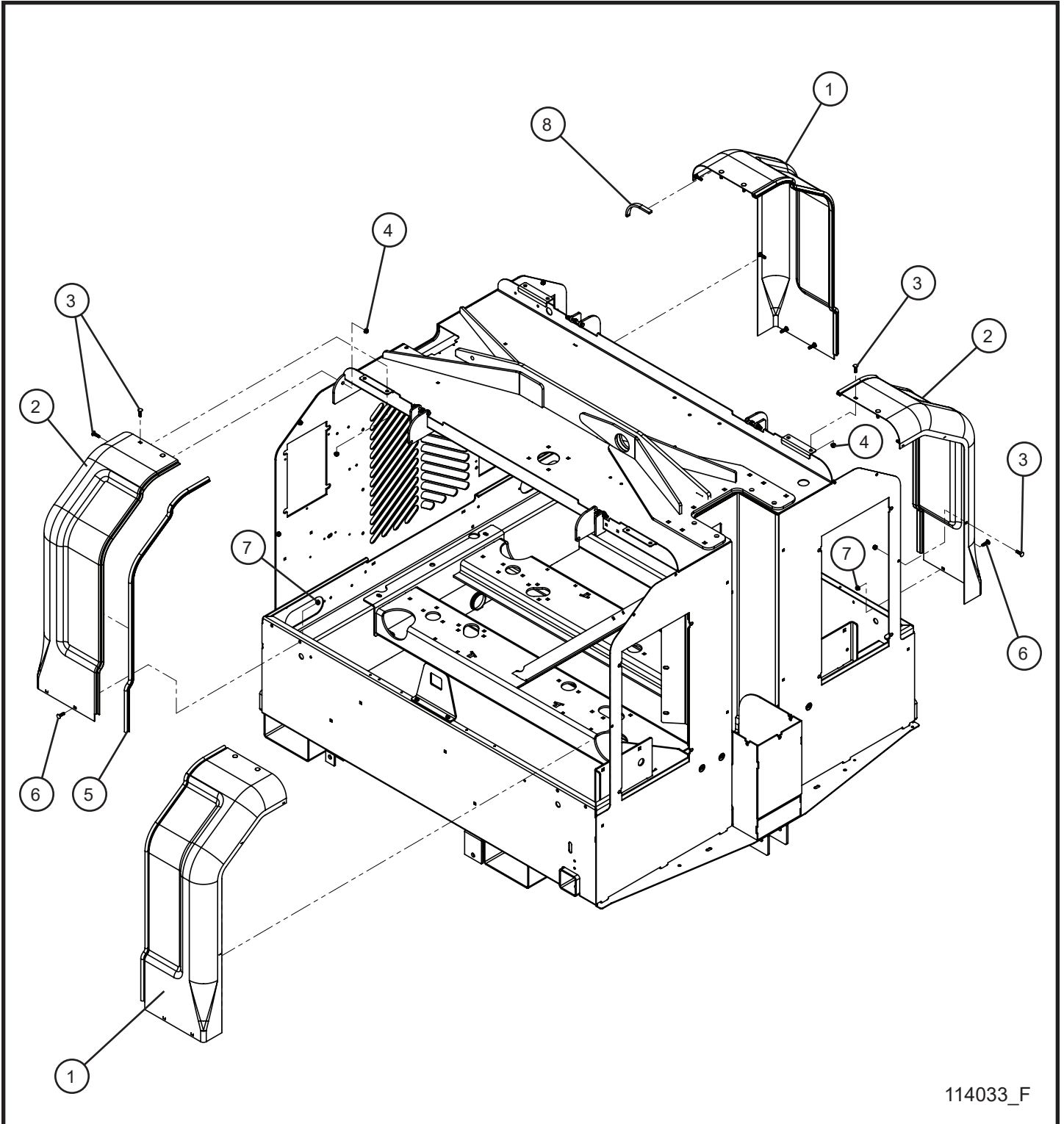

114033_F

2.10 - Quarter Panels

Item	Part No.	Part Description	Qty.
1	103642P	PANEL QUARTER LEFT REAR/RIGHT FRONT	2
2	103643P	PANEL QUARTER LEFT FRONT/RIGHT REAR	2
3	046036	1/4-20 x 1 CARRIAGE BOLT	20
4	057001	1/4-20 HEX NYLOCK FLANGE NUT	20
5	105998	TRIM GASKET 1/16" x 41" WITH 3/8 BULB	4
6	056019	1/4-20 X 3/4 HEX FLANGE SCREW	8
7	057000	1/4-20 HEX SERRATED FLANGE NUT	8
8	115260	SEAL 1/4 x 1/2 x 5.5	4

NS - NOT SHOWN

* * * - CONTACT ALLMAND FOR MORE INFORMATION

2.11 - Doors

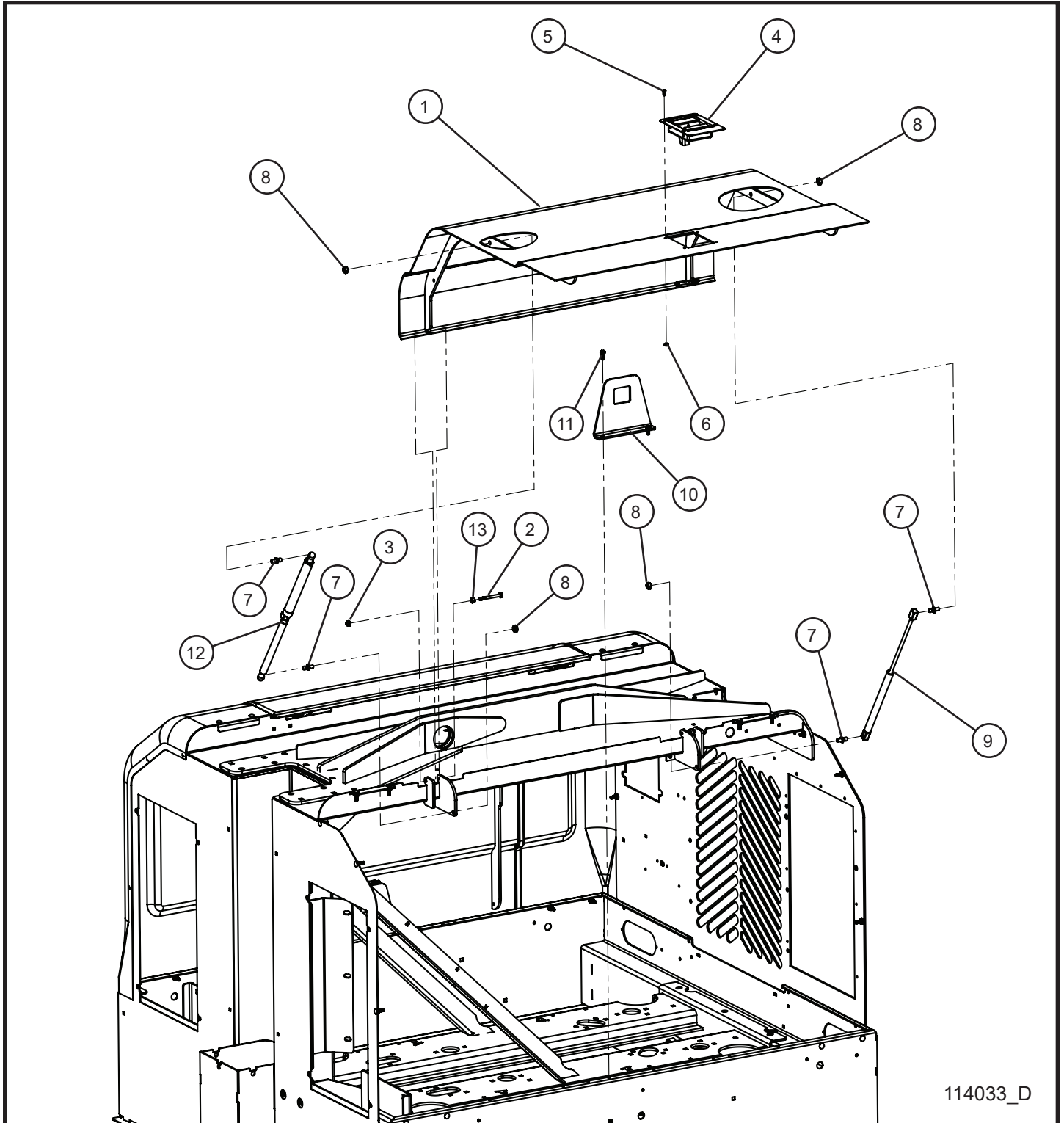

114033_D

2.11 - Doors

Item	Part No.	Part Description	Qty.
1	104540P	MAXI II DOOR	2
2	046036	1/4-20 x 2 1/2 HEX HEAD BOLT	4
3	057001	1/4-20 HEX NYLOCK FLANGE NUT	32
4	680459	SLAM LATCH	2
5	041021	#10-24 x 1/2 PH-ROUND HEAD MACHINE SCREW	8
6	044018	#10-24 NYLOCK HEX NUT	8
7	330437	BALL STUD M10	8
8	044090	5/16-18 TOP LOCK HEX NUT	8
9	680813	LIFT SUPPORT	2
10	104313P	BRACKET DOOR SLAM LATCH	2
11	041070	1/4-20 x 3/4 SL-HEX WASHER HEAD MACHINE SCREW	4
12	105245	CYLINDER GAS SPRING LOCKING	2
13	105362	COLLAR LOCKING .25 ID	4

2.12 - Manual Canister

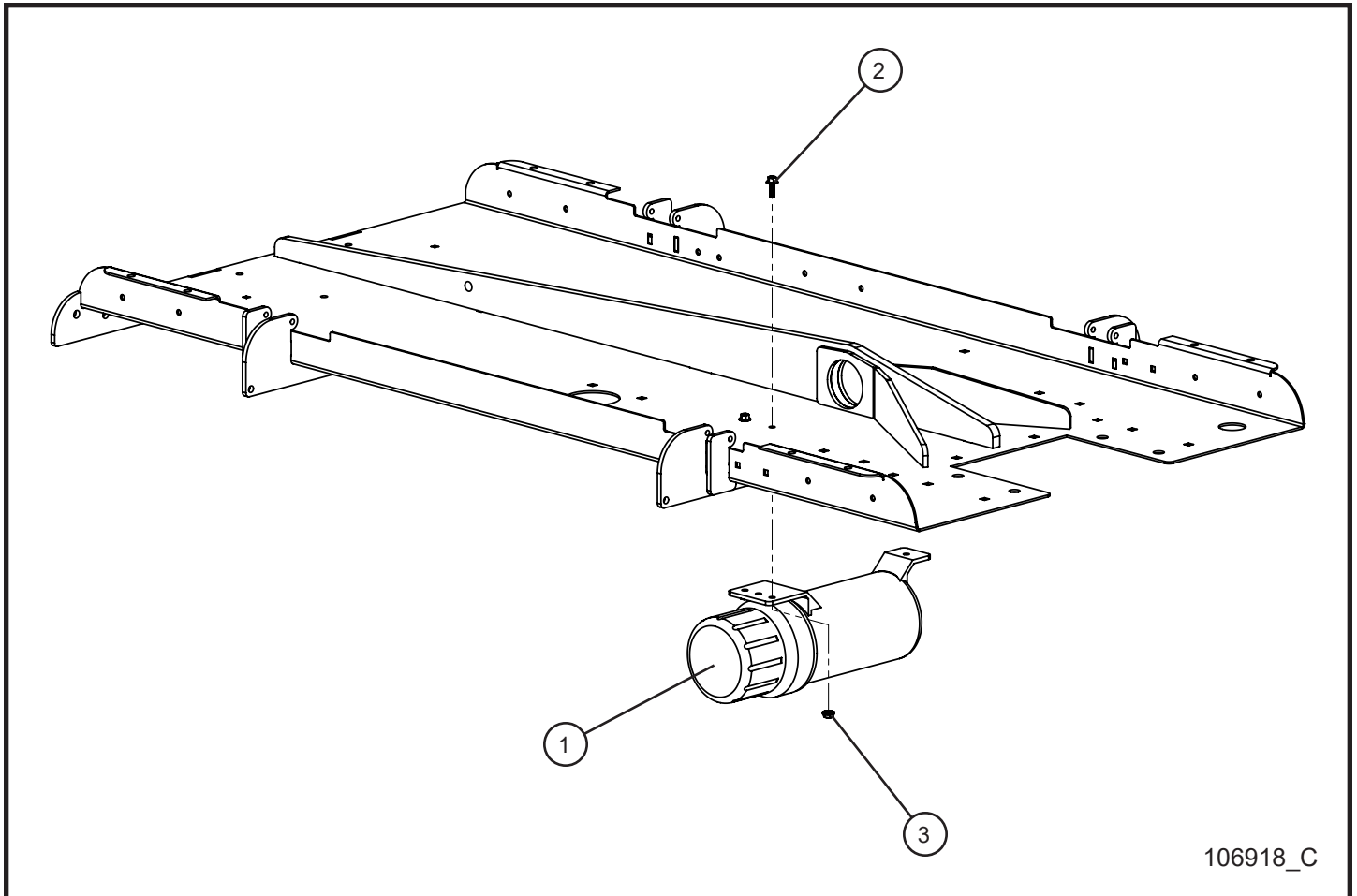

106918_C

2.12 - Manual Canister

Item	Part No.	Part Description	Qty.
1	106916	MEGA CANISTER	1
2	056002	1/4-20 x 3/4 HEX SERRATED FLANGE SCREW	3
3	057000	1/4-20 HEX SERRATED FLANGE NUT	3
NS	122018	DSE L401 MKII CONTROLLER OPERATOR MANUAL	1
NS	114005	OPERATOR'S MANUAL MAXI-LITE	1

3.1 - Vertical Tower Section 1

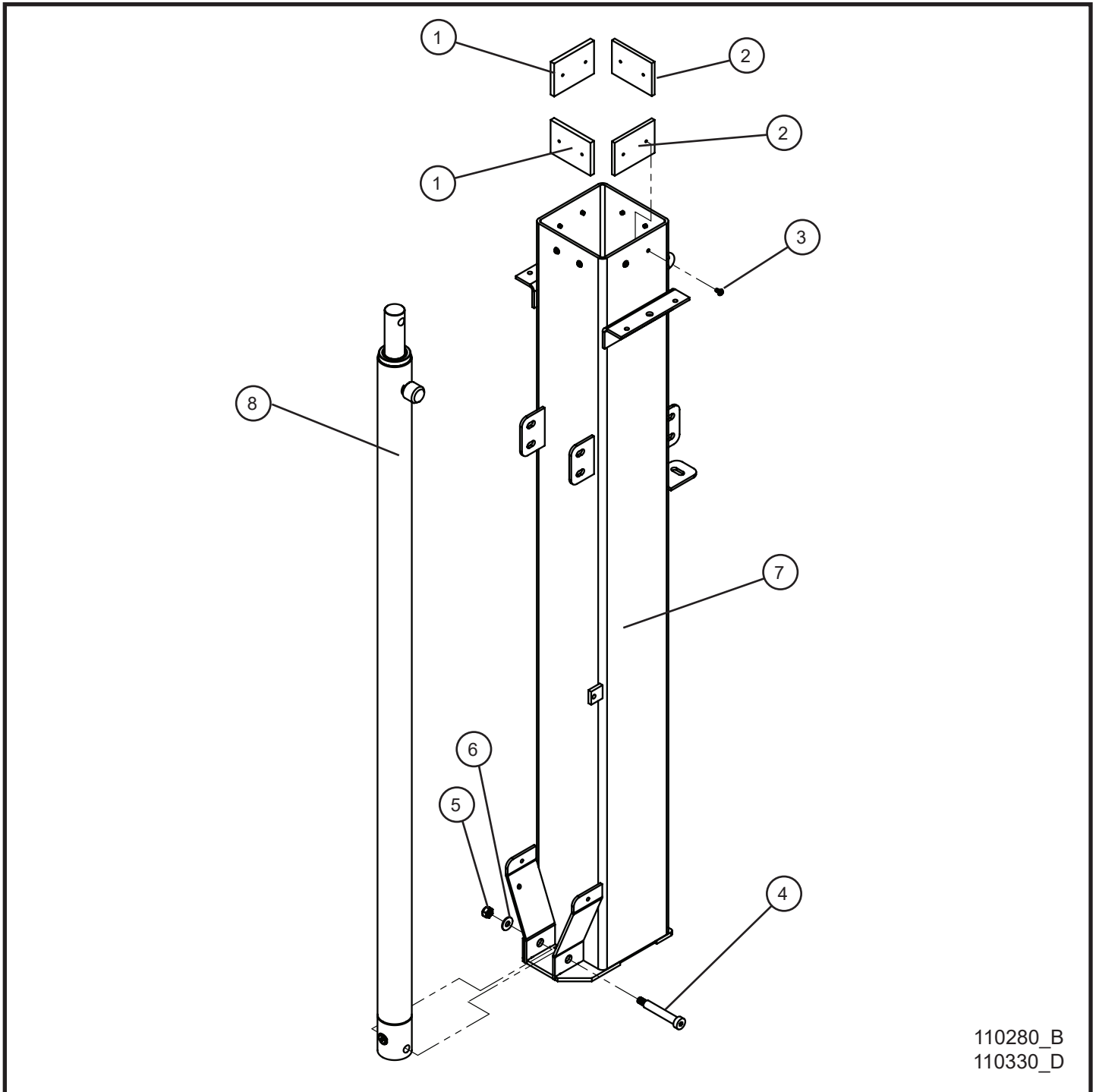

110280_B
110330_D

3.1 - Vertical Tower Section 1

Item	Part No.	Part Description	Qty.
1	650110	.312 TOWER PAD	2
2	102954	.250 TOWER PAD	2
3	041023	#10 x 3/8 PH-ROUND HEAD MACHINE SCREW	8
4	101379	1/2 x 2 3/4 (3/8-16 x 5/8) HX-SOCKET HEAD SHOULDER BOLT	1
5	047010	5/16 FLAT WASHER	1
6	044038	3/8-16 NYLOCK HEX NUT	1
7	110282P	6" VERTICAL TOWER SECTION	1
	113090	6" GALVANIZED VERTICAL TOWER SECTION	1
8	106140	VERTICAL TOWER HYDRAULIC CYLINDER	1

3.2 - Vertical Tower Section 2

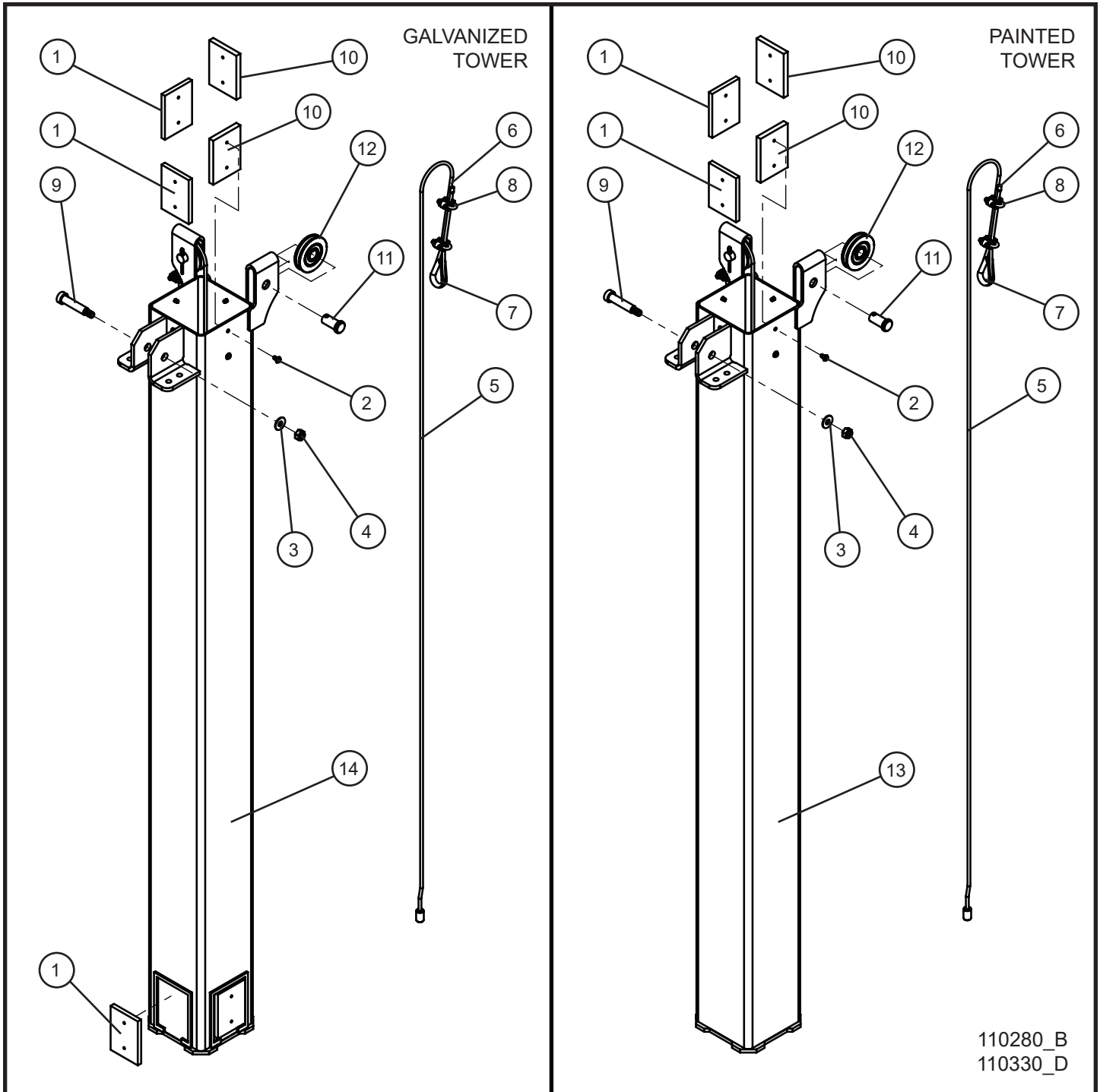

3.2 - Vertical Tower Section 2

Item	Part No.	Part Description	Qty.
1	650110	.312 TOWER PAD	6
2	041023	#10 x 3/8 PH-ROUND HEAD MS PL	8
3	047010	5/16 FLAT WASHER PL	1
4	044038	3/8-16 NYLOCK HEX NUT PL	1
5	320185	STEEL CABLE 3/16 x 10'	2
6	022150	FERRULE 10-12 AWG	2
7	045040	3/16 CABLE THIMBLE 3/16 WIRE ROPE	2
8	620084	3/16 CABLE CLIP	4
9	101378	1/2 x 2 (3/8-16 x 5/8) HX-SOCKET HEAD SHOULDER BOLT	1
10	650109	.375 TOWER PAD	2
11	033000	5/8 x 1 SLIC PIN	5
12	100160	2 1/2 PULLEY BALL BEARING	5
13	110281P	5" VERTICAL TOWER SECTION	1
14	113092	5" GALVANIZED VERTICAL TOWER SECTION	1
NS	045042	COTTER PIN 1/8 X 1 1/2"	2

3.3 - Vertical Tower Section 3

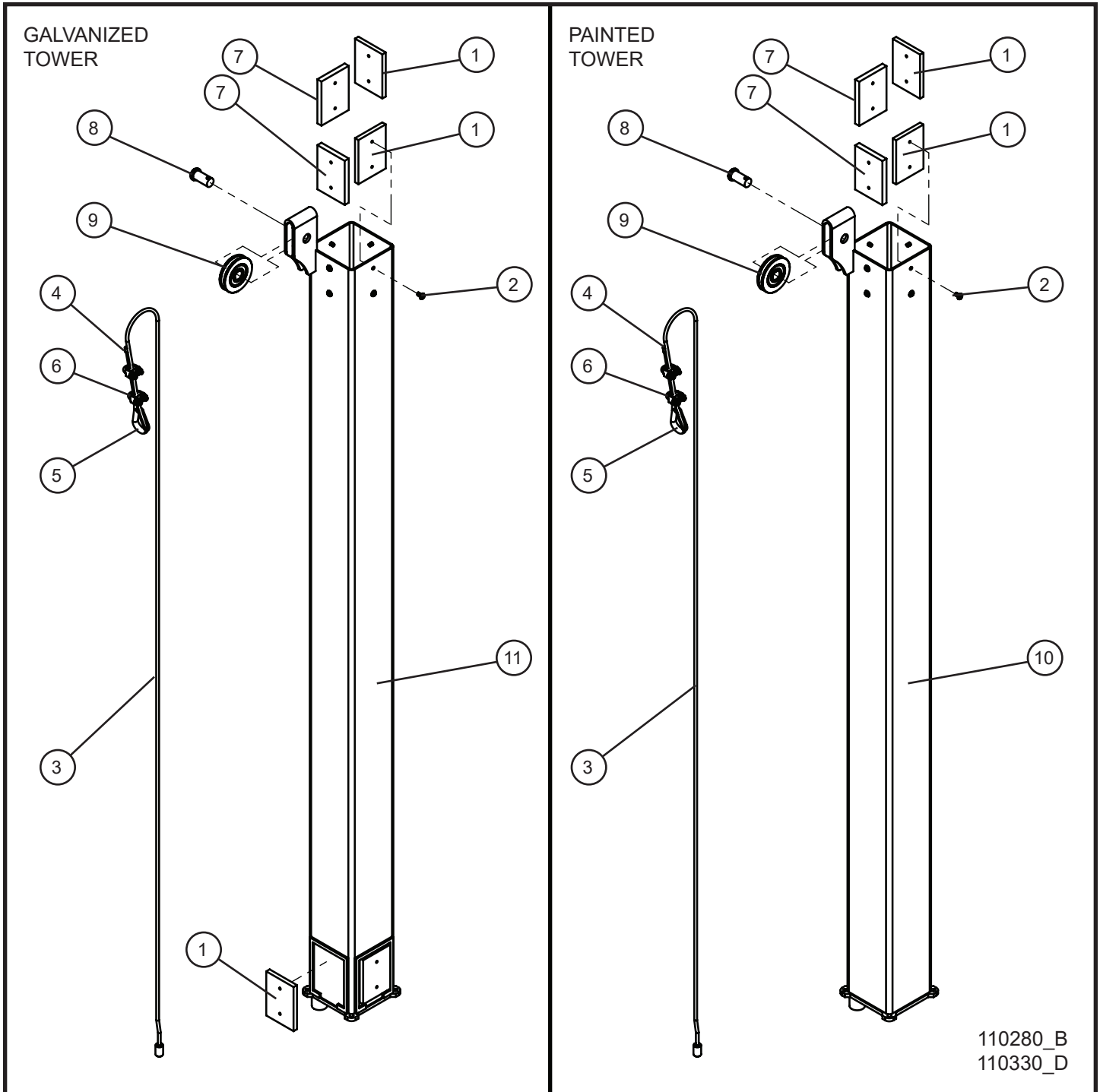

3.3 - Vertical Tower Section 3

Item	Part No.	Part Description	Qty.
1	650110	.312 TOWER PAD	6
2	041023	#10 x 3/8 PH-ROUND HEAD MS PL	8
3	320185	STEEL CABLE 3/16 x 10'	1
4	022150	FERRULE 10-12 AWG	1
5	045040	3/16 CABLE THIMBLE 3/16 WIRE ROPE	1
6	620084	3/16 CABLE CLIP	2
7	650109	.375 TOWER PAD	4
8	033000	5/8 x 1 SLIC PIN	5
9	100160	2 1/2 PULLEY BALL BEARING	5
10	102961P	4" VERTICAL TOWER SECTION	1
11	113093	4" GALVANIZED VERTICAL TOWER SECTION	1
NS	045042	COTTER PIN 1/8 X 1 1/2"	1

3.4 - Vertical Tower Section 4

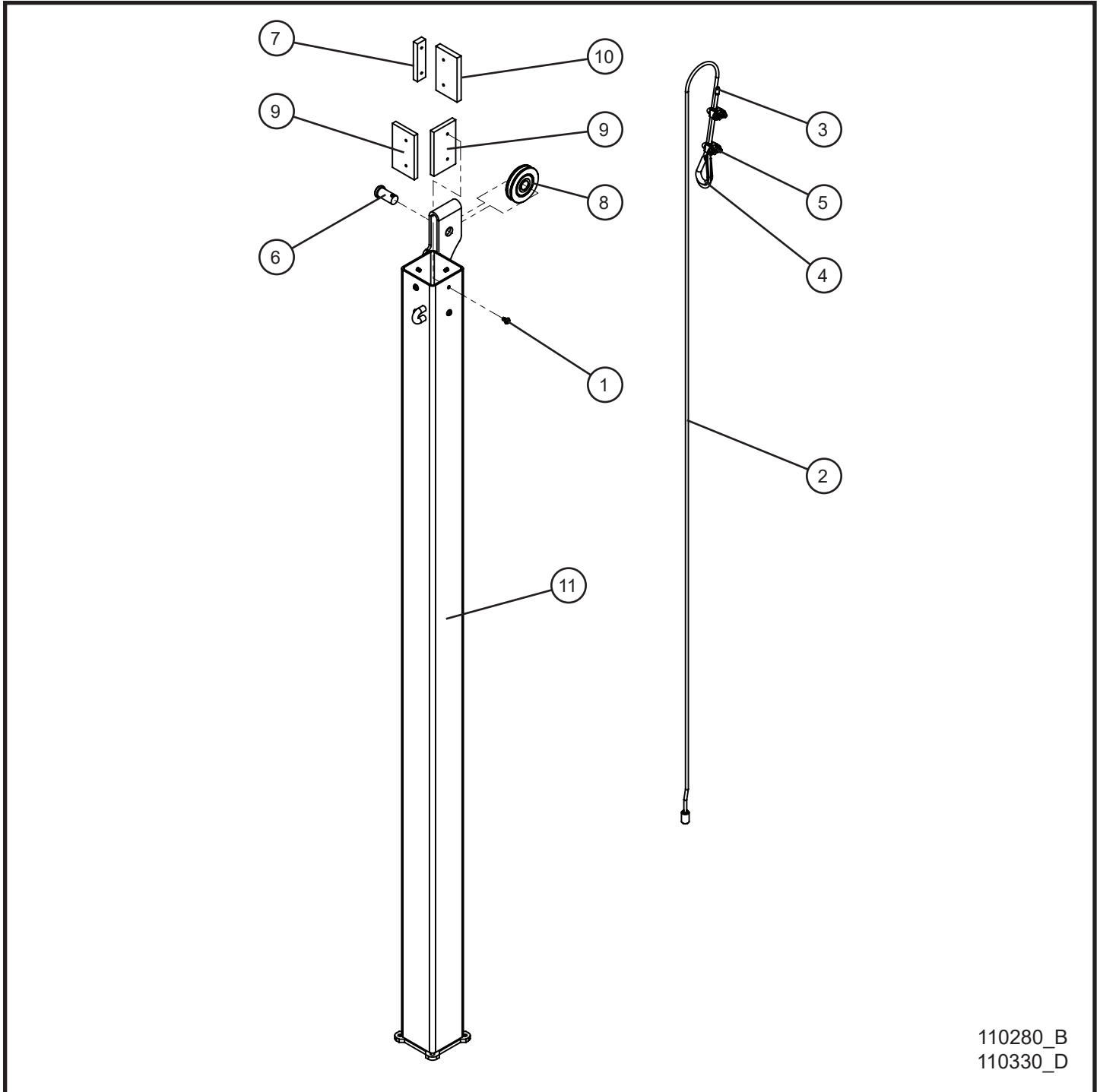

110280_B
110330_D

3.4 - Vertical Tower Section 4

Item	Part No.	Part Description	Qty.
1	041023	#10 x 3/8 PH-ROUND HEAD MS PL	8
2	320185	STEEL CABLE 3/16 x 10'	1
3	022150	FERRULE 10-12 AWG	1
4	045040	3/16 CABLE THIMBLE 3/16 WIRE ROPE	1
5	620084	3/16 CABLE CLIP	2
6	033000	5/8 x 1 SLIC PIN	1
7	100062	3/8 UHMW SPACER	1
8	100160	2 1/2 PULLEY BALL BEARING	1
9	352280	PLASTIC TOWER PAD	2
10	100446	3/8 PAD SMALL	1
11	112727P	3" VERTICAL TOWER SECTION	1
	113094	3" GALVANIZED VERTICAL TOWER SECTION	1
NS	045042	COTTER PIN 1/8 X 1 1/2"	1

3.5 - Vertical Tower Section 5

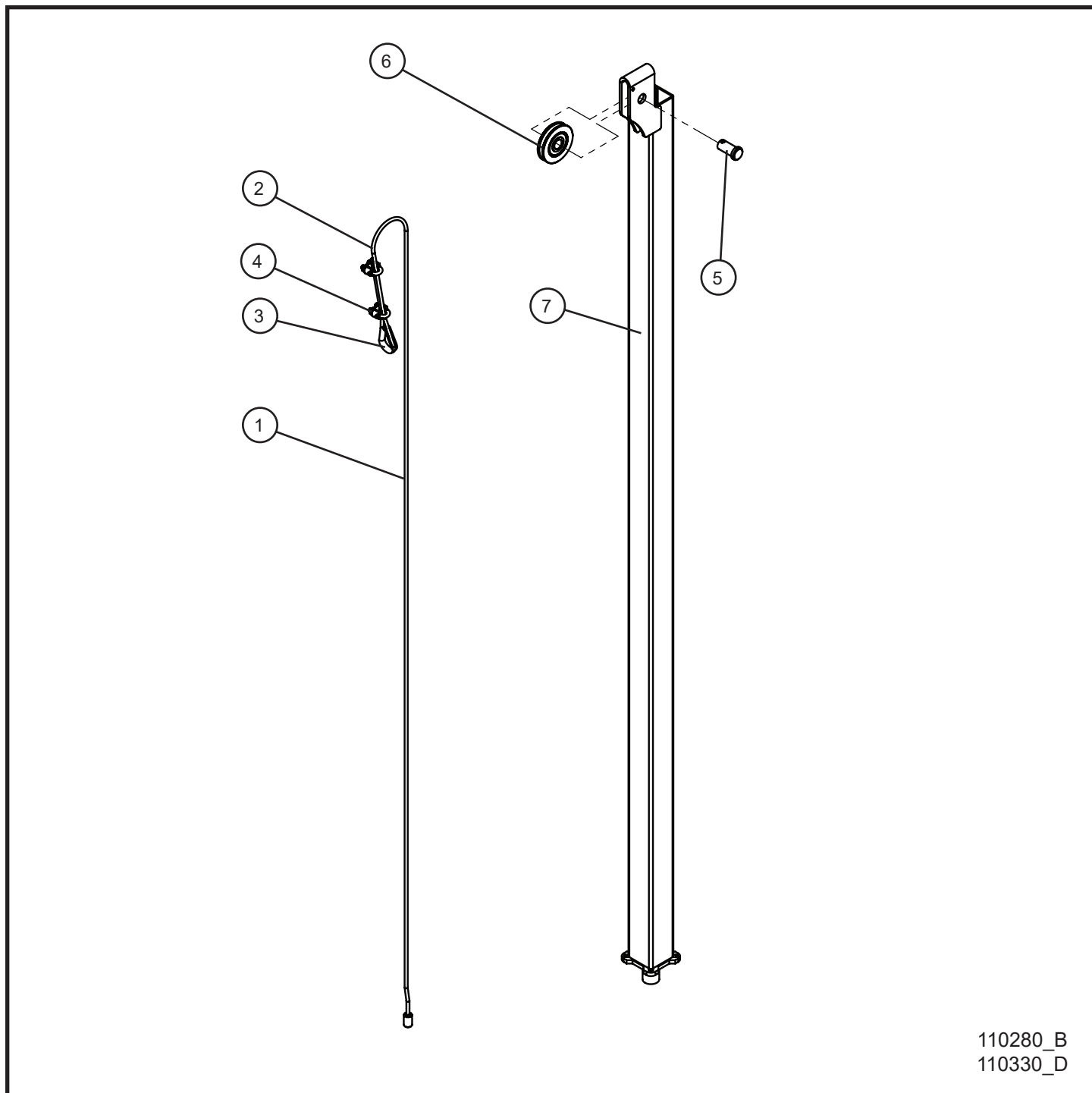

110280_B
110330_D

3.5 - Vertical Tower Section 5

Item	Part No.	Part Description	Qty.
1	320185	STEEL CABLE 3/16 x 10'	1
2	022150	FERRULE 10-12 AWG	1
3	045040	3/16 CABLE THIMBLE 3/16 WIRE ROPE	1
4	620084	3/16 CABLE CLIP	2
5	033000	5/8 x 1 SLIC PIN	1
6	100160	2 1/2 PULLEY BALL BEARING	1
7	102968P	2" VERTICAL TOWER SECTION	1
	113099	2" GALVANIZED VERTICAL TOWER SECTION	1
NS	045042	COTTER PIN 1/8 X 1 1/2"	1

3.6 - Vertical Tower Section 4-Light Round and Light Bar

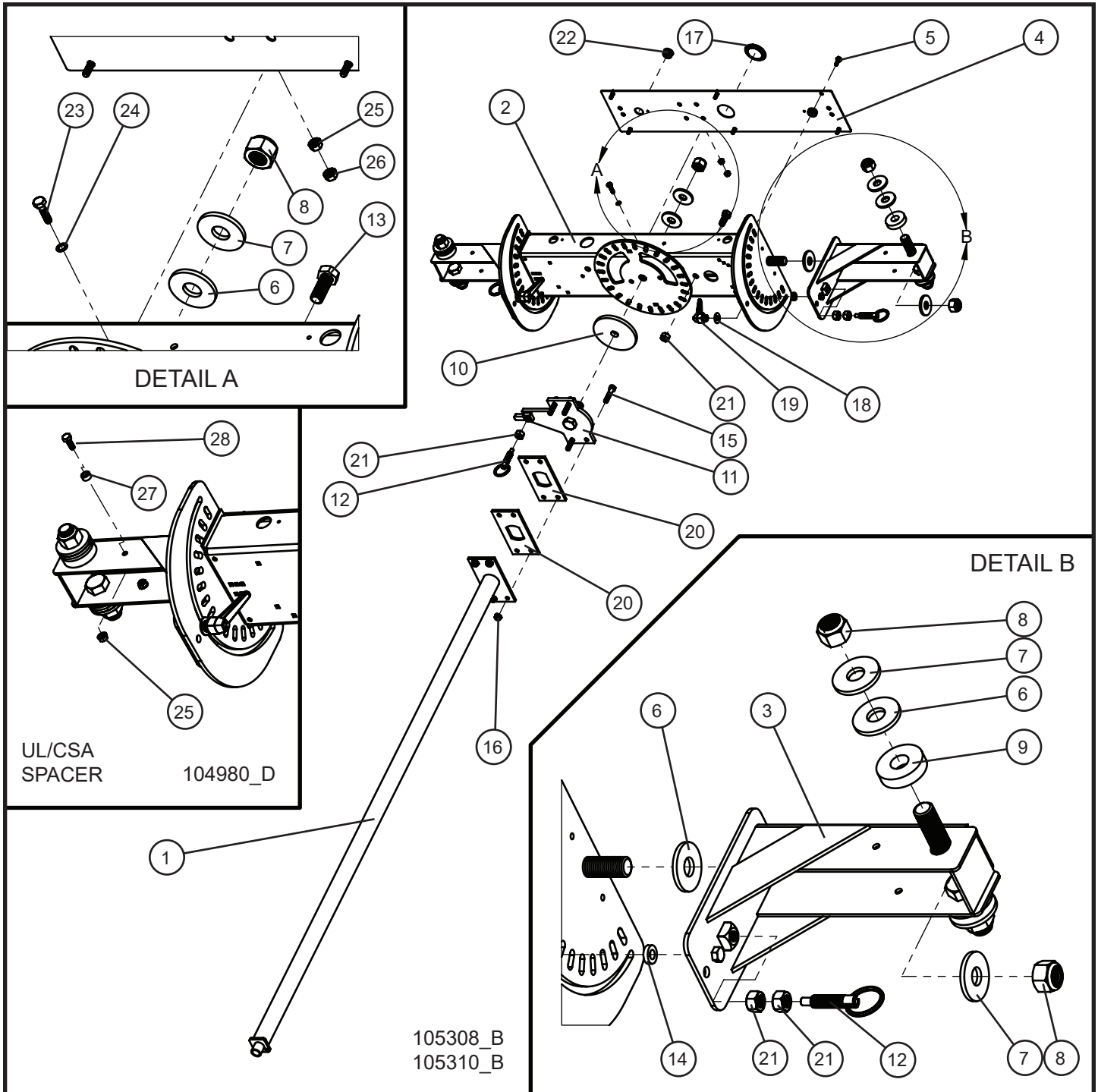

3.6 - Vertical Tower Section 4-Light Round and Light Bar

Item	Part No.	Part Description	Qty.
1	102972P	ROUND TOWER SECTION	1
	113104	ROUND GALVANIZED TOWER SECTION	1
2	105716P	VERTICAL LIGHT BAR WELDMENT	1
	114204P	VERTICAL LIGHT BAR WELDMENT NO CORD REEL	1
3	105363P	BRACKET LAMP ROTATING INDEXING LIGHT BAR	2
4	104063P	COVER LIGHT BAR	1
5	041070	1/4-20 x 3/4 SL-HEX WASHER HEAD MS TP F	6
6	650550	.785" x 2" HDPE WASHER	7
7	047035	3/4 FLAT WASHER	7
8	044058	3/4-10 NYLOCK HEX NUT PL	7
9	101813	.781 ID x 2 OD x 1/2 HDPE WASHER	4
10	100147	UHMW BEARING TOWER ROTATION	1
11	100143P	ROTATION MOUNT	1
12	100148	SPRING LOCK 1/2-13 UNC x 1.4	3
13	046180	1/2-13 X 1 1/4 HEX HEAD CS GR5 PL	1
14	047019	NYLON BUSHING 3/4 OD x .385 ID	2
15	046126	3/8-16 x 1 3/4 HEX HEAD CS GR5 PL	4
16	044036	3/8-16 KEPS HEX NUT PL	4
17	680878	1 3/4 CAPLUG	1
18	047015	3/8 FLAT WASHER PL	2
19	102361	ADJUSTABLE LEVER PUSH BUTTON	2
20	100104P	LIGHT BAR BRACKET	2
21	044045	1/2-13 HEX NUT PL	6
22	711029	7/8 LOCKING HOLE PLUG	2
23	046010	1/4-20 x 1 HEX HEAD CS GR5 PL	1
24	043050	1/4 INT'L TOOTH LOCK WASHER	1
25	044021	1/4-20 KEPS HEX NUT PL	5
26	044023	1/4-20 NYLOCK HEX NUT PL	1
27	104979	UL/CSA CLEARANCE SPACER NYLON UNTHREADED	4
28	046010	1/4-20 x 3/4 HEX HEAD CS GR5 SS	4

3.7 - Vertical Tower Section 6-Light Round and Light Bar

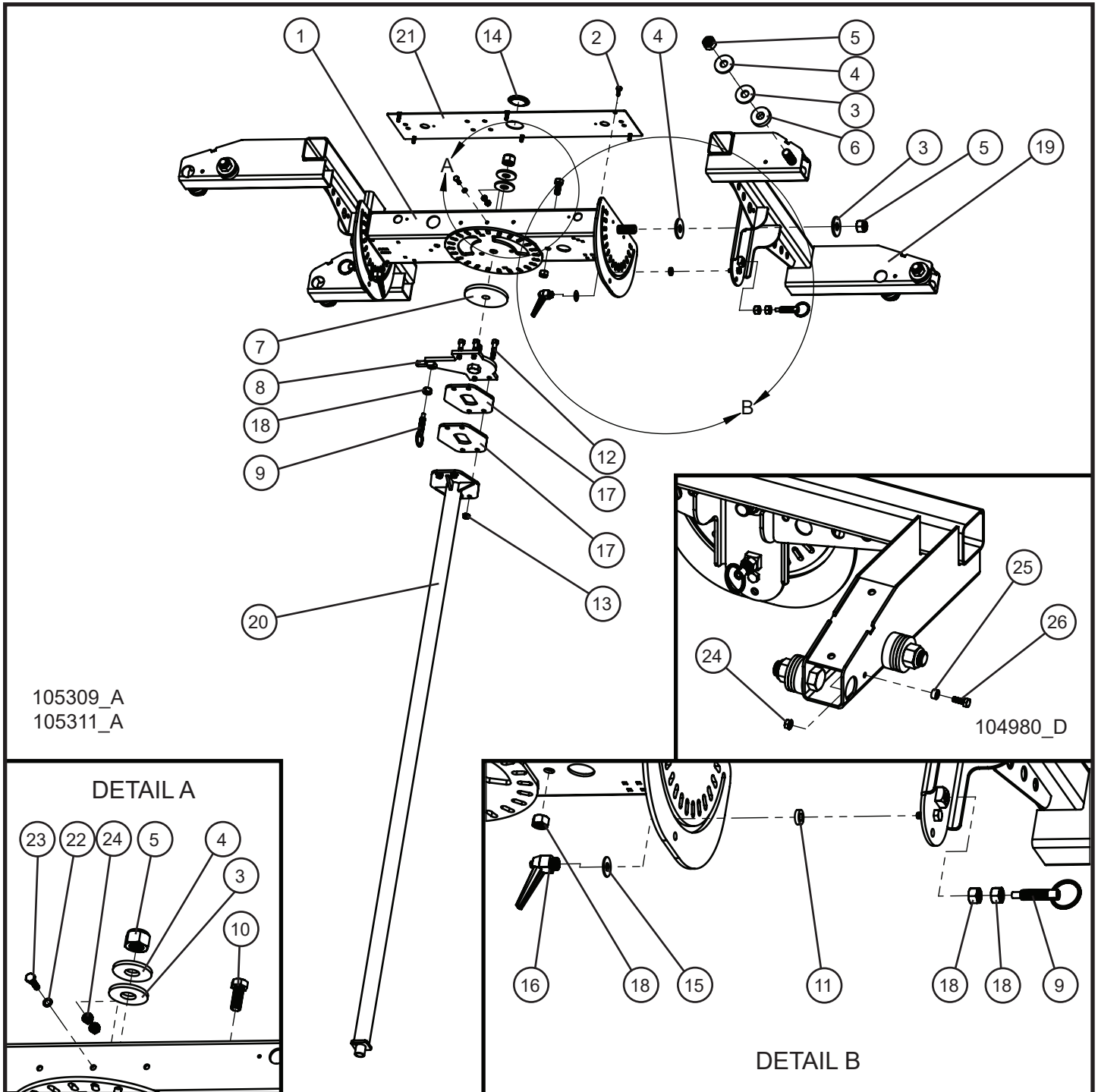

3.7 - Vertical Tower Section 6-Light Round and Light Bar

Item	Part No.	Part Description	Qty.
1	105716P	VERTICAL LIGHT BAR WELDMENT	1
	114204P	VERTICAL LIGHT BAR WELDMENT NO CORD REEL	1
2	041070	1/4-20 x 3/4 SL-HEX WASHER HEAD MS TP F	6
3	650550	.785 x 2 HDPE WASHER	9
4	047035	3/4 FLAT WASHER	9
5	044058	3/4-10 NYLOCK HEX NUT PL	9
6	101813	.781 ID x 2 OD x 1/2 HDPE WASHER	6
7	100147	UHMW BEARING TOWER ROTATION	1
8	100143P	ROTATION MOUNT	1
9	100148	SPRING LOCK 1/2-13 UNC x 1.4	3
10	046180	1/2-13 x 1 1/4 HEX HEAD CS GR5 PL	1
11	047019	NYLON BUSHING 3/4 OD x .385 ID	2
12	046126	3/8-16 x 1 3/4 HEX HEAD CS GR5 PL	4
13	044036	3/8-16 KEPS HEX NUT PL	4
14	680878	1 3/4 CAPLUG	1
15	047015	3/8 FLAT WASHER PL	2
16	102361	ADJUSTABLE LEVER PUSH BUTTON	2
17	105501P	BRACKET LIGHT BAR SPACER	2
18	044045	1/2-13 HEX NUT PL	4
19	104091P	6 LIGHT FIXTURE BRACKET	2
20	104053P	ROUND SECTION OPTION	1
	115096	ROUND SECTION OPTION (GALVANIZED)	1
21	104063P	COVER LIGHT BAR	1
22	043050	1/4 INT'L TOOTH LOCK WASHER	1
23	046015	1/4-20 x 1 HEX HEAD CS GR5 PL	1
24	044021	1/4-20 KEPS HEX NUT PL	8
25	104979	UL/CSA CLEARANCE SPACER NYLON UNTHREADED	6
26	046010	1/4-20 x 3/4 HEX HEAD CS GR5 SS	6

3.8 - Vertical Tower Components (1 of 2)

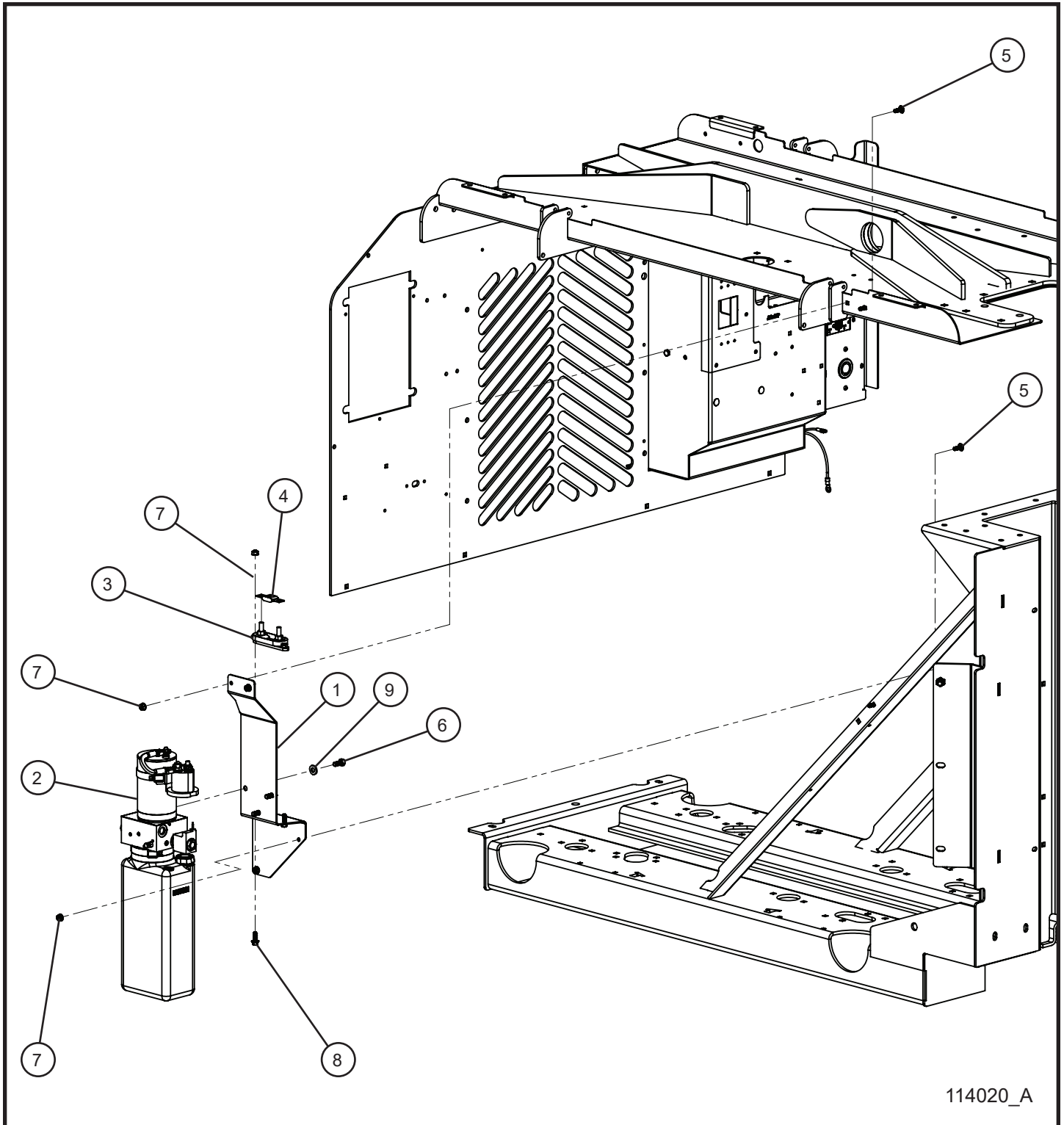

114020_A

3.8 - Vertical Tower Components (1 of 2)

Item	Part No.	Part Description	Qty.
1	104308P	BRACKET MOUNT VERTICAL PUMP	1
2	104358	POWER UNIT VERTICAL TOWER	1
3	100235	FUSE HOLDER F AMG FUSE	1
4	100234	125A FUSE LINK BUSS AMG	1
5	053006	1/4-20 x 3/4 CARRIAGE BOLT	4
6	046045	5/16-18 x 3/4 HEX HEAD BOLT	3
7	057001	1/4-20 HEX NYLOCK FLANGE NUT	6
8	056002	1/4-20 x 3/4 SERRATED FLANGE HEX SCREW	2
9	043055	5/16 SPLITLOCK WASHER	3
NS	113143	HYDRAULIC VERTICAL KEY SWITCH SCHEMATIC	1

*NS - NOT SHOWN

3.8 - Vertical Tower Components (2 of 2)

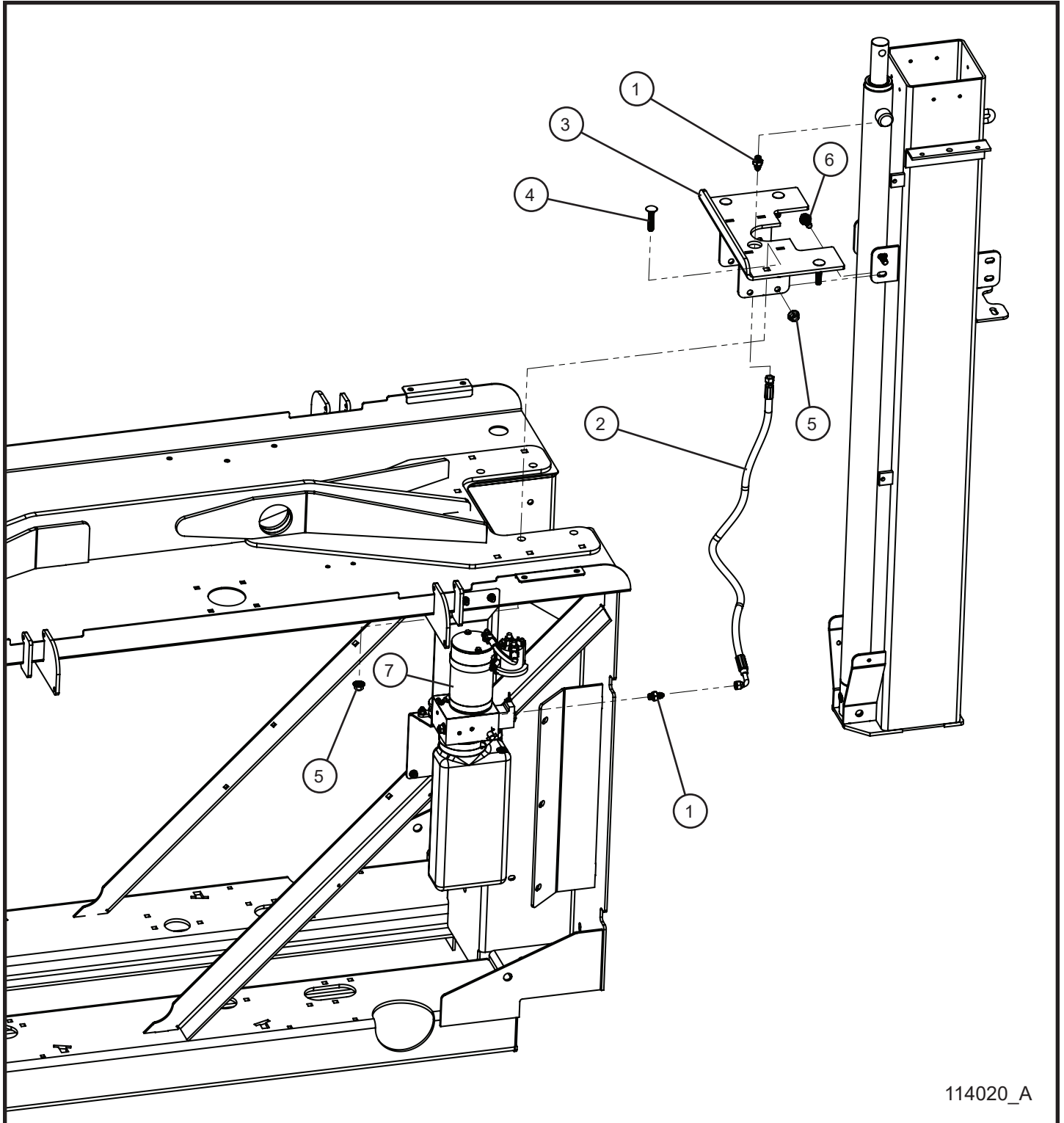

114020_A

3.8 - Vertical Tower Components (2 of 2)

Item	Part No.	Part Description	Qty.
1	923205	STRAIGHT ADAPTER	2
2	101910	HYDRAULIC HOSE	1
3	114014P	VERTICAL TOWER WELDMENT MOUNT	1
4	053031	3/8-16 x 1 3/4 CARRIAGE BOLT	4
5	044029	3/8-16 SERRATED FLANGE NUT	8
6	056010	3/8-16 x 1 SERRATED FLANGE HEX SCREW	4
7	104358	POWER UNIT VERTICAL TOWER	1

3.9 - Vertical Tower Standard Front Cover

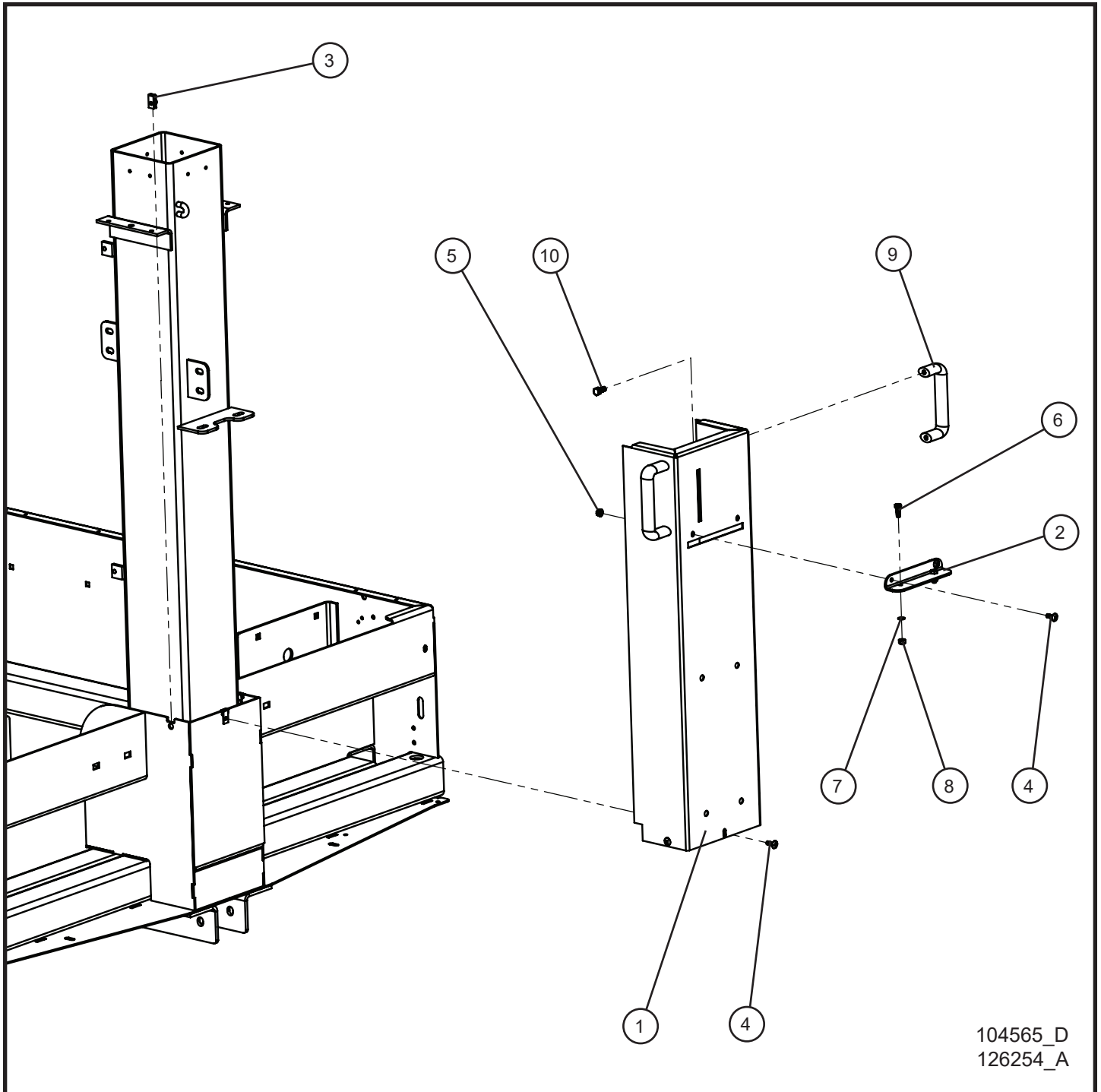

3.9 - Vertical Tower Standard Front Cover

Item	Part No.	Part Description	Qty.
1	104555P	VERTICAL TOWER COVER PANEL	1
	104555HD	VERTICAL TOWER COVER PANEL - HD POWDER COAT	1
2	104299P	HANDLE BRACKET VERTICAL TOWER	1
3	044106	1/4-20 TINNEMAN NUT	3
4	041050	1/4-20 x 3/4 PH-TRUSS HEAD MACHINE SCREW	5
5	044021	1/4-20 KEPS HEX NUT	2
6	046010	1/4-20 x 3/4 HEX HEAD BOLT	2
7	047009	1/4 FLAT WASHER	2
8	044023	1/4-20 NYLOCK HEX NUT	2
9	103887	HANDLE THREE POINT	2
10	056030	5/16-18 X 1/2 HEX FLANGE SCREW	4

3.10 - Vertical Tower Isuzu Front Cover

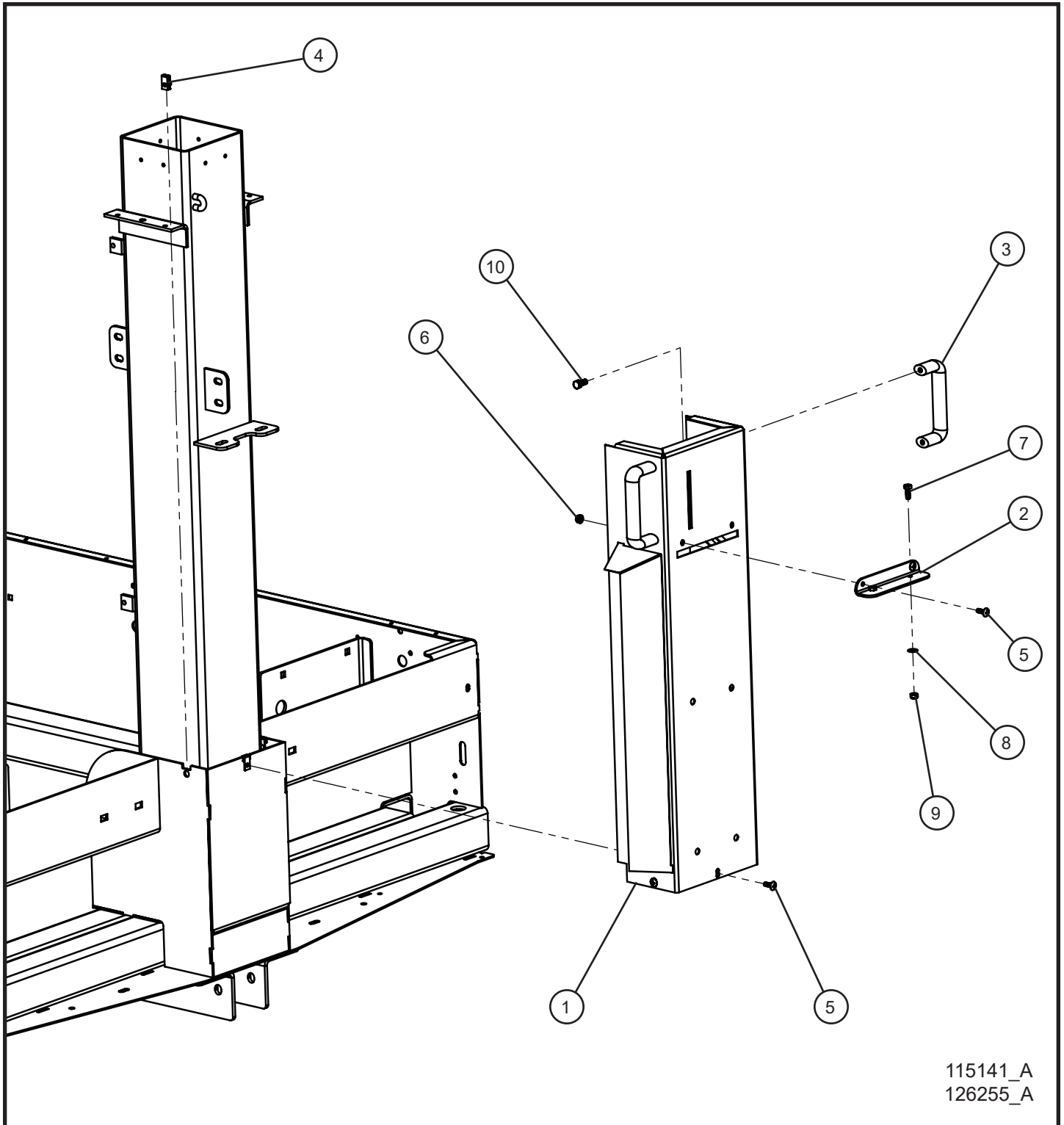

115141_A
126255_A

3.10 - Vertical Tower Isuzu Front Cover

Item	Part No.	Part Description	Qty.
1	107015P	VERT TOWER COVER AIR INLET PANEL	1
	107015HD	VERT TOWER COVER AIR INLET PANEL - HD POWDER COAT	1
2	104299P	HANDLE BRACKET VERTICAL TOWER	1
3	103887	HANDLE THREE POINT	2
4	044106	1/4-20 TINNEMAN NUT	3
5	041050	1/4-20 x 3/4 PH-TRUSS HEAD MACHINE SCREW	5
6	044021	1/4-20 KEPS HEX NUT	2
7	046010	1/4-20 x 3/4 HEX HEAD BOLT	2
8	047009	1/4 FLAT WASHER	2
9	044023	1/4-20 NYLOCK HEX NUT	2
10	056030	5/16-18 X 1/2 HEX FLANGE SCREW	4

3.11 - Vertical Tower 4-Light Nycoil Tower Cord

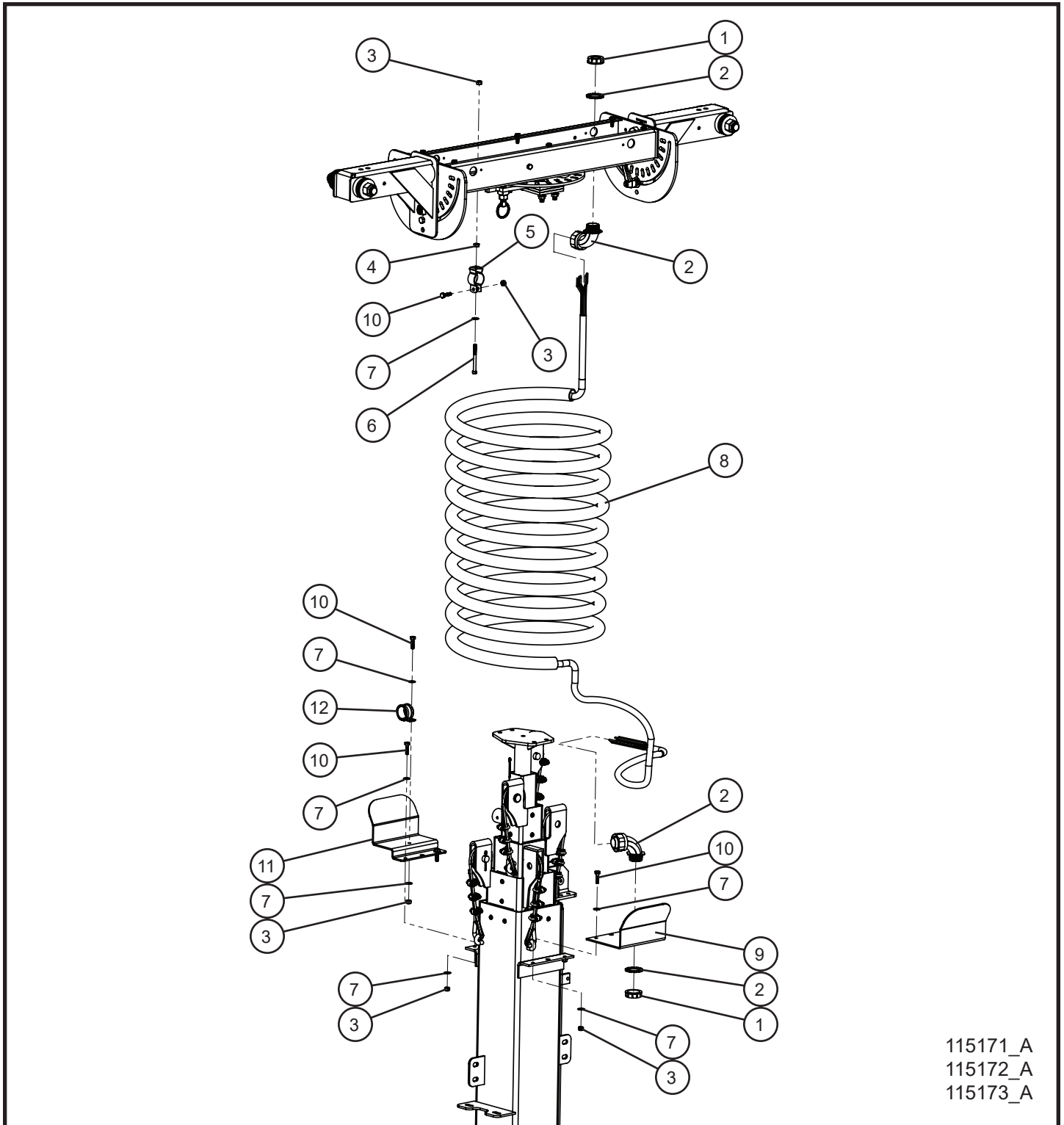

115171_A
115172_A
115173_A

3.11 - Vertical Tower 4-Light Nycoil Tower Cord

Item	Part No.	Part Description	Qty.
1	101672	1" INSULATING BUSHING	2
2	102979	CORD GRIP 90° ELBOW LIQUID TIGHT	2
3	044023	1/4-20 NYLOCK HEX NUT PL	7
4	044021	1/4-20 KEPS HEX NUT PL	1
5	100474	1" CONDUIT CLAMP	1
6	046037	1/4-20 x 2 3/4 HEX HEAD CS GR5 PL	1
7	047009	1/4 FLAT WASHER SAE SS	11
8	120071	MAXI-LITE 16/8 CORD NYCOIL ASSEMBLY (INCL. 2-102979)	1
	120074	MAXI-LITE 16/8 COB LED CORD NYCOIL ASSEMBLY (INCL. 2-102979)	1
9	102977P	CORD GRIP BRACKET	1
10	046015	1/4-20 x 1 HEX HEAD CS GR5 PL	6
11	102978P	NYCOIL CLAMP PLATE	1
12	920366	#16 CUSH CLAMP W/ 3/8 HOLE	1
NS	110106	SCHEMATIC LED LIGHT BAR 4 LIGHT 16/8 CORD	1
NS	105292	SCHEMATIC LIGHT BAR 4 LIGHT 16/8 CORD	1

*NS - NOT SHOWN

3.12 - 4-Light SHO Lamp Junction Box

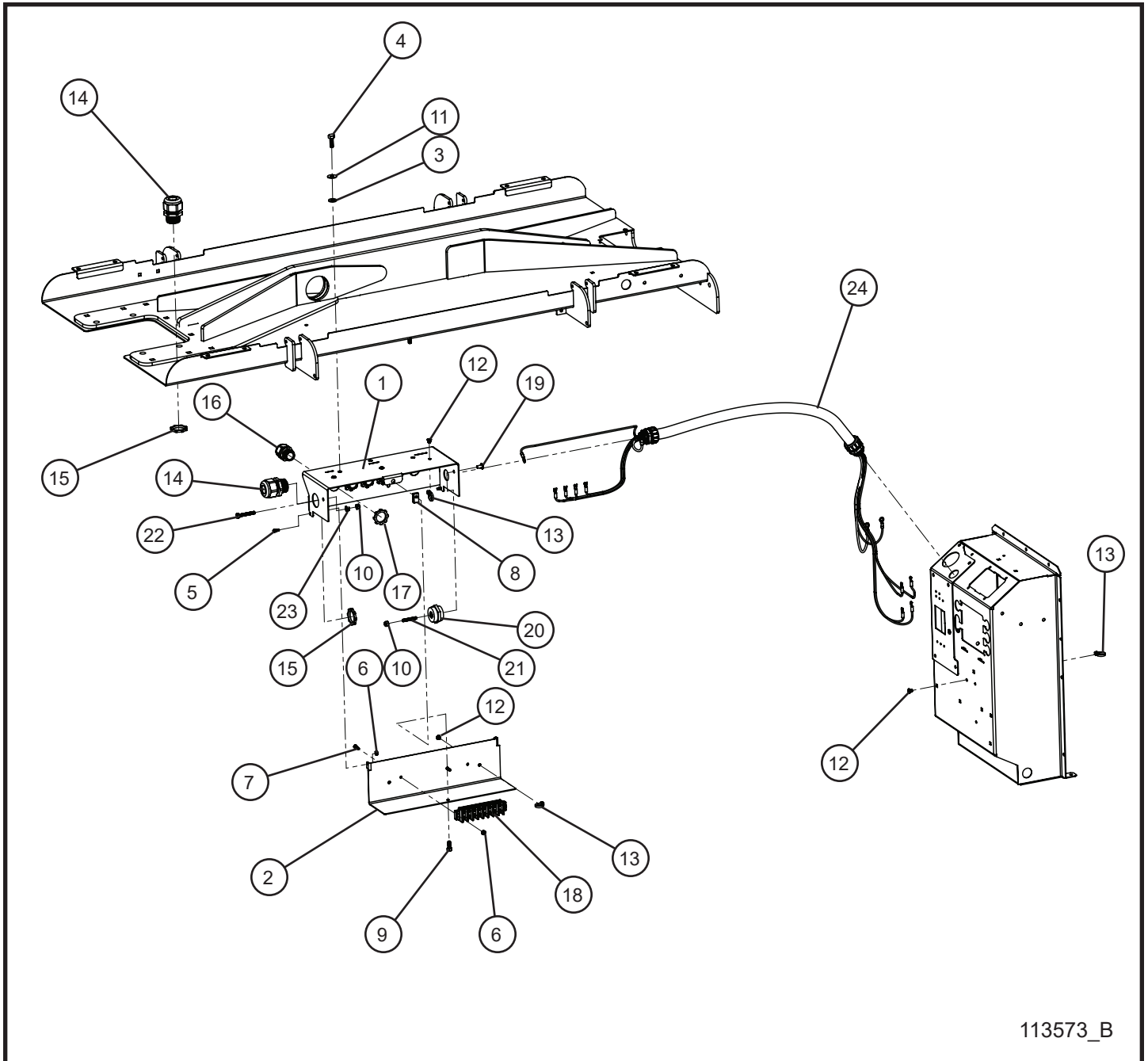

113573_B

3.12 - 4-Light SHO Lamp Junction Box

Item	Part No.	Part Description	Qty.
1	113560P	MAXI-LITE TOP JUNCTION BOX	1
2	112559P	MAXI-LITE BOTTOM JUNCTION BOX	1
3	100644	RUBBER WASHER	3
4	046050	5/16-18 x 1 HEX HEAD BOLT	3
5	041024	#10-24 x 1/2 PH-ROUND HEAD MACHINE SCREW	2
6	044018	#10-24 NYLOCK HEX NUT	4
7	041027	#10-24 x 3/4 PH-ROUND HEAD MACHINE SCREW	2
8	044106	1/4-20 TINNERMAN NUT	3
9	046010	1/4-20 x 3/4 HEX HEAD BOLT	1
10	044023	1/4-20 NYLOCK HEX NUT	2
11	047010	5/16 FLAT WASHER	3
12	022137	PUSH BUTTON	7
13	068090	8" CABLE TIE	8
14	105627	1" CORD GRIP	2
15	022038	1" CORD GRIP NUT	2
16	105916	3/4" CORD GRIP	4
17	022036	3/4" CORD GRIP NUT	4
18	106732	8 GANG SCREW TERMINAL BLOCK	1
19	122452	1/4-20 X 1/2 HEX SERRATED FLANGE BOLT W/ THREAD LOCK	1
20	106318	1-1/4", 1/4-20 LOW VOLTAGE INSULATOR	1
21	122454	1/4-20 X 1-1/2 STUD W/ THREAD LOCK	1
22	046029	1/4-20 x 1 3/4 HEX HEAD BOLT	1
23	044021	1/4-20 KEPS HEX NUT	1
24	113577	MAXI-LITE 4-LIGHT HARNESS CONDUIT	1
NS	113626	MAXI-LITE 4-LIGHT JUNCTION BOX 16/8 CORD SCHEMATIC	1

3.13 - 4-Light COB LED Lamp Junction Box

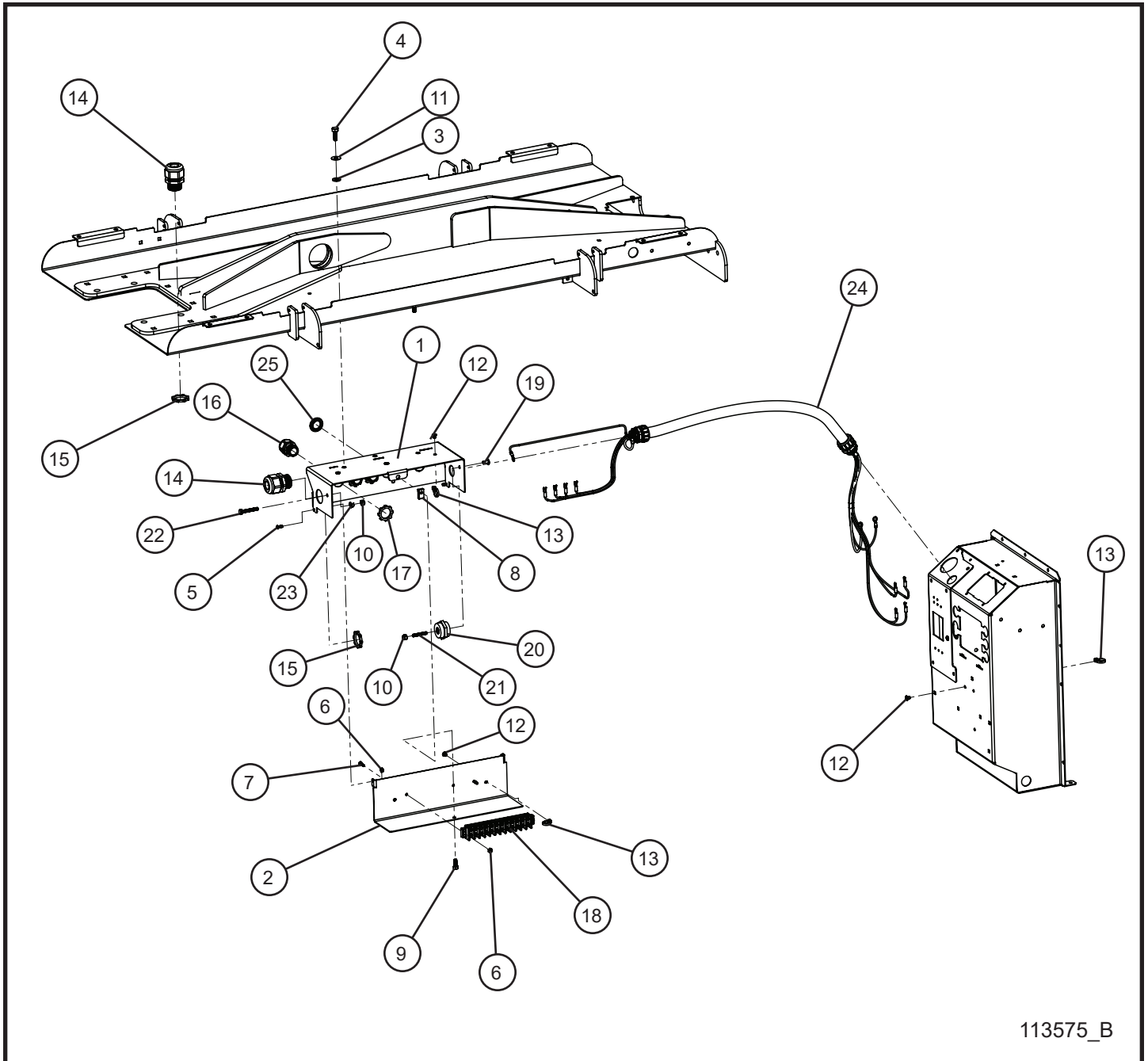

113575_B

3.13 - 4-Light COB LED Lamp Junction Box

Item	Part No.	Part Description	Qty.
1	113560P	MAXI-LITE TOP JUNCTION BOX	1
2	112559P	MAXI-LITE BOTTOM JUNCTION BOX	1
3	100644	RUBBER WASHER	3
4	046050	5/16-18 x 1 HEX HEAD BOLT	3
5	041024	#10-24 x 1/2 PH-ROUND HEAD MACHINE SCREW	2
6	044018	#10-24 NYLOCK HEX NUT	4
7	041027	#10-24 x 3/4 PH-ROUND HEAD MACHINE SCREW	2
8	044106	1/4-20 TINNEMAN NUT	3
9	046010	1/4-20 x 3/4 HEX HEAD BOLT	1
10	044023	1/4-20 NYLOCK HEX NUT	2
11	047010	5/16 FLAT WASHER	3
12	022137	PUSH BUTTON	7
13	068090	8" CABLE TIE	8
14	105627	1" CORD GRIP	2
15	022038	1" CORD GRIP NUT	2
16	105916	3/4" CORD GRIP	3
17	022036	3/4" CORD GRIP NUT	3
18	106734	12 GANG SCREW TERMINAL BLOCK	1
19	041078	1/4-20 x 1/2 PH-TRUSS HEAD MACHINE SCREW	1
20	106318	1-1/4", 1/4-20 LOW VOLTAGE INSULATOR	1
21	045003	1/4-20 x 1-1/2 STUD	1
22	046029	1/4-20 x 1 3/4 HEX HEAD BOLT	1
23	044021	1/4-20 KEPS HEX NUT	1
24	113577	MAXI-LITE 4-LIGHT HARNESS CONDUIT	1
25	103948	1" PLUG	1
NS	113624	MAXI-LITE 4-LIGHT JUNCTION BOX LED SCHEMATIC	1

3.14 - Vertical Tower 4-Light SMD LED Nycoil Tower Cord

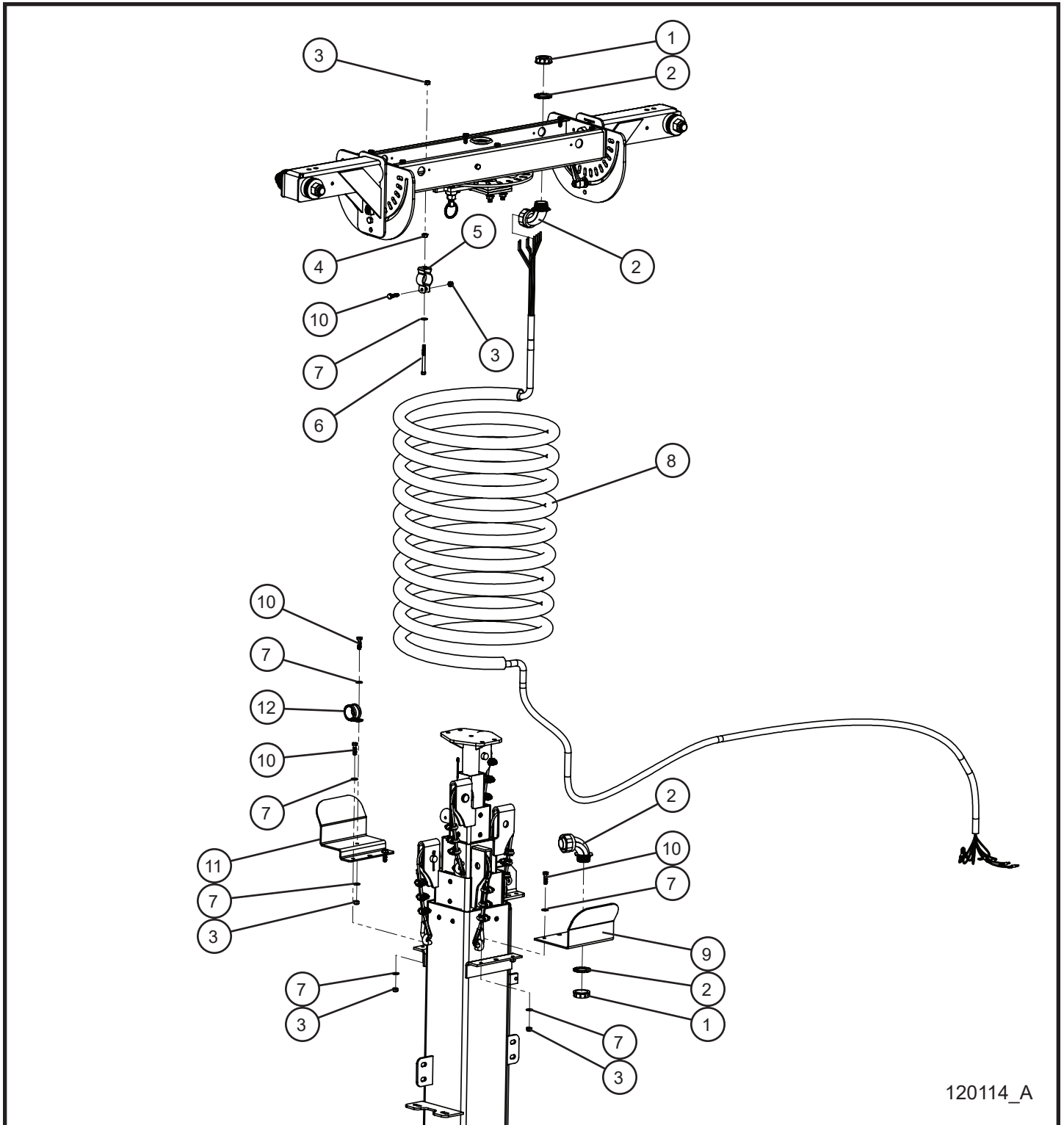

120114_A

3.14 - Vertical Tower 4-Light SMD LED Nycoil Tower Cord

Item	Part No.	Part Description	Qty.
1	101672	1" INSULATING BUSHING	2
2	102979	CORD GRIP 90° ELBOW LIQUID TIGHT	2
3	044023	1/4-20 NYLOCK HEX NUT PL	7
4	044021	1/4-20 KEPS HEX NUT PL	1
5	100474	1" CONDUIT CLAMP	1
6	046037	1/4-20 x 2 3/4 HEX HEAD CS GR5 PL	1
7	047009	1/4 FLAT WASHER SAE SS	11
8	120589	MAXI-LITE 16/8 SMB LED CORD NYCOIL ASSEMBLY (INCL. 2-102979)	1
9	102977P	CORD GRIP BRACKET	1
10	046015	1/4-20 x 1 HEX HEAD CS GR5 PL	6
11	102978P	NYCOIL CLAMP PLATE	1
12	920366	#16 CUSH CLAMP W/ 3/8 HOLE	1
NS	105292	SCHEMATIC 4 LIGHT 16/8 CORD 1P OR 208V 3P	1

*NS - NOT SHOWN

3.15 - 4-Light SMD LED Lamp Tower Cord Stringer Group

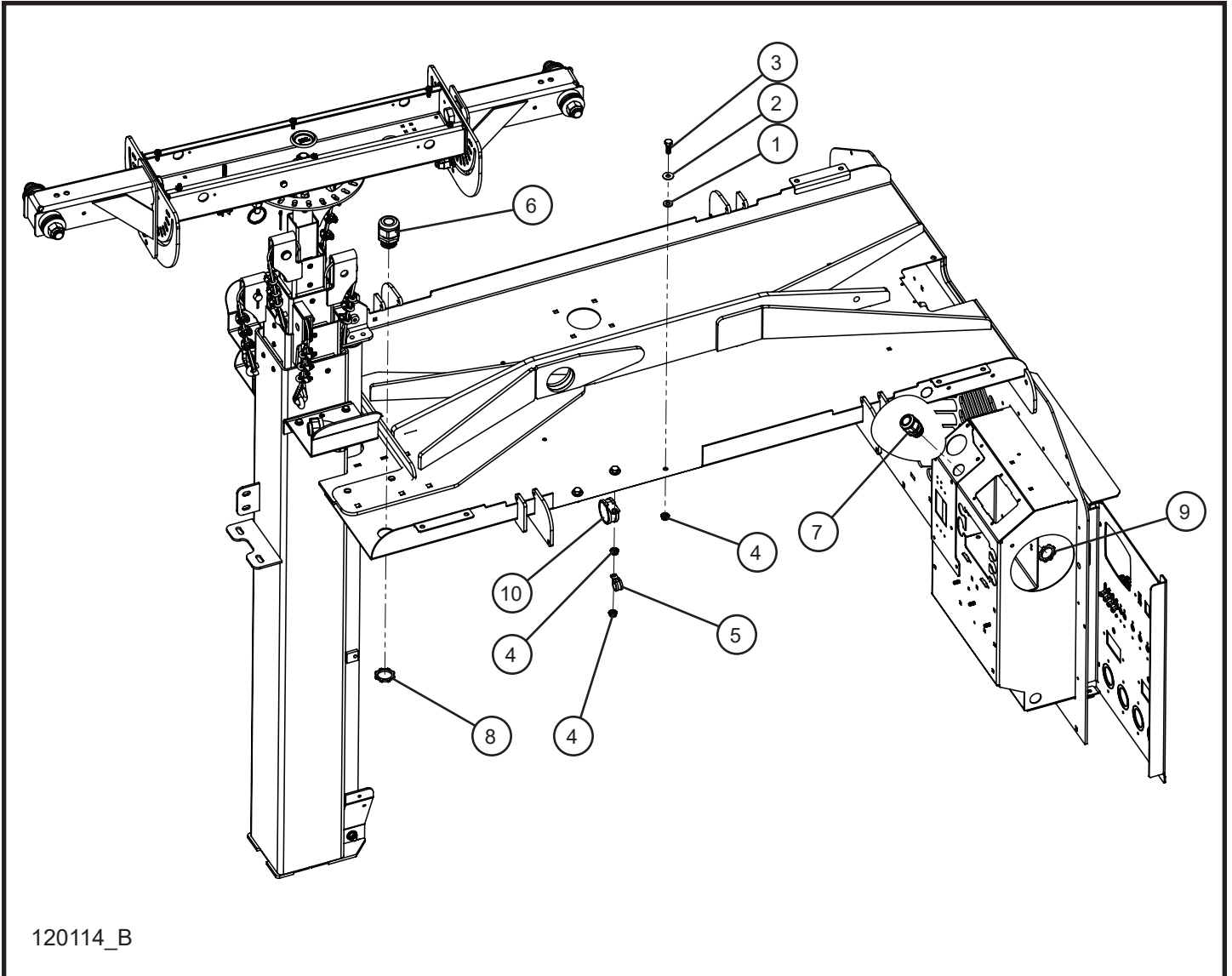

3.15 - 4-Light SMD LED Lamp Tower Cord Stringer Group

Item	Part No.	Part Description	Qty.
1	100644	RUBBER WASHER	3
2	047010	5/16 FLAT WASHER	3
3	046050	5/16-18 X 1 HEX HEAD BOLT	3
4	057006	5/16-18 SERRATED FLANGE NUT	4
5	022021	#10 CLAMP CUSH	1
6	105627	1" CORD GRIP	1
7	105916	3/4" CORD GRIP	1
8	022038	1" CORD GRIP NUT	1
9	022036	3/4" CORD GRIP NUT	1
10	106144	1 1/2 CUSH CLAMP W/ 3/8 HOLE	1
NS	120589	MAXI-LITE 16/8 SMB LED CORD NYCOIL ASSEMBLY (INCL. 2-102979)	1
NS	105292	SCHEMATIC 4 LIGHT 16/8 CORD 1P OR 208V 3P	1

*NS - NOT SHOWN

3.16 - Vertical Tower 6-Light Nycoil Tower Cord

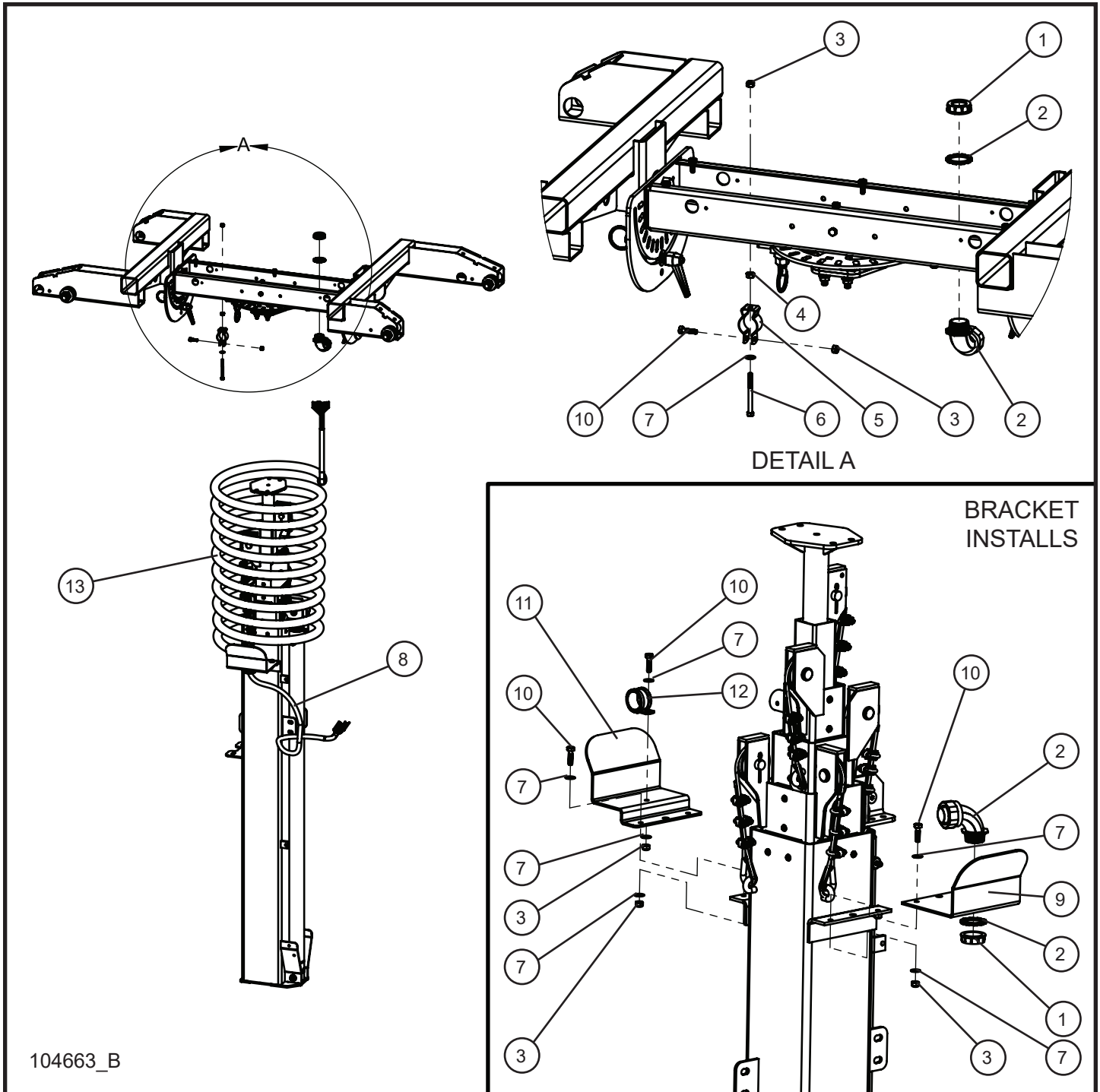

3.16 - Vertical Tower 6-Light Nycoil Tower Cord

Item	Part No.	Part Description	Qty.
1	101672	1" INSULATING BUSHING	2
2	102979	CORD GRIP 90° ELBOW LIQUID TIGHT	2
3	044023	1/4-20 NYLOCK HEX NUT PL	7
4	044021	1/4-20 KEPS HEX NUT PL	1
5	100474	1" CONDUIT CLAMP	1
6	046037	1/4-20 x 2 3/4 HEX HEAD CS GR5 PL	1
7	047009	1/4 FLAT WASHER SAE SS	11
8	120073	MAXI-LITE 16/10 CORD NYCOIL ASSEMBLY (INCL. 2-102979)	1
	120072	MAXI-LITE 16/14 LED CORD NYCOIL ASSEMBLY (INCL. 2-102979)	1
9	102977P	CORD GRIP BRACKET	1
10	046015	1/4-20 x 1 HEX HEAD CS GR5 PL	6
11	102978P	NYCOIL CLAMP PLATE	1
12	920366	#16 CUSH CLAMP W/ 3/8 HOLE	1
13	103390	HOSE SELF STORING	1
NS	105293	SCHEMATIC LIGHT BAR 4 LIGHT 16/10 CORD	1

*NS - NOT SHOWN

3.17 - 6-Light SHO Lamp Junction Box

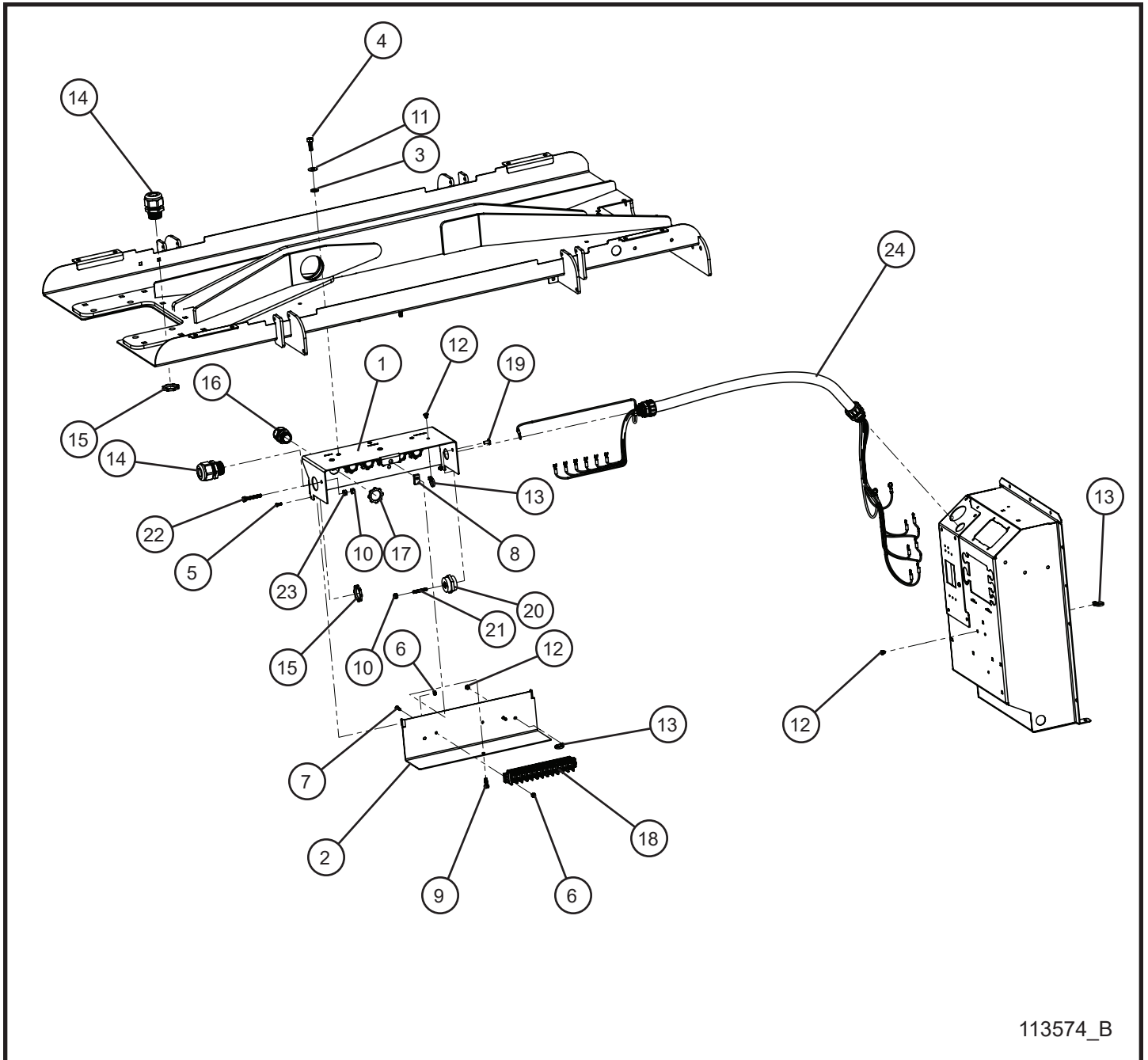

113574_B

3.17 - 6-Light SHO Lamp Junction Box

Item	Part No.	Part Description	Qty.
1	113560P	MAXI-LITE TOP JUNCTION BOX	1
2	112559P	MAXI-LITE BOTTOM JUNCTION BOX	1
3	100644	RUBBER WASHER	3
4	046050	5/16-18 x 1 HEX HEAD BOLT	3
5	041024	#10-24 x 1/2 PH-ROUND HEAD MACHINE SCREW	2
6	044018	#10-24 NYLOCK HEX NUT	4
7	041027	#10-24 x 3/4 PH-ROUND HEAD MACHINE SCREW	2
8	044106	1/4-20 TINNEMAN NUT	3
9	046010	1/4-20 x 3/4 HEX HEAD BOLT	1
10	044023	1/4-20 NYLOCK HEX NUT	2
11	047010	5/16 FLAT WASHER	3
12	022137	PUSH BUTTON	7
13	068090	8" CABLE TIE	8
14	105627	1" CORD GRIP	2
15	022038	1" CORD GRIP NUT	2
16	105916	3/4" CORD GRIP	6
17	022036	3/4" CORD GRIP NUT	6
18	106734	12 GANG SCREW TERMINAL BLOCK	1
19	122452	1/4-20 X 1/2 HEX SERRATED FLANGE BOLT W/ THREAD LOCK	1
20	106318	1-1/4", 1/4-20 LOW VOLTAGE INSULATOR	1
21	122454	1/4-20 X 1-1/2 STUD W/ THREAD LOCK	1
22	046029	1/4-20 x 1 3/4 HEX HEAD BOLT	1
23	044021	1/4-20 KEPS HEX NUT	1
24	112672	MAXI-LITE 6-LIGHT HARNESS CONDUIT	1
NS	113627	MAXI-LITE 6-LIGHT JUNCTION BOX 16/8 CORD SCHEMATIC	1

3.18 - 6-Light COB LED Lamp Junction Box

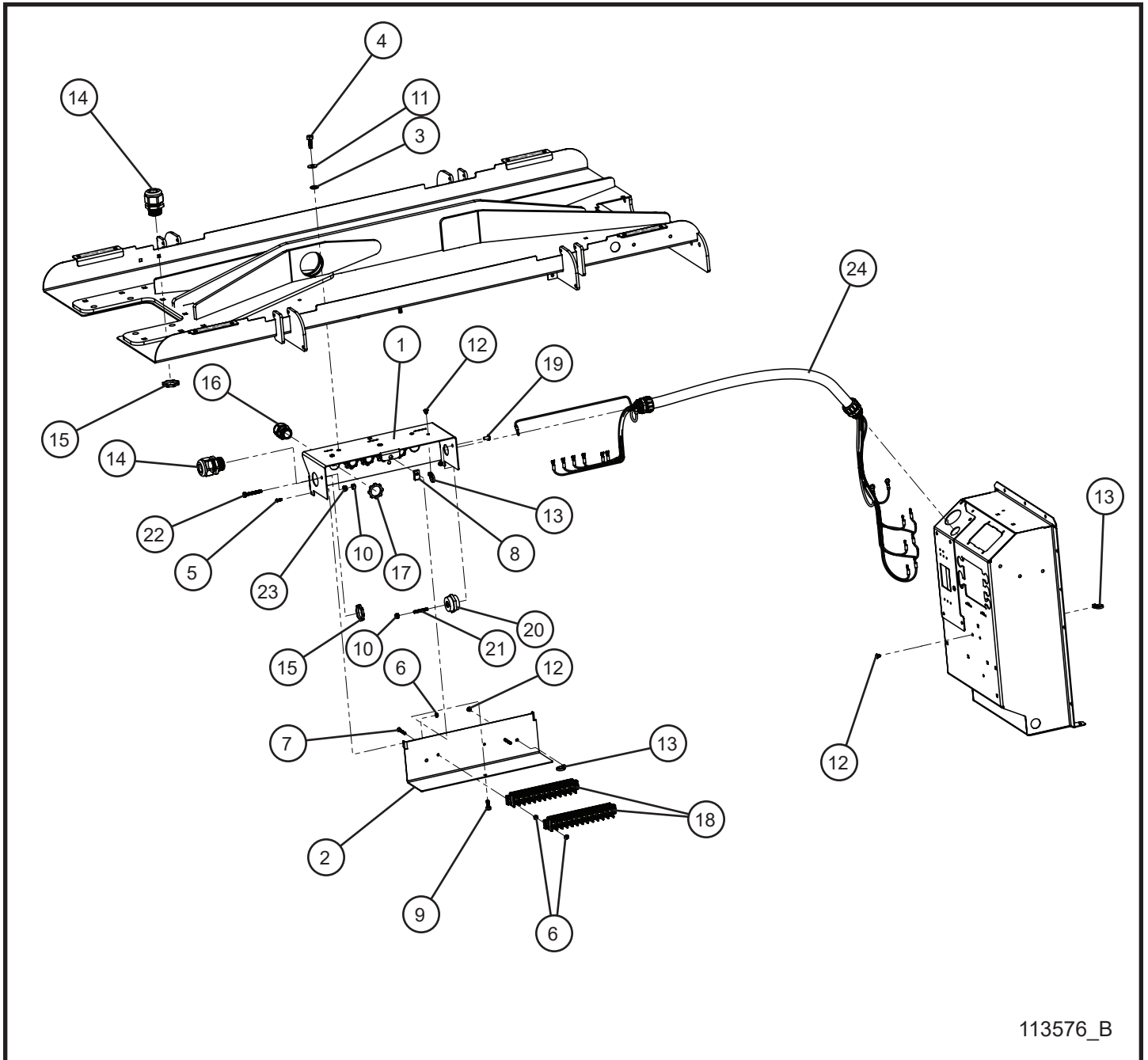

113576_B

3.18 - 6-Light LED Lamp Junction Box

Item	Part No.	Part Description	Qty.
1	113560P	MAXI-LITE TOP JUNCTION BOX	1
2	112559P	MAXI-LITE BOTTOM JUNCTION BOX	1
3	100644	RUBBER WASHER	3
4	046050	5/16-18 x 1 HEX HEAD BOLT	3
5	041024	#10-24 x 1/2 PH-ROUND HEAD MACHINE SCREW	2
6	044018	#10-24 NYLOCK HEX NUT	4
7	041040	#10-24 x 1 1/2 PH-ROUND HEAD MACHINE SCREW	2
8	044106	1/4-20 TINNEMAN NUT	3
9	046010	1/4-20 x 3/4 HEX HEAD BOLT	1
10	044023	1/4-20 NYLOCK HEX NUT	2
11	047010	5/16 FLAT WASHER	3
12	022137	PUSH BUTTON	7
13	068090	8" CABLE TIE	8
14	105627	1" CORD GRIP	2
15	022038	1" CORD GRIP NUT	2
16	105916	3/4" CORD GRIP	5
17	022036	3/4" CORD GRIP NUT	5
18	106734	12 GANG SCREW TERMINAL BLOCK	2
19	041078	1/4-20 x 1/2 PH-TRUSS HEAD MACHINE SCREW	1
20	106318	1-1/4", 1/4-20 LOW VOLTAGE INSULATOR	1
21	045003	1/4-20 x 1-1/2 STUD	1
22	046029	1/4-20 x 1 3/4 HEX HEAD BOLT	1
23	044021	1/4-20 KEPS HEX NUT	1
24	112672	MAXI-LITE 6-LIGHT HARNESS CONDUIT	1
NS	113625	MAXI-LITE 6-LIGHT JUNCTION BOX LED SCHEMATIC	1

3.19 - Vertical Tower 6-Light SMD LED Nycoil Tower Cord

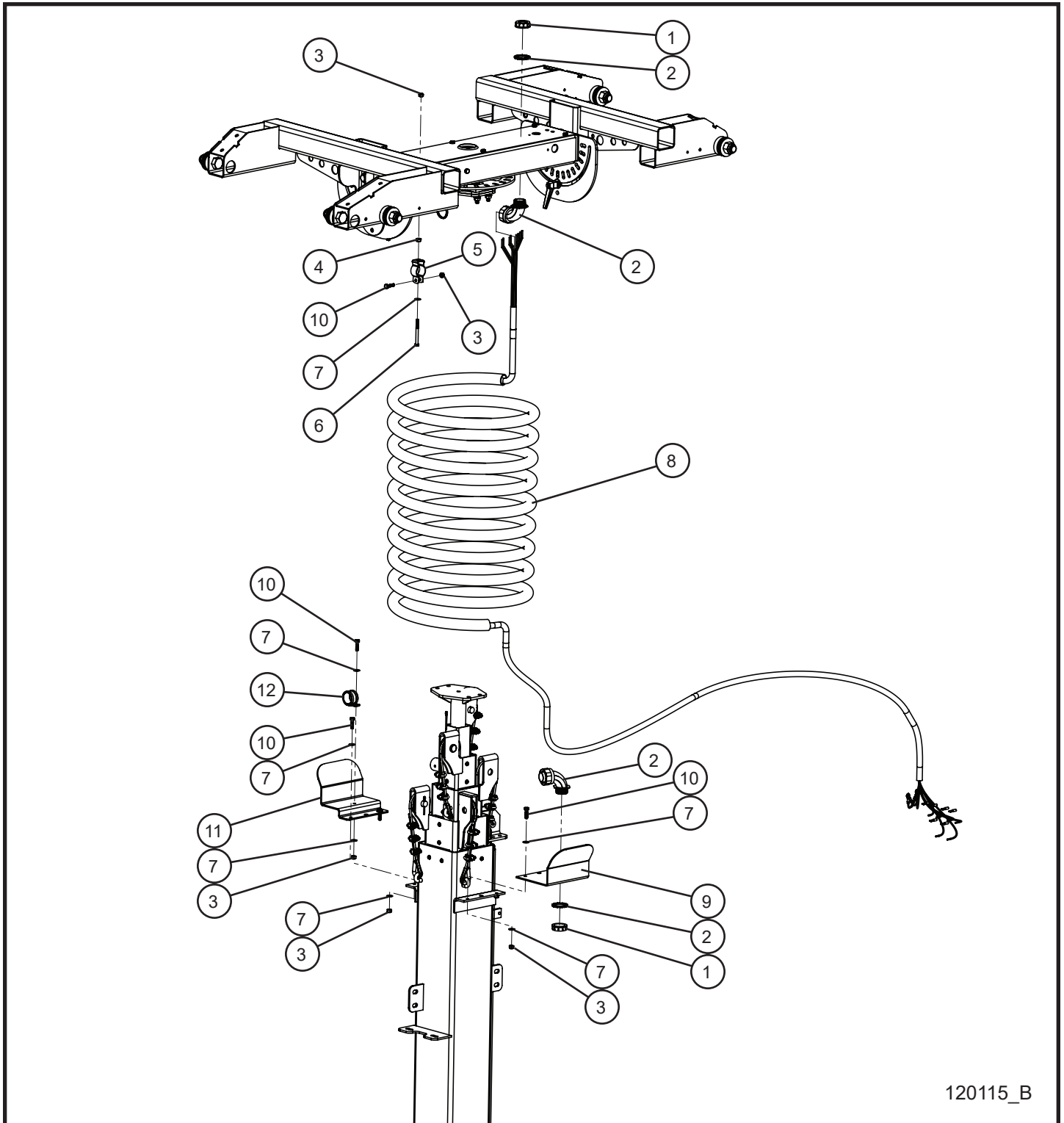

120115_B

3.19 - Vertical Tower 6-Light SMD LED Nycoil Tower Cord

Item	Part No.	Part Description	Qty.
1	101672	1" INSULATING BUSHING	2
2	102979	CORD GRIP 90° ELBOW LIQUID TIGHT	2
3	044023	1/4-20 NYLOCK HEX NUT PL	7
4	044021	1/4-20 KEPS HEX NUT PL	1
5	100474	1" CONDUIT CLAMP	1
6	046037	1/4-20 x 2 3/4 HEX HEAD CS GR5 PL	1
7	047009	1/4 FLAT WASHER SAE SS	11
8	120591	MAXI-LITE 16/10 SMD LED CORD NYCOIL ASSEMBLY (INCL. 2-102979)	1
9	102977P	CORD GRIP BRACKET	1
10	046015	1/4-20 x 1 HEX HEAD CS GR5 PL	6
11	102978P	NYCOIL CLAMP PLATE	1
12	920366	#16 CUSH CLAMP W/ 3/8 HOLE	1
NS	105293	SCHEMATIC LIGHT BAR 6 LIGHT 16/10 CORD 1P OR 208V 3P	1

*NS - NOT SHOWN

3.20 - 6-Light SMD LED Lamp Tower Cord Stringer Group

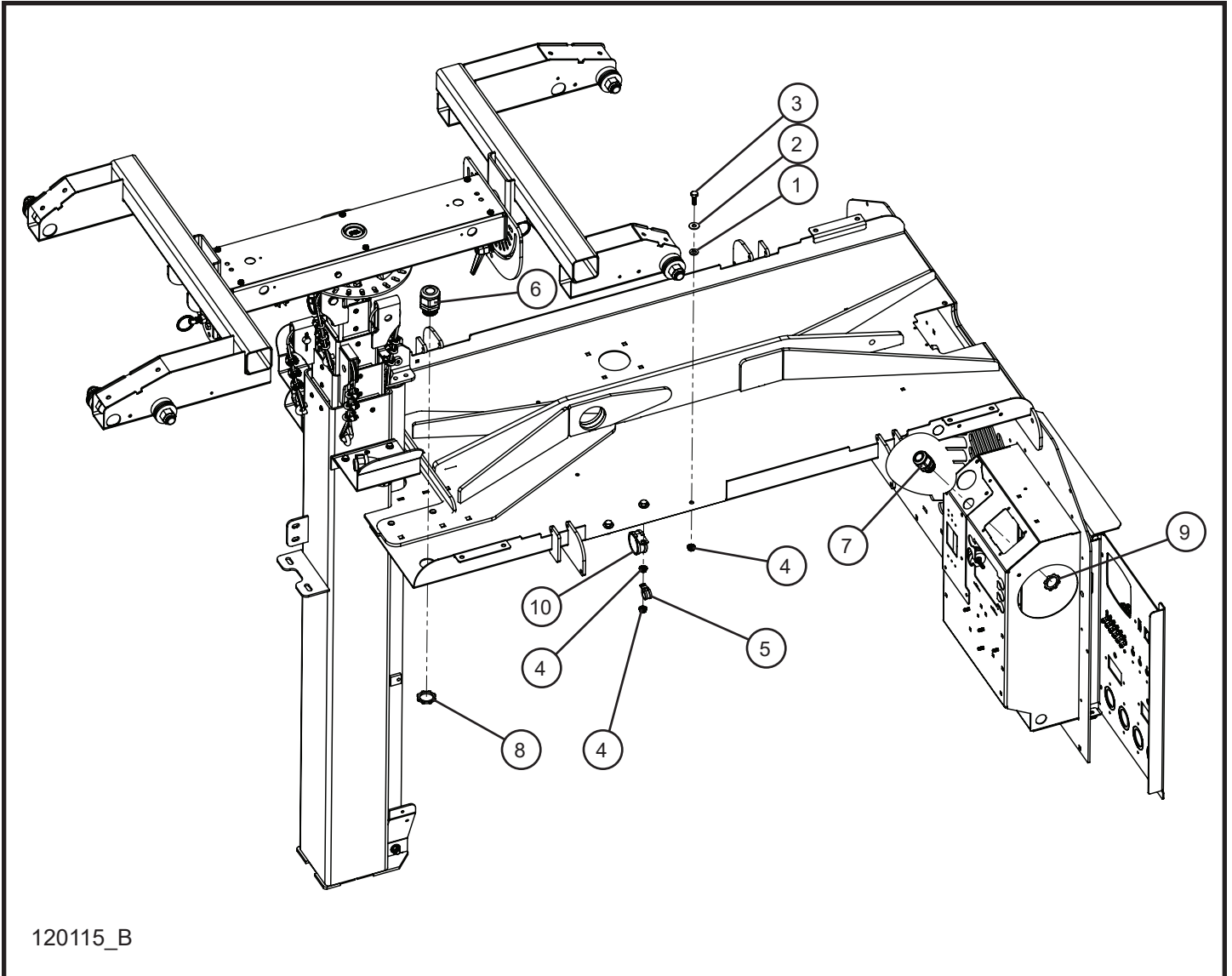

3.20 - 6-Light SMD LED Lamp Tower Cord Stringer Group

Item	Part No.	Part Description	Qty.
1	100644	RUBBER WASHER	3
2	047010	5/16 FLAT WASHER	3
3	046050	5/16-18 X 1 HEX HEAD BOLT	3
4	057006	5/16-18 SERRATED FLANGE NUT	4
5	022021	#10 CLAMP CUSH	1
6	105627	1" CORD GRIP	1
7	105916	3/4" CORD GRIP	1
8	022038	1" CORD GRIP NUT	1
9	022036	3/4" CORD GRIP NUT	1
10	106144	1 1/2 CUSH CLAMP W/ 3/8 HOLE	1
8	120591	MAXI-LITE 16/10 SMD LED CORD NYCOIL ASSEMBLY (INCL. 2-102979)	1
NS	105293	SCHEMATIC LIGHT BAR 6 LIGHT 16/10 CORD 1P OR 208V 3P	1

*NS - NOT SHOWN

4.1 - 4-Light Ballast Box Install Group

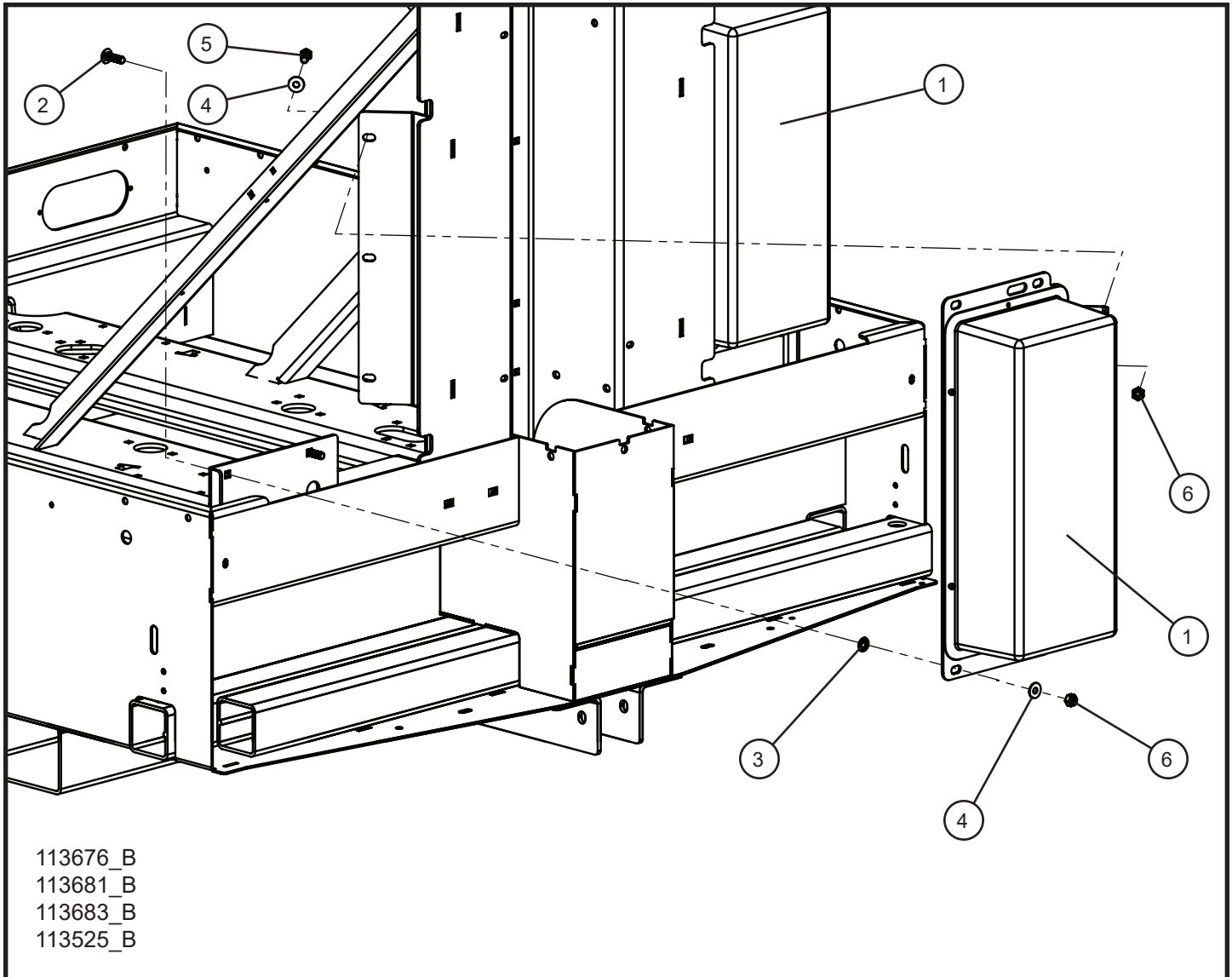

4.1 - 4-Light Ballast Box Install Group

Item	Part No.	Part Description	Qty.
1	102400	1000W 60Hz 120V BALLAST BOX ASSEMBLY	2
	102402	1000W 50Hz 120V BALLAST BOX ASSEMBLY	2
	105956	1000W 50Hz 220V BALLAST BOX ASSEMBLY	2
	104481	1250W 60Hz 120V BALLAST BOX ASSEMBLY	2
2	100670	3/8-16 x 1 1/4 CARRIAGE BOLT	4
3	045218	3/8 PUSH NUT	4
4	047010	5/16 FLAT WASHER	6
5	046110	3/8-16 x 1 HEX HEAD BOLT	2
6	044038	3/8-16 NYLOCK HEX NUT	6
NS	105184	1000W 60Hz 120V BALLAST SCHEMATIC	1
NS	105288	1000W 50Hz 120V BALLAST SCHEMATIC	1
NS	105289	1000W 50Hz 220V BALLAST SCHEMATIC	1
NS	105286	1250W 60Hz 120V BALLAST SCHEMATIC	1

*NS - NOT SHOWN

4.2 - 4-Light Ballast Box Wiring Group

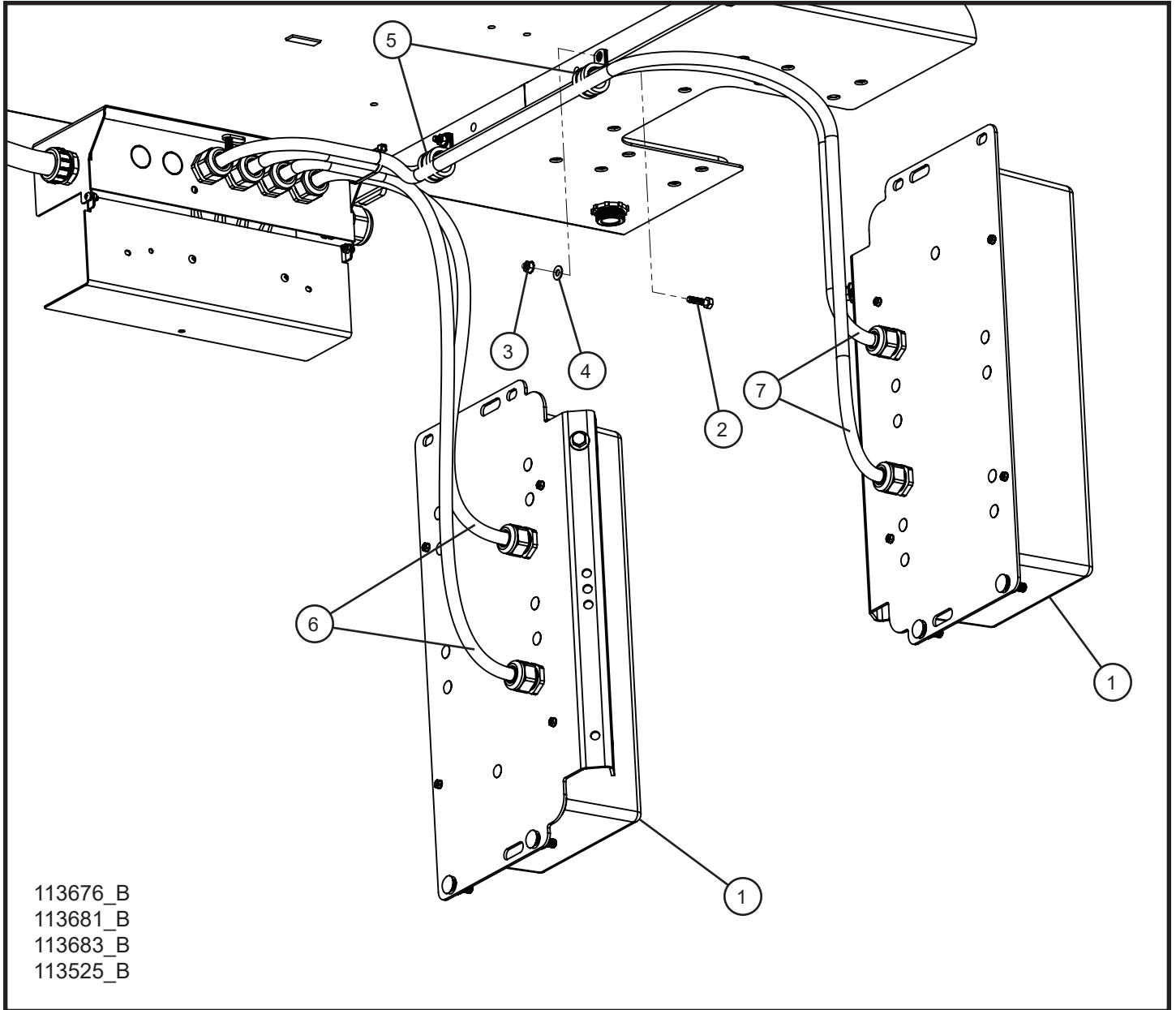

4.2 - 4-Light Ballast Box Wiring Group

Item	Part No.	Part Description	Qty.
1	102400	1000W 60Hz 120V BALLAST BOX ASSEMBLY	2
	102402	1000W 50Hz 120V BALLAST BOX ASSEMBLY	2
	105956	1000W 50Hz 220V BALLAST BOX ASSEMBLY	2
	104481	1250W 60Hz 120V BALLAST BOX ASSEMBLY	2
2	046015	1/4-20 x 1 HEX HEAD BOLT	2
3	044021	1/4-20 KEPS HEX NUT	2
4	047009	1/4 FLAT WASHER	2
5	022083	#16 CUSHION CLAMP	2
6	113527	1 & 2 BALLAST CORD MAXI-LITE	2
7	113622	3 & 4 BALLAST CORD MAXI-LITE	2
NS	105184	1000W 60Hz 120V BALLAST SCHEMATIC	1
NS	105288	1000W 50Hz 120V BALLAST SCHEMATIC	1
NS	105289	1000W 50Hz 220V BALLAST SCHEMATIC	1
NS	105286	1250W 60Hz 120V BALLAST SCHEMATIC	1

*NS - NOT SHOWN

4.3 - 6-Light Ballast Box Install Group

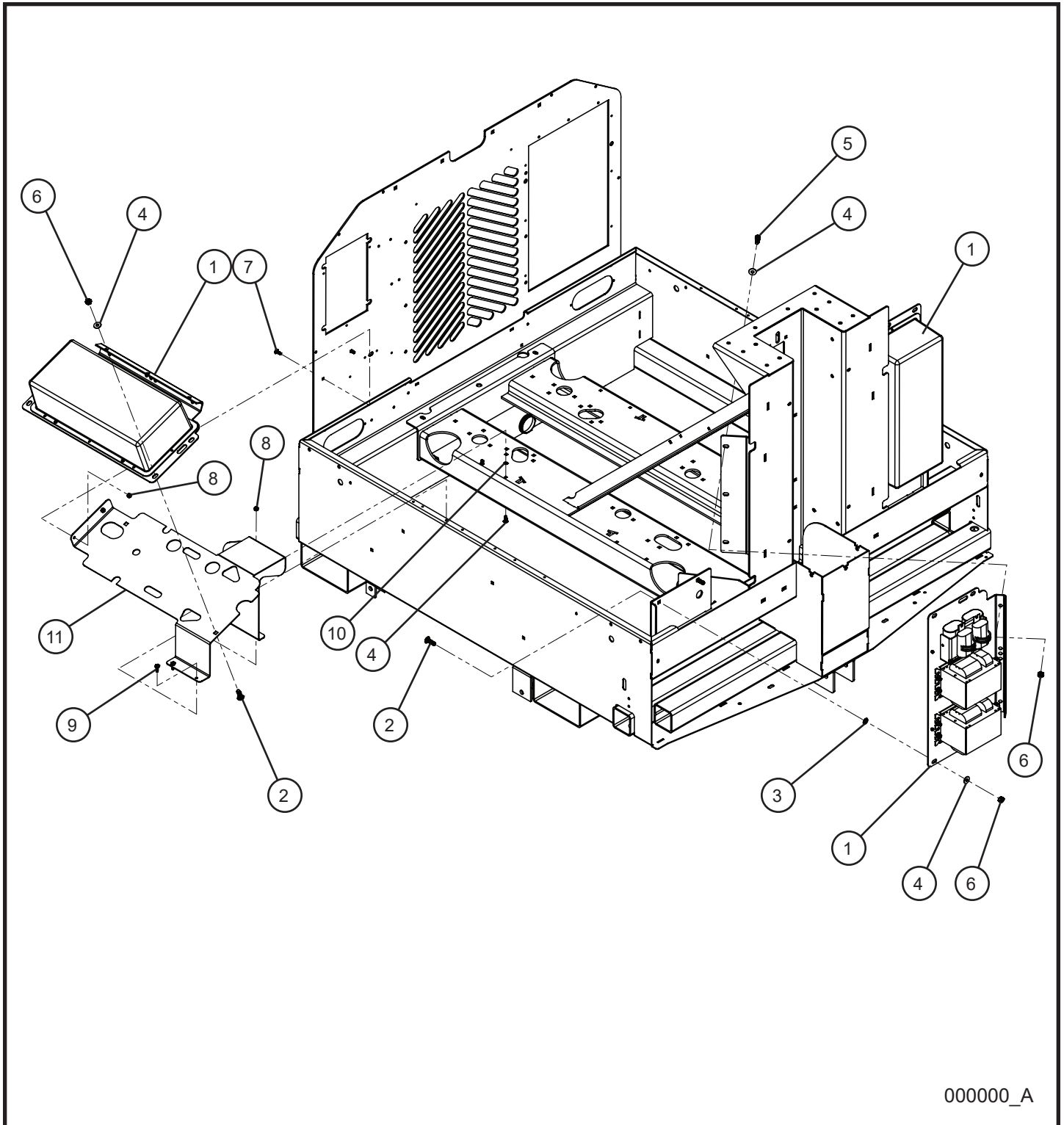

4.3 - 6-Light Ballast Box Install Group

Item	Part No.	Part Description	Qty.
1	102400	1000W 60Hz 120V BALLAST BOX ASSEMBLY	3
	102938	1000W 60Hz 120V HPS BALLAST BOX ASSEMBLY	3
	102402	1000W 50Hz 120V BALLAST BOX ASSEMBLY	3
	105956	1000W 50Hz 220V BALLAST BOX ASSEMBLY	3
	104481	1250W 60Hz 120V BALLAST BOX ASSEMBLY	3
2	100670	3/8-16 x 1 1/4 CARRIAGE BOLT	6
3	045218	3/8 PUSH NUT	4
4	047010	5/16 FLAT WASHER	8
5	046110	3/8-16 x 1 HEX HEAD BOLT	2
6	044038	3/8-16 NYLOCK HEX NUT	8
7	053006	1/4-20 x 3/4 CARRIAGE BOLT	4
8	044023	1/4-20 NYLOCK HEX NUT	4
9	041070	1/4-20 x 3/4 SL-HEX WASHER HEAD MACHINE SCREW	2
10	101701	1/4 PUSH NUT	2
11	104699P	MAXI LITE 6 LIGHT BALLAST BOX MOUNT BRACKET	1
NS	105184	1000W 60Hz 120V BALLAST SCHEMATIC	1
NS	105288	1000W 50Hz 120V BALLAST SCHEMATIC	1
NS	105289	1000W 50Hz 220V BALLAST SCHEMATIC	1
NS	105286	1250W 60Hz 120V BALLAST SCHEMATIC	1

*NS - NOT SHOWN

4.4 - 6-Light Ballast Box Wiring Group

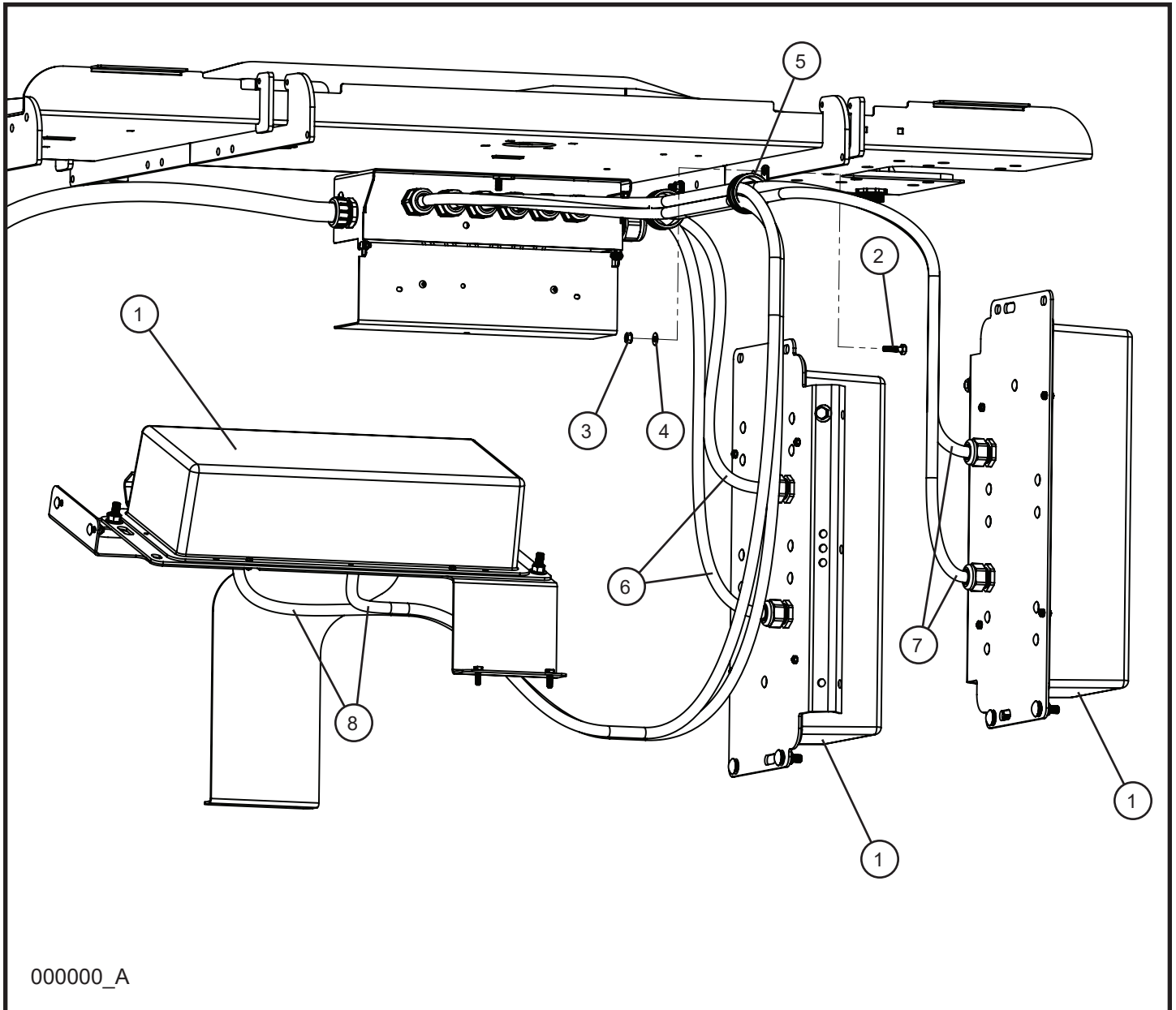

000000_A

4.4 - 6-Light Ballast Box Wiring Group

Item	Part No.	Part Description	Qty.
1	102400	1000W 60Hz 120V BALLAST BOX ASSEMBLY	3
	102938	1000W 60Hz 120V HPS BALLAST BOX ASSEMBLY	3
	102402	1000W 50Hz 120V BALLAST BOX ASSEMBLY	3
	105956	1000W 50Hz 220V BALLAST BOX ASSEMBLY	3
	104481	1250W 60Hz 120V BALLAST BOX ASSEMBLY	3
2	046015	1/4-20 x 1 HEX HEAD BOLT	2
3	044021	1/4-20 KEPS HEX NUT	2
4	047009	1/4 FLAT WASHER	2
5	106144	#2013 CUSHION CLAMP	2
6	113527	1 & 2 BALLAST CORD MAXI-LITE	2
7	113622	3 & 4 BALLAST CORD MAXI-LITE	2
8	113623	5 & 6 BALLAST CORD MAXI-LITE	2
NS	105184	1000W 60Hz 120V BALLAST SCHEMATIC	1
NS	105288	1000W 50Hz 120V BALLAST SCHEMATIC	1
NS	105289	1000W 50Hz 220V BALLAST SCHEMATIC	1
NS	105286	1250W 60Hz 120V BALLAST SCHEMATIC	1

*NS - NOT SHOWN

4.5 - 1000W 60Hz 120V Ballast Box Assembly

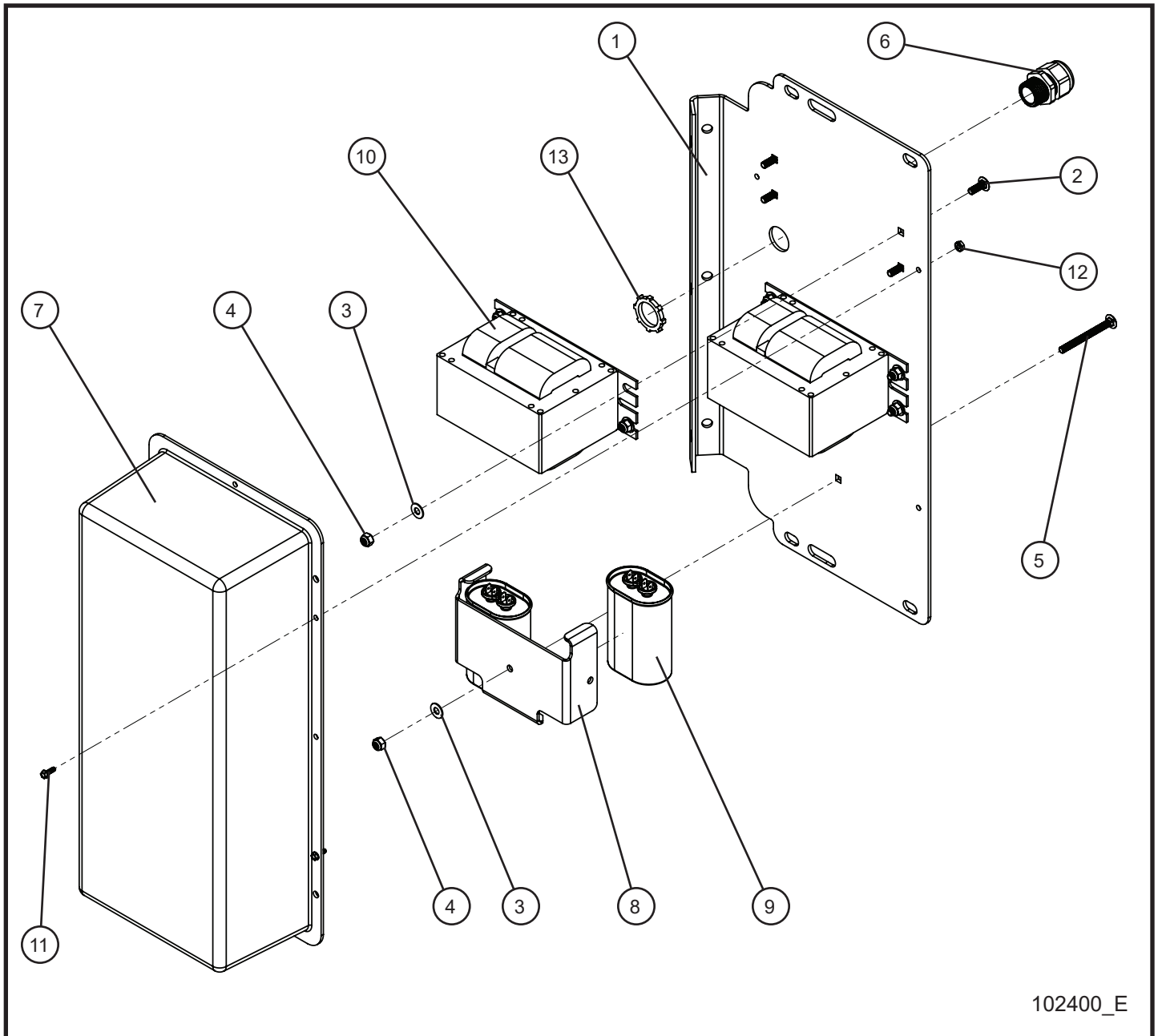

102400_E

4.5 - 1000W 60Hz 120V Ballast Box Assembly

Item	Part No.	Part Description	Qty.
1	105914P	MOUNT PLATE BALLAST BOX	1
2	053006	1/4-20 x 3/4 CARRIAGE BOLT	8
3	047009	1/4 FLAT WASHER SAE SS	9
4	044023	1/4-20 NYLOCK HEX NUT PL	9
5	100718	1/4-20 x 2 1/4 CARRIAGE BOLT	1
6	105916	GRIP CORD NYLON 3/4	2
7	102752	BALLAST TOP MODULAR BOX	1
8	680608P	TABBED CAPACITOR CLAMP	1
9	310115	CAPACITOR 24uF 1000W	2
10	310124	BALLAST 1000W 60Hz 120V	2
11	041029	#8-32 x 1/2 HEX WASHER HEAD SCREW	4
12	044003	#8-32 NC KEPS NUT	4
13	022036	3/4 CORD GRIP NUT	2
NS	105287	SCHEMATIC BALLAST 1000W 60Hz 120V	1

*NS - NOT SHOWN

4.6 - 1000W 60Hz 120V HPS Ballast Box Assembly

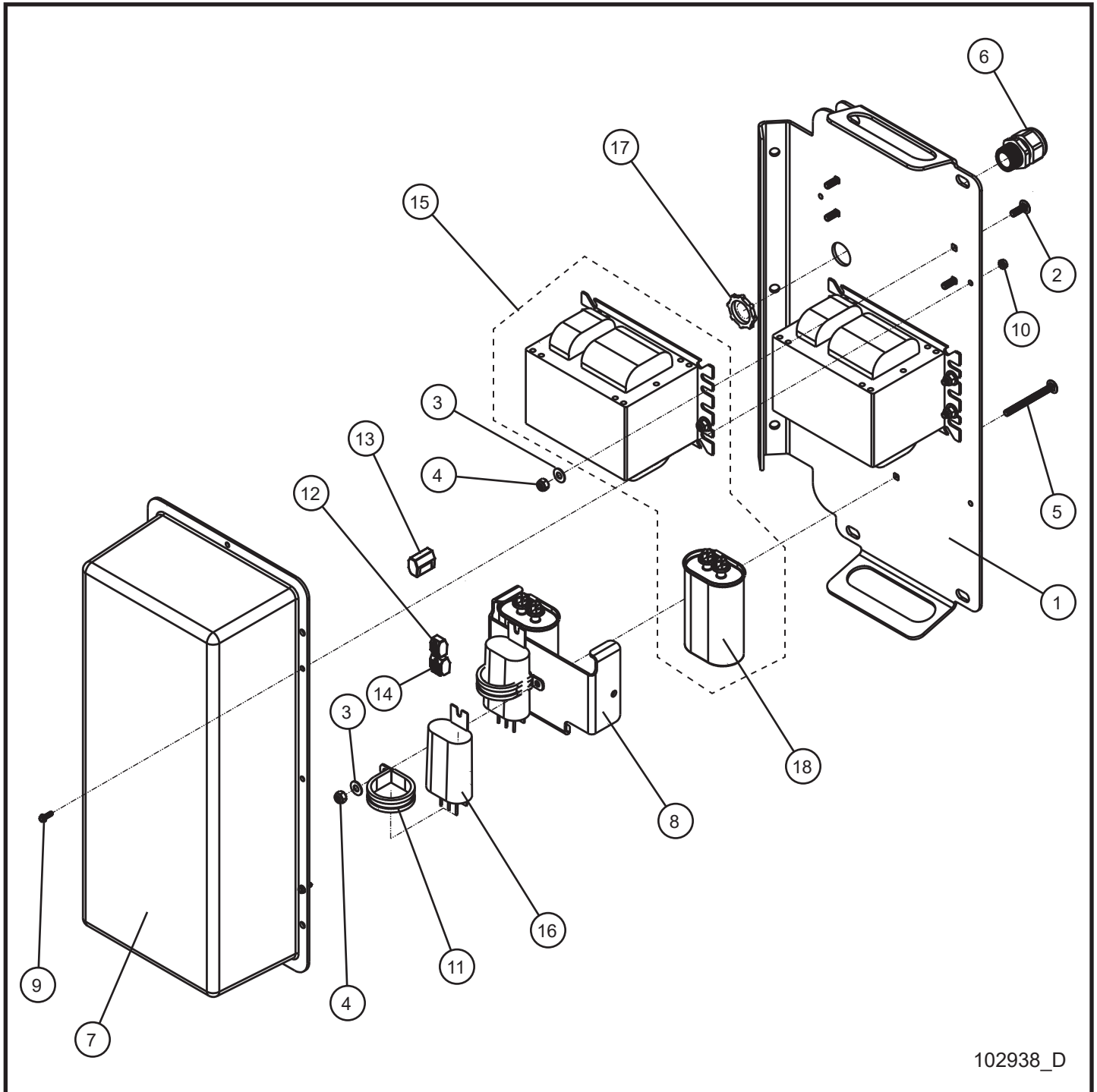

102938_D

4.6 - 1000W 60Hz 120V HPS Ballast Box Assembly

Item	Part No.	Part Description	Qty.
1	105914P	MOUNT PLATE BALLAST BOX	1
2	053006	1/4-20 x 3/4 CARRIAGE BOLT	8
3	047009	1/4 FLAT WASHER SAE SS	9
4	044023	1/4-20 NYLOCK HEX NUT PL	9
5	100718	1/4-20 x 2 1/4 CARRIAGE BOLT	1
6	105916	GRIP CORD NYLON 3/4"	2
7	102752	BALLAST TOP MODULAR BOX	1
8	680608P	TAPPED CAPACITOR CLAMP	1
9	041029	#8-32 x 1/2 HEX WASHER HEAD SCREW	4
10	044003	#8-32 NC KEPS NUT	4
11	920365	#28 CUSHION CLAMP	2
12	102624	2 WIRE LEVER LOCK	4
13	102622	CONNECTOR BLOCK 5 TERMINAL LEVERS	2
14	102623	3 PIN LEVER LOCK	2
15	310118	BALLAST KIT 1000W 60Hz 120V HPS (INCLUDES 310115A)	2
16	028015	LAMP IGNITOR 1000W	2
17	022036	3/4 CORD GRIP NUT	2
18	310115A	CAPACITOR 26UF 60/50Hz 540V	2
NS	105184	1000W 120V HPS BALLAST 60Hz SCHEMATIC	1

*NS - NOT SHOWN

4.7 - 1000W 50Hz 120V Ballast Box Assembly

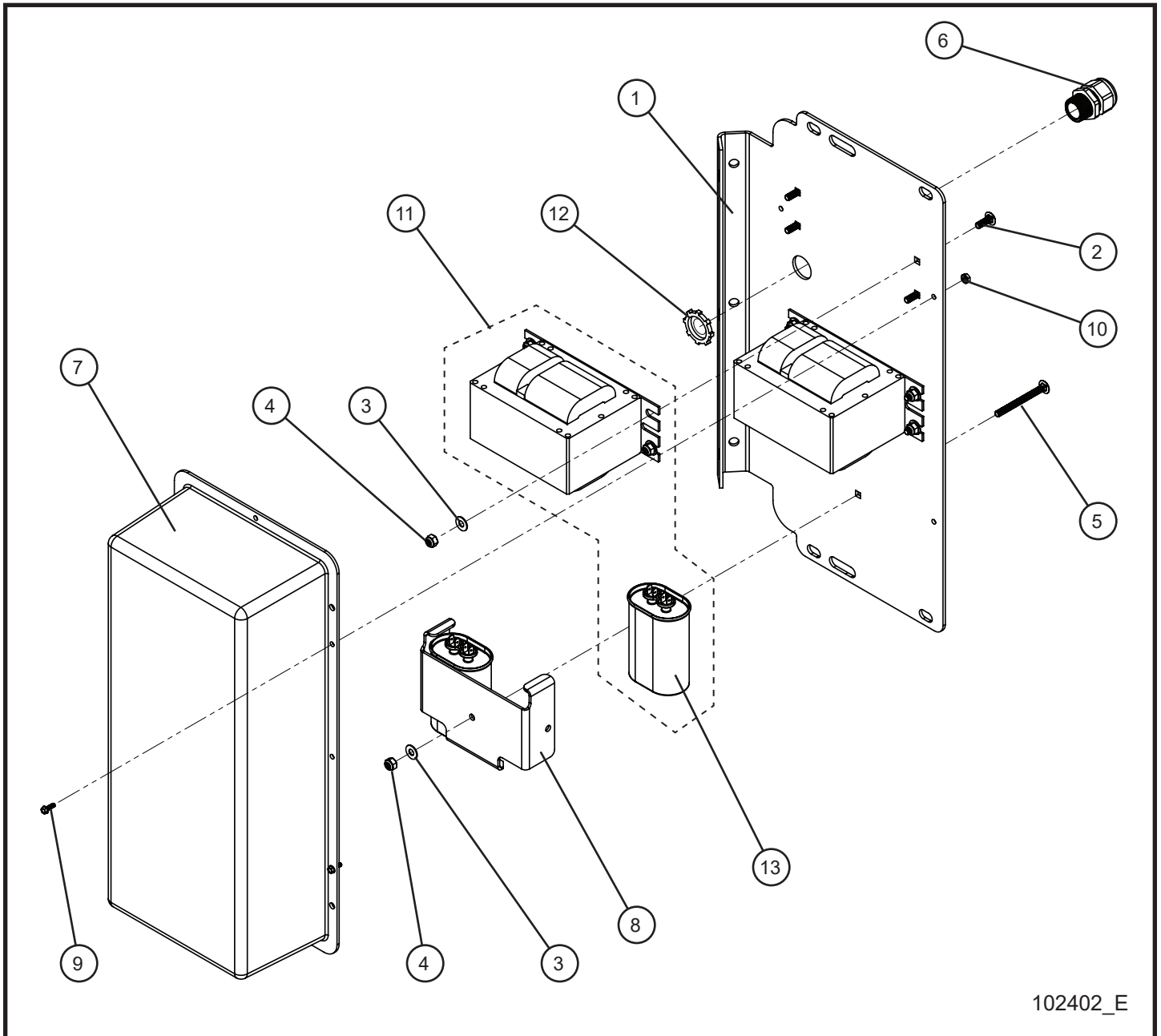

102402_E

4.7 - 1000W 50Hz 120V Ballast Box Assembly

Item	Part No.	Part Description	Qty.
1	105914P	MOUNT PLATE BALLAST BOX	1
2	053006	1/4-20 x 3/4 CARRIAGE BOLT	8
3	047009	1/4 FLAT WASHER SAE SS	9
4	044023	1/4-20 NYLOCK HEX NUT PL	9
5	100718	1/4-20 x 2 1/4 CARRIAGE BOLT	1
6	105916	GRIP CORD NYLON 3/4	2
7	102752	BALLAST TOP MODULAR BOX	1
8	680608P	TABBED CAPACITOR CLAMP	1
9	041029	#8-32 x 1/2 HEX WASHER HEAD SCREW	4
10	044003	#8-32 NC KEPS NUT	4
11	310116A	BALLAST KIT 1000W 50Hz	2
12	022036	3/4 CORD GRIP NUT	2
13	310115A	CAPACITOR 26UF 60/50Hz 540V	2
NS	105288	SCHEMATIC BALLAST 1000W 50Hz	1

*NS - NOT SHOWN

4.8 - 1000W 50Hz 220V Ballast Box Assembly

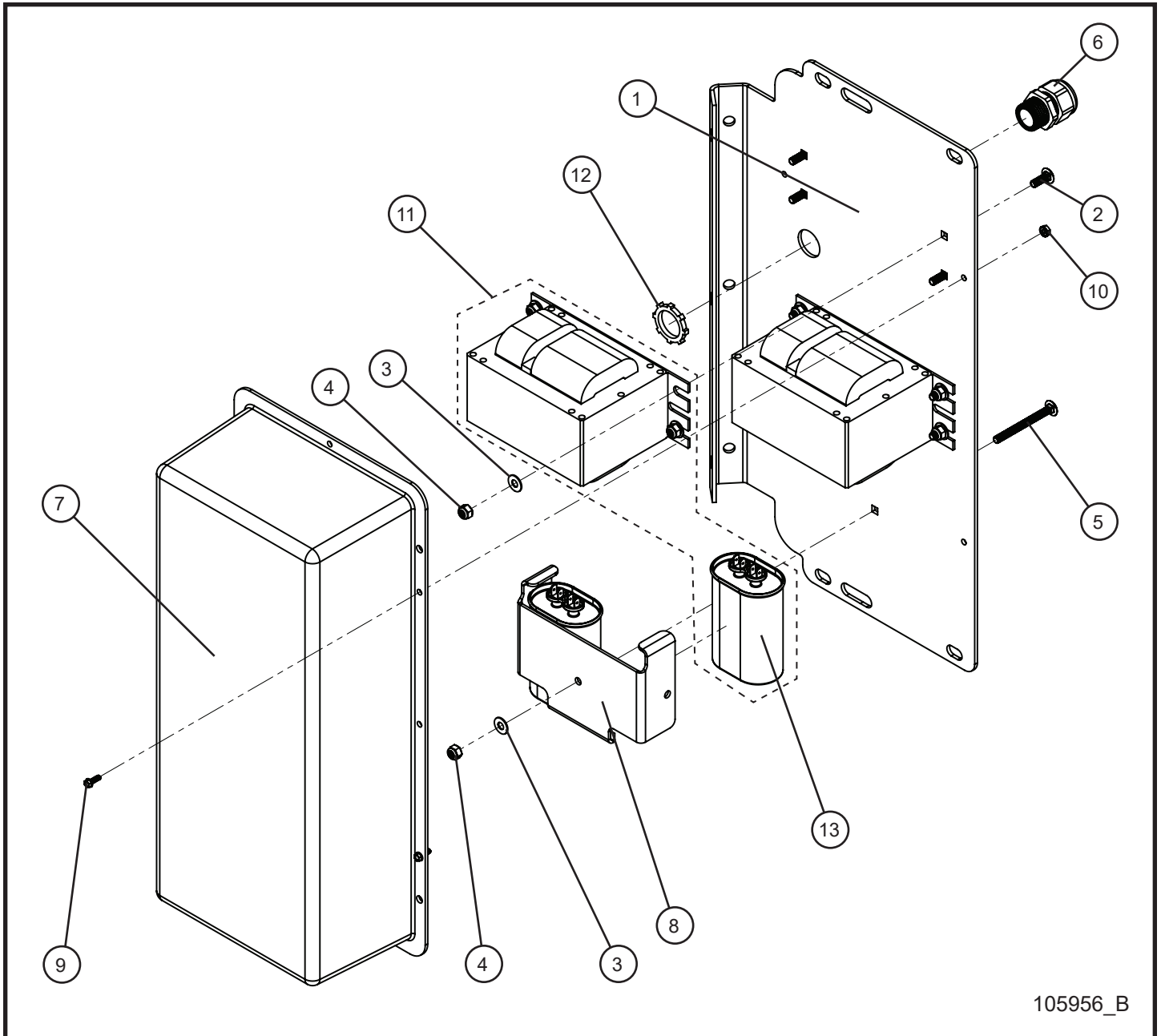

105956_B

4.8 - 1000W 50Hz 220V Ballast Box Assembly

Item	Part No.	Part Description	Qty.
1	105914P	MOUNT PLATE BALLAST BOX	1
2	053006	1/4-20 x 3/4 CARRIAGE BOLT	8
3	047009	1/4 FLAT WASHER SAE SS	9
4	044023	1/4-20 NYLOCK HEX NUT PL	9
5	100718	1/4-20 x 2 1/4 CARRIAGE BOLT	1
6	105916	GRIP CORD NYLON 3/4	2
7	102752	BALLAST TOP MODULAR BOX	1
8	680608P	TABBED CAPACITOR CLAMP	1
9	041029	#8-32 x 1/2 HEX WASHER HEAD SCREW	4
10	044003	#8-32 NC KEPS NUT	4
11	310116A	BALLAST KIT 1000W 50Hz	2
12	022036	3/4 CORD GRIP NUT	2
13	310115A	CAPACITOR 26UF 60/50Hz 540V	2
NS	105289	SCHEMATIC BALLAST 1000W 50Hz 220V	1

*NS - NOT SHOWN

4.9 - 1250W 60Hz 120V Ballast Box Assembly

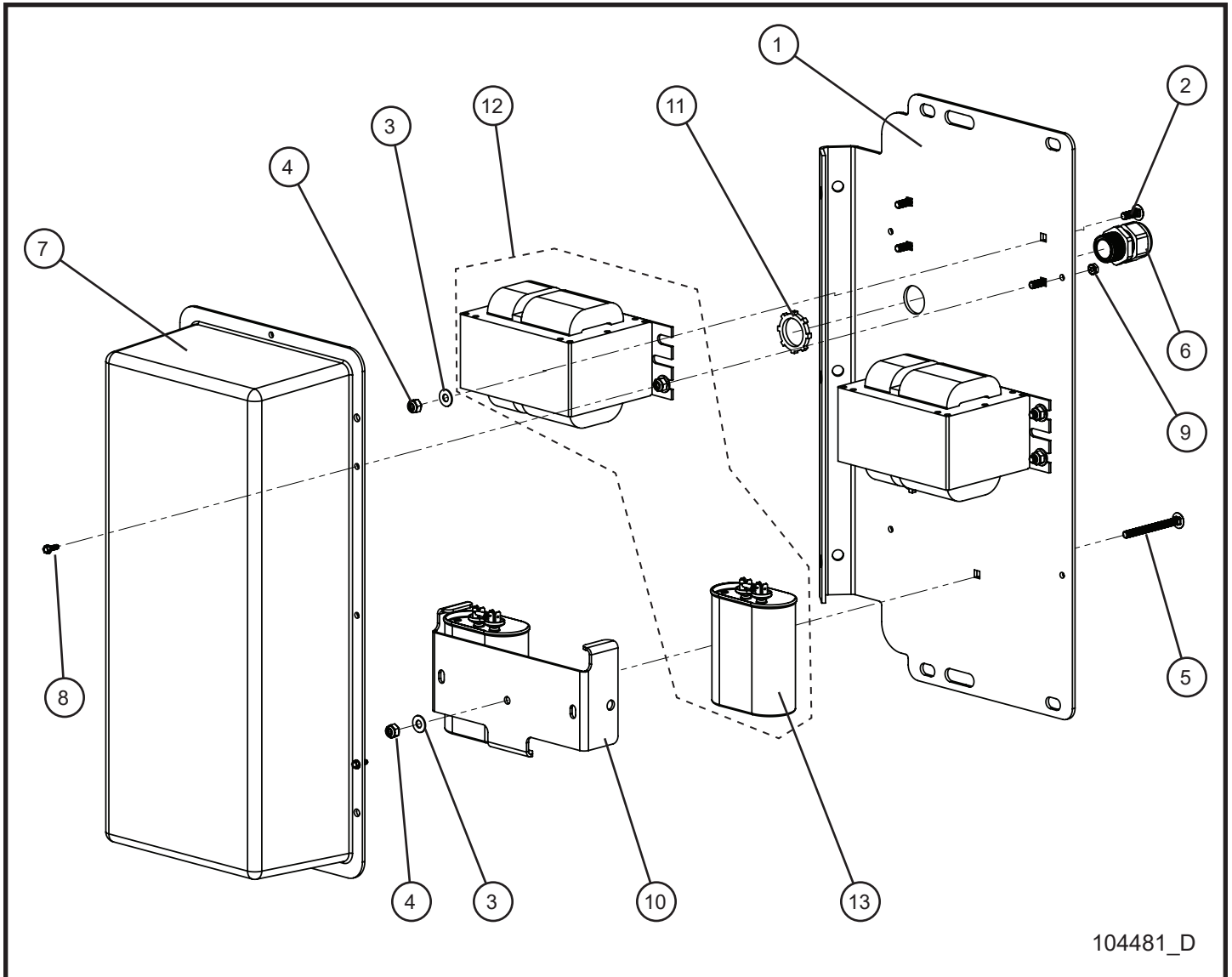

104481_D

4.9 - 1250W 60Hz 120V Ballast Box Assembly

Item	Part No.	Part Description	Qty.
1	105914P	MOUNT PLATE BALLAST BOX	1
2	053006	1/4-20 x 3/4 CARRIAGE BOLT	8
3	047009	1/4 FLAT WASHER SAE SS	9
4	044023	1/4-20 NYLOCK HEX NUT PL	9
5	100718	1/4-20 x 2 1/4 CARRIAGE BOLT	1
6	105916	GRIP CORD NYLON 3/4	2
7	102752	BALLAST TOP MODULAR BOX	1
8	041029	#8-32 x 1/2 HEX WASHER HEAD SCREW	4
9	044003	#8-32 NC KEPS NUT	4
10	100392P	TABBED CAPACITOR CLAMP	1
11	022036	3/4 CORD GRIP NUT	2
12	109606	BALLAST KIT 1250W 60Hz 120/240V 28uF (INCLUDES 100329)	2
13	100329	CAPACITOR 28uF 1250W	2
NS	105286	SCHEMATIC 60Hz 1250W	1

*NS - NOT SHOWN

4.10 - 4-Light COB LED Drivers Install Group

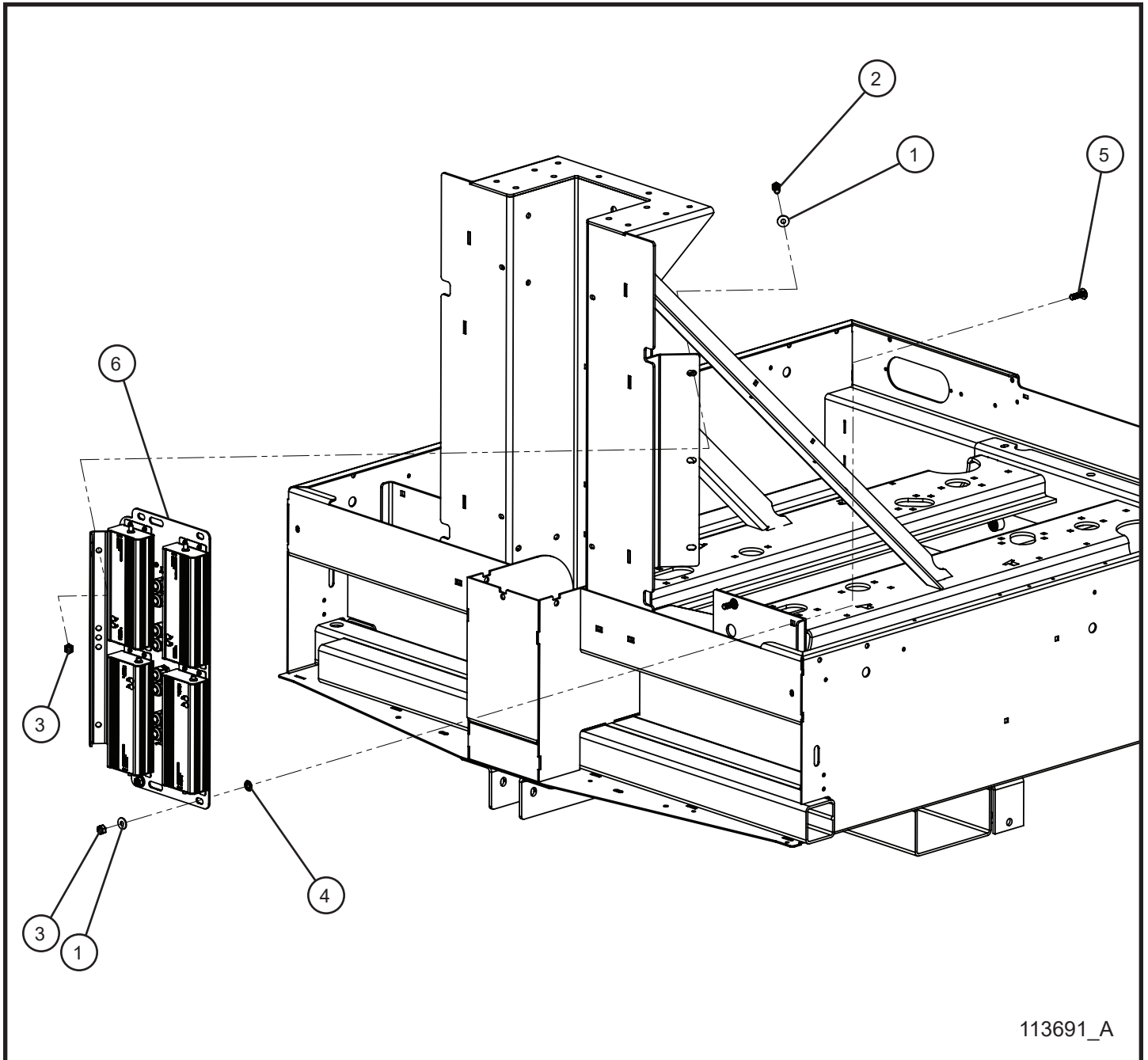

113691_A

4.10 - 4-Light COB LED Drivers Install Group

Item	Part No.	Part Description	Qty.
1	047010	5/16 FLAT WASHER	3
2	046110	3/8-16 x 1 HEX HEAD BOLT	1
3	044038	3/8-16 NYLOCK HEX NUT	3
4	045218	3/8 PUSH NUT	2
5	100670	3/8-16 x 1 1/4 CARRIAGE BOLT	2
6	117354	FOUR DRIVER LED LIGHTING ASSEMBLY	1
NS	117355	WIRE SCHEMATIC DRIVER 1 THROUGH 4 MAXI-LITE	1
NS	113624	WIRE SCHEMATIC 4 LED JUNCTION BOX MAXI-LITE	1

*NS - NOT SHOWN

4.11 - 4-Light COB LED Drivers Wiring Group

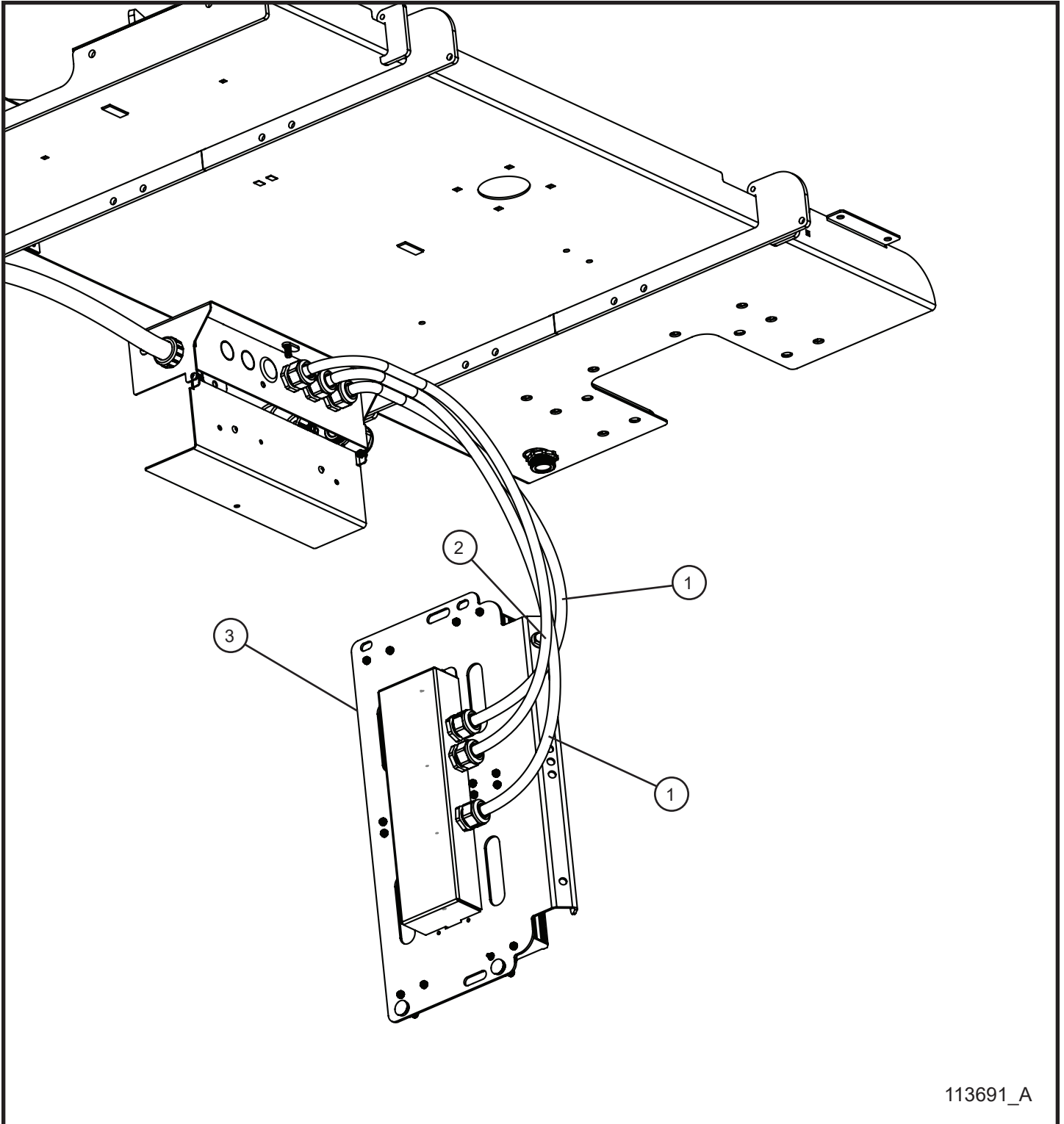

113691_A

4.11 - 4-Light COB LED Drivers Wiring Group

Item	Part No.	Part Description	Qty.
1	113708	LED 1-4 DRIVERS MAXI-LITE AC CORD	2
2	113709	LED 1-4 DRIVERS MAXI-LITE DC CORD	1
3	111959	FOUR DRIVER LED LIGHTING ASSEMBLY	1
NS	117355	WIRE SCHEMATIC DRIVER 1 THROUGH 4 MAXI-LITE	1
NS	113624	WIRE SCHEMATIC 4 LED JUNCTION BOX MAXI-LITE	1

*NS - NOT SHOWN

4.12 - 6-Light COB LED Drivers Install Group

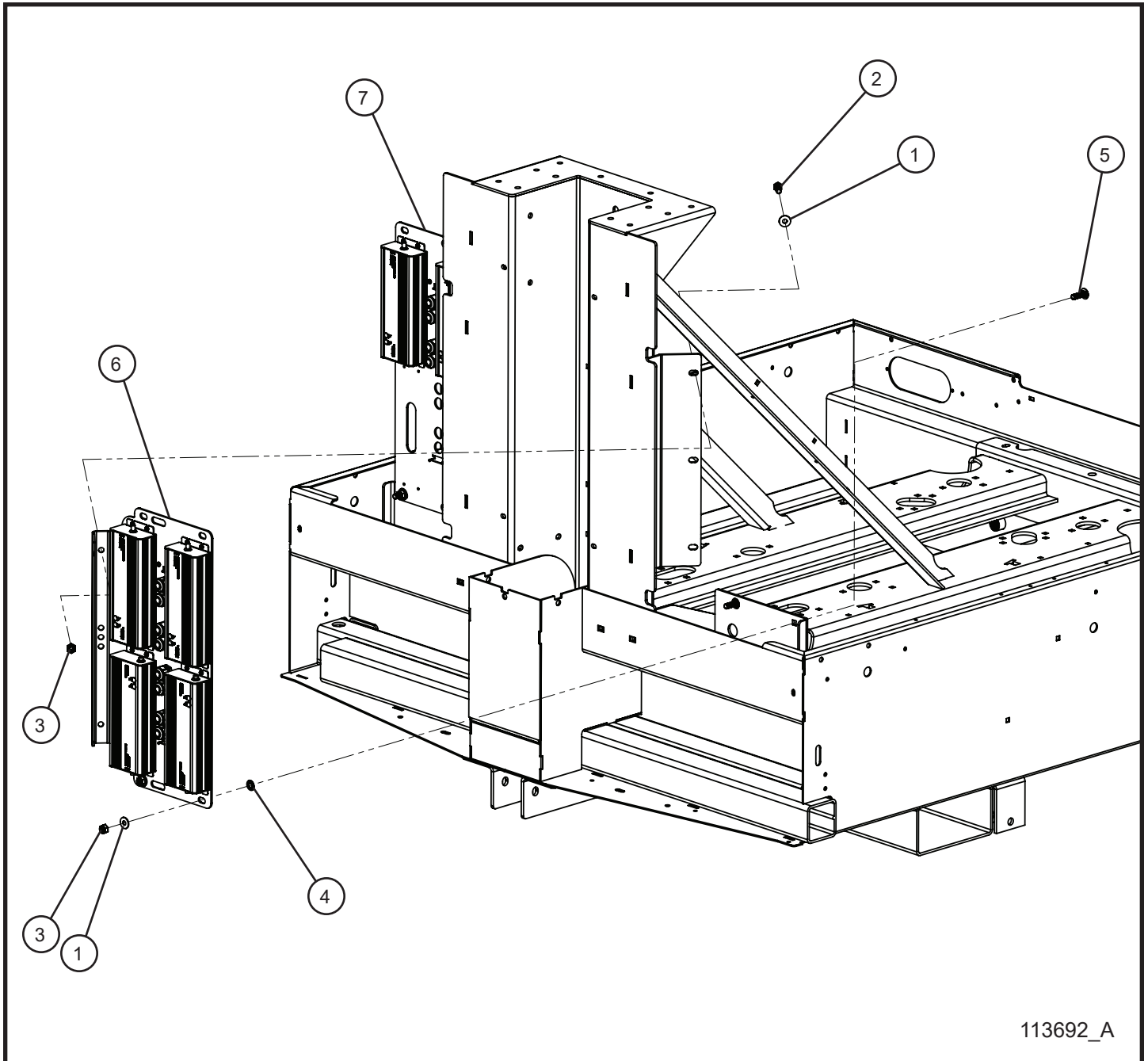

113692_A

4.12 - 6-Light COB LED Drivers Install Group

Item	Part No.	Part Description	Qty.
1	047010	5/16 FLAT WASHER	6
2	046110	3/8-16 x 1 HEX HEAD BOLT	2
3	044038	3/8-16 NYLOCK HEX NUT	6
4	045218	3/8 PUSH NUT	4
5	100670	3/8-16 x 1 1/4 CARRIAGE BOLT	4
6	117354	FOUR DRIVER LED LIGHTING ASSEMBLY	1
7	111472	TWO DRIVER LED LIGHTING ASSEMBLY	1
NS	110094	WIRE SCHEMATIC DRIVER 5 THROUGH 6 MAXI-LITE	1
NS	117355	WIRE SCHEMATIC DRIVER 1 THROUGH 4 MAXI-LITE	1
NS	113625	WIRE SCHEMATIC 6 LED JUNCTION BOX MAXI-LITE	1

*NS - NOT SHOWN

4.13 - 6-Light COB LED Drivers Wiring Group

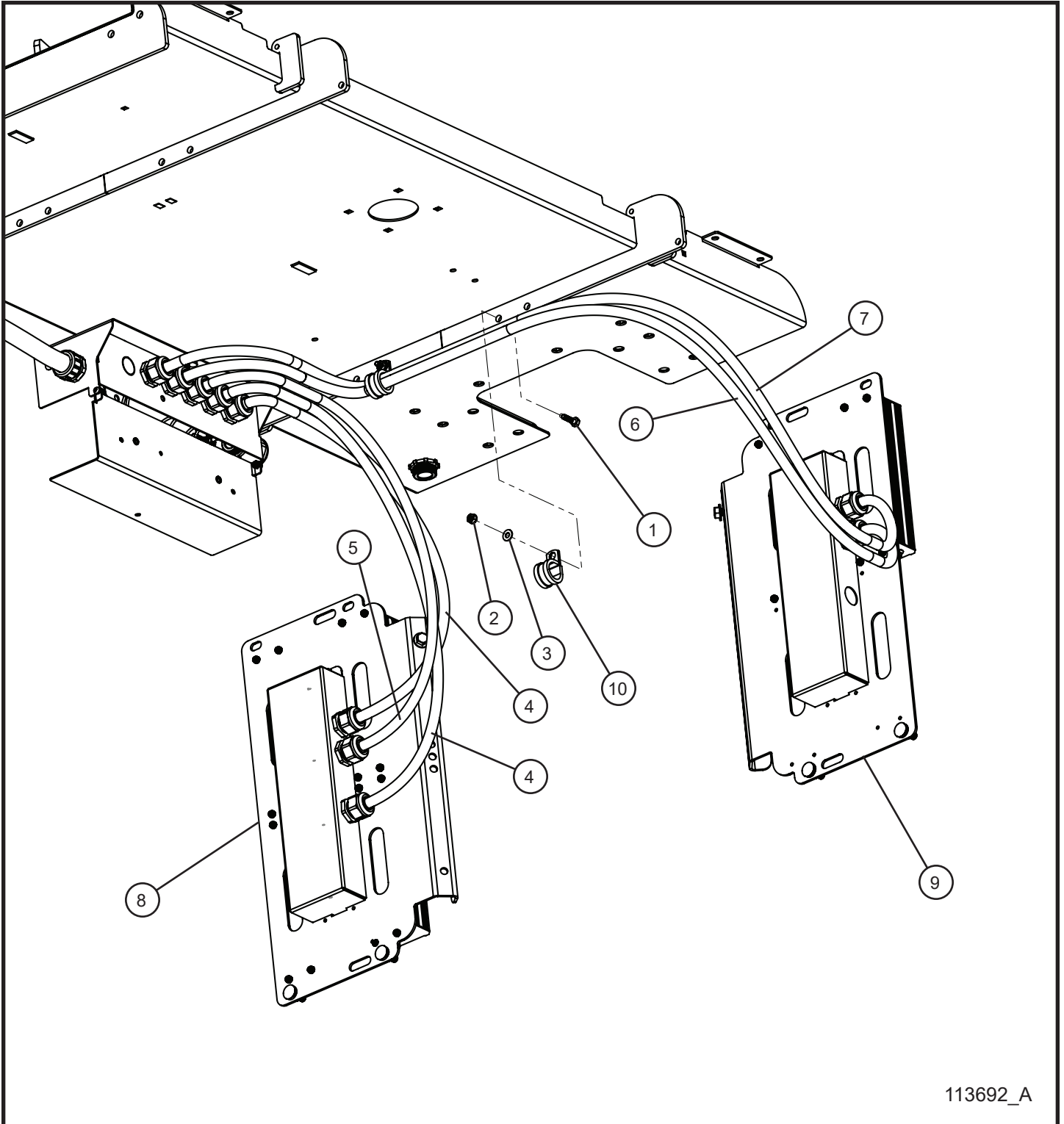

113692_A

4.13 - 6-Light COB LED Drivers Wiring Group

Item	Part No.	Part Description	Qty.
1	046015	1/4-20 x 1 HEX HEAD BOLT	2
2	044021	1/4-20 KEPS HEX NUT	2
3	047009	1/4 FLAT WASHER	2
4	113708	LED 1-4 DRIVERS MAXI-LITE AC CORD	2
5	113709	LED 1-4 DRIVERS MAXI-LITE DC CORD	1
6	113710	LED 5-6 DRIVERS MAXI-LITE DC CORD	1
7	113711	LED 5-6 DRIVERS MAXI-LITE AC CORD	1
8	111959	FOUR DRIVER LED LIGHTING ASSEMBLY	1
9	111472	TWO DRIVER LED LIGHTING ASSEMBLY	1
10	022083	#16 CUSHION CLAMP	2
NS	110094	WIRE SCHEMATIC DRIVER 5 THROUGH 6 MAXI-LITE	1
NS	117355	WIRE SCHEMATIC DRIVER 1 THROUGH 4 MAXI-LITE	1
NS	113625	WIRE SCHEMATIC 6 LED JUNCTION BOX MAXI-LITE	1

*NS - NOT SHOWN

4.14 - 4 COB LED Drivers Assembly Group

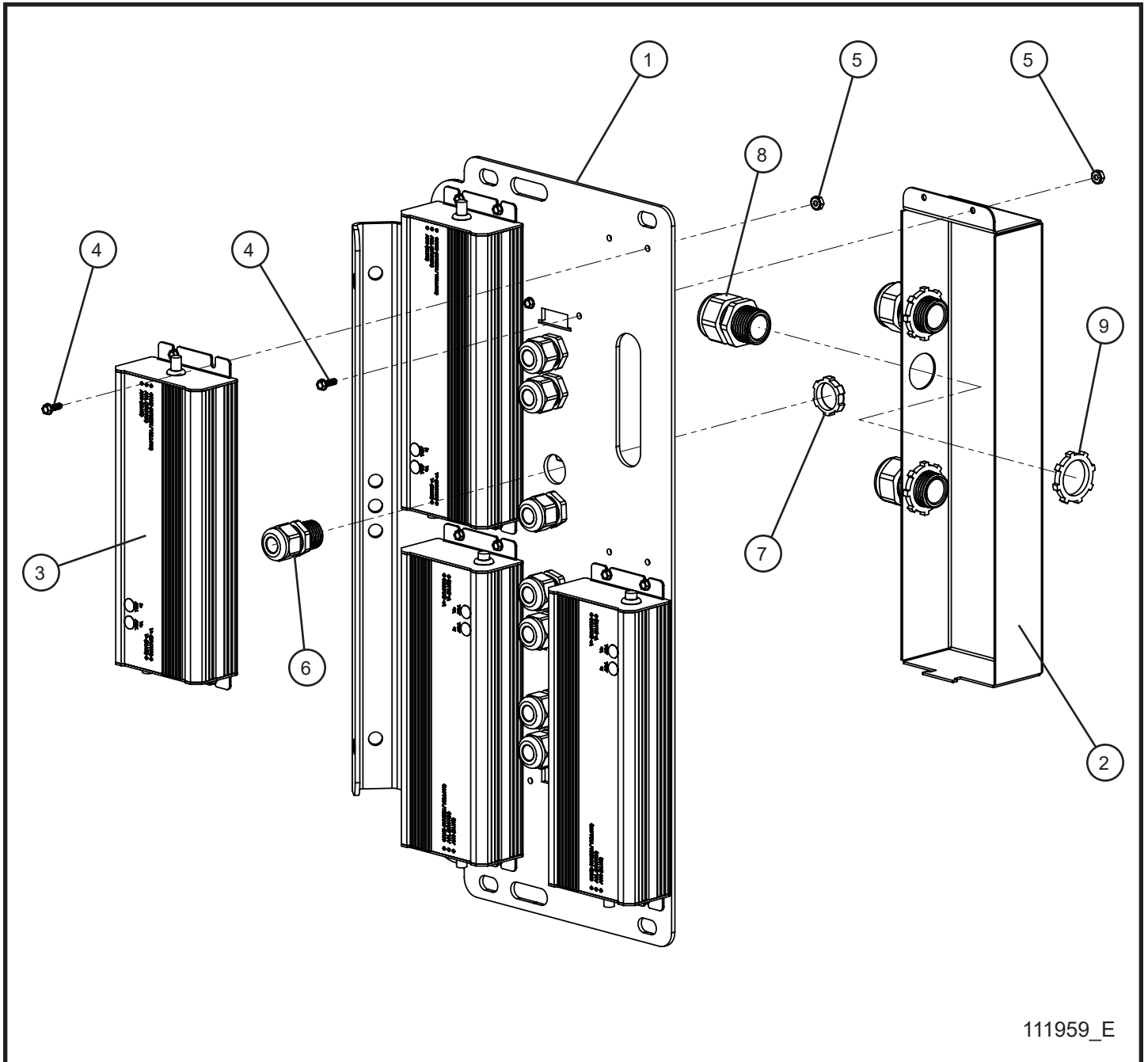

111959_E

4.14 - 4 COB LED Drivers Assembly Group

Item	Part No.	Part Description	Qty.
1	111465P	MOUNT PLATE LED DRIVER	1
2	111960P	LED DRIVER JUNCTION BOX	1
3	111449	CONSSIN HLG-320-54A LED DRIVER	4
4	041029	#8-32 x 1/2 HEX WASHER HEAD SCREW	18
5	044003	#8-32 KEPS NUT	18
6	105626	CORD GRIP 1/2 NYLON BLACK	8
7	022035	1/2 CORD GRIP NUT	8
8	105916	CORD GRIP NYLON 3/4	3
9	022036	3/4 CORD GRIP NUT	3
NS	111462	CONSSIN LED LIGHT AND DRIVER KIT	1

*NS - NOT SHOWN

4.15 - 2 COB LED Drivers Assembly Group

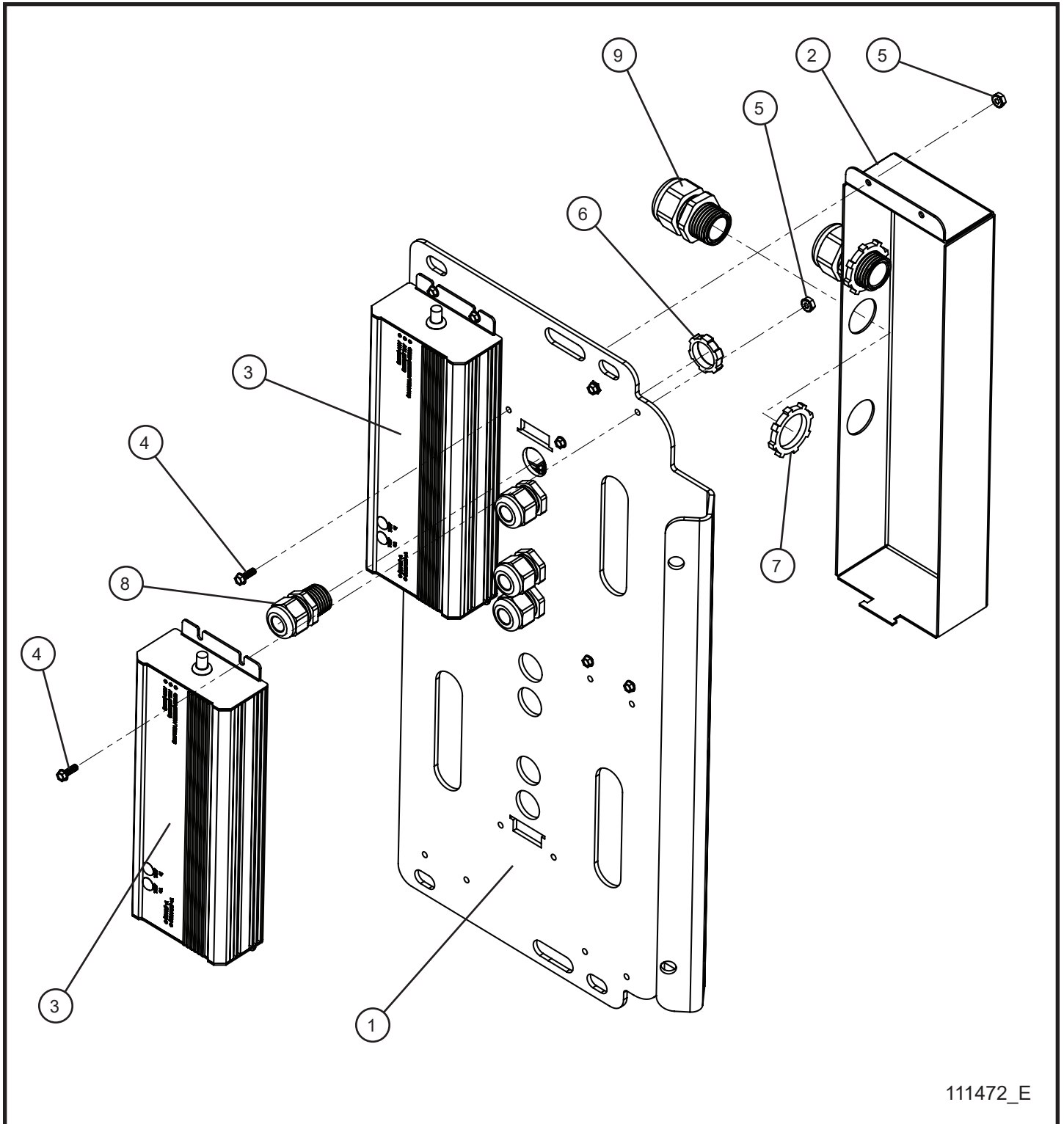

111472_E

4.15 - 2 COB LED Drivers Assembly Group

Item	Part No.	Part Description	Qty.
1	111465P	MOUNT PLATE LED DRIVER	1
2	111960P	LED DRIVER JUNCTION BOX	1
3	111449	CONSSIN HLG-320-54A LED DRIVER	2
4	041029	#8-32 x 1/2 HEX WASHER HEAD SCREW	10
5	044003	#8-32 KEPS NUT	10
6	022035	1/2 CORD GRIP NUT	4
7	022036	3/4 CORD GRIP NUT	2
8	105626	CORD GRIP 1/2 NYLON BLACK	4
9	105916	CORD GRIP NYLON 3/4	2
NS	111462	CONSSIN LED LIGHT AND DRIVER KIT (INCL. 111449 & 111451)	1

*NS - NOT SHOWN

4.16 - 4-Light SHO Lamp Holder Install Group

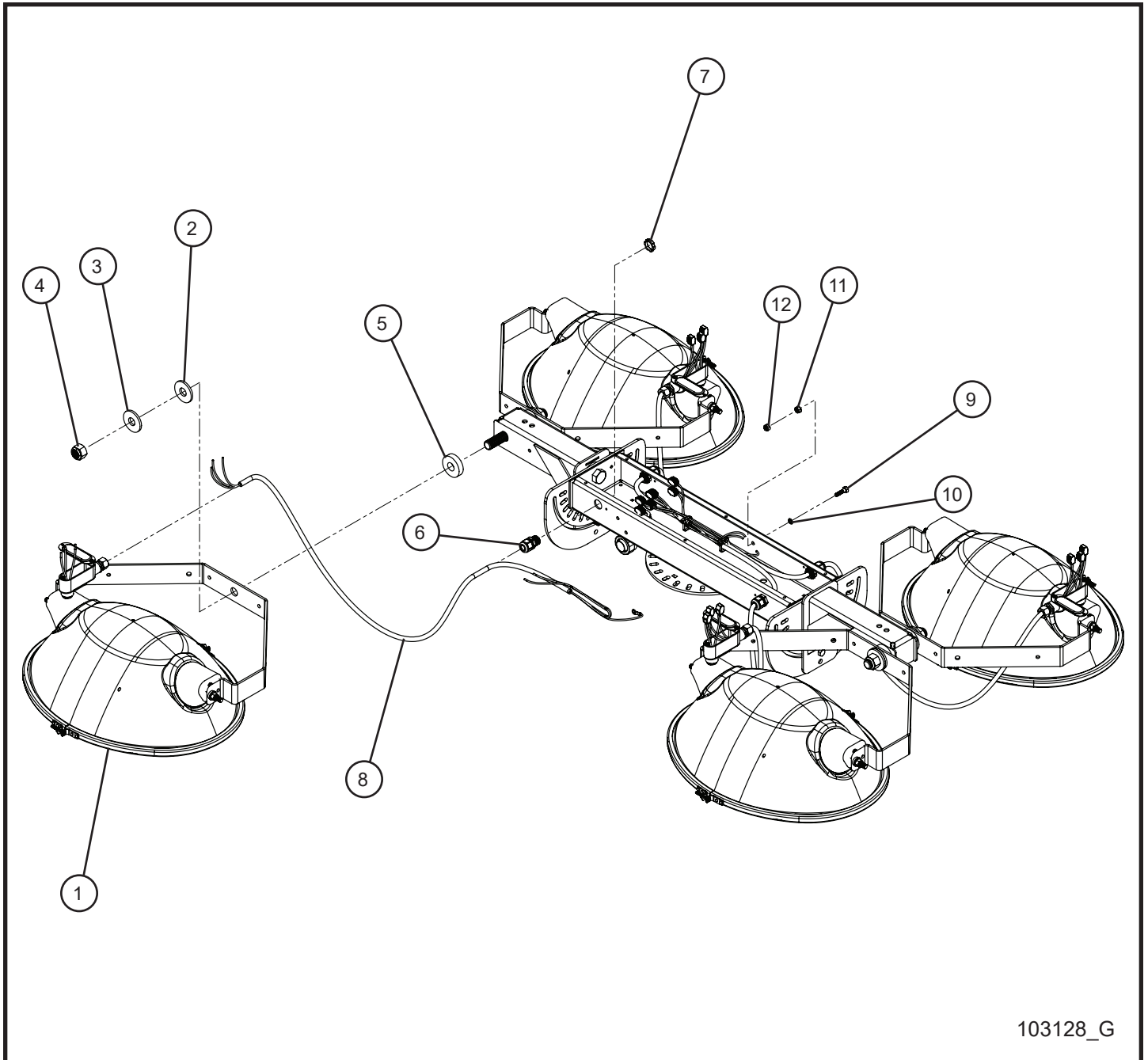

103128_G

4.16 - 4-Light SHO Lamp Holder Install Group

Item	Part No.	Part Description	Qty.
1	650147	LAMPHOLDER SHO LIGHT WITH NO LAMP	4
	650144	LAMPHOLDER SHO LIGHT WITH 1000W LAMP	4
	100633	LAMPHOLDER SHO LIGHT WITH 1250W LAMP	4
	105244	LAMPHOLDER CSA/UL SHO LIGHT WITH NO LAMP	4
2	650550	.785" x 2" HDPE WASHER	4
3	047035	3/4 FLAT WASHER	4
4	044058	3/4-10 NYLOCK HEX NUT	4
5	101813	.781 ID x 2 OD x 1/2 HDPE WASHER	4
6	105626	1/2 NYLON BLACK CORD GRIP	4
7	022035	1/2 CORD GRIP NUT	4
8	115000	16/3 HARD WIRED LAMP LEAD CORD	4
9	046015	1/4-20 x 1 HEX HEAD BOLT	1
10	043050	1/4 INTL TOOTHLOCK WASHER	1
11	044021	1/4-20 KEPS HEX NUT	1
12	044023	1/4-20 NYLOCK HEX NUT	1
NS	105294	SOLID WIRED LAMP SCHEMATIC	1

4.17 - 4-Light SHO Lamp Holder Disconnect Install Group

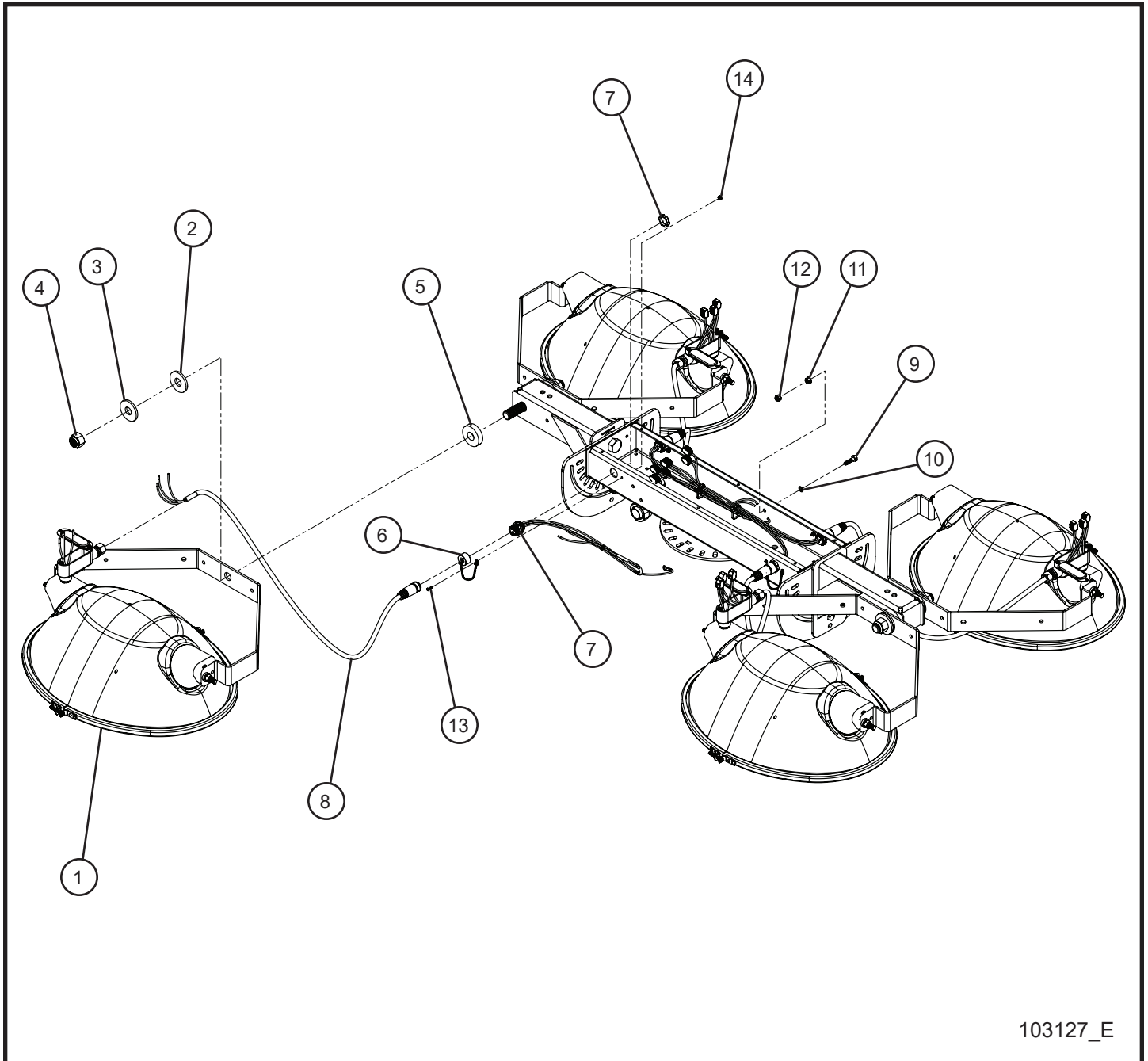

103127_E

4.17 - 4-Light SHO Lamp Holder Disconnect Install Group

Item	Part No.	Part Description	Qty.
1	650147	LAMPHOLDER SHO LIGHT WITH NO LAMP	4
	650144	LAMPHOLDER SHO LIGHT WITH 1000W LAMP	4
	100633	LAMPHOLDER SHO LIGHT WITH 1250W LAMP	4
	105244	LAMPHOLDER CSA/UL SHO LIGHT WITH NO LAMP	4
2	650550	.785" x 2" HDPE WASHER	4
3	047035	3/4 FLAT WASHER	4
4	044058	3/4-10 NYLOCK HEX NUT	4
5	101813	.781 ID x 2 OD x 1/2 HDPE WASHER	4
6	310413	LIGHT BAR QUICK DISCONNECT CAP	4
7	115001	HUBBEL FEMALE CONNECTOR CABLE	4
8	310434	HUBBEL MALE CONNECTOR CABLE	4
9	046015	1/4-20 x 1 HEX HEAD BOLT	1
10	043050	1/4 INTL TOOTHLOCK WASHER	1
11	044021	1/4-20 KEPS HEX NUT	1
12	044023	1/4-20 NYLOCK HEX NUT	1
13	100029	#6-32 x 1/2 PH-ROUND HEAD MACHINE SCREW	4
14	044004	#6-32 KEPS HEX NUT	4
NS	105295	QUICK DISCONNECT WIRED LAMP SCHEMATIC	1

4.18 - 6-Light SHO Lamp Holder Install Group

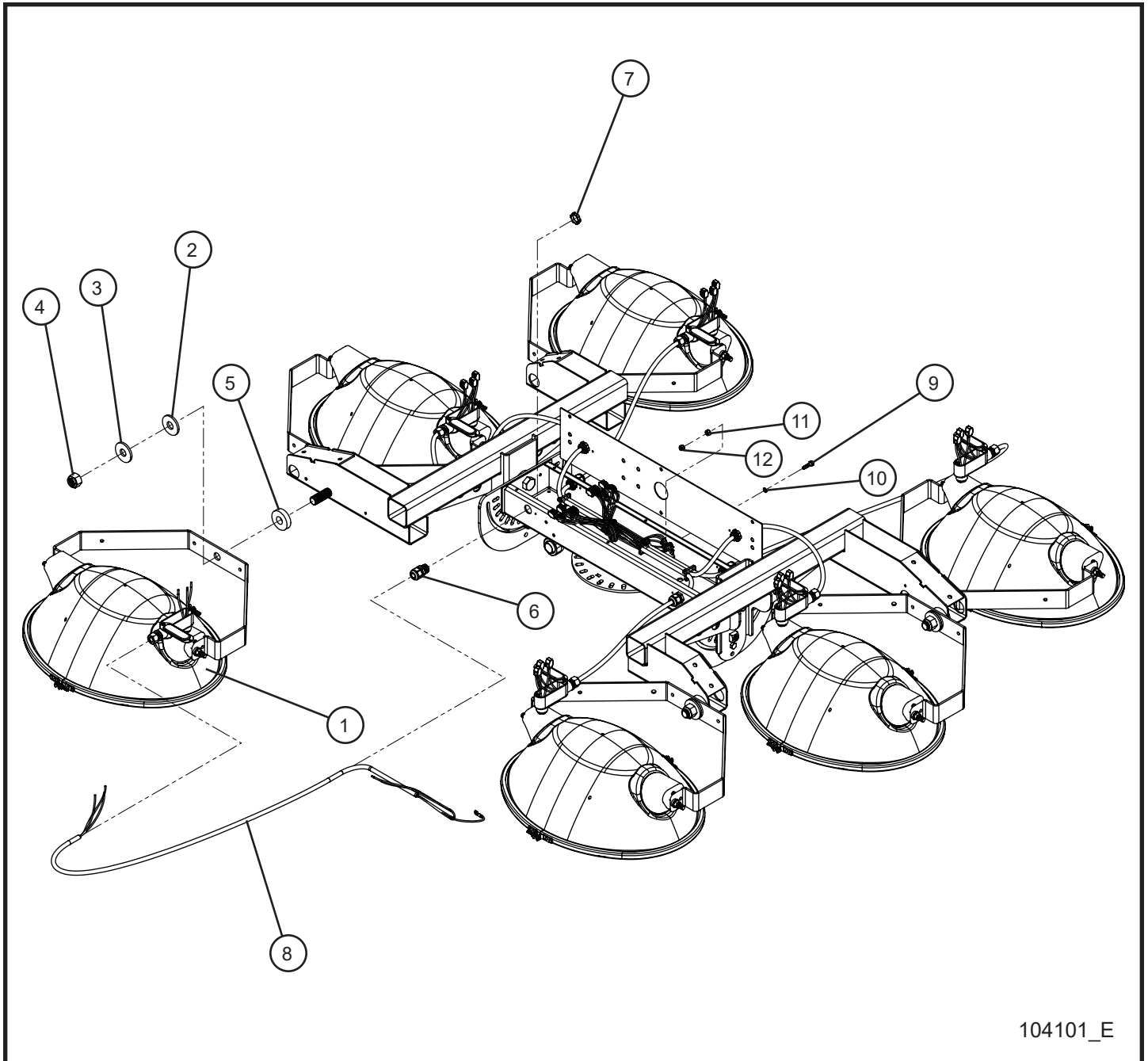

104101_E

4.18 - 6-Light SHO Lamp Holder Install Group

Item	Part No.	Part Description	Qty.
1	650147	LAMPHOLDER SHO LIGHT WITH NO LAMP	6
	650144	LAMPHOLDER SHO LIGHT WITH 1000W LAMP	6
	100633	LAMPHOLDER SHO LIGHT WITH 1250W LAMP	6
	105244	LAMPHOLDER CSA/UL SHO LIGHT WITH NO LAMP	6
2	650550	.785" x 2" HDPE WASHER	6
3	047035	3/4 FLAT WASHER	6
4	044058	3/4-10 NYLOCK HEX NUT	6
5	101813	.781 ID x 2 OD x 1/2 HDPE WASHER	6
6	105626	1/2 CORD GRIP	6
7	022035	1/2 CORD GRIP NUT	6
8	115000	16/3 HARD WIRED LAMP LEAD CORD	6
9	046015	1/4-20 x 1 HEX HEAD BOLT	1
10	043050	1/4 INTL TOOTHLOCK WASHER	1
11	044021	1/4-20 KEPS HEX NUT	1
12	044023	1/4-20 NYLOCK HEX NUT	1
NS	105294	SOLID WIRED LAMP SCHEMATIC	1

4.19 - 6-Light SHO Lamp Holder Disconnect Install Group

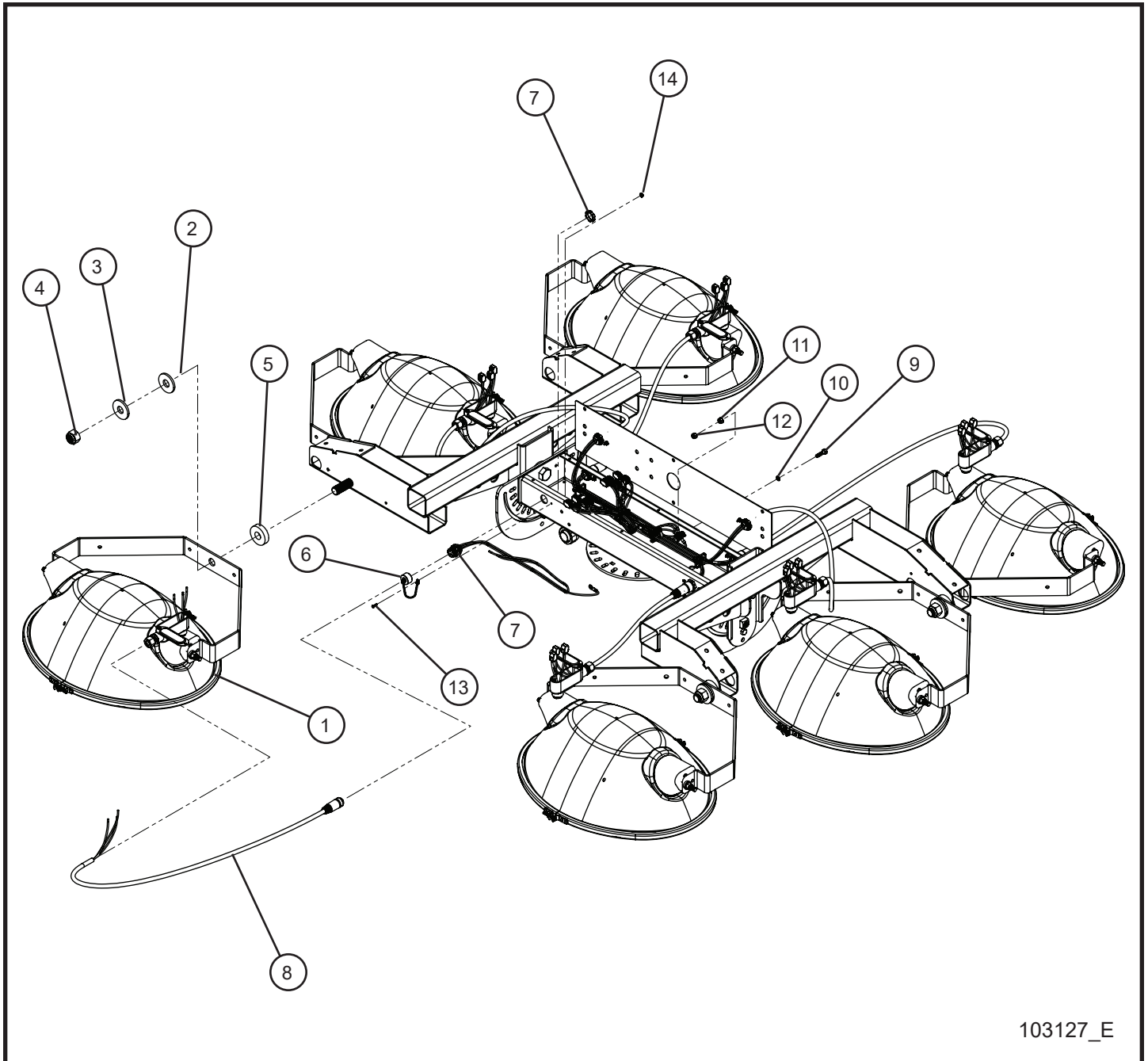

103127_E

4.19 - 6-Light SHO Lamp Holder Disconnect Install Group

Item	Part No.	Part Description	Qty.
1	650147	LAMPHOLDER SHO LIGHT WITH NO LAMP	6
	650144	LAMPHOLDER SHO LIGHT WITH 1000W LAMP	6
	100633	LAMPHOLDER SHO LIGHT WITH 1250W LAMP	6
	105244	LAMPHOLDER CSA/UL SHO LIGHT WITH NO LAMP	6
2	650550	.785" x 2" HDPE WASHER	6
3	047035	3/4 FLAT WASHER	6
4	044058	3/4-10 NYLOCK HEX NUT	6
5	101813	.781 ID x 2 OD x 1/2 HDPE WASHER	6
6	310413	LIGHT BAR QUICK DISCONNECT CAP	6
7	115001	HUBBEL FEMALE CONNECTOR CABLE	6
8	310434	HUBBEL MALE CONNECTOR CABLE	6
9	046015	1/4-20 x 1 HEX HEAD BOLT	1
10	043050	1/4 INTL TOOTHLOCK WASHER	1
11	044021	1/4-20 KEPS HEX NUT	1
12	044023	1/4-20 NYLOCK HEX NUT	1
13	100029	#6-32 x 1/2 PH-ROUND HEAD MACHINE SCREW	6
14	044004	#6-32 KEPS HEX NUT	6
NS	105295	QUICK DISCONNECT WIRED LAMP SCHEMATIC	1

4.20 - SHO Lamp Holder Assembly Group

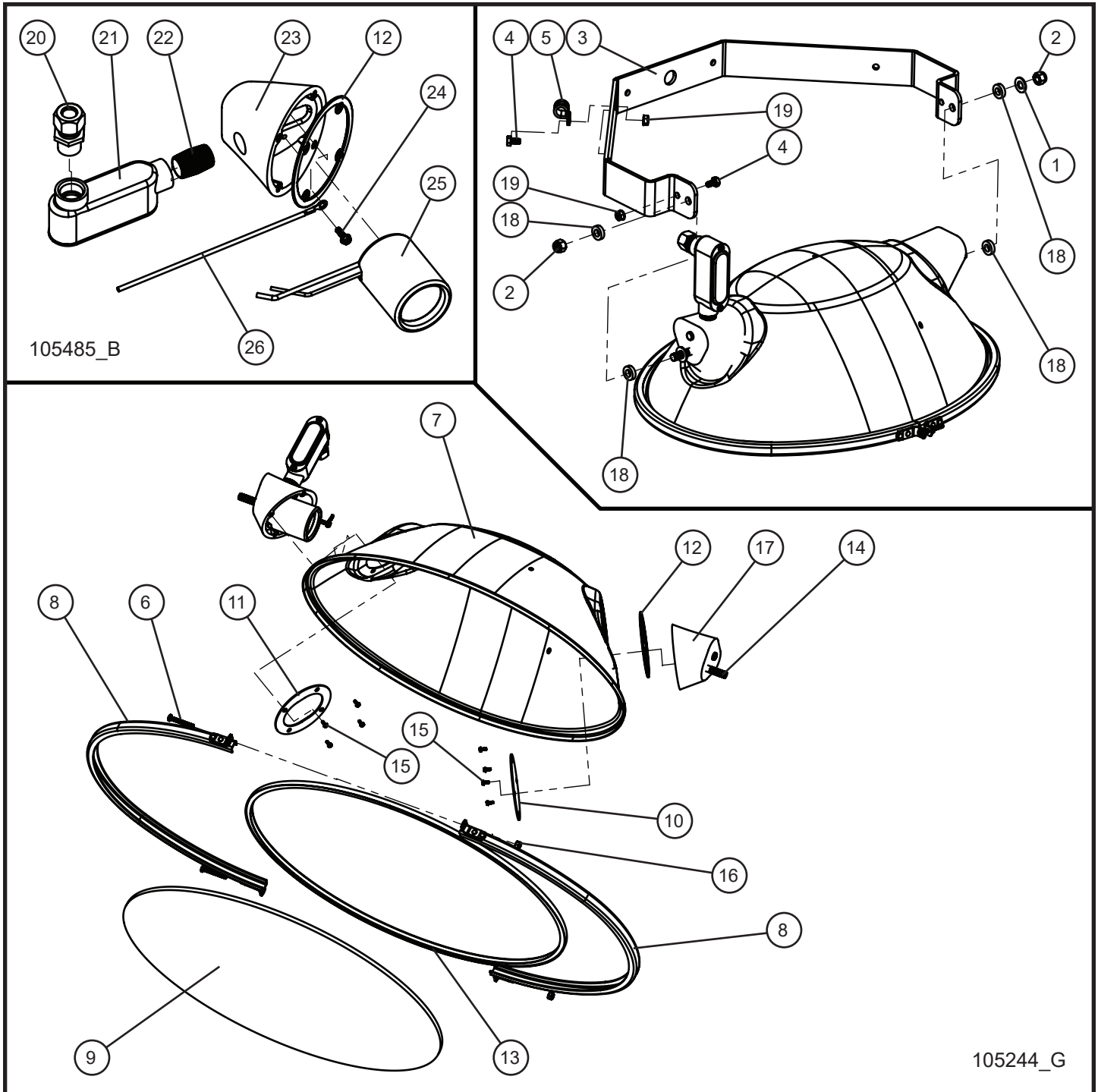

4.20 - SHO Lamp Holder Assembly Group

Item	Part No.	Part Description	Qty.
--	105244	COMPLETE LAMP ASSEMBLY	1
1	047016	3/8 FLAT WASHER	2
2	044037	3/8-24 NYLOCK HEX NUT	2
3	660130	YOKE MOUNT SHO LAMP	1
4	046005	1/4-20 x 1/2 HEX HEAD BOLT	2
5	022018	#8 CUSH CLAMP	1
6	041040	#10-24 x 1 1/2 PH-ROUND HEAD MACHINE SCREW	2
7	610201	REFLECTOR	1
8	610202	LENS CHANNEL SET SHO LIGHT	2
9	610203	GLASS LENS	1
10	610207	INTERIOR COVER PLATE WITHOUT HOLE	1
11	610208	INTERIOR COVER PLATE WITH HOLE	1
12	610213	GASKET SOCKET END CAP	2
13	610217	SILICONE GASKET	1
14	045142	3/8-24 x 3/8-16 x 2 STUD	2
15	041028	#10-24 x 1/2 HEX WASHER HEAD	8
16	044019	#10-24 NYLOCK HEX NUT	2
17	610206	CASTING END SHO	1
18	047019	NYLON BUSHING 3/4 OD x .385 ID	4
19	044021	1/4-20 KEPS HEX NUT	2
20	510007	1/2 CORD GRIP	1
21	610214	ELBOW 1/2 SLB SHO ENTRANCE	1
22	610215	1/2 NPT NIPPLE	1
23	610205	SOCKET CASTING END SHO	1
24	041257	#10-32 x 3/8 SL-HEX WASHER HEAD MS GRND	1
25	610212	CERAMIC SOCKET	1
26	610219	GROUND WIRE LAMPHOLDER SHO ENTRANCE	1

4.21 - SHO Lamp Holder Bulb Options

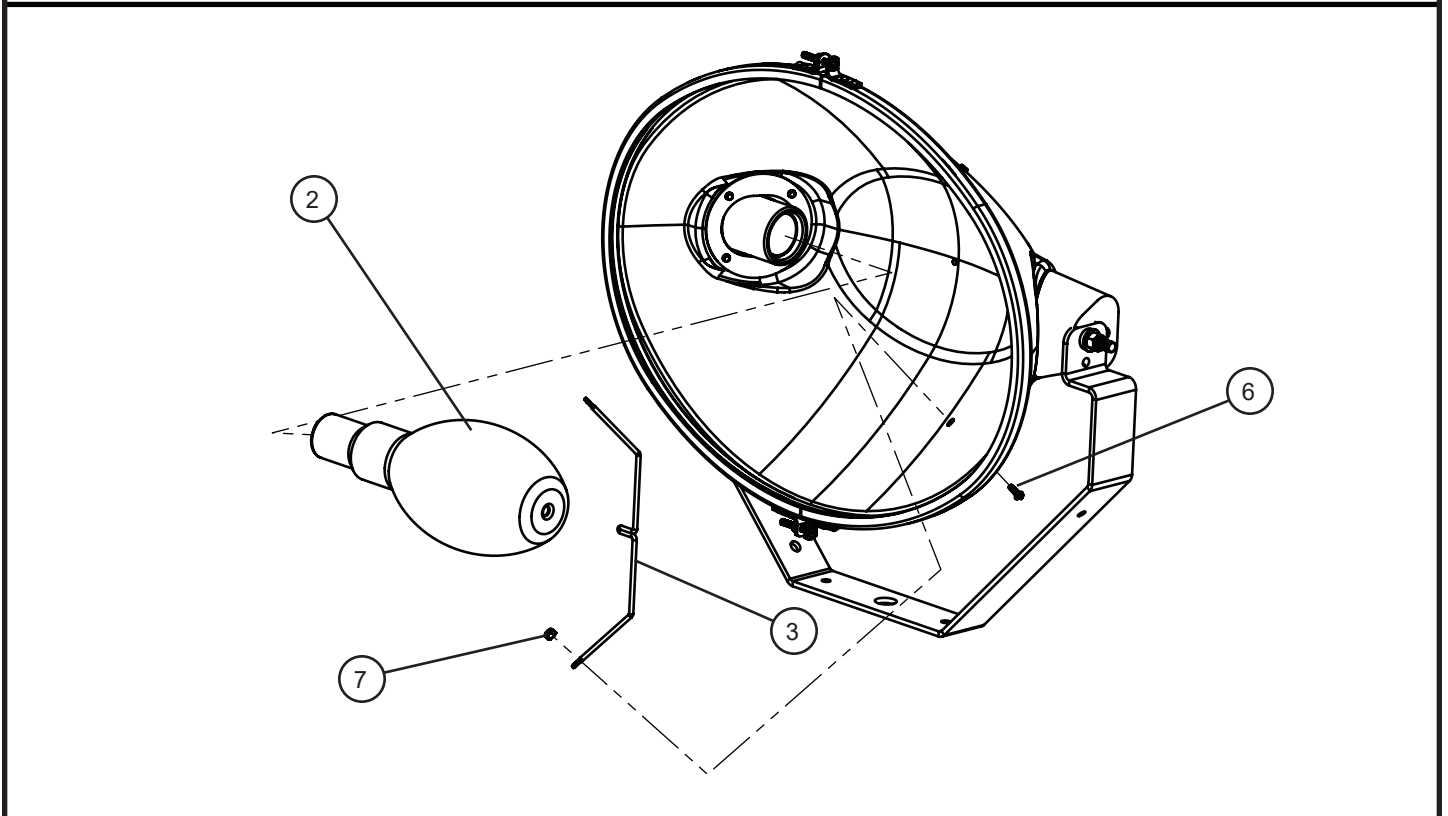
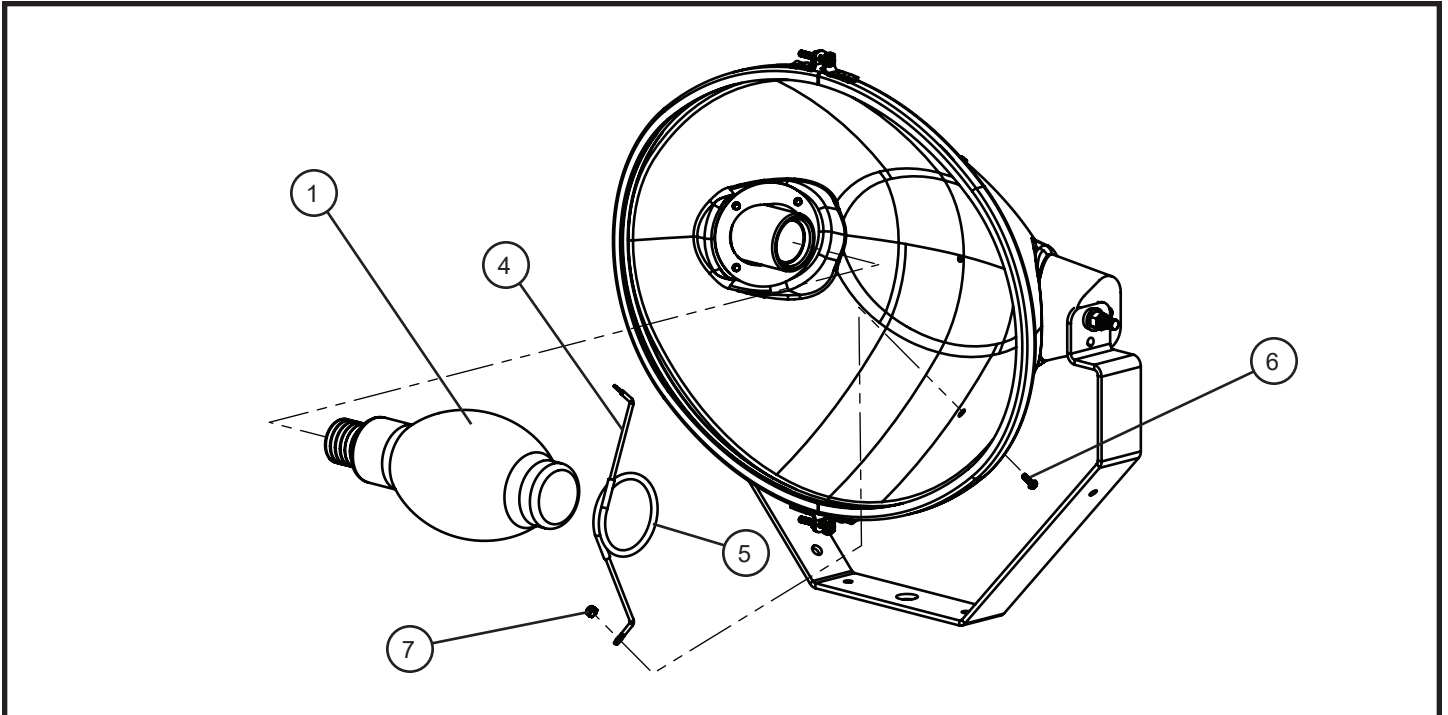

4.21 - SHO Lamp Holder Bulb Options

Item	Part No.	Part Description	Qty.
1	610221	LAMP 1250W BT37 (MH)	1
	610211	LAMP 1000W BT37 (MH)	1
2	610218	LAMP 1000W ED37 (HPS)	1
3	650250	TIP SUPPORT HPS 1000W	1
4	610209	SHO LAMP SUPPORT TIP	1
5	610210	12" LAMP SUPPORT FIBERGLASS TUBE	1
6	041200	#8-32 x 1/2 HEX WASHER HEAD	2
7	044013	#8-32 NYLOCK HEX NUT	2

4.22 - 4-Light COB LED Lamp Install Group

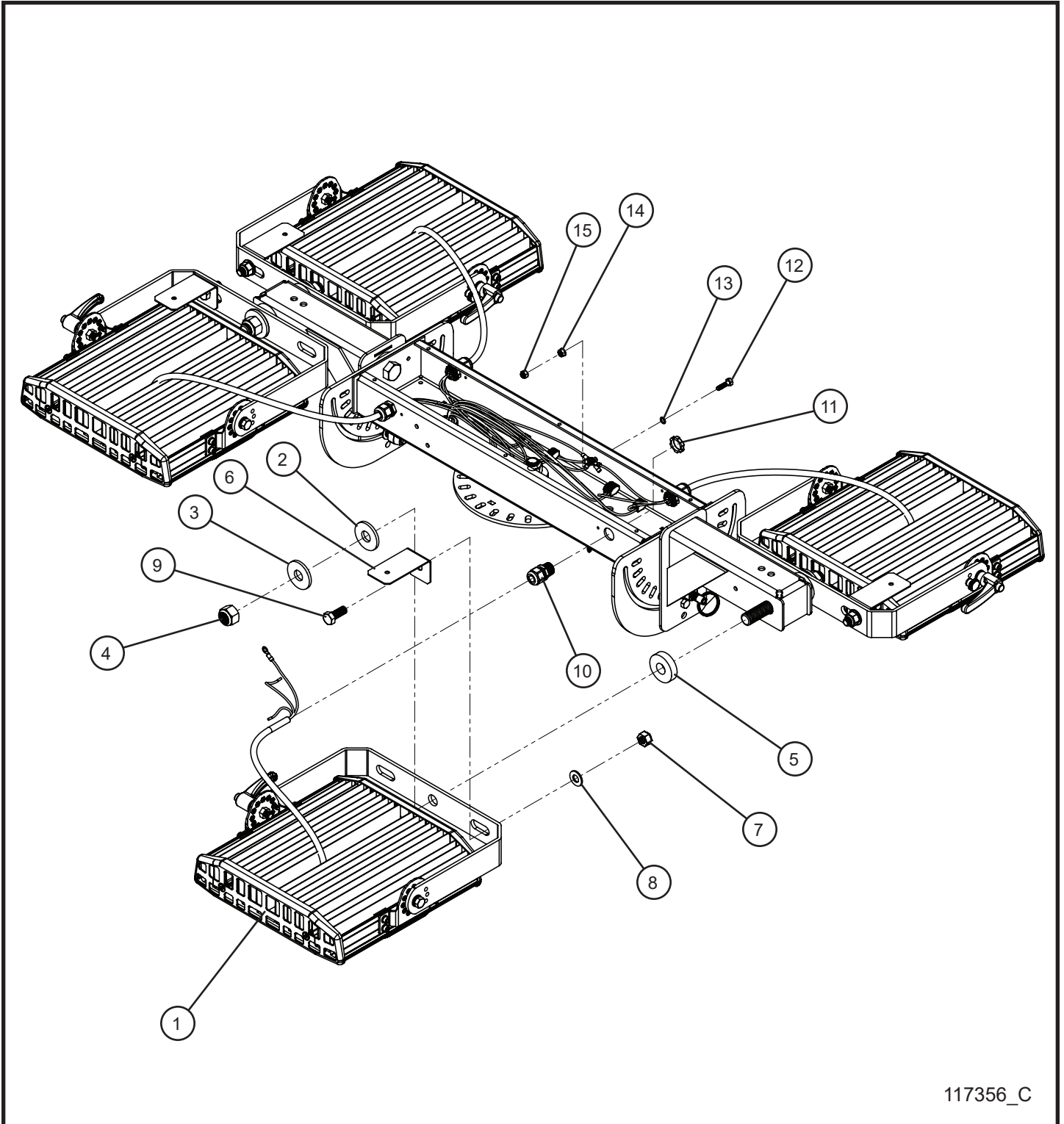

117356_C

4.22 - 4-Light LED Lamp Install Group

Item	Part No.	Part Description	Qty.
1	114075	CONSSIN KUEM2-320 LED LIGHT	4
2	650550	.785" x 2" HDPE WASHER	4
3	047035	3/4 FLAT WASHER PL	4
4	044058	3/4-10 NYLOCK HEX NUT PL	4
5	101813	.781 ID x 2 OD x 1/2 HDPE WASHER	4
6	111975P	LED CONSSIN CSA STOP	4
7	044048	1/2-13 NYLOCK HEX NUT PL	4
8	047025	1/2 FLAT WASHER PL	4
9	046180	1/2-13 x 1 1/4 HEX HEAD CS GR5 PL	4
10	105626	1/2 CORD GRIP	4
11	022035	1/2 CORD GRIP NUT	4
12	046015	1/4-20 x 1 HEX HEAD BOLT	1
13	043050	1/4 INTL TOOTHLOCK WASHER	1
14	044021	1/4-20 KEPS HEX NUT	1
15	044023	1/4-20 NYLOCK HEX NUT	1
NS	117357	4 LIGHT LED LIGHT BAR SCHEMATIC	1
NS	111462	CONSSIN LED LIGHT AND DRIVER KIT	1

4.23 - 6-Light COB LED Lamp Install Group

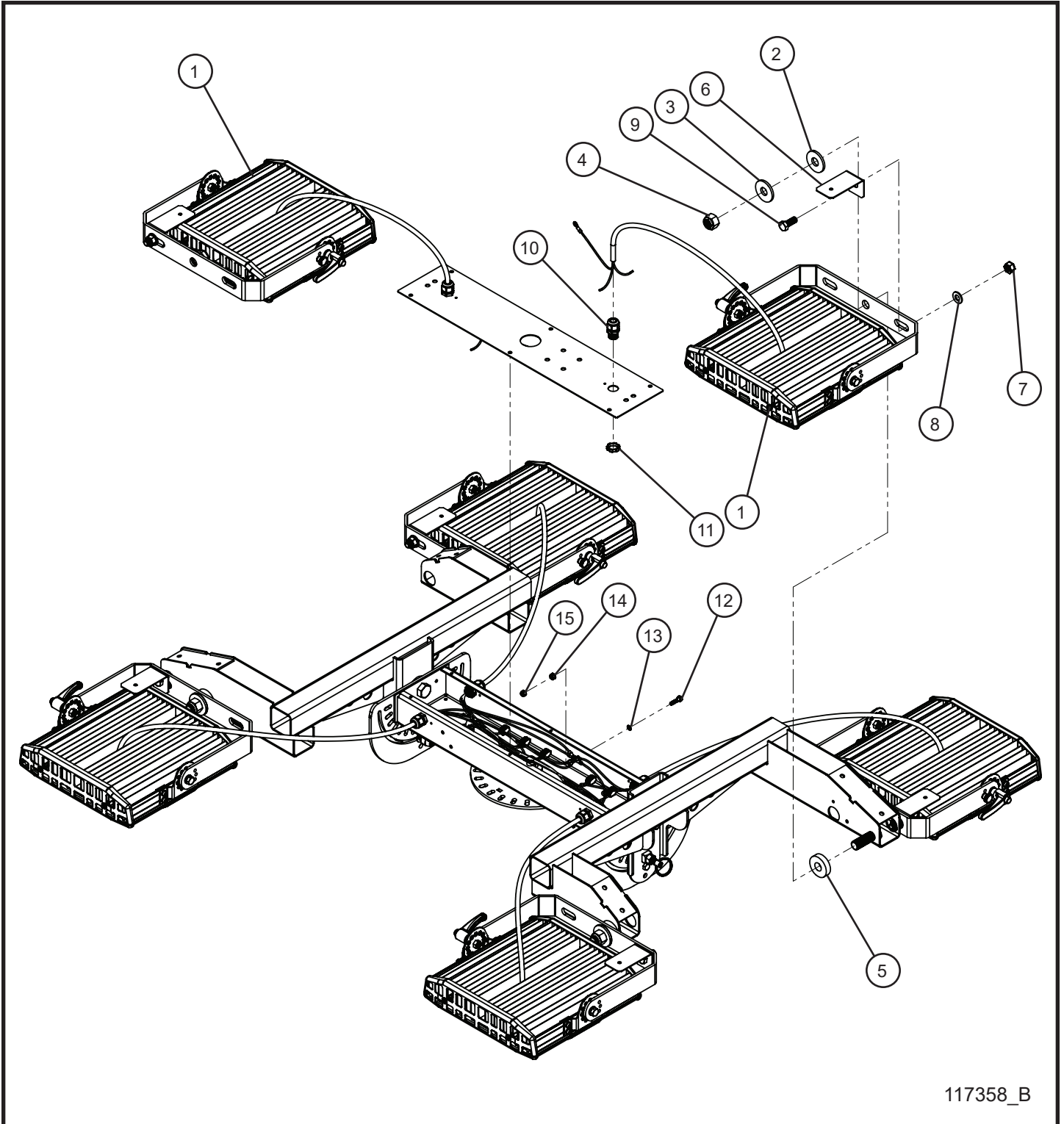

117358_B

4.23 - 6-Light LED Lamp Install Group

Item	Part No.	Part Description	Qty.
1	114075	CONSSIN KUEM2-320 LED LIGHT	6
2	650550	.785" x 2" HDPE WASHER	6
3	047035	3/4 FLAT WASHER PL	6
4	044058	3/4-10 NYLOCK HEX NUT PL	6
5	101813	.781 ID x 2 OD x 1/2 HDPE WASHER	6
6	111975P	LED CONSSIN CSA STOP	6
7	044048	1/2-13 NYLOCK HEX NUT PL	6
8	047025	1/2 FLAT WASHER PL	6
9	046180	1/2-13 x 1 1/4 HEX HEAD CS GR5 PL	6
10	105626	1/2 CORD GRIP	6
11	022035	1/2 CORD GRIP NUT	6
12	046015	1/4-20 x 1 HEX HEAD BOLT	1
13	043050	1/4 INTL TOOTHLOCK WASHER	1
14	044021	1/4-20 KEPS HEX NUT	1
15	044023	1/4-20 NYLOCK HEX NUT	1
NS	117359	6 LIGHT LED LIGHT BAR SCHEMATIC	1
NS	111462	CONSSIN LED LIGHT AND DRIVER KIT	1

4.24 - COB LED Lamp

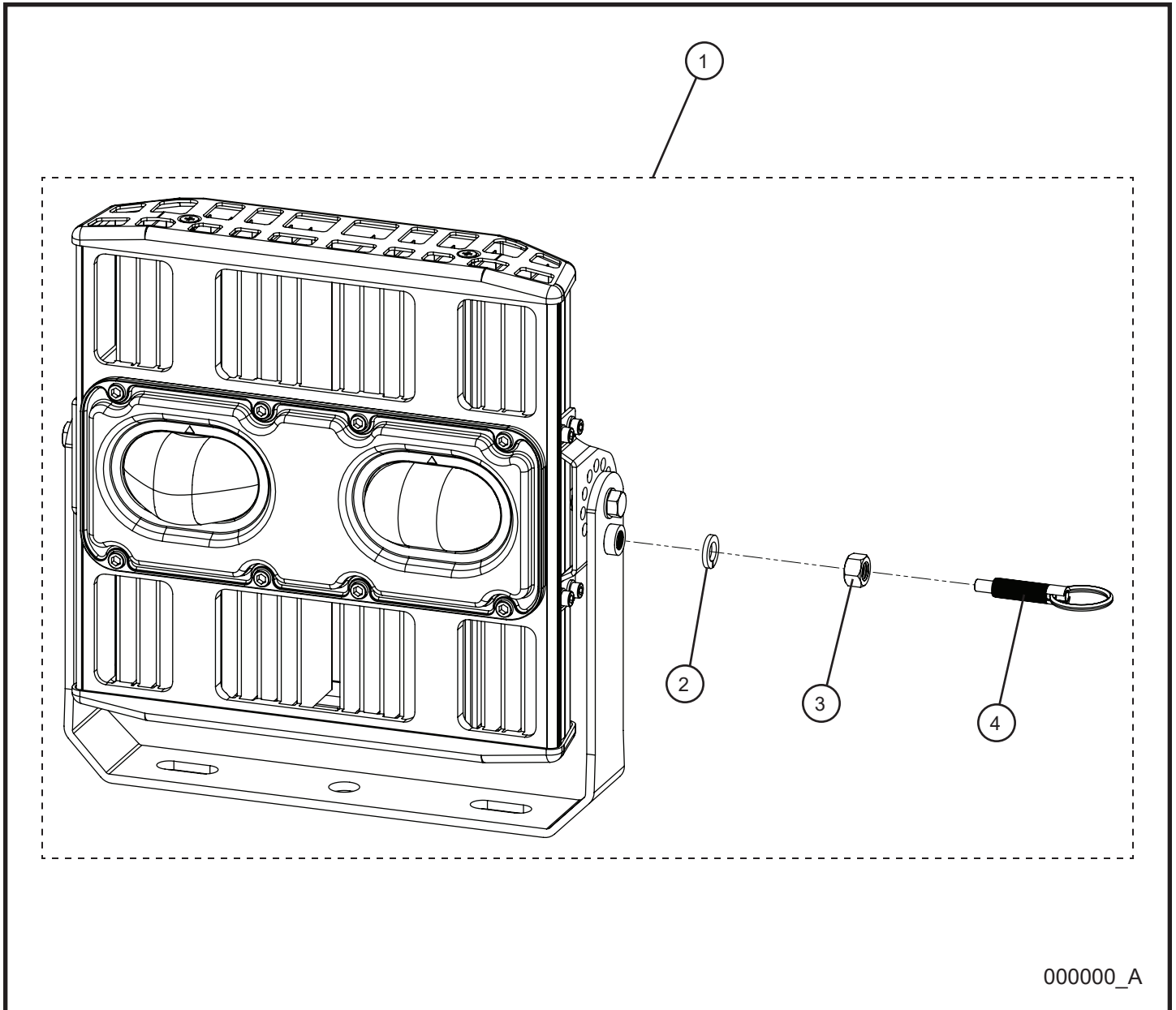

000000_A

4.24 - LED Lamp

Item	Part No.	Part Description	Qty.
1	114075	CONSSIN KUEM2-320 LED LIGHT	1
2	043085	1/2 SPLITLOCK WASHER	1
3	044045	1/2 HEX NUT	1
4	100148	SPRING LOCK 1/2-13 UNC x 1.4	1
NS	114104	YOKE, BRACKETS, AND HARDWARE CONSSIN KIT	1
NS	111462	CONSSIN LED LIGHT AND DRIVER KIT	1

4.25 - COB LED Lamp Diffuser

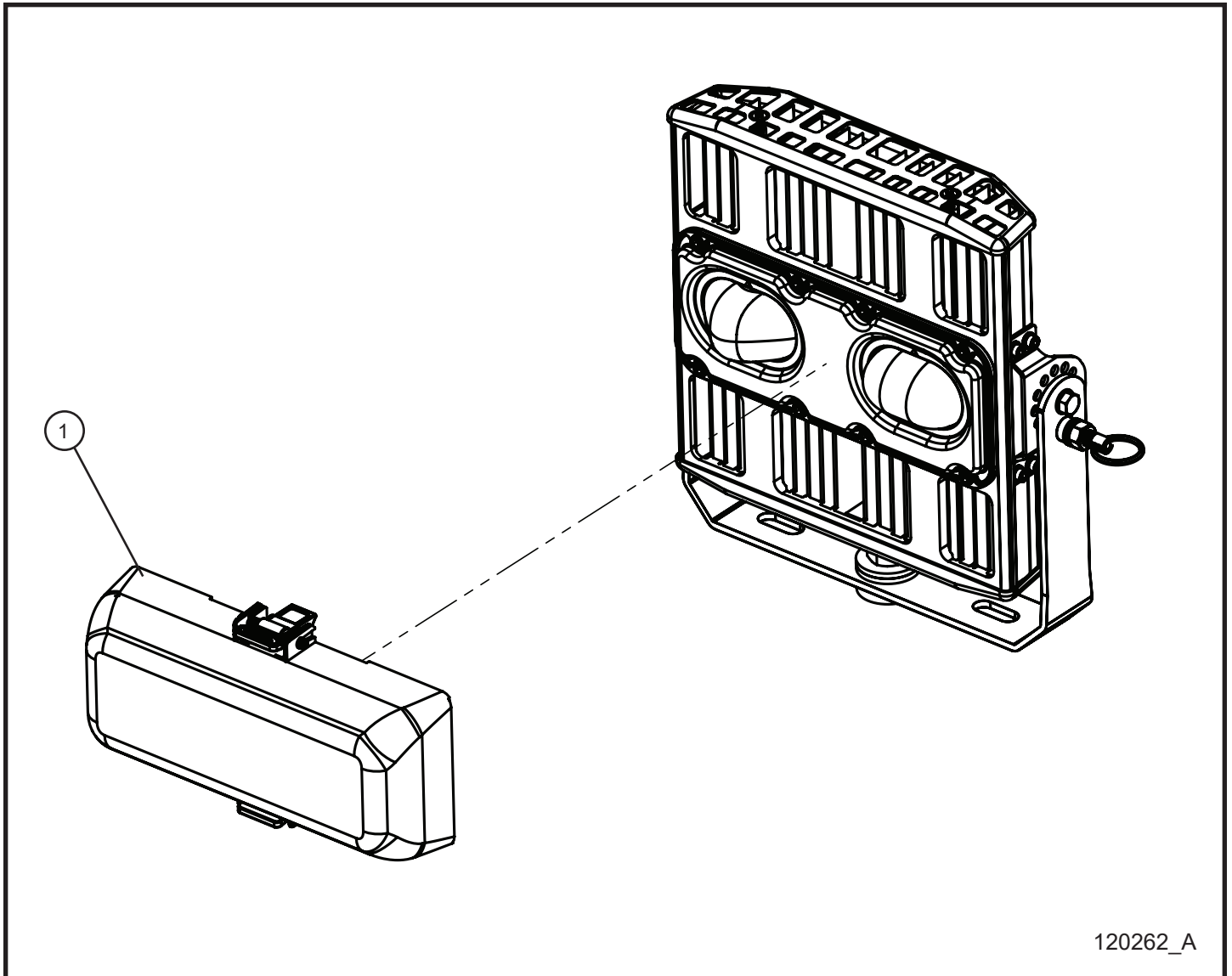

4.25 - COB LED Lamp Diffuser

Item	Part No.	Part Description	Qty.
1	118419	DIFFUSER COVER LIGHT LED COB 320W	1

*NS - NOT SHOWN

4.26 - 4-Light SMD LED Lamp Install Group

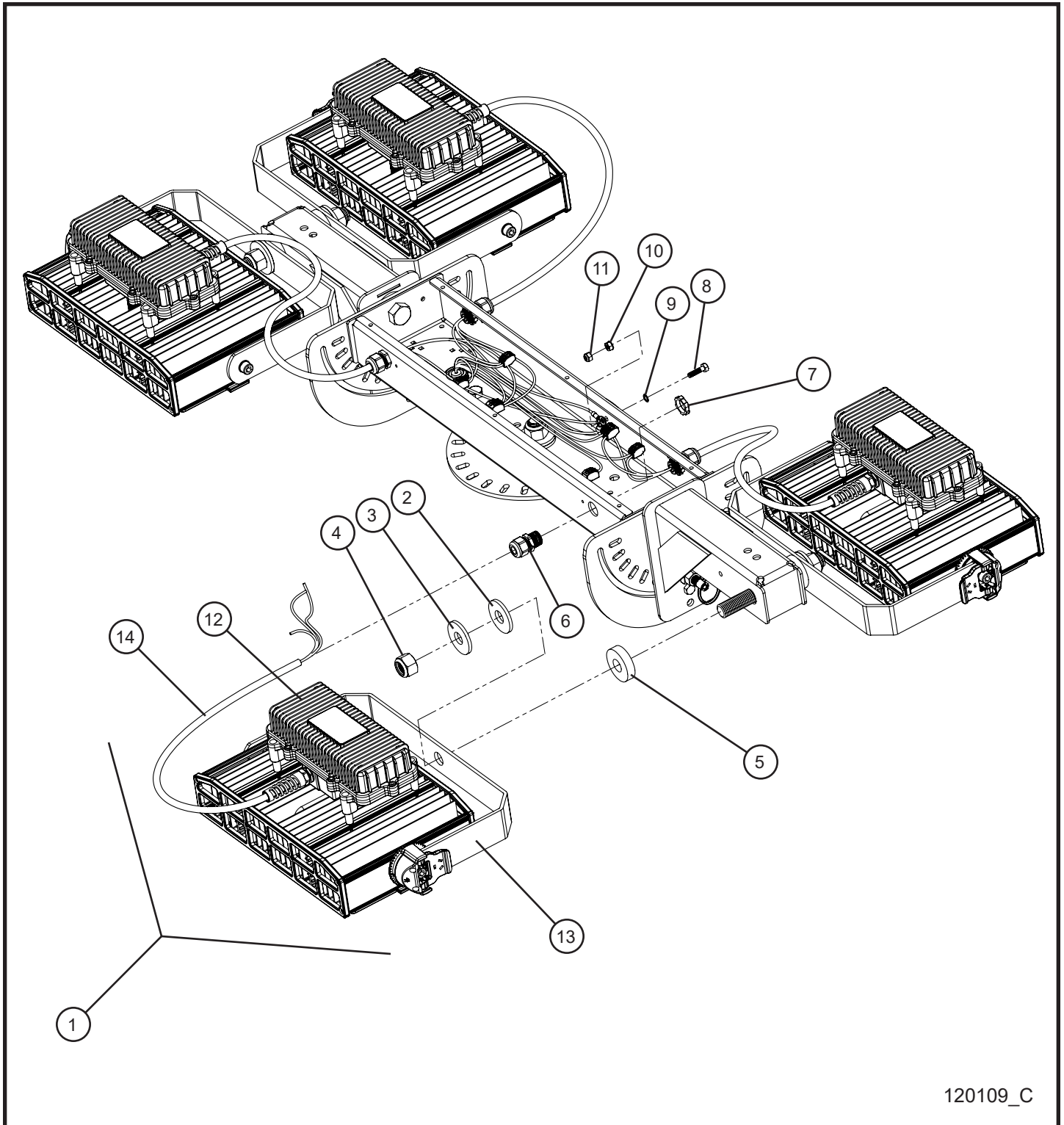

120109_C

4.26 - 4-Light LED Lamp Install Group

Item	Part No.	Part Description	Qty.
1	123200	350W SMD KUM1S-350 LED ASSEMBLY	4
2	650550	.785" x 2" HDPE WASHER	4
3	047035	3/4 FLAT WASHER PL	4
4	044058	3/4-10 NYLOCK HEX NUT PL	4
5	101813	.781 ID x 2 OD x 1/2 HDPE WASHER	4
6	105626	1/2 CORD GRIP	4
7	022035	1/2 CORD GRIP NUT	4
8	046015	1/4-20 x 1 HEX HEAD BOLT	1
9	043050	1/4 INTL TOOTHLOCK WASHER	1
10	044021	1/4-20 KEPS HEX NUT	1
11	044023	1/4-20 NYLOCK HEX NUT	1
12	123198	DRIVER KUM1S-350 SMD LED 350W	1
13	123197	YOKE & HARDWARE KIT KUM1S-350	1
14	122483	AC POWER CORD KUH2S-250 AND KUH2S-350	1
NS	105292	SCHEMATIC 4 LIGHT 16/8 CORD 1P OR 208V 3P	1

4.27 - 6-Light SMD LED Lamp Install Group

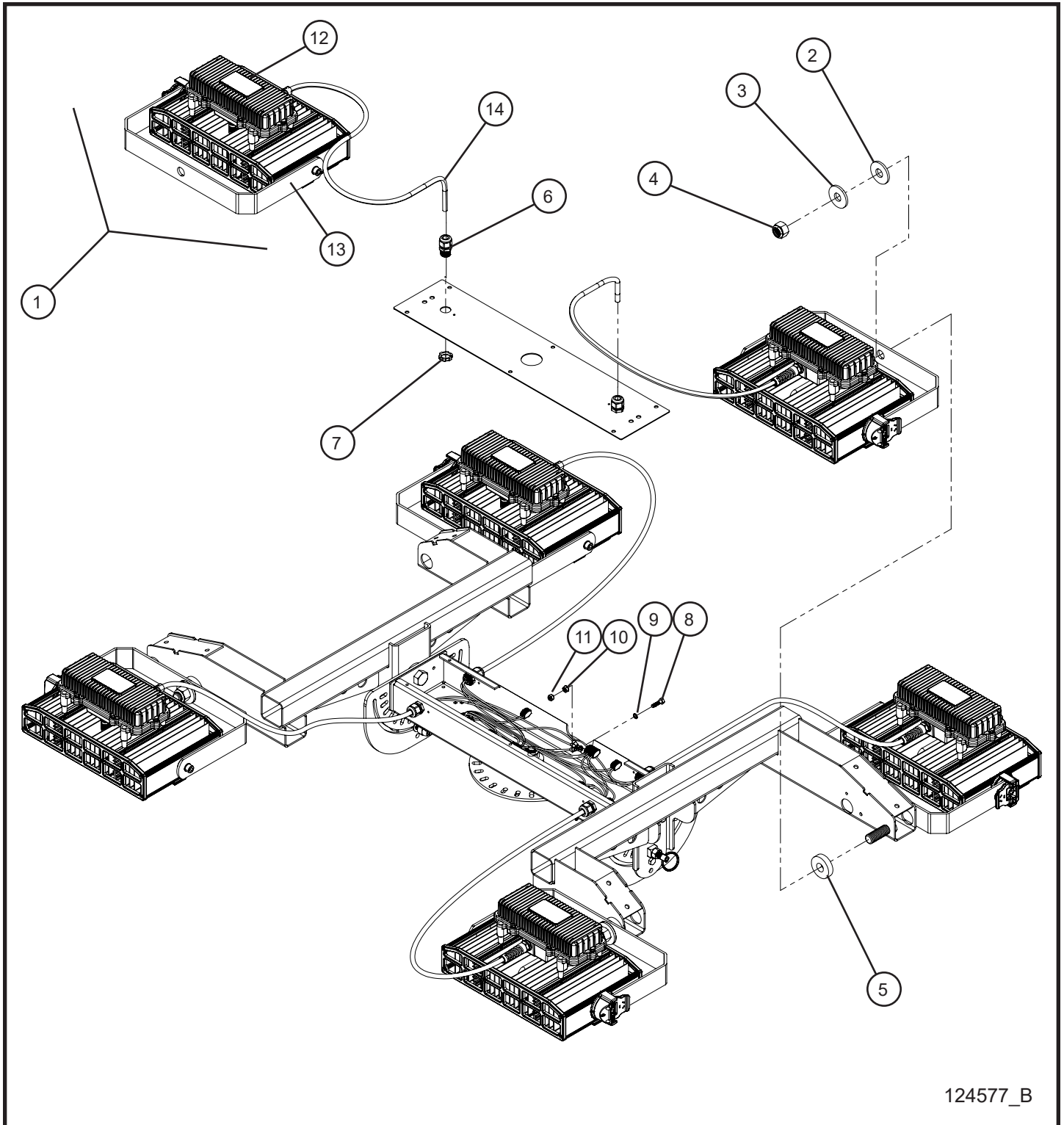

124577_B

4.27 - 6-Light LED Lamp Install Group

Item	Part No.	Part Description	Qty.
1	123200	LIGHT LED 350W SMD KUM1S-350	6
2	650550	.785" x 2" HDPE WASHER	6
3	047035	3/4 FLAT WASHER PL	6
4	044058	3/4-10 NYLOCK HEX NUT PL	6
5	101813	.781 ID x 2 OD x 1/2 HDPE WASHER	6
6	105626	1/2 CORD GRIP	6
7	022035	1/2 CORD GRIP NUT	6
8	046015	1/4-20 x 1 HEX HEAD BOLT	1
9	043050	1/4 INTL TOOTHLOCK WASHER	1
10	044021	1/4-20 KEPS HEX NUT	1
11	044023	1/4-20 NYLOCK HEX NUT	1
12	123198	DRIVER KUM1S-350 SMD LED 350W	1
13	123197	YOKE & HARDWARE KIT KUM1S-350	1
14	122483	AC POWER CORD KUH2S-250 AND KUH2S-350	1
NS	124584	SCHEMATIC LIGHT BAR 6 LIGHT 16/10 CORD 1P OR 208V 3P	1

4.28 - SMD LED Lamp Diffuser

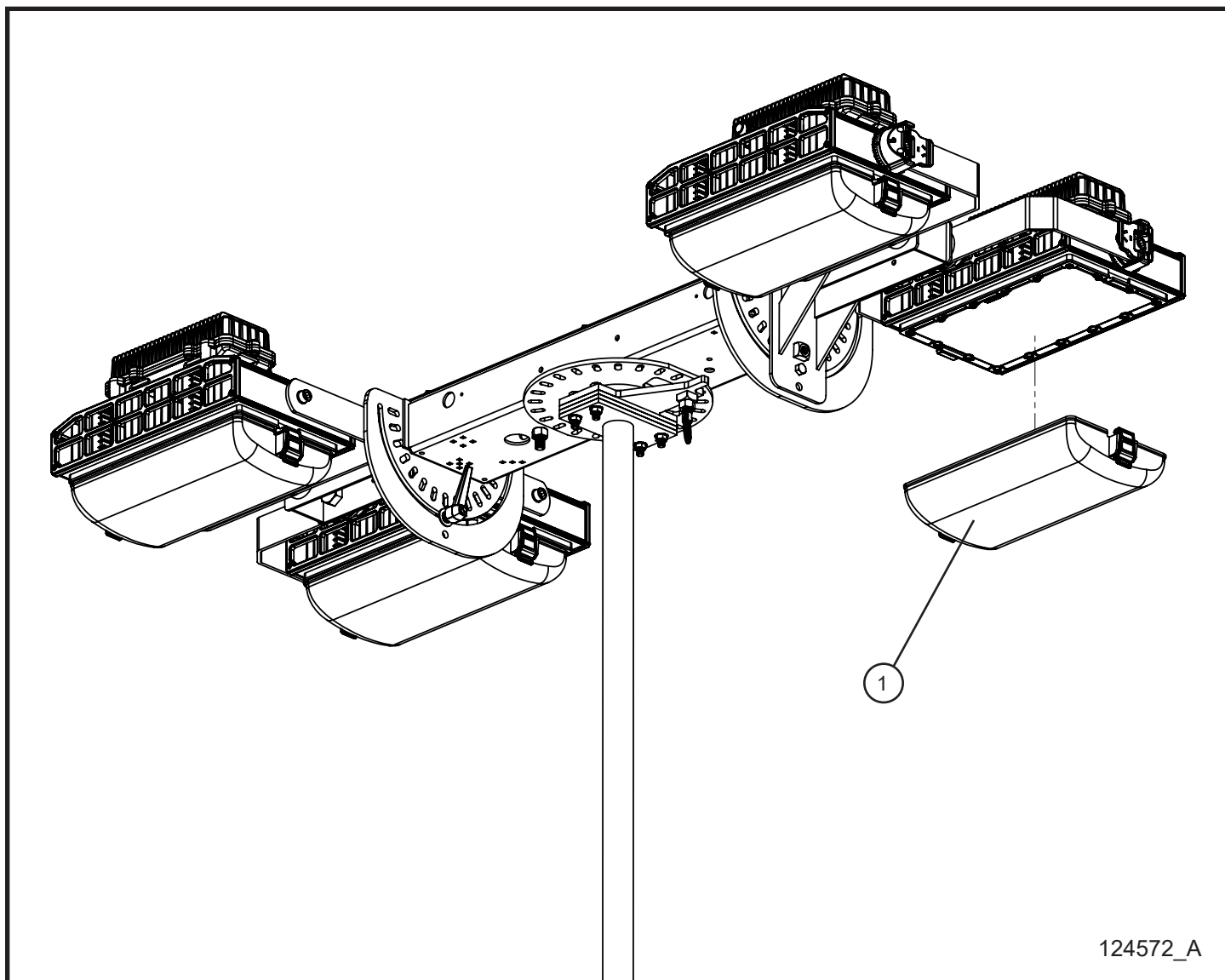

4.28 - SMD LED Lamp Diffuser

Item	Part No.	Part Description	Qty.
1	123199	DIFFUSER LED LIGHT KUM1S-350	4/6
	125226	DIFFUSER AMBER LED LIGHT KUM1S-350	4/6

5.1 - Control Box Install Group

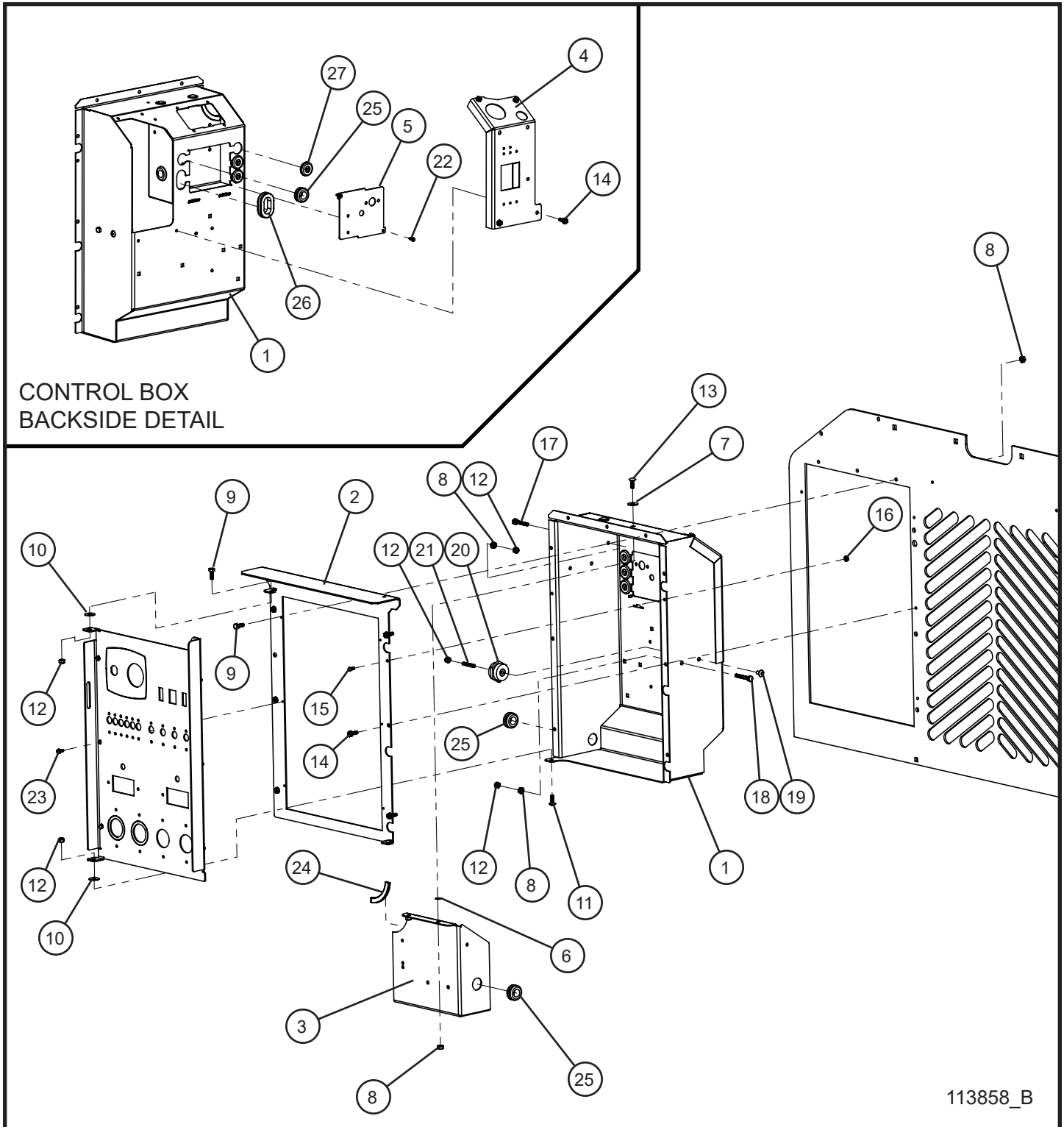

113858_B

5.1 - Control Box Install Group

Item	Part No.	Part Description	Qty.
1	111222P	MAXI-LITE COMPONENT BOX SHELL	1
2	113480P	MAXI-LITE COMPONENT BOX DOOR MOUNT	1
3	111227P	MAXI-LITE COMPONENT BOX DIVIDER PANEL	1
4	112434P	MAXI-LITE MAIN BREAKER PANEL	1
5	111228P	MAXI-LITE COMPONENT BOX BACK COVER	1
6	101701	1/4 PUSH NUT	2
7	047010	5/16 FLAT WASHER	2
8	044021	1/4-20 KEPS HEX NUT	7
9	046010	1/4-20 x 3/4 HEX HEAD BOLT	4
10	711036	3/8 NYLON WASHER 7/8 OD x 11/32 ID	2
11	041050	1/4-20 x 3/4 PH-TRUSS HEAD MACHINE SCREW	3
12	044023	1/4-20 NYLON HEX NUT	7
13	053006	1/4-20 x 3/4 CARRIAGE BOLT	2
14	041070	1/4-20 x 3/4 SL-HEX WASHER HEAD MACHINE SCREW	10
15	041021	#10-24 x 1/2 PH-ROUND HEAD MACHINE SCREW	10
16	044016	#10-24 KEPS HEX NUT	2
17	046016	1/4-20 x 1-1/4 HEX HEAD BOLT	1
18	046029	1/4-20 x 1-3/4 HEX HEAD BOLT	1
19	122452	1/4-20 X 1/2 HEX SERRATED FLANGE BOLT W/ THREAD LOCK	1
20	106318	1/4-20, 1-1/4" LOW VOLTAGE INSULATOR	1
21	122454	1/4-20 X 1-1/2 STUD W/ THREAD LOCK	1
22	041029	#8-32 x 1/2 HEX WASHER HEAD MACHINE SCREW	2
23	041031	#10-24 x 1/2 HEX HEAD MACHINE SCREW	6
24	030053	5/64 x 7/16 x 2 7/8 TRIMLOCK	1
25	330463	11/16 ID x 1 OD GROMMET	3
26	650542	1 1/4 ID x 1 1/2 OD GROMMET	1
27	100859	7/8 ID x 1 1/4 OD WEBBED GROMMET	3

5.2 - Control Box Door

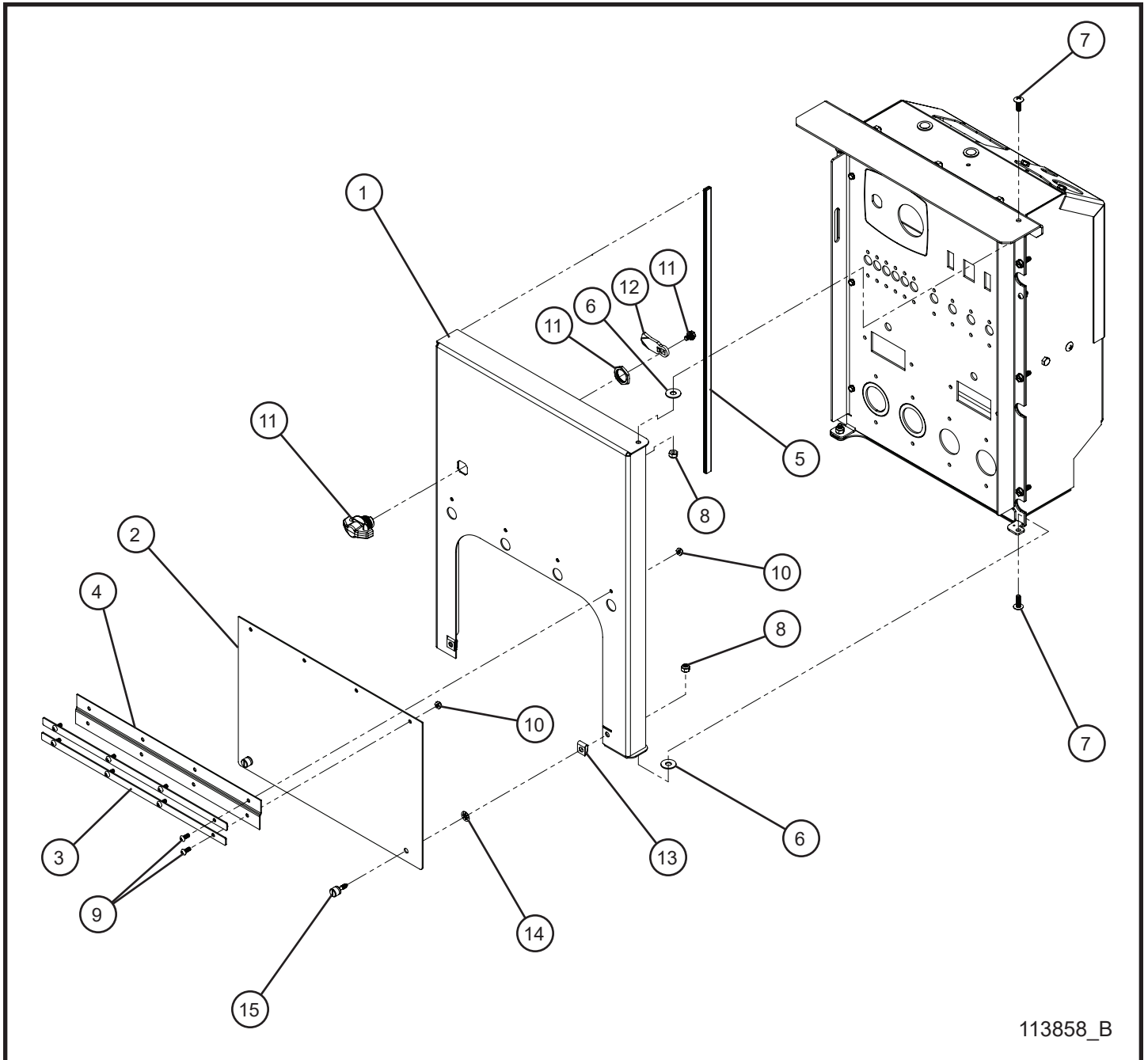

113858_B

5.2 - Control Box Door

Item	Part No.	Part Description	Qty.
1	111226P	MAXI-LITE COMPONENT BOX DOOR PANEL	1
2	112431P	MAXI-LITE COMPONENT BOX DOOR FLAP	1
3	112433P	MAXI-LITE COMPONENT BOX HINGE STRAP	2
4	115115	HINGE	1
5	030053	5/64 x 7/16 x 20 TRIMLOCK	1
6	711036	3/8 NYLON WASHER 7/8 OD x 11/32 ID	2
7	041050	1/4-20 x 3/4 PH-TRUSS HEAD MACHINE SCREW	3
8	044023	1/4-20 NYLOCK HEX NUT	7
9	041021	#10-24 x 1/2 PH-ROUND HEAD MACHINE SCREW	10
10	044018	#10-24 NYLOCK HEX NUT	8
11	111481	PADLOCKABLE BLACK WINGKNOB	1
12	111482	LATCH CAM STRAIGHT	1
13	045216	1/4-20 TINNERMAN NUT	1
14	115243	RETAINER PUSH ON	2
15	115244	FAST THREAD KNURLED KNOB	2

5.3 - Auxiliary 208V 3PH Outlet Box

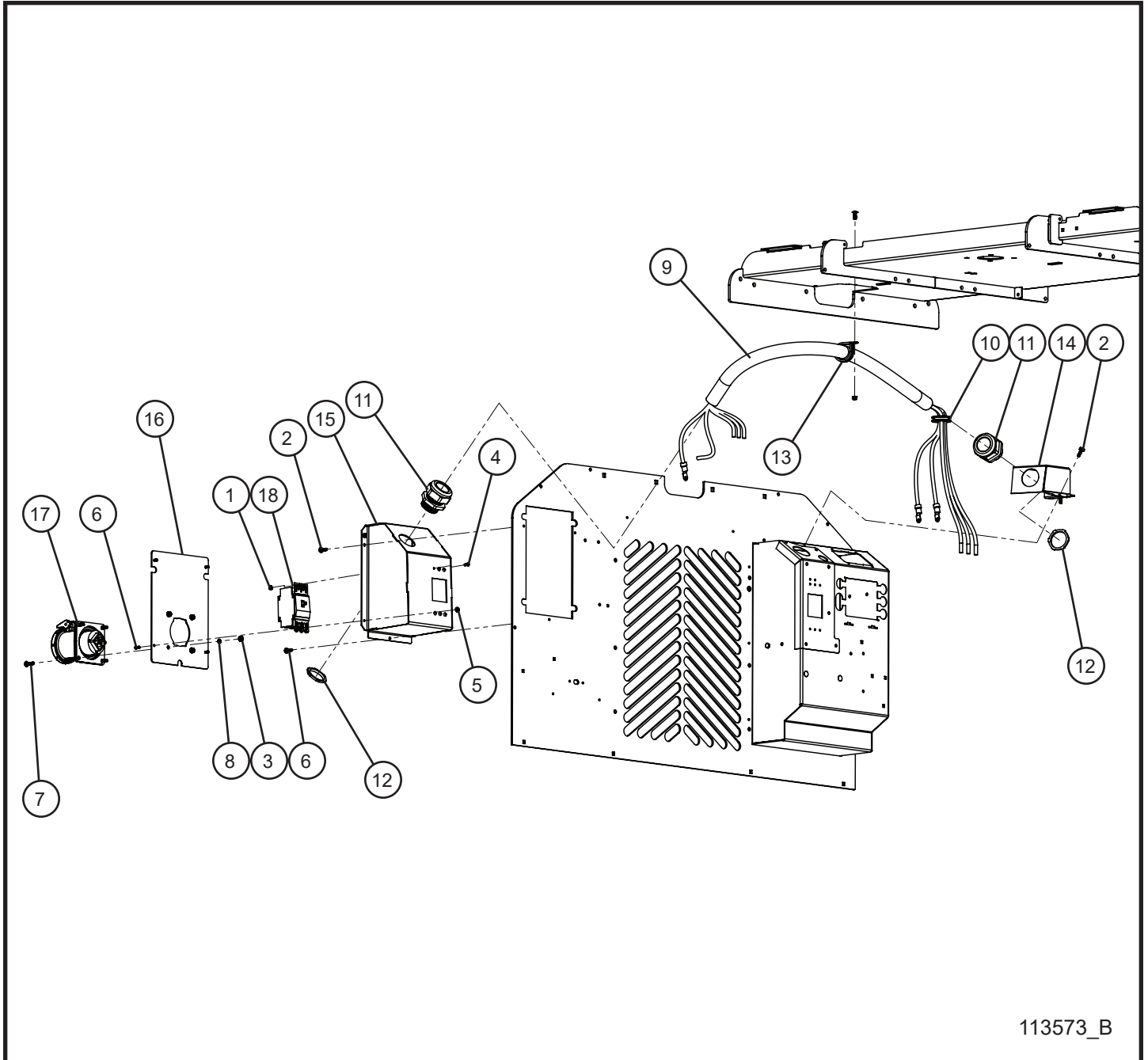

113573_B

5.3 - Auxiliary 208V 3PH Outlet Box

Item	Part No.	Part Description	Qty.
1	057003	#8-32 SERRATED FLANGE HEX LOCKNUT	6
2	041070	1/4-20 x 3/4 SL-HEX WASHER HEAD MACHINE SCREW	5
3	044021	1/4-20 KEPS HEX NUT	4
4	056006	#8-32 X 1/2 SERRATED FLANGE HEX SCREW	6
5	044016	#10-24 KEPS HEX NUT	4
6	041021	#10-24 x 1/2 PH-ROUND HEAD MACHINE SCREW	4
7	041080	1/4-20 x 1 PH-TRUSS HEAD MACHINE SCREW	4
8	043050	1/4 TOOTHLOCK WASHER	1
9	115189	208V 3PH 4/5 MAXI-LITE REAR OUTLET CORD	1
10	650542	1 1/4 ID x 1 1/2 OD GROMMET	1
11	105629	1 1/2" CORD GRIP	2
12	022232	1 1/2" CORD GRIP NUT	2
13	920365	#28 CUSHION CLAMP	1
14	113820P	MAXI-LITE AUXILIARY BREAKER BOX	1
15	113286P	AUXILIARY OUTLET BOX	1
16	113287P	AUXILIARY OUTLET COVER	1
17	680870	600V 4 PIN WATER TIGHT RECEPTACLE	1
18	022236	50A 3 POLE BREAKER	1
NS	115261	MAXI-LITE 3PH AUXILIARY OUTLET SCHEMATIC	1

5.4 - Power Lug Box Install Group (1 of 2)

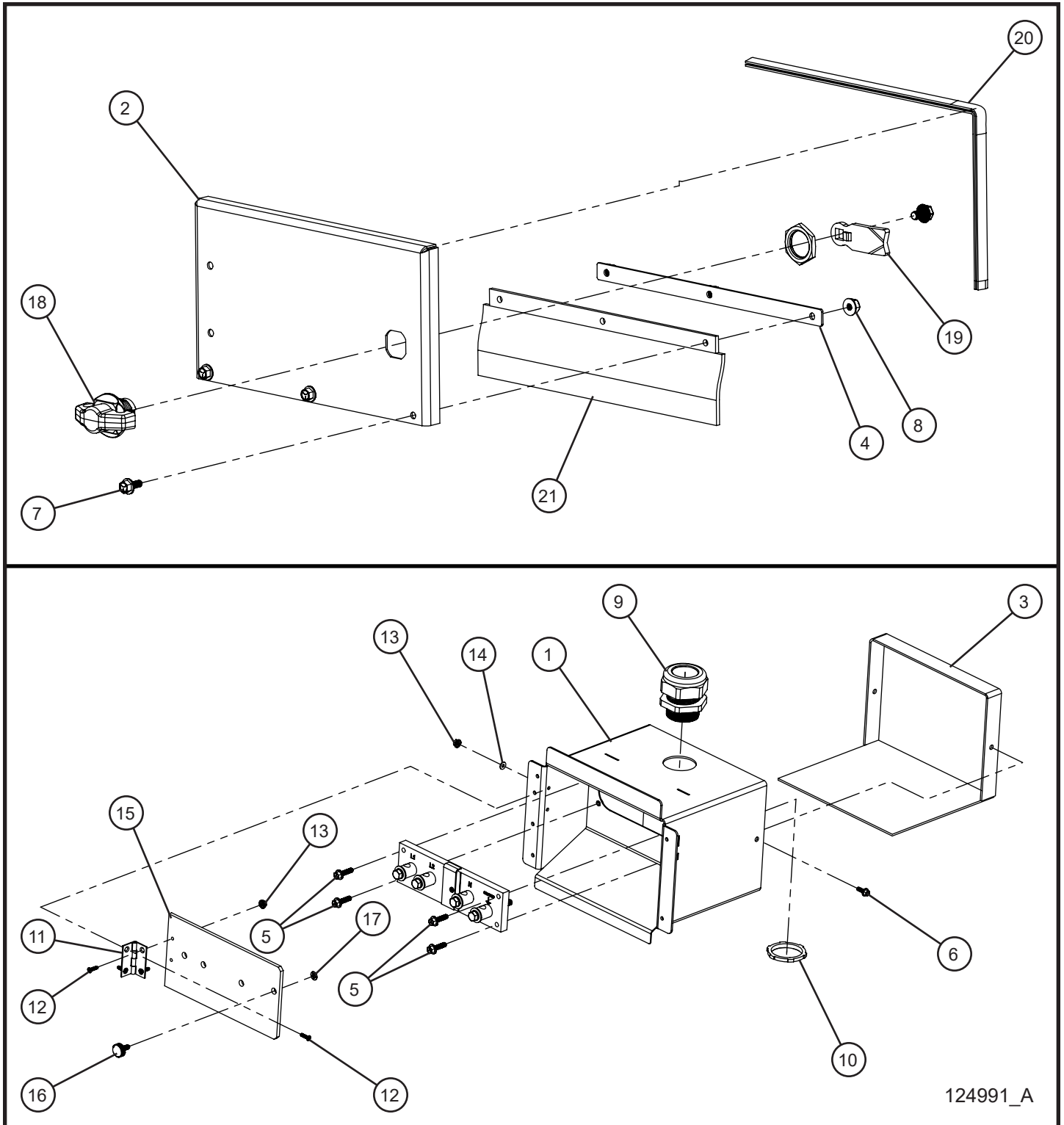

124991_A

5.4 - Power Lug Box Install Group (1 of 2)

Item	Part No.	Part Description	Qty.
1	124965P	POWER LUG BOX WELDMENT MAXI-LITE MP15XR	1
2	124969P	DOOR WELDMENT POWER LUG BOX MAXI-LITE MP15XR	1
3	124993P	REAR COVER WELDMENT MAXI-LITE MP15XR	1
4	124973P	DOOR FLAP STRAP POWER LUG BOX MAXI-LITE MP15XR	1
5	056017	1/4-20 x 1 SERRATED FLANGE HEX BOLT	4
6	056018	1/4-20 x 5/8 HEX SCREW SERRATED FLANGE	2
7	056022	#10-24 X 1/2 SERRATED FLANGE HEX SCREW	3
8	057010	#10-24 HEX NYLOCK FLANGE NUT	3
9	105629	1 1/2 CORD GRIP	2
10	022232	1 1/2 LOCK NUT	2
11	122008	STANDARD HINGE #8 HOLE 2.00 x 1.75	1
12	121414	#8-32 x 5/8 PH-FLAT HEAD COUNTERSUNK MS	4
13	057003	#8-32 SERRATED FLANGE HEX LOCKNUT	4
14	047004	#8 FLAT WASHER	2
15	125155	CLEAR COVER POWER LUG BOX MAXI-LITE MP15XR	1
16	121271	1/4-20 x 5/8 PLASTIC-HEAD THUMB SCREW	1
17	101701	1/4 PUSH NUT	1
18	111481	WINGKNOB PADLOCKABLE BLACK	1
19	111482	LATCH CAM STRAIGHT	1
20	030053	TRIMLOCK END BEAD X 14.375	1
21	125156	DOOR FLAP POWER LUG BOX MAXI-LITE MP15XR	1
NS	115259	.125 X .50 POLYURETHANE FOAM X 5.00	1
NS	104779	DISTRIBUTION BLOCK ERIFLEX	2
NS	114481	WIRE 4 AWG BLACK X 7.00	1
NS	114482	WIRE 4 AWG RED X 7.00	1
NS	115261	SCHEMATIC DIST BLOCK TO POWER LUG MAXI-LITE MP15XR	1

5.4 - Power Lug Box Install Group (2 of 2)

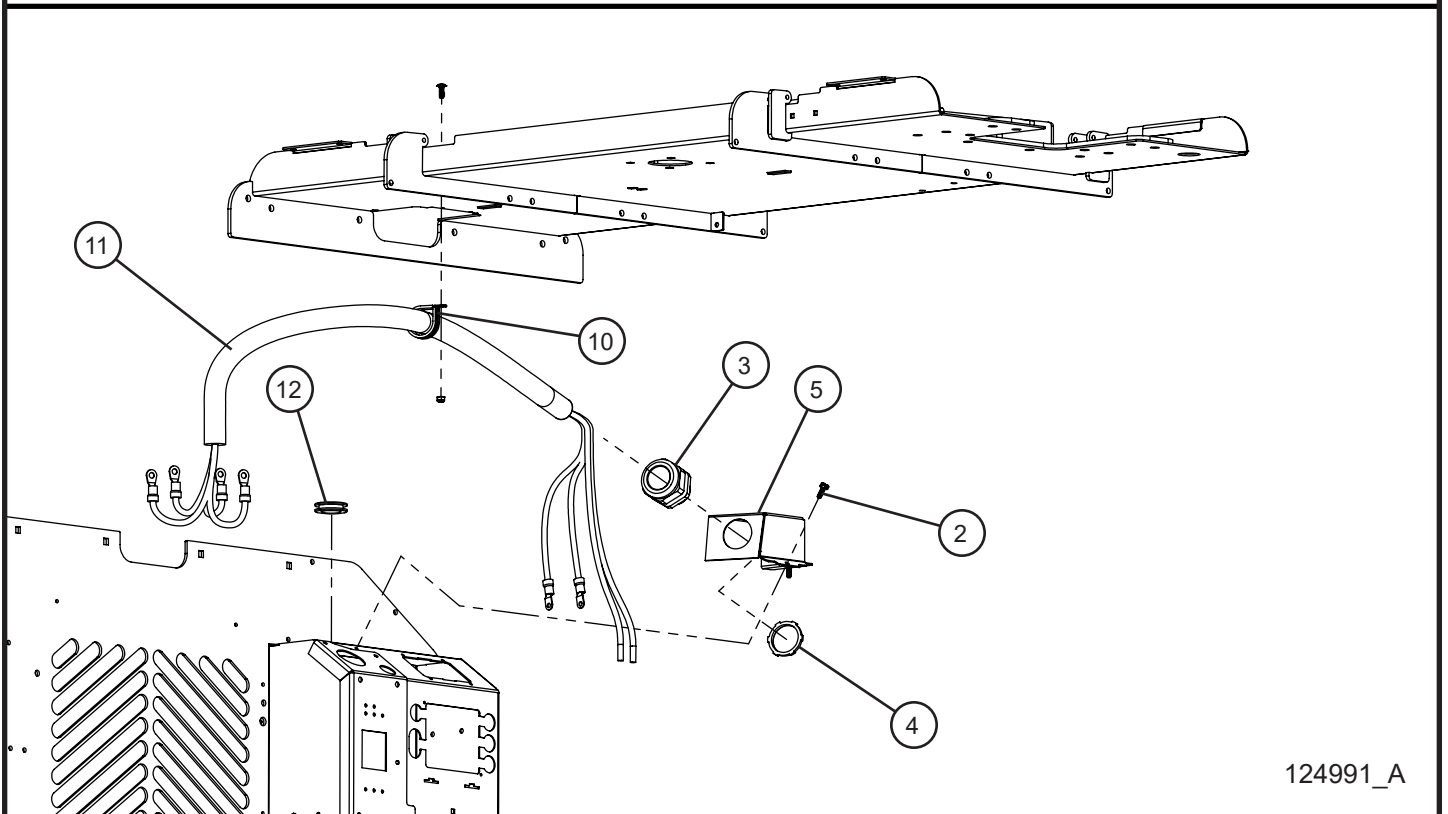
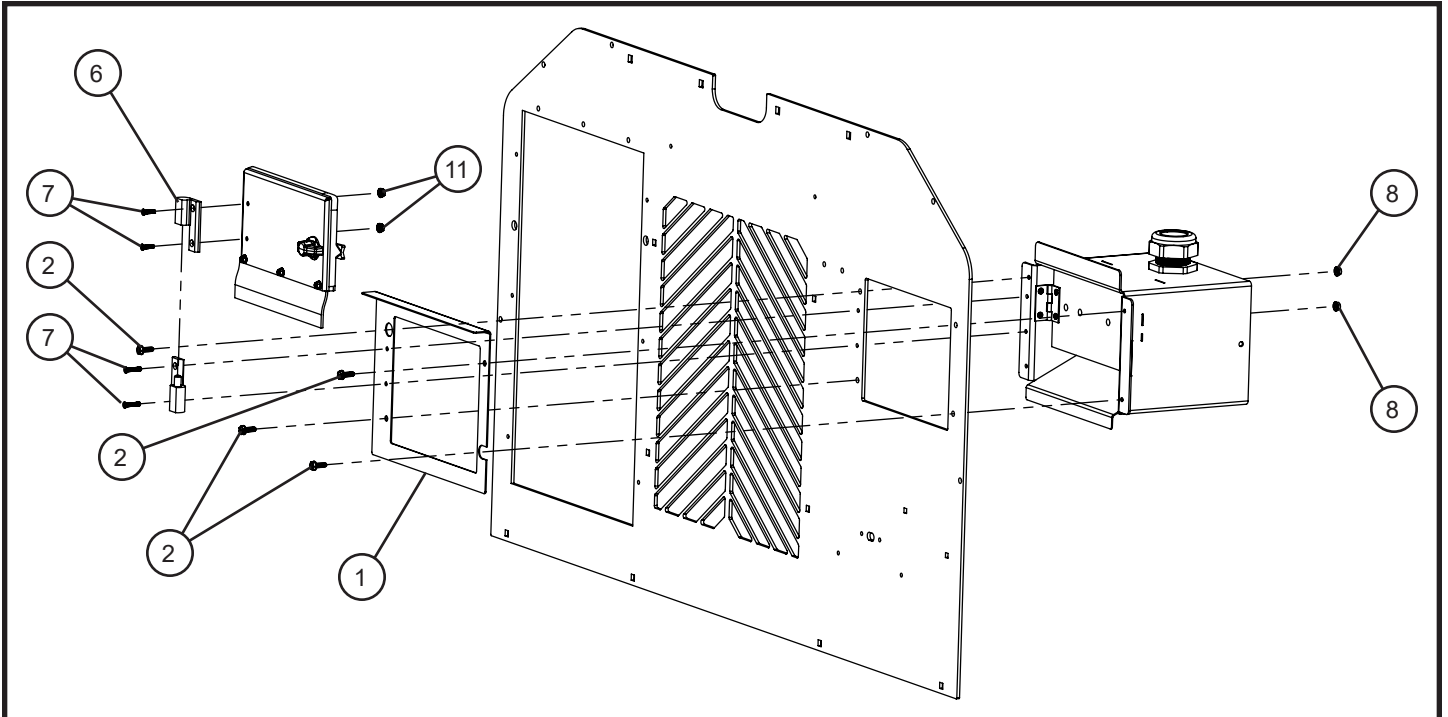

124991_A

5.4 - Power Lug Box Install Group (2 of 2)

Item	Part No.	Part Description	Qty.
1	124972P	DOOR MOUNT POWER LUG BOX MAXI-LITE MP15XR	1
2	041070	1/4-20 x 3/4 SL-HEX WASHER HEAD	6
3	105629	1 1/2 CORD GRIP	2
4	022232	1 1/2 LOCK NUT	2
5	113820P	BOX AUX BREAKER MAXI II	1
6	125493	HINGE LIFT OFF LEFT HAND METAL	1
7	041032	#10-24 X 3/4 PHILLIPS-FLAT HEAD MS	2
8	057004	#10-24 SERRATED FLANGE HEX NUT	4
9	125165	#10-24 X 1 PHILLIPS-FLAT HEAD MS	2
10	920365	#28 CUSHION CLAMP	1
11	125158	4/4 POWER CORD POWER LUG BOX MAXI-LITE MP15XR	1
12	650542	1 1/4 ID X 1 1/2 OD GROMMET	1
NS	104779	DISTRIBUTION BLOCK ERIFLEX	2
NS	114481	WIRE 4 AWG BLACK X 7.00	1
NS	114482	WIRE 4 AWG RED X 7.00	1
NS	115261	SCHEMATIC DIST BLOCK TO POWER LUG MAXI-LITE MP15XR	1

5.5 - Power Lug Plate Assembly Group

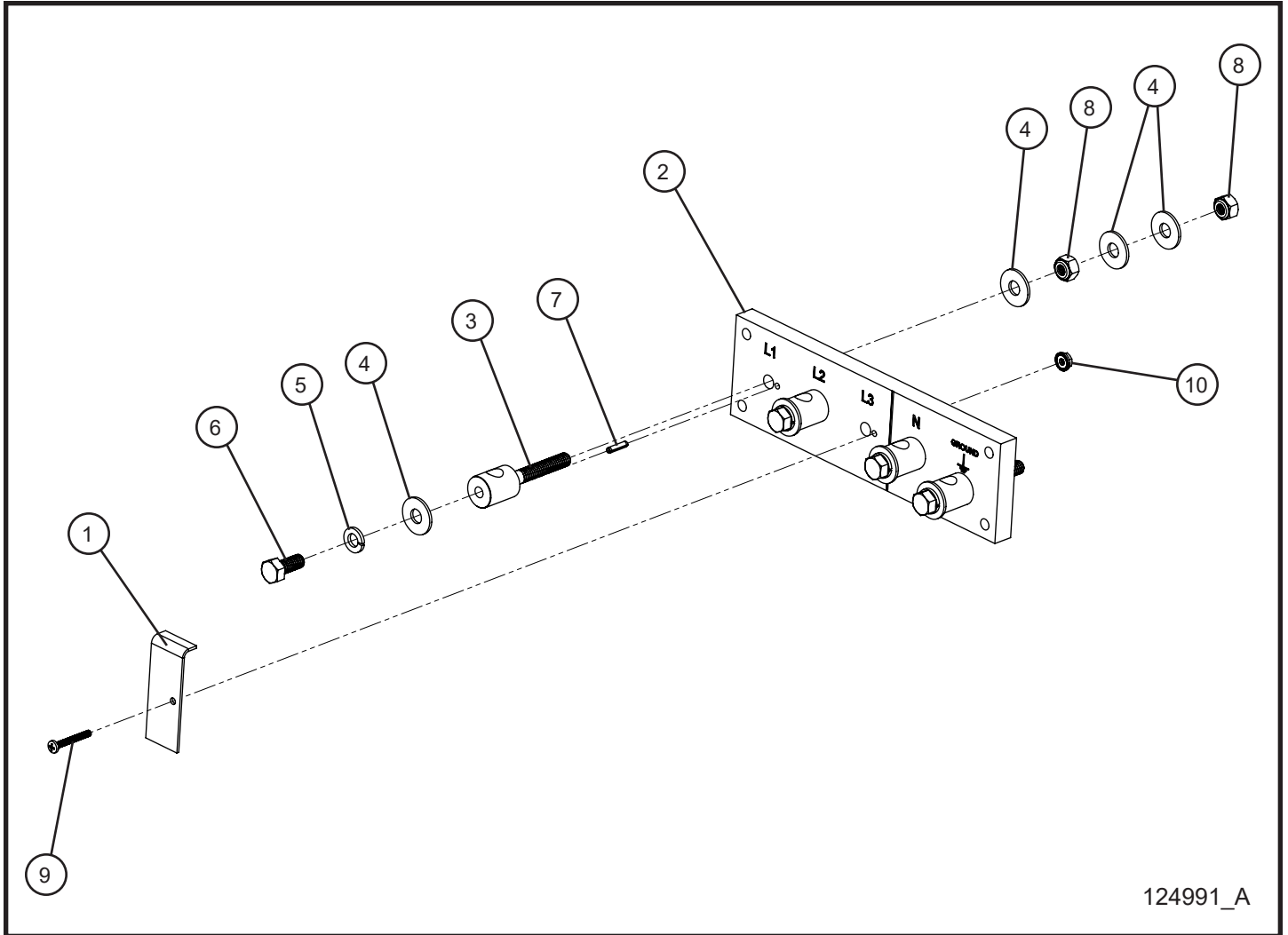

124991_A

5.5 - Power Lug Plate Assembly Group

Item	Part No.	Part Description	Qty.
1	126087P	COVER BASE LUG PLATE MAXI-LITE MP15XR 1PH	1
2	118790	ECC CONNECTION BASE LUG INSULATOR PLATE MP25	1
3	118872	MP25 ECC CONNECTION BASE CABLE LUG	4
4	047010	5/16 FLAT WASHER	16
5	043055	5/16 SPLITLOCK WASHER	4
6	046045	5/16-18 x 3/4 HEX HEAD	4
7	118874	1/8 x 9/16 SPRING ROLL PIN	4
8	044033	5/16-18 NYLOCK HEX NUT	8
9	041003	#6-32 X 1 1/4 SL-ROUND HEAD MS	1
10	057005	#6-32 SERRATED FLANGE HEX NUT	1
NS	115261	SCHEMATIC DIST BLOCK TO POWER LUG MAXI-LITE MP15XR	1

5.6 - 4-Light Switches with 725 Relays

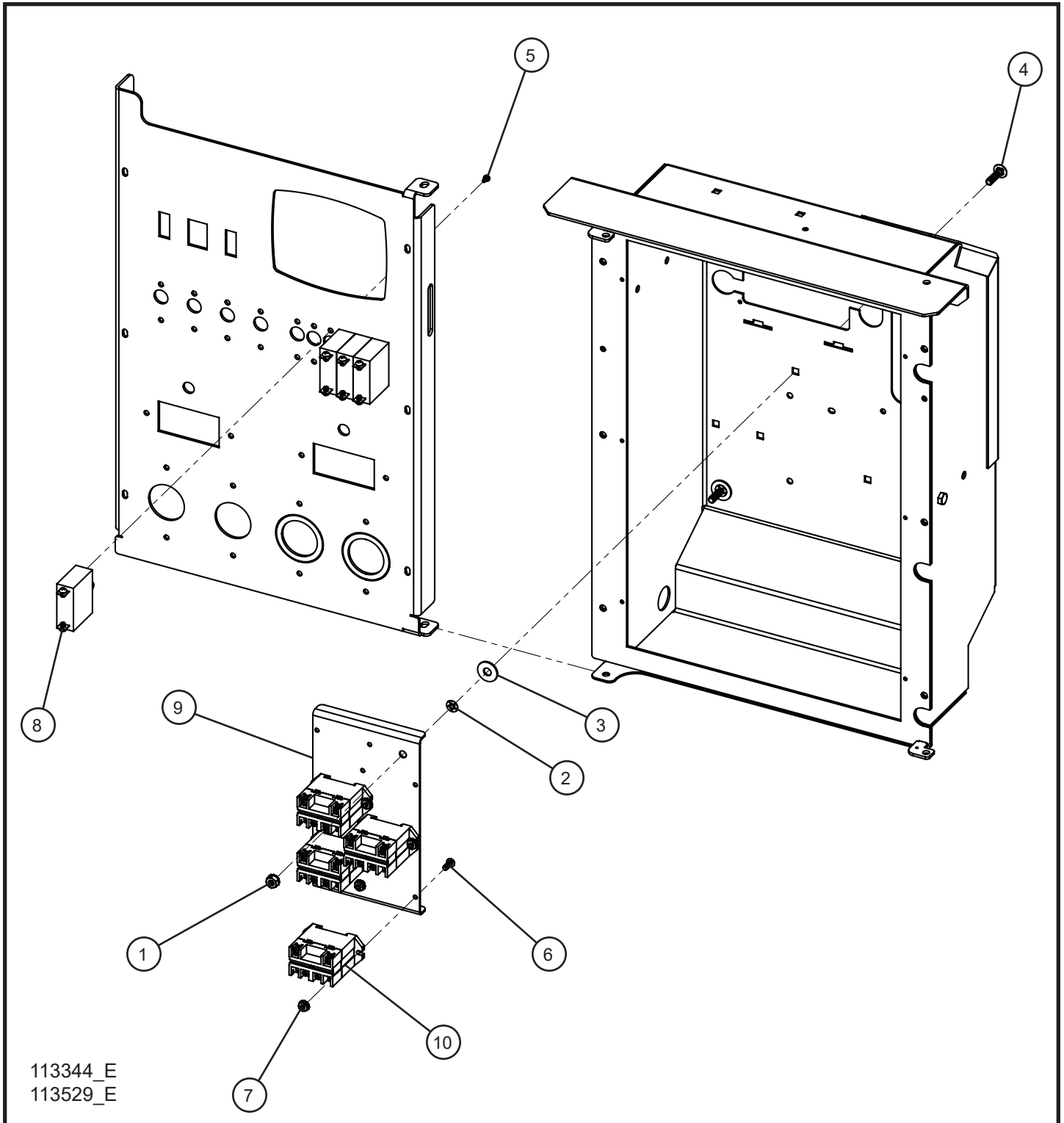

113344_E
113529_E

5.6 - 4-Light Switches with 725 Relays

Item	Part No.	Part Description	Qty.
1	044021	1/4-20 KEPS HEX NUT	2
2	101701	1/4 PUSH NUT	2
3	047010	5/16 FLAT WASHER	2
4	100342	1/4-20 x 1 CARRIAGE BOLT	2
5	041018	#6-32 x 1/4 PH-ROUND HEAD MACHINE SCREW	8
6	041012	#8-32 x 1/2 MACHINE SCREW	8
7	044003	#8-32 KEPS HEX NUT	8
8	330458	15A SPST BREAKER SWITCH	4
9	114487P	MAXI-LITE 725 RELAY BRACKET	1
10	109025	RELAY 277VAC 30AMP 12VDC COIL SPST	4
NS	115109	4 LIGHT 1PH DISTRIBUTION BLOCK LIGHT SWITCH HARNESS	1
NS	115157	4 LIGHT 3PH DISTRIBUTION BLOCK LIGHT SWITCH HARNESS	1
NS	113346	725 RELAYS 4 LIGHT AC HARNESS	1
NS	112698	725 RELAYS 4 LIGHT DC HARNESS	1
NS	114021	MAXI-LITE 4 LIGHT - 4 RELAY 1P WIRE SCHEMATIC	1
NS	114023	MAXI-LITE 4 LIGHT - 4 RELAY 3P WIRE SCHEMATIC	1

5.7 - 6-Light Switches with 725 Relays

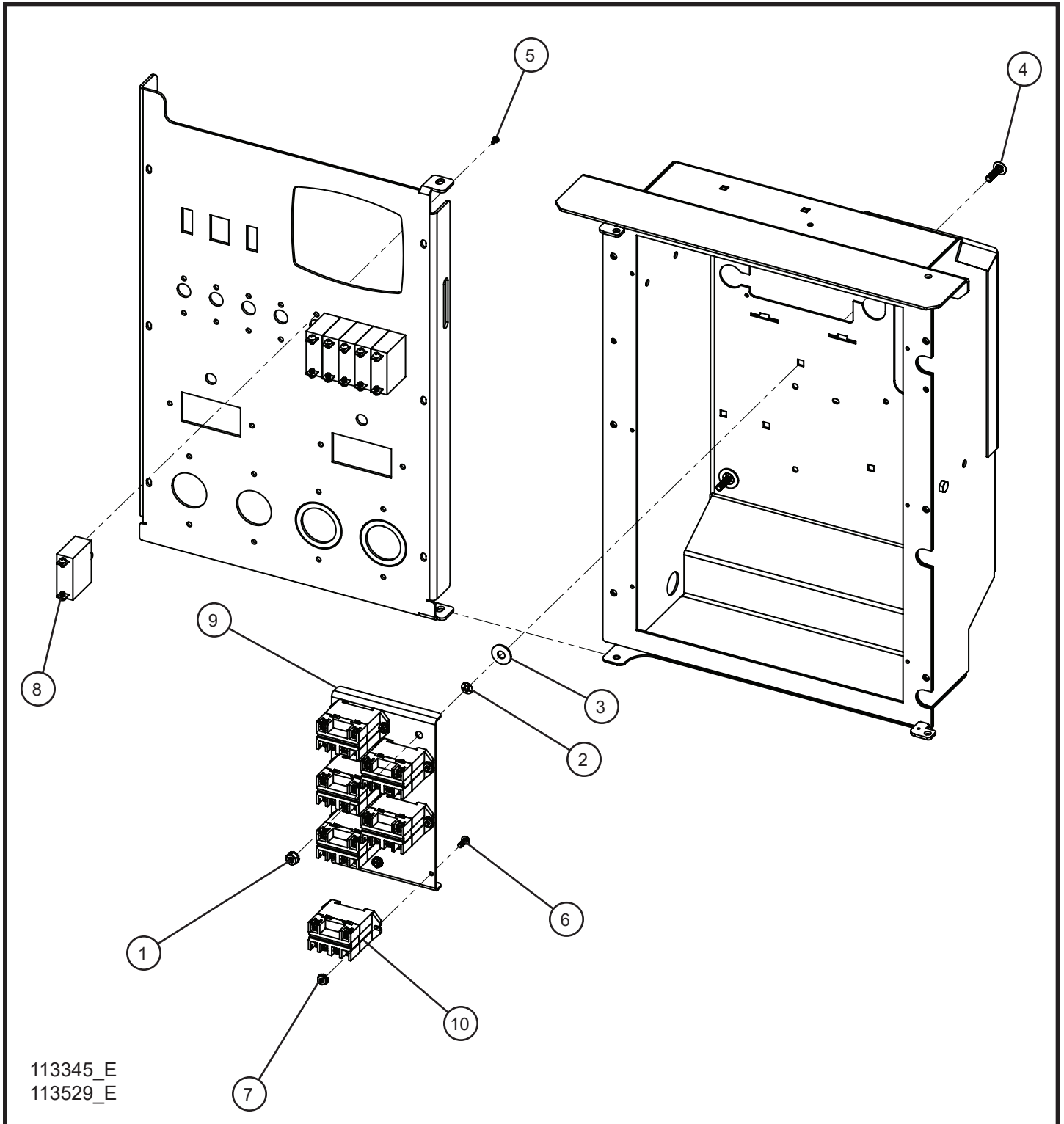

113345_E
113529_E

5.7 - 6-Light Switches with 725 Relays

Item	Part No.	Part Description	Qty.
1	044021	1/4-20 KEPS HEX NUT	2
2	101701	1/4 PUSH NUT	2
3	047010	5/16 FLAT WASHER	2
4	100342	1/4-20 x 1 CARRIAGE BOLT	2
5	041018	#6-32 x 1/4 PH-ROUND HEAD MACHINE SCREW	12
6	041012	#8-32 x 1/2 MACHINE SCREW	12
7	044003	#8-32 KEPS HEX NUT	12
8	330458	15A SPST BREAKER SWITCH	6
9	114487P	MAXI-LITE 725 RELAY BRACKET	1
10	109025	RELAY 277VAC 30AMP 12VDC COIL SPST	6
NS	113524	6 LIGHT 1PH DISTRIBUTION BLOCK LIGHT SWITCH HARNESS	1
NS	114877	6 LIGHT 3PH DISTRIBUTION BLOCK LIGHT SWITCH HARNESS	1
NS	114878	725 RELAYS 6 LIGHT AC HARNESS	1
NS	112630	725 RELAYS 6 LIGHT DC HARNESS	1
NS	114022	MAXI-LITE 6 LIGHT - 6 RELAY 1P WIRE SCHEMATIC	1
NS	114024	MAXI-LITE 6 LIGHT - 6 RELAY 3P WIRE SCHEMATIC	1

5.8 - 4-Light Switches with Zettler Relays

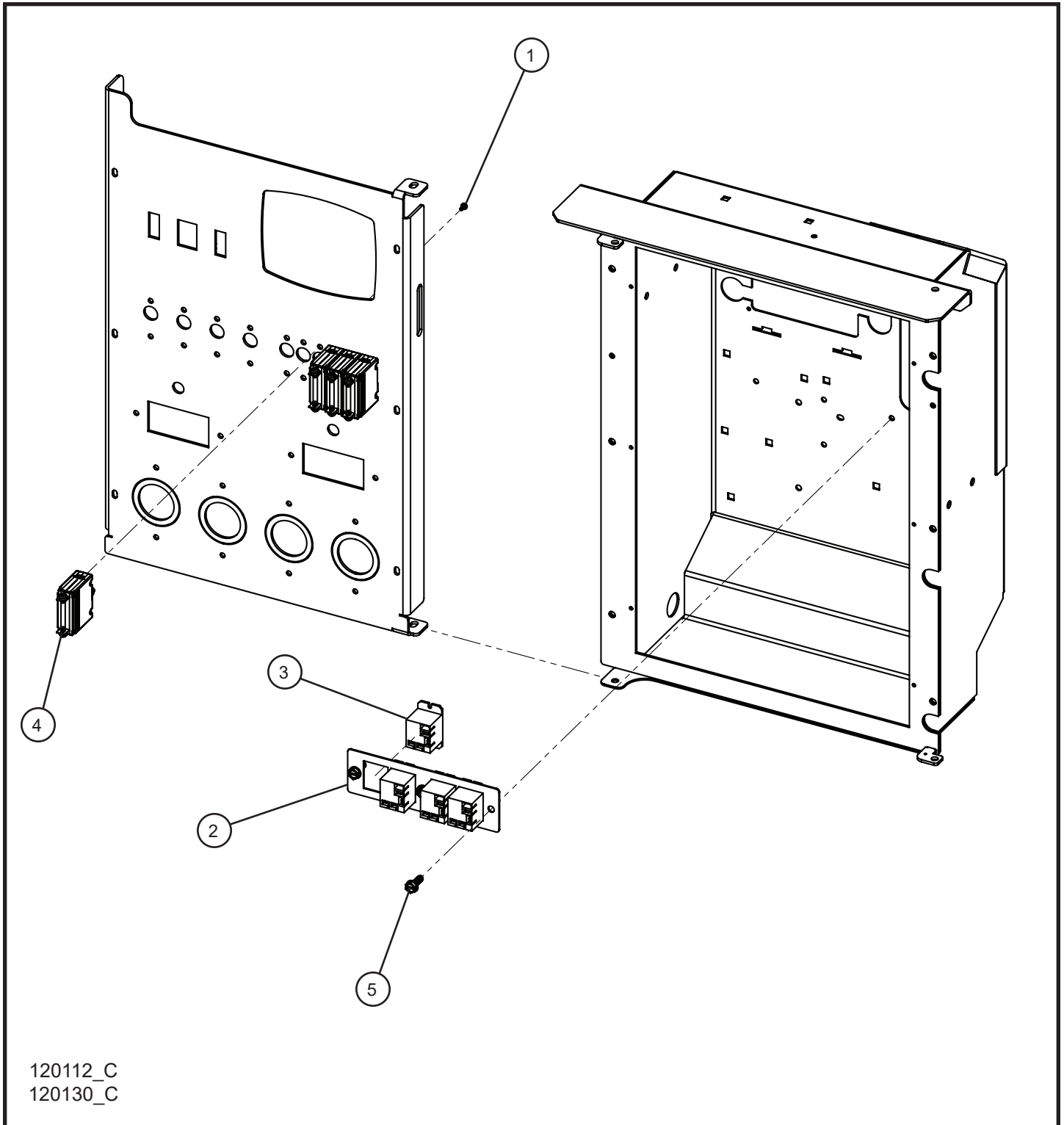

5.8 - 4-Light Switches with Zettler Relays

Item	Part No.	Part Description	Qty.
1	041018	#6-32 x 1/4 PH-ROUND HEAD MACHINE SCREW	8
2	114846P	BREAKER BOX RELAY BRACKET	1
3	104957	RELAY 120 VAC 30 AMP 12-28 VDC CONTROL	4
4	116992	5A SPST BREAKER SWITCH	4
5	041070	1/4-20 x 3/4 SL-HEX WASHER HEAD MACHINE SCREW	3
NS	115109	4 LIGHT 1PH DISTRIBUTION BLOCK LIGHT SWITCH HARNESS	1
NS	115157	4 LIGHT 3PH DISTRIBUTION BLOCK LIGHT SWITCH HARNESS	1
NS	120092	MAXI-LITE 4 LIGHT RELAY CONTROL HARNESS	1
NS	114826	LIGHT RELAY DC CONTROL HARNESS	1
NS	120510	MAXI-LITE 4 SMD LED - 4 RELAY 1P WIRE SCHEMATIC	1
NS	120512	MAXI-LITE 4 SMD LED - 4 RELAY 3P WIRE SCHEMATIC	1

5.9 - 6-Light Switches with Zettler Relays

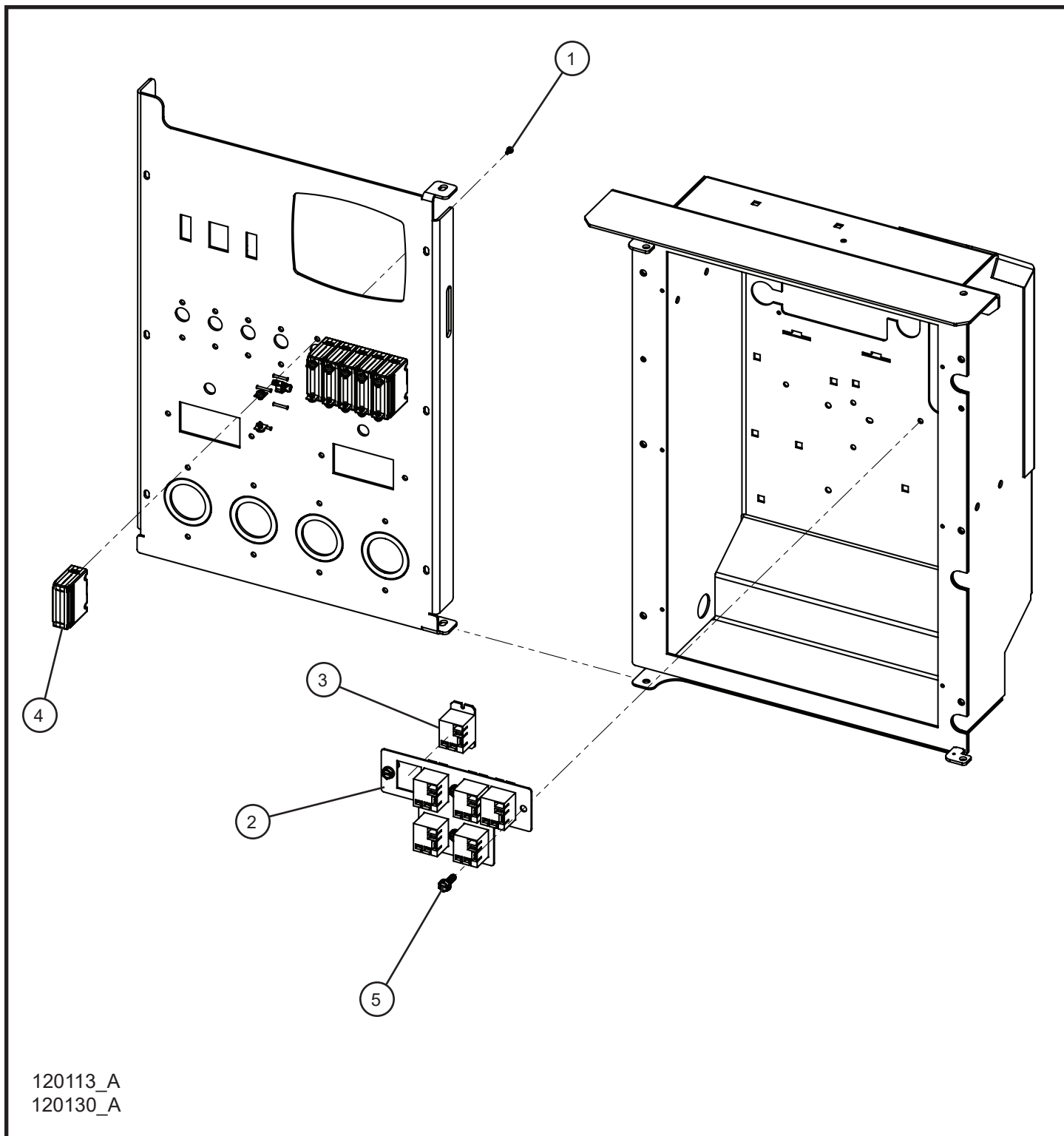

5.9 - 6-Light Switches with Zettler Relays

Item	Part No.	Part Description	Qty.
1	041018	#6-32 x 1/4 PH-ROUND HEAD MACHINE SCREW	12
2	120118P	BREAKER BOX 6 LIGHT RELAY BRACKET	1
3	104957	RELAY 120 VAC 30 AMP 12-28 VDC CONTROL	6
4	116992	5A SPST BREAKER SWITCH	6
5	041070	1/4-20 x 3/4 SL-HEX WASHER HEAD MACHINE SCREW	4
NS	113524	6 LIGHT 1PH DISTRIBUTION BLOCK LIGHT SWITCH HARNESS	1
NS	114877	6 LIGHT 3PH DISTRIBUTION BLOCK LIGHT SWITCH HARNESS	1
NS	120129	MAXI-LITE 6 LIGHT RELAY CONTROL HARNESS	1
NS	120125	LIGHT RELAY DC CONTROL HARNESS	1
NS	120511	MAXI-LITE 6 SMD LED - 6 RELAY 1P WIRE SCHEMATIC	1
NS	120513	MAXI-LITE 6 SMD LED - 6 RELAY 3P WIRE SCHEMATIC	1

6.1 - SLS Key Start Bussmann Fuse Box Assembly Group

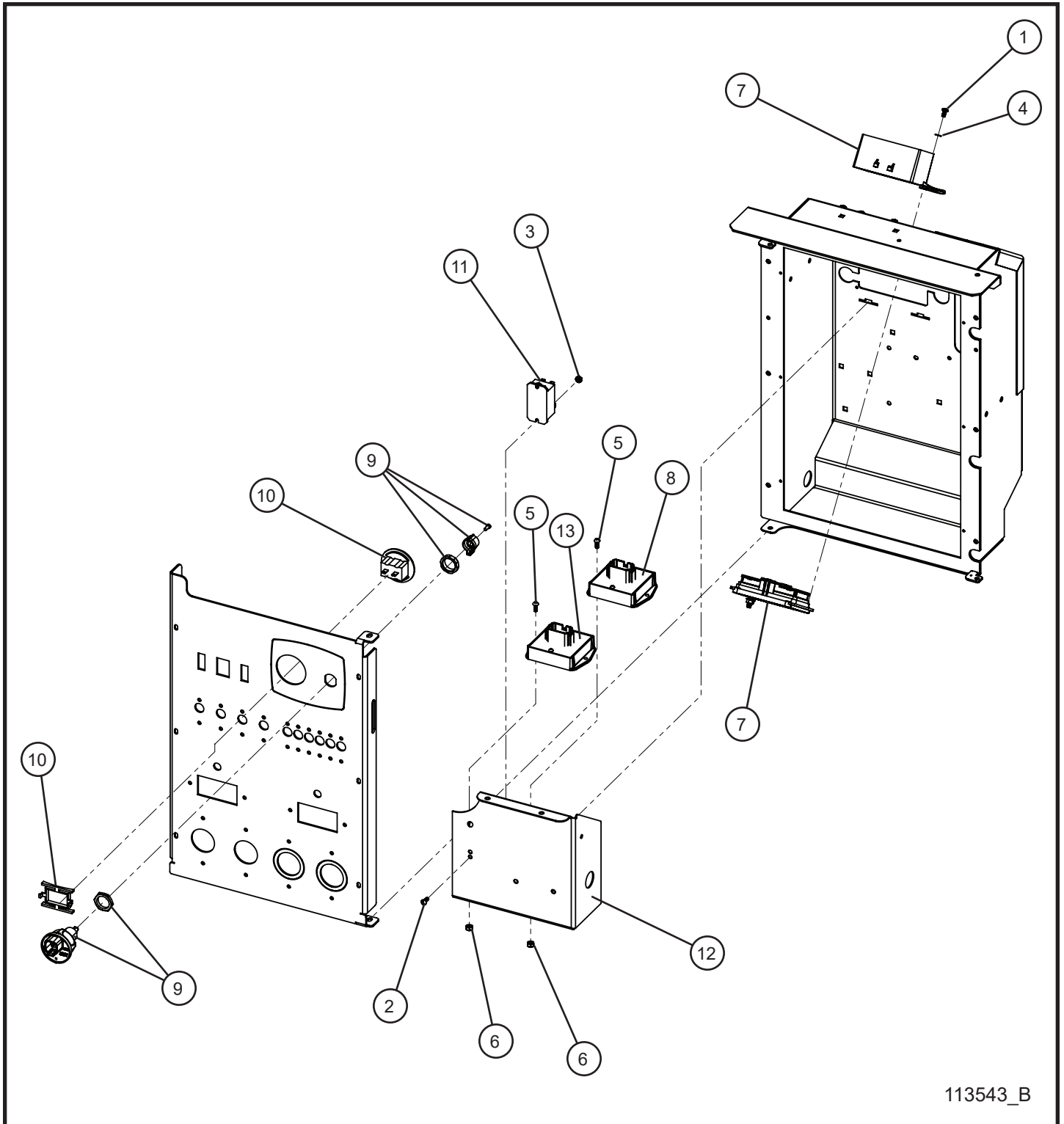

113543_B

6.1 - SLS Key Start Bussmann Fuse Box Assembly Group

Item	Part No.	Part Description	Qty.
1	041019	#10-32 x 3/8 PH-ROUND HEAD MACHINE SCREW	4
2	041013	#8-32 x 1/2 SLOTTED ROUND HEAD MACHINE SCREW	2
3	044003	#8-32 KEPS NUT	2
4	043017	#10 TOOTH LOCK WASHER	1
5	041021	#10-24 x 1/2 PH-ROUND HEAD MACHINE SCREW	4
6	044019	#10-24 NYLOCK HEX NUT	4
7	113338	SLS CONTROL PANEL HARNESS	1
8	108053	SLS 1.1 MODULE	1
9	106273	DEUTSCH CONNECT LEVER STYLE IGNITION SWITCH	1
10	340014	HOUR METER DIGITAL	1
11	105219	RELAY 30 AMP	1
12	111227P	MAXI-LITE COMPONENT BOX DIVIDER PANEL	1
13	105856	MODULE WITH 5V POWER SUPPLY	1
NS	103864	FUSE HOLDER INLINE BLADE	1
NS	104990	2 AMP ATO/ATC BLADE FUSE	1
NS	105900	LOW FUEL LEVEL MODULE HARNESS	1
NS	105901	LOW FUEL MODULE WIRE SCHEMATIC	1
NS	124717	SCHEMATIC ENGINE RUN SLS RELAY PRO & MAXI-LITE	1
NS	110123	SLS / KEY START SCHEMATIC	1

6.2 - SLS Harness Bussmann PDM Fuse Box

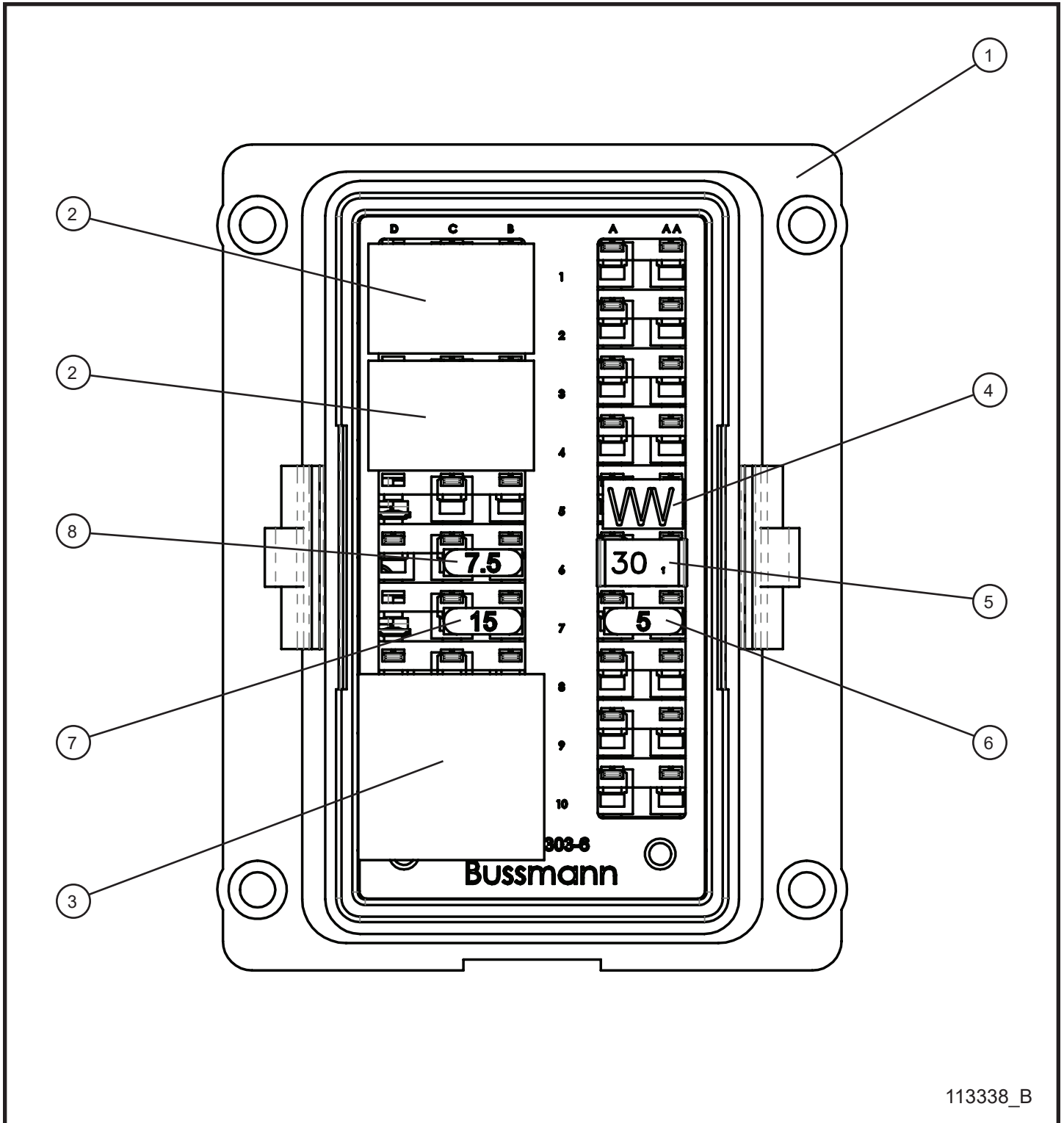

113338_B

6.2 - SLS Harness Bussmann PDM Fuse Box

Item	Part No.	Part Description	Qty.
--	113338	HARNESS SLS CONTROL PANEL COMPLETE	1
1	105199	BUSSMANN 45 PIN BOARD MODULE	1
2	105201	35 AMP SPST RELAY	2
3	105202	50 AMP SPST RELAY	1
4	105204	RESISTOR 68OHM	1
5	105832	CIRCUIT BREAKER 30A	1
6	105843	5A MINI FUSE	1
7	105844	15A MINI FUSE	1
8	105876	7.5A MINI FUSE	1

6.3 - LSC Bussmann Fuse Box Assembly Group

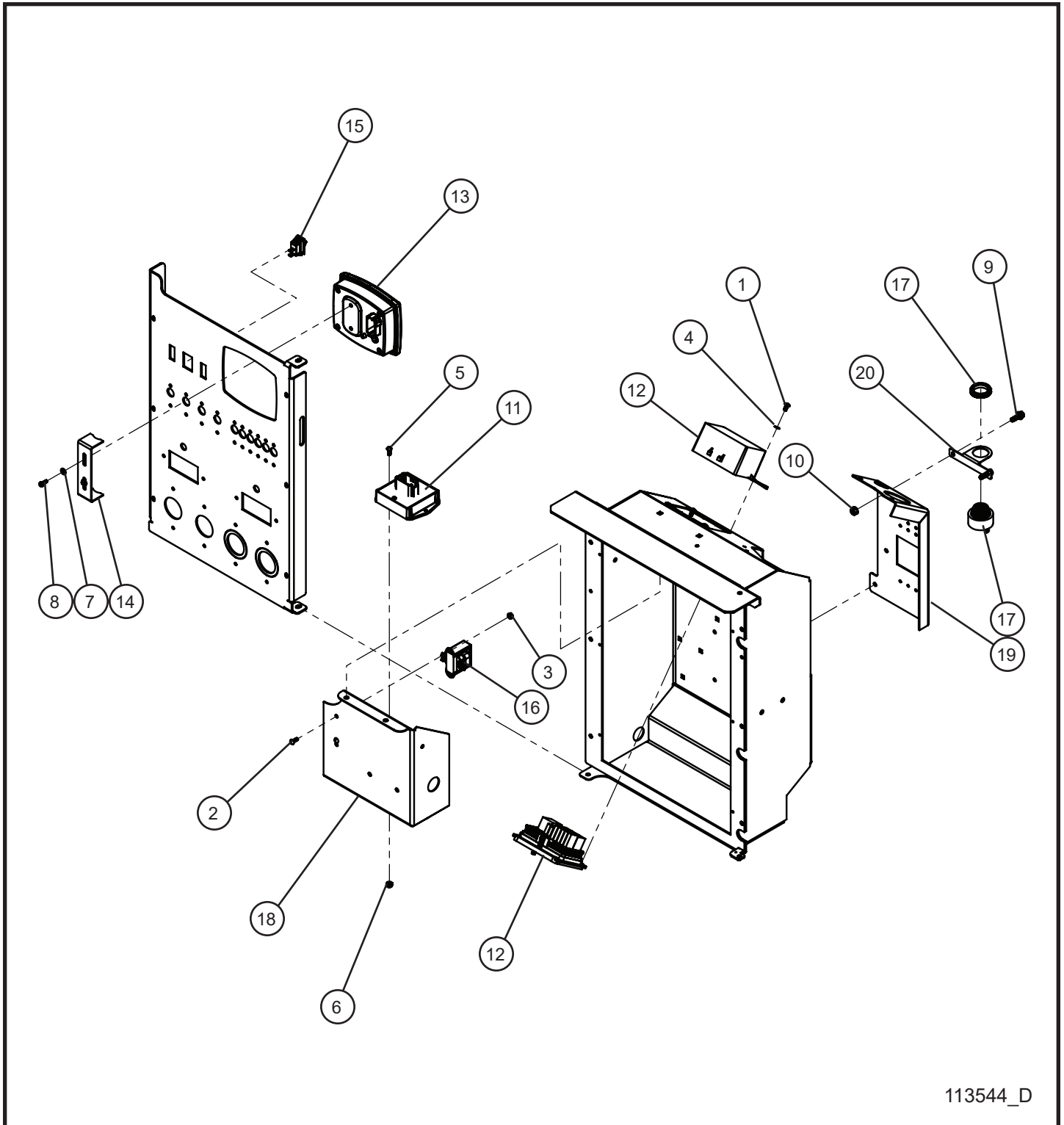

113544_D

6.3 - LSC Bussmann Fuse Box Assembly Group

Item	Part No.	Part Description	Qty.
1	041019	#10-32 x 3/8 PH-ROUND HEAD MACHINE SCREW	4
2	041013	#8-32 x 1/2 SLOTTED ROUND HEAD MACHINE SCREW	2
3	044003	#8-32 KEPS NUT	2
4	043017	#10 TOOTH LOCK WASHER	1
5	041021	#10-24 x 1/2 PH-ROUND HEAD MACHINE SCREW	2
6	044019	#10-24 NYLOCK HEX NUT	2
7	047004	#8 FLAT WASHER	2
8	041200	#8-32 x 1/2 HEX WASHER HEAD	2
9	056019	1/4-20 X 3/4 HEX FLANGE SCREW	2
10	044021	1/4-20 KEPS HEX NUT	2
11	108053	SLS 1.1 MODULE	1
12	116653	HARNESS LSC CONTROL PANEL MAX-LITE	1
13	107404	LSC 2.1 MODULE	1
14	105188P	LSC BACK BRACKET	1
15	113541	ROCKER SWITCH SPST ON / OFF	1
16	108057	POWER FILAMENT 266 SERIES TRANSFORMER	1
17	105846	AUDIBLE ALARM PANEL MOUNT	1
18	111227P	MAXI-LITE COMPONENT BOX DIVIDER PANEL	1
19	112434P	MAXI-LITE MAIN BREAKER PANEL	1
20	120575P	ALARM BRACKET OLD HOLE PATTERN COMPATIBLE	1
NS	106037	AUTOSTART ALARM WIRE HARNESS	1
NS	103864	FUSE HOLDER INLINE BLADE	1
NS	104990	2 AMP ATO/ATC BLADE FUSE	1
NS	124721	SCHEMATIC 117/6.3V TRANSFORMER LSC 2.1 MAXI-LITE	1
NS	113652	LSC WIRE HARNESS SCHEMATIC	1

6.4 - LSC Harness Bussmann PDM Fuse Box

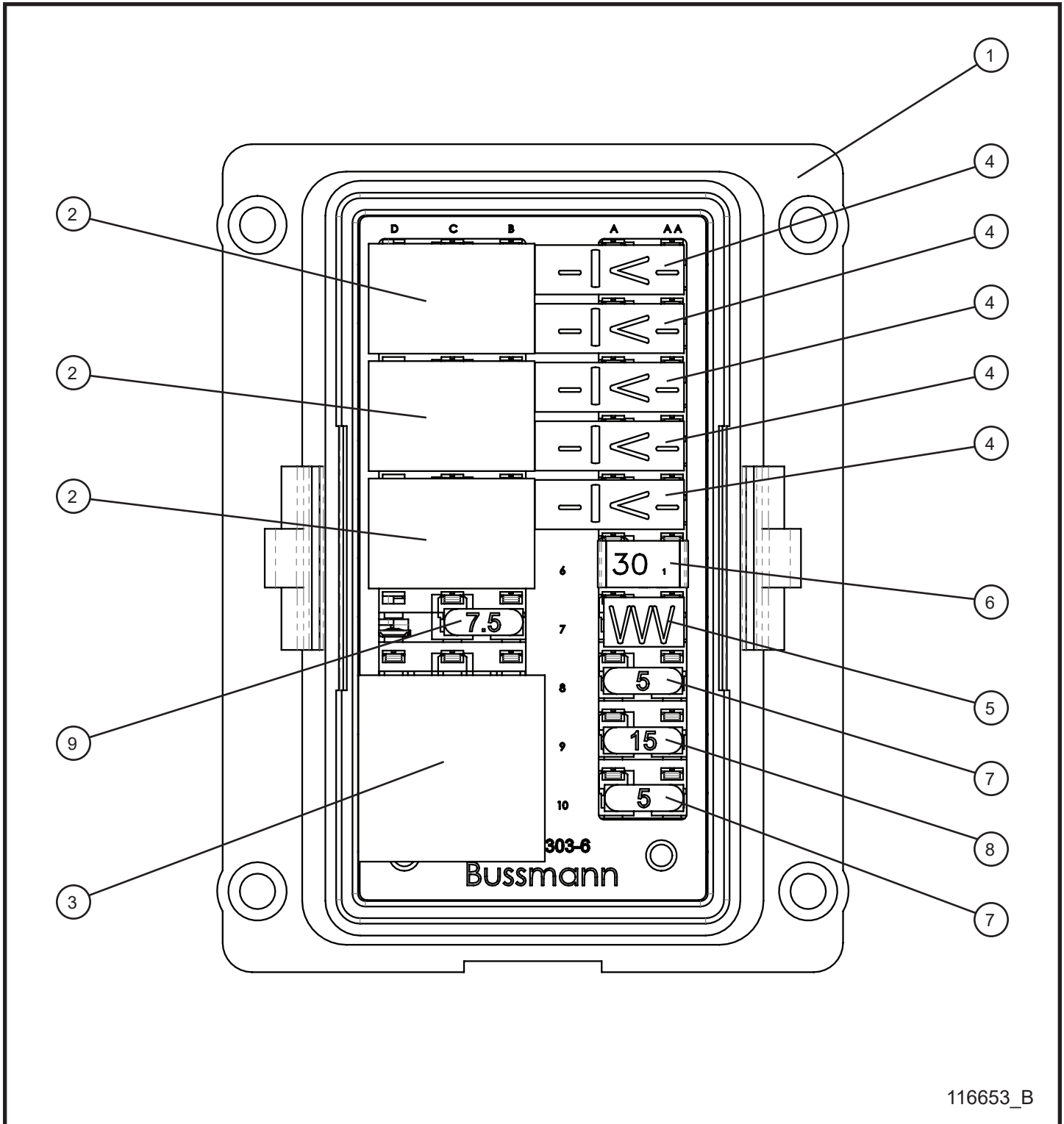

116653_B

6.4 - LSC Harness Bussmann PDM Fuse Box

Item	Part No.	Part Description	Qty.
--	116653	HARNESS LSC CONTROL PANEL MAX-LITE	1
1	105199	BUSSMANN 45 PIN BOARD MODULE	1
2	105201	35 AMP SPST RELAY	3
3	105202	50 AMP SPST RELAY	1
4	105203	BLOCKING DIODE KEYED	5
5	105204	RESISTOR 68OHM	1
6	105832	CIRCUIT BREAKER 30A	1
7	105843	5A MINI FUSE	2
8	105844	15A MINI FUSE	1
9	105876	7.5A MINI FUSE	1

6.5 - Isuzu DSE 4520 MK II Control Box Assembly Group

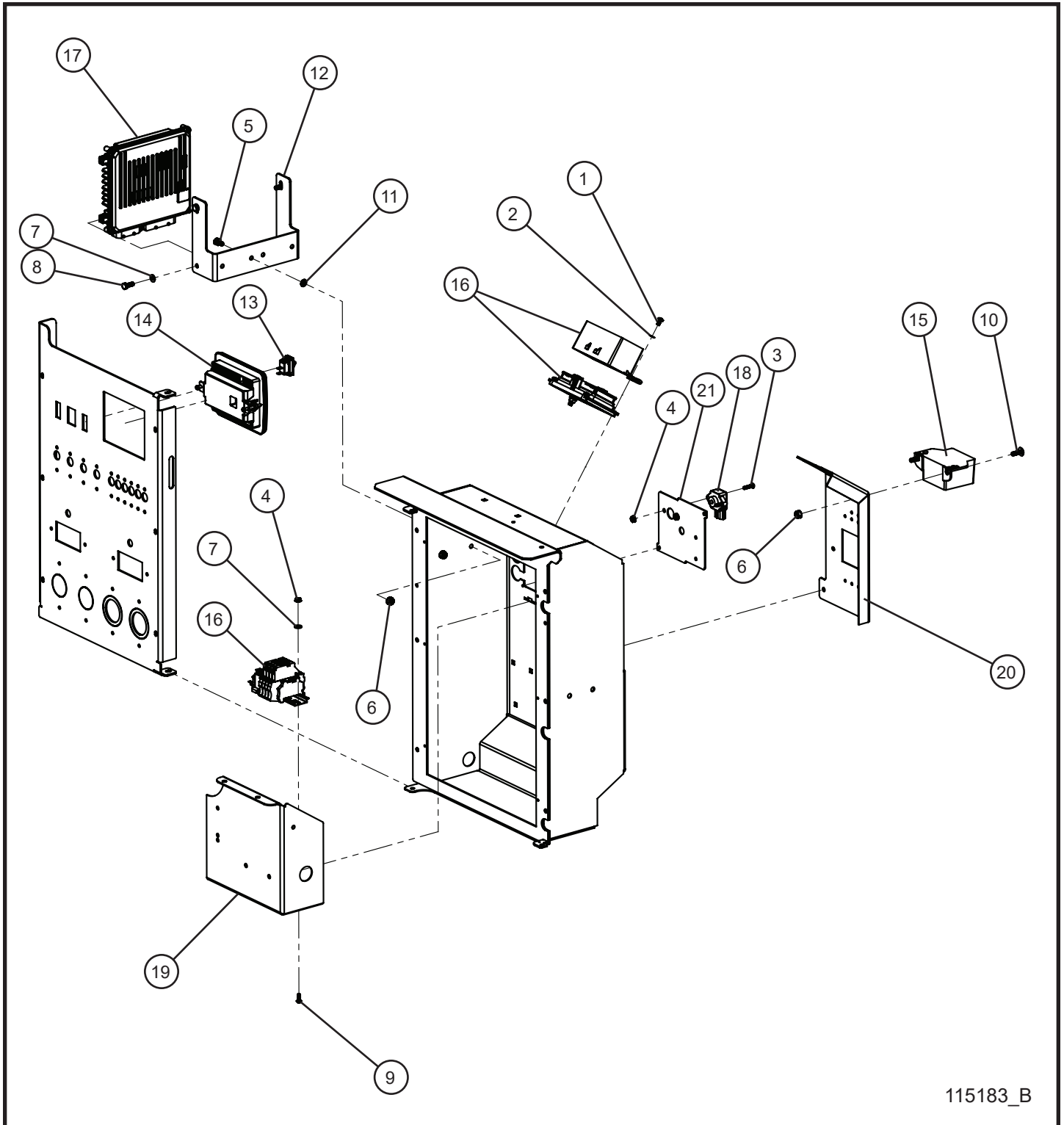

115183_B

6.5 - Isuzu DSE 4520 MK II Control Box Assembly Group

Item	Part No.	Part Description	Qty.
1	041019	#10-32 x 3/8 PH-ROUND HEAD MACHINE SCREW	4
2	043017	#10 TOOTH LOCK WASHER	1
3	041027	#10-24 x 3/4 PH-ROUND HEAD MACHINE SCREW	2
4	044016	#10-24 KEPS HEX NUT	4
5	046005	1/4-20 x 1/2 HEX HEAD BOLT	2
6	044021	1/4-20 KEPS HEX NUT	4
7	047070	#10 FLAT WASHER	6
8	042019	M6 x 1mm x 16mm HEX HEAD BOLT	4
9	041021	#10-24 x 1/2 PH-ROUND HEAD MACHINE SCREW	2
10	041050	1/4-20 x 3/4 PH-TRUSS HEAD MACHINE SCREW	2
11	101701	1/4 PUSH NUT	2
12	112555P	ISUZU 4LE2T ECM BRACKET	1
13	113541	ROCKER SWITCH SPST ON / OFF	1
14	113504	DSE 4520 MK II CONTROL MODULE	1
15	105846	ALARM 102 DB	1
16	107927	HARNESS ISUZU 4LE2T T4F DSE 4520 MK II	1
17	N/A	ENGINE CONTROL MODULE (ECM)	1
18	N/A	BAROMETRIC PRESSURE SENSOR	1
19	111227P	MAXI-LITE COMPONENT BOX DIVIDER PANEL	1
20	112434P	MAXI-LITE MAIN BREAKER PANEL	1
21	111228P	MAXI-LITE COMPONENT BOX BACK COVER	1
NS	106037	AUTOSTART ALARM WIRE HARNESS	1

6.6 - Isuzu DSE 4520 MK II Harness Fuse Box

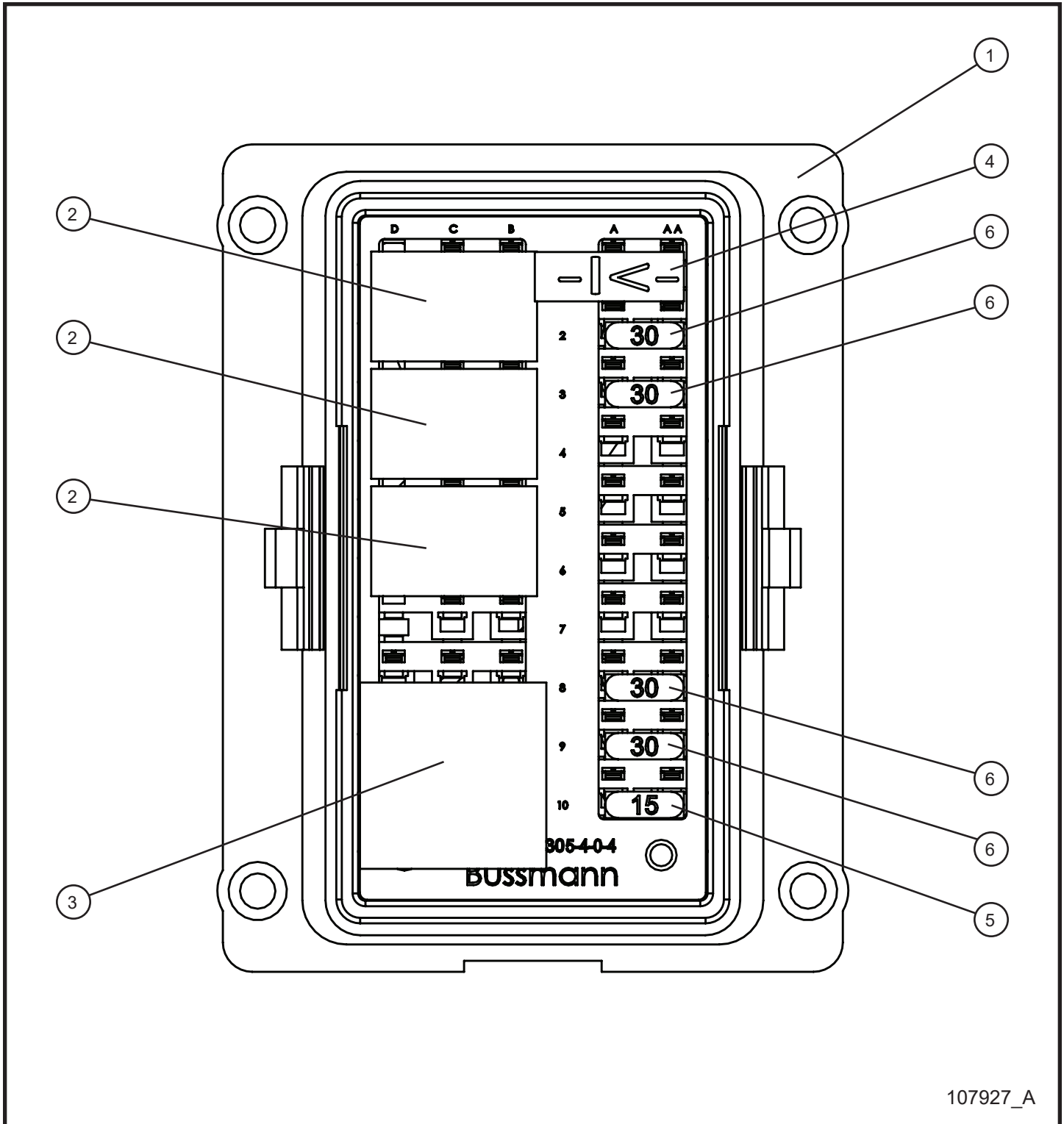

107927_A

6.6 - Isuzu DSE 4520 MK II Harness Fuse Box

Item	Part No.	Part Description	Qty.
--	107927	HARNESS ISUZU 4LE2T T4F DSE 4520 MK II	1
1	107913	BUSSMANN 50 PIN BOARD MODULE	1
2	107928	35 AMP SPST RELAY	3
3	105202	50 AMP SPST RELAY	1
4	105203	BLOCKING DIODE KEYED	1
5	105844	15A MINI FUSE	1
6	107929	30A MINI FUSE	4

6.7 - Isuzu DSE 4520 MK II Relay and Terminal Blocks

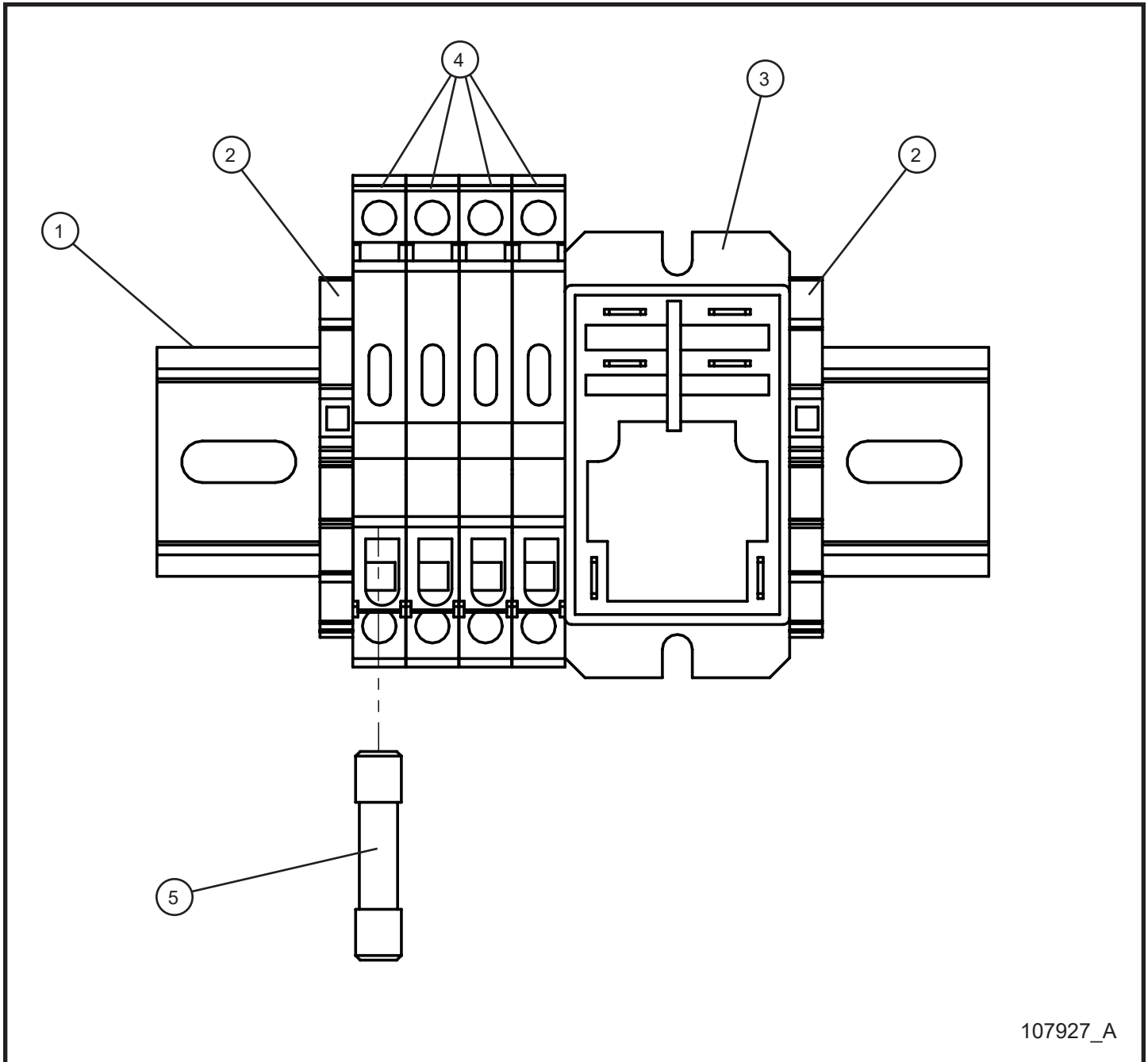

107927_A

6.7 - Isuzu DSE 4520 MK II Relay and Terminal Blocks

Item	Part No.	Part Description	Qty.
--	107927	HARNES ISUZU 4LE2T T4F DSE 4520 MK II	1
1	105775	5" 35mm DIN RAIL	1
2	107377	24-10 AWG END STOP	2
3	106864	30 AMP DC POWER RELAY	1
4	107540	24-10 AWG FUSE TERMINAL BLOCK	4
5	108459	2 AMP GMA FUSE	4

6.8 - Isuzu DSE L401 MK II Control Box Assembly Group

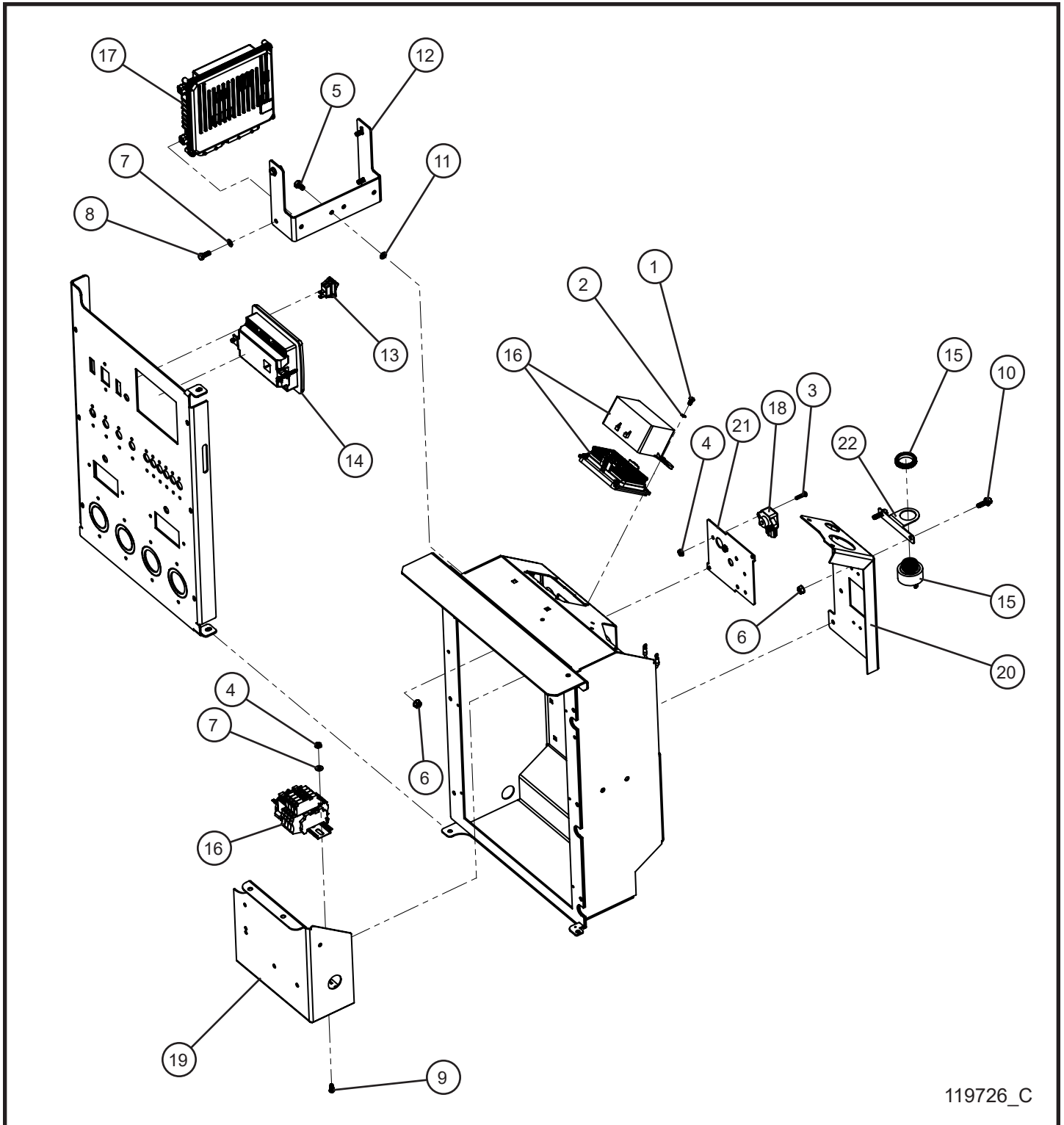

119726_C

6.8 - Isuzu DSE L401 MK II Control Box Assembly Group

Item	Part No.	Part Description	Qty.
1	041019	#10-32 x 3/8 PH-ROUND HEAD MACHINE SCREW	4
2	043017	#10 TOOTH LOCK WASHER	1
3	041027	#10-24 x 3/4 PH-ROUND HEAD MACHINE SCREW	2
4	044016	#10-24 KEPS HEX NUT	4
5	046005	1/4-20 x 1/2 HEX HEAD BOLT	2
6	044021	1/4-20 KEPS HEX NUT	4
7	047070	#10 FLAT WASHER	6
8	042019	M6 x 1mm x 16mm HEX HEAD BOLT	4
9	041021	#10-24 x 1/2 PH-ROUND HEAD MACHINE SCREW	2
10	056019	1/4-20 X 3/4 HEX FLANGE SCREW	2
11	101701	1/4 PUSH NUT	2
12	112555P	ISUZU 4LE2T ECM BRACKET	1
13	113541	ROCKER SWITCH SPST ON / OFF	1
14	110154	DSE L401 MK II CONTROL MODULE	1
15	118086	AUDIBLE ALARM PANEL MOUNT	1
16	116064	HARNESS ISUZU 4LE2T T4F DSE L401 MK II	1
17	N/A	ENGINE CONTROL MODULE (ECM)	1
18	N/A	BAROMETRIC PRESSURE SENSOR	1
19	111227P	MAXI-LITE COMPONENT BOX DIVIDER PANEL	1
20	112434P	MAXI-LITE MAIN BREAKER PANEL	1
21	111228P	MAXI-LITE COMPONENT BOX BACK COVER	1
22	120575P	ALARM BRACKET OLD HOLE PATTERN COMPATIBLE	1
NS	103864	FUSE HOLDER INLINE BLADE	1
NS	104990	FUSE BLADE 2 AMP ATO/ATC	1
NS	106037	AUTOSTART ALARM WIRE HARNESS	1

6.9 - Isuzu DSE L401 MK II Harness Fuse Box

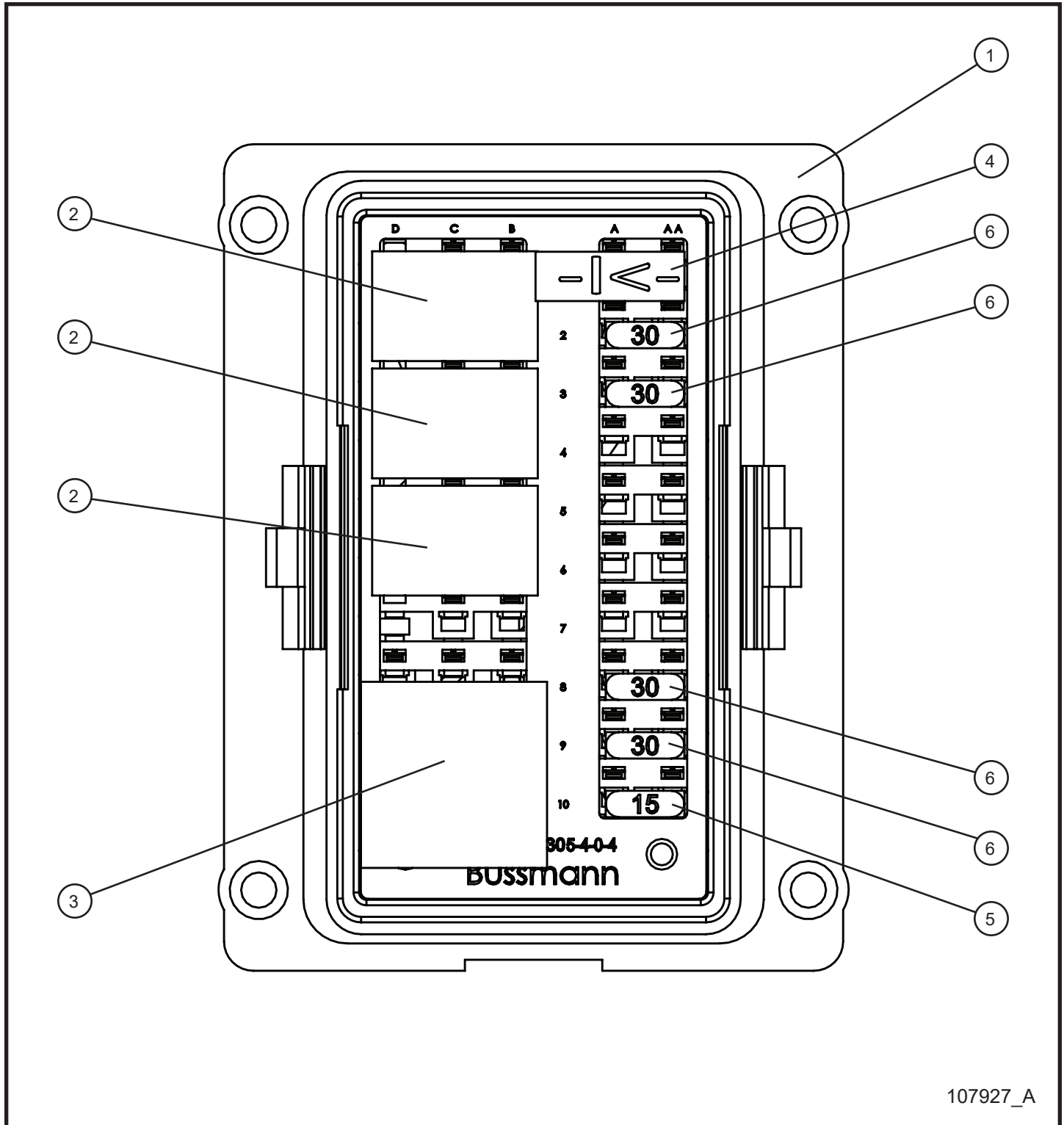

107927_A

6.9 - Isuzu DSE L401 MK II Harness Fuse Box

Item	Part No.	Part Description	Qty.
--	116064	HARNESS ISUZU 4LE2T T4F DSE L401 MK II	1
1	107913	BUSSMANN 50 PIN BOARD MODULE	1
2	107928	35 AMP SPST RELAY	3
3	105202	50 AMP SPST RELAY	1
4	105203	BLOCKING DIODE KEYED	1
5	105844	15A MINI FUSE	1
6	107929	30A MINI FUSE	4

6.10 - Isuzu DSE L401 MK II Relay and Terminal Blocks

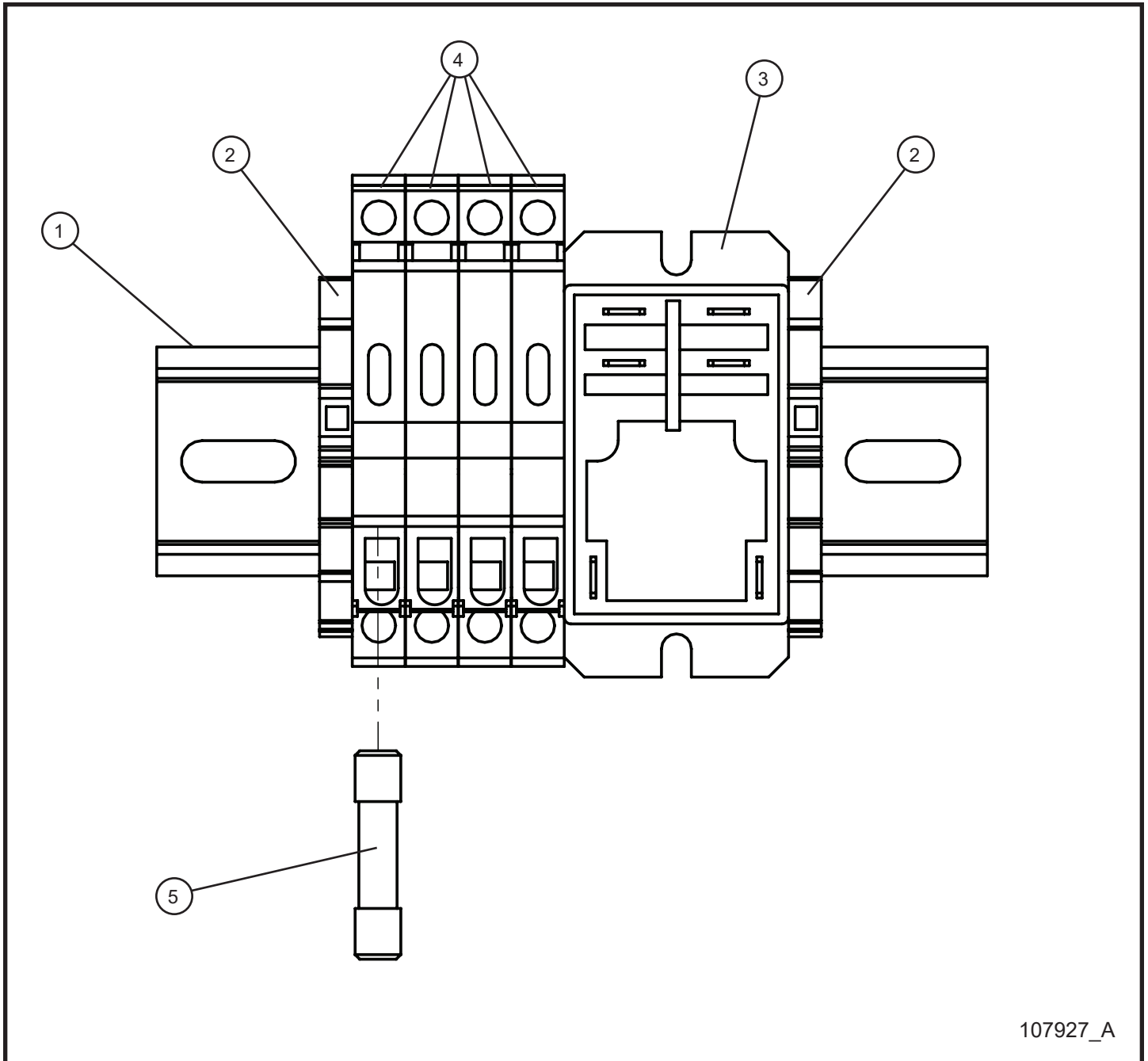

107927_A

6.10 - Isuzu DSE L401 MK II Relay and Terminal Blocks

Item	Part No.	Part Description	Qty.
--	116064	HARNESSES ISUZU 4LE2T T4F DSE L401 MK II	1
1	105775	5" 35mm DIN RAIL	1
2	107377	24-10 AWG END STOP	2
3	106864	30 AMP DC POWER RELAY	1
4	107540	24-10 AWG FUSE TERMINAL BLOCK	4
5	108459	2 AMP GMA FUSE	4

6.11 - 8kW 1PH 2-30A Twistlock 1-30A RV Outlet Package I

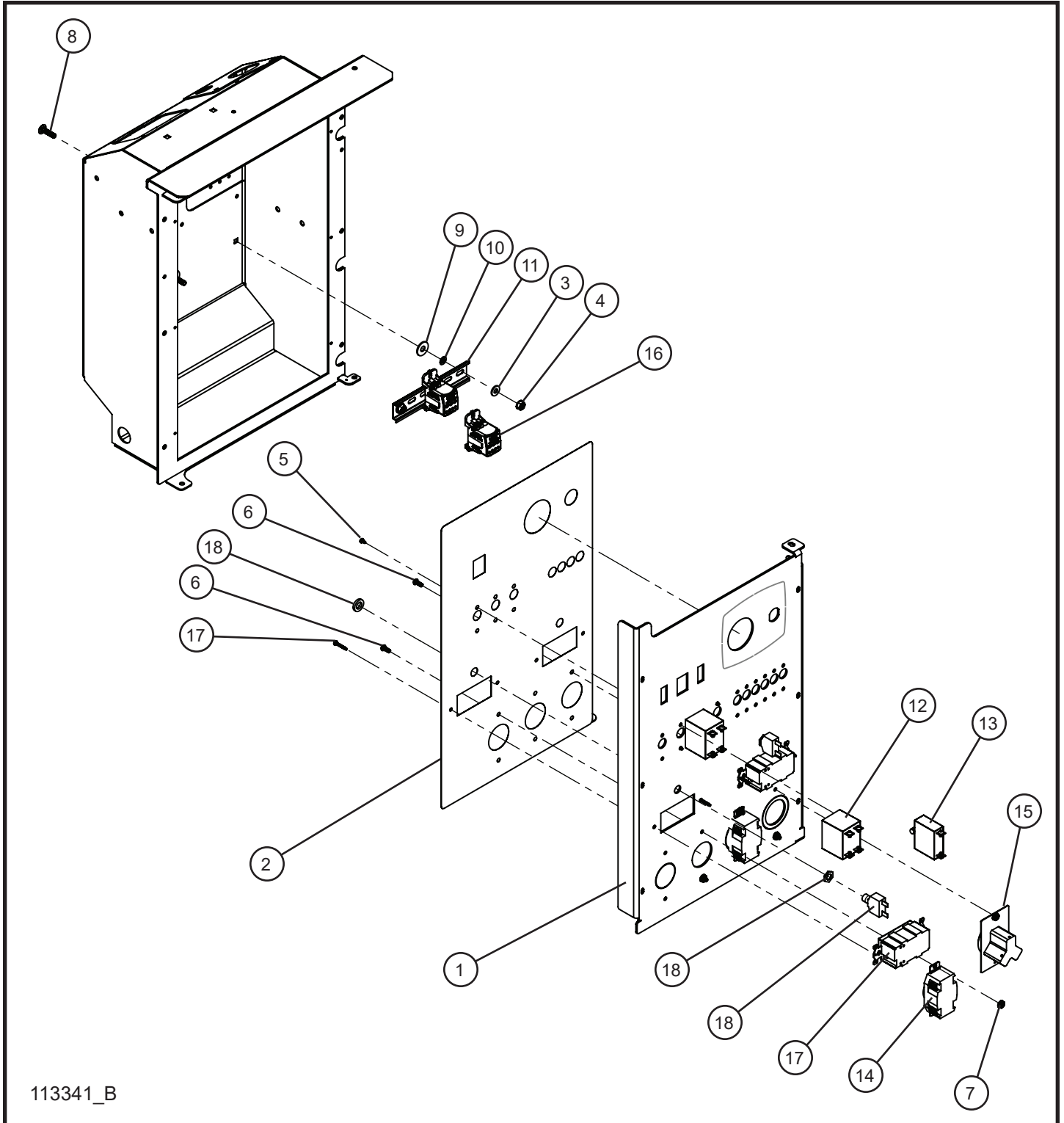

6.11 - 8kW 1PH 2-30A Twistlock 1-30A RV Outlet Package I

Item	Part No.	Part Description	Qty.
1	111223P	MAXI-LITE COMPONENT BOX LSC/KEY OUTLET PANEL	1
2	116384	MAXI-LITE OUTLET PANEL DECAL	1
3	047005	1/4 FLAT WASHER	2
4	044021	1/4-20 KEPS HEX NUT	2
5	041018	#6-32 x 1/4 PH-ROUND HEAD MACHINE SCREW	6
6	041021	#10-24 x 1/2 PH-ROUND HEAD MACHINE SCREW	6
7	044016	#10-24 KEPS HEX NUT	6
8	100342	1/4-20 x 1 CARRIAGE BOLT	2
9	047010	5/16 FLAT WASHER	2
10	101701	1/4 PUSH NUT	2
11	114488	DIN RAIL 6 INCH	1
12	330456	30A DPST CIRCUIT BREAKER	2
13	330472	15A SPST SWITCH	1
14	653102	30A 125-250V TWISTLOCK RECEPTACLE	2
15	680815	30A 125V RV OUTLET	1
16	104779	ERIFLEX DISTRIBUTION BLOCK	2
17	330499	20A GFCI RECEPTACLE	2
18	650138	20A PUSH BUTTON CIRCUIT BREAKER	2
NS	114027	MAXI-LITE 8kW 1 PHASE OUTLET PANEL SCHEMATIC	1

6.12 - 8kW 1PH 2-30A Twistlock 1-30A RV Outlet Package II

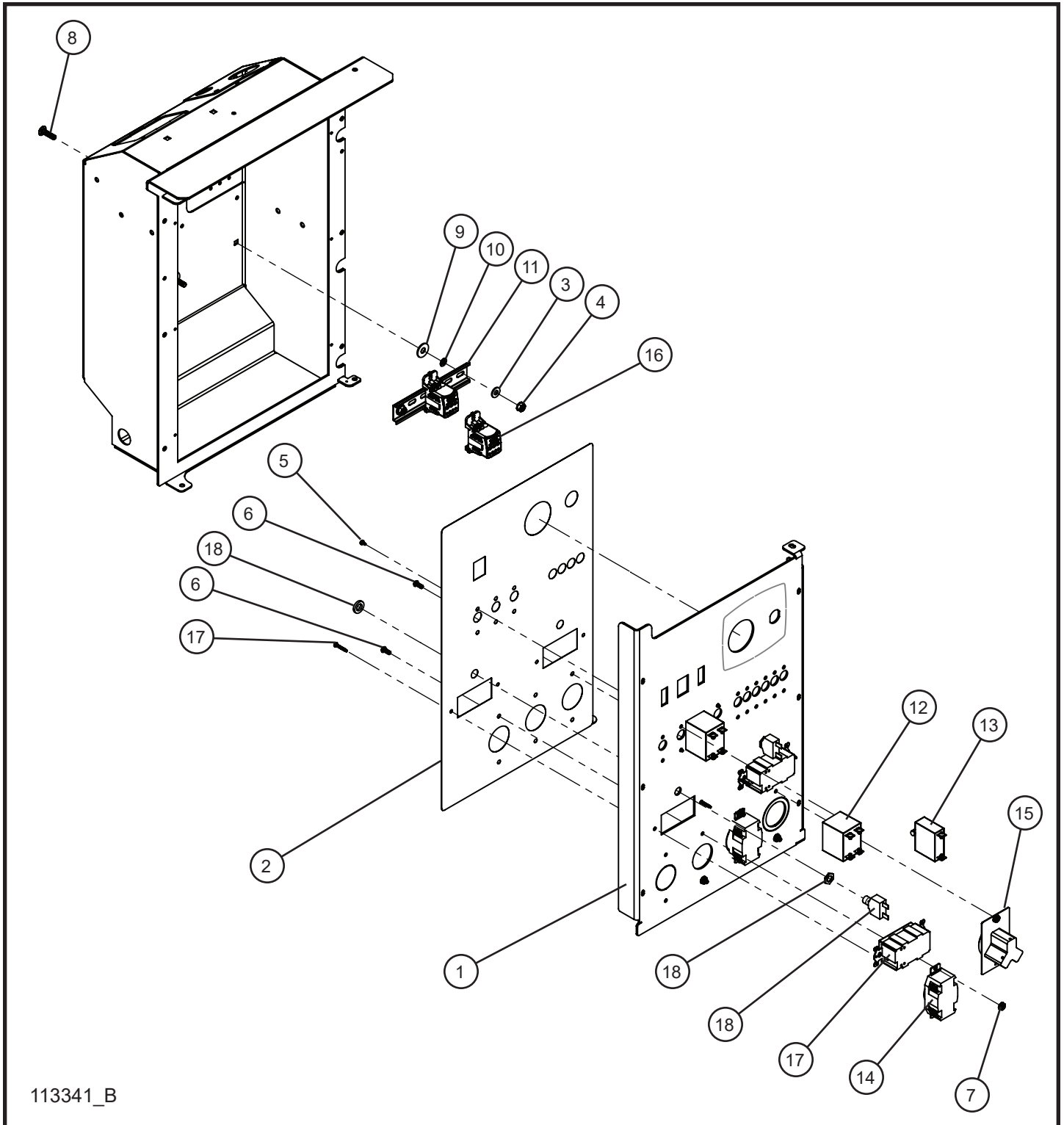

113341_B

6.12 - 8kW 1PH 2-30A Twistlock 1-30A RV Outlet Package II

Item	Part No.	Part Description	Qty.
1	117545P	MAXI-LITE COMPONENT BOX LSC/KEY OUTLET PANEL	1
2	116703	MAXI-LITE OUTLET PANEL DECAL	1
3	047005	1/4 FLAT WASHER	2
4	044021	1/4-20 KEPS HEX NUT	2
5	041018	#6-32 x 1/4 PH-ROUND HEAD MACHINE SCREW	6
6	041021	#10-24 x 1/2 PH-ROUND HEAD MACHINE SCREW	6
7	044016	#10-24 KEPS HEX NUT	6
8	100342	1/4-20 x 1 CARRIAGE BOLT	2
9	047010	5/16 FLAT WASHER	2
10	101701	1/4 PUSH NUT	2
11	114488	DIN RAIL 6 INCH	1
12	330456	30A DPST CIRCUIT BREAKER	2
13	330472	15A SPST SWITCH	1
14	653102	30A 125-250V TWISTLOCK RECEPTACLE	2
15	680815	30A 125V RV OUTLET	1
16	104779	ERIFLEX DISTRIBUTION BLOCK	2
17	330499	20A GFCI RECEPTACLE	2
18	650138	20A PUSH BUTTON CIRCUIT BREAKER	2
NS	114027	MAXI-LITE 8kW 1 PHASE OUTLET PANEL SCHEMATIC	1

6.13 - 8kW 1PH 2-30A Twistlock 1-30A RV BSB Outlet Package

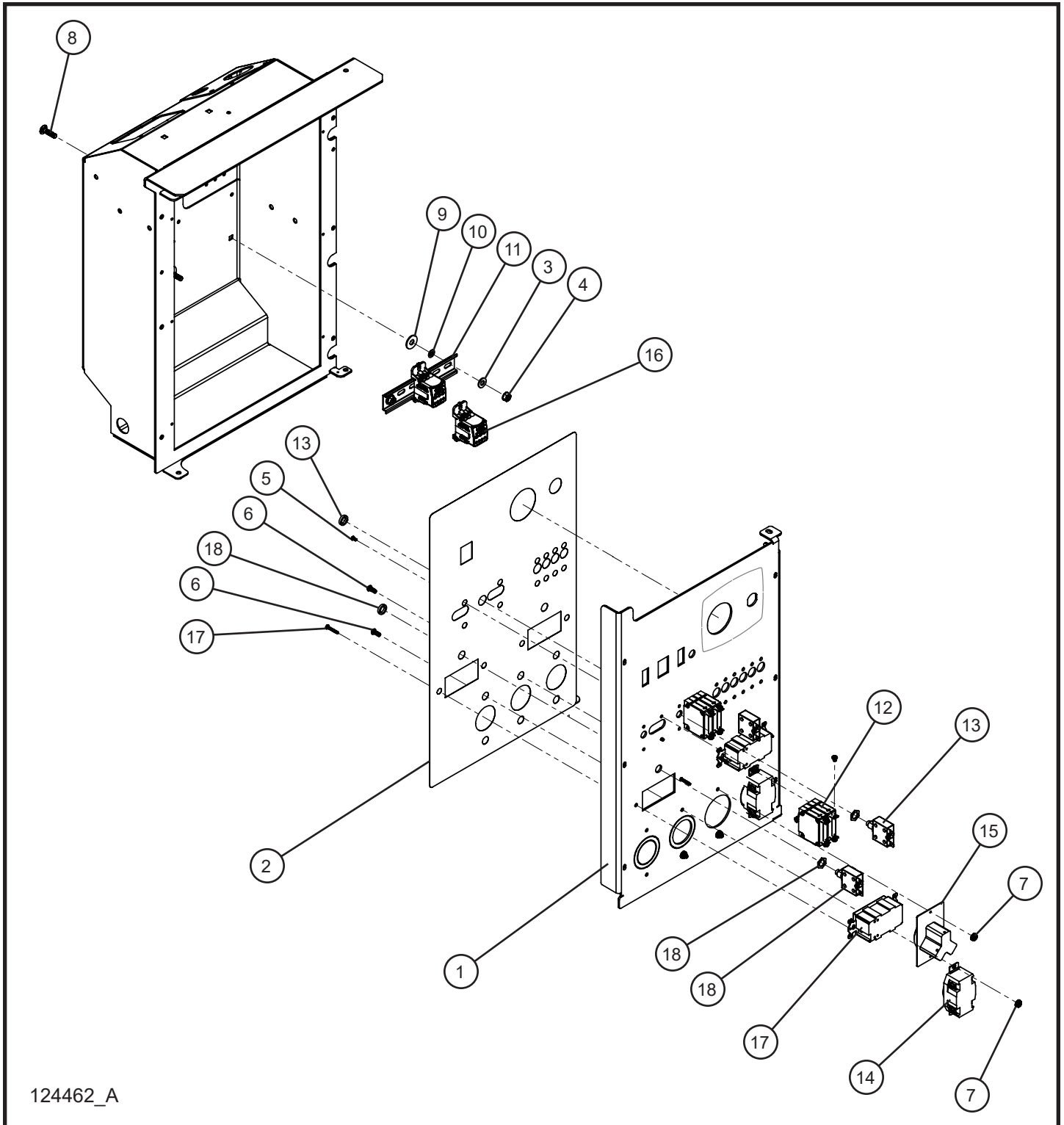

124462_A

6.13 - 8kW 1PH 2-30A Twistlock 1-30A RV BSB Outlet Package

Item	Part No.	Part Description	Qty.
1	124475P	OUTLET PANEL COMPONENT BOX LSC/KEY BSB MAXI II	1
2	123276	DECAL OUTLET PANEL BSB MAXI II	1
3	047005	1/4 FLAT WASHER	2
4	044021	1/4-20 KEPS HEX NUT	2
5	041252	M3 - 0.05MM X 6MM MACHINE SCREW	4
6	041021	#10-24 x 1/2 PH-ROUND HEAD MACHINE SCREW	6
7	044016	#10-24 KEPS HEX NUT	6
8	100342	1/4-20 x 1 CARRIAGE BOLT	2
9	047010	5/16 FLAT WASHER	2
10	101701	1/4 PUSH NUT	2
11	114488	DIN RAIL 6 INCH	1
12	123260	30AMP DOUBLE POLE CIRCUIT BREAKER	2
13	118662	BREAKER THERMAL PUSH BUTTON 30A 250VAC	1
14	653102	30A 125-250V TWISTLOCK RECEPTACLE	2
15	680815	30A 125V RV OUTLET	1
16	104779	ERIFLEX DISTRIBUTION BLOCK	2
17	330499	20A GFCI RECEPTACLE	2
18	118398	BREAKER THERMAL PUSH BUTTON 20A CSA	2
NS	124482	SCHEMATIC OUTLET PANEL 8KW 1-PHASE MAXI II	1

6.14 - 15/20kW 1PH 3-30A Twistlock 1-50A CS6369 Outlet Package I

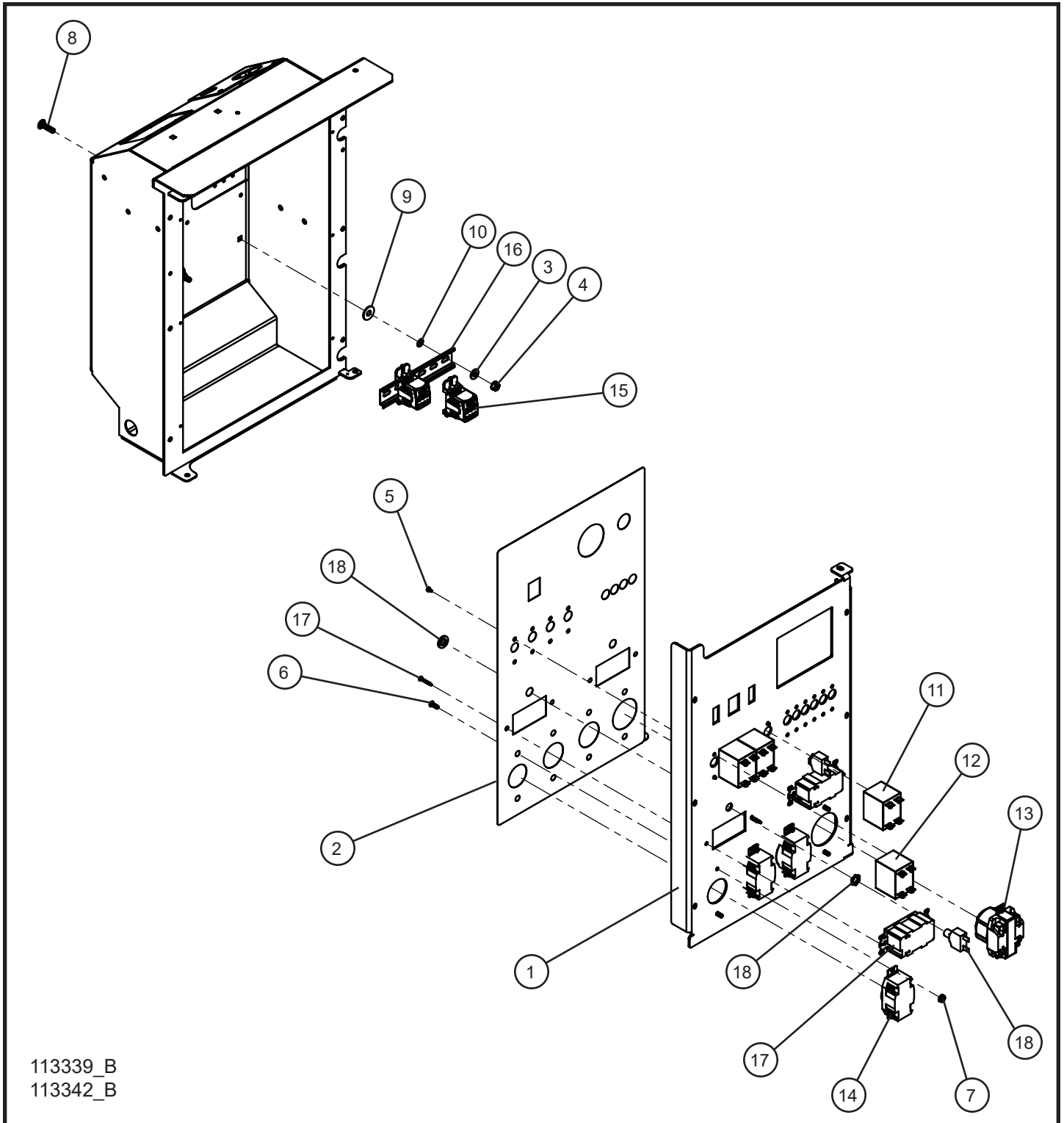

6.14 - 15/20kW 1PH 3-30A Twistlock 1-50A CS6369 Outlet Package I

Item	Part No.	Part Description	Qty.
1	111223P	MAXI-LITE COMPONENT BOX LSC/KEY OUTLET PANEL	1
	112565P	MAXI-LITE COMPONENT BOX DSE 4520 MK II OUTLET PANEL	1
2	116384	MAXI-LITE OUTLET PANEL DECAL	1
3	047005	1/4 FLAT WASHER	2
4	044021	1/4-20 KEPS HEX NUT	2
5	041018	#6-32 x 1/4 PH-ROUND HEAD MACHINE SCREW	8
6	041021	#10-24 x 1/2 PH-ROUND HEAD MACHINE SCREW	8
7	044016	#10-24 KEPS HEX NUT	8
8	100342	1/4-20 x 1 CARRIAGE BOLT	2
9	047010	5/16 FLAT WASHER	2
10	101701	1/4 PUSH NUT	2
11	353279	50A DPST CIRCUIT BREAKER	1
12	330456	30A DPST CIRCUIT BREAKER	3
13	104267	50A 125-250V CS6369 RECEPTACLE	1
14	653102	30A 125-250V TWISTLOCK RECEPTACLE	3
15	104779	ERIFLEX DISTRIBUTION BLOCK	2
16	114488	DIN RAIL 6 INCH	1
17	330499	20A GFCI RECEPTACLE	2
18	650138	20A PUSH BUTTON CIRCUIT BREAKER	2
NS	117524	50A CS6369 TO 50A RV NEMA INSTALLATION KIT	1
NS	114025	MAXI-LITE 15/20kW 1 PHASE OUTLET PANEL SCHEMATIC	1

6.15 - 15/20kW 1PH 3-30A Twistlock 1-50A CS6369 Outlet Package II

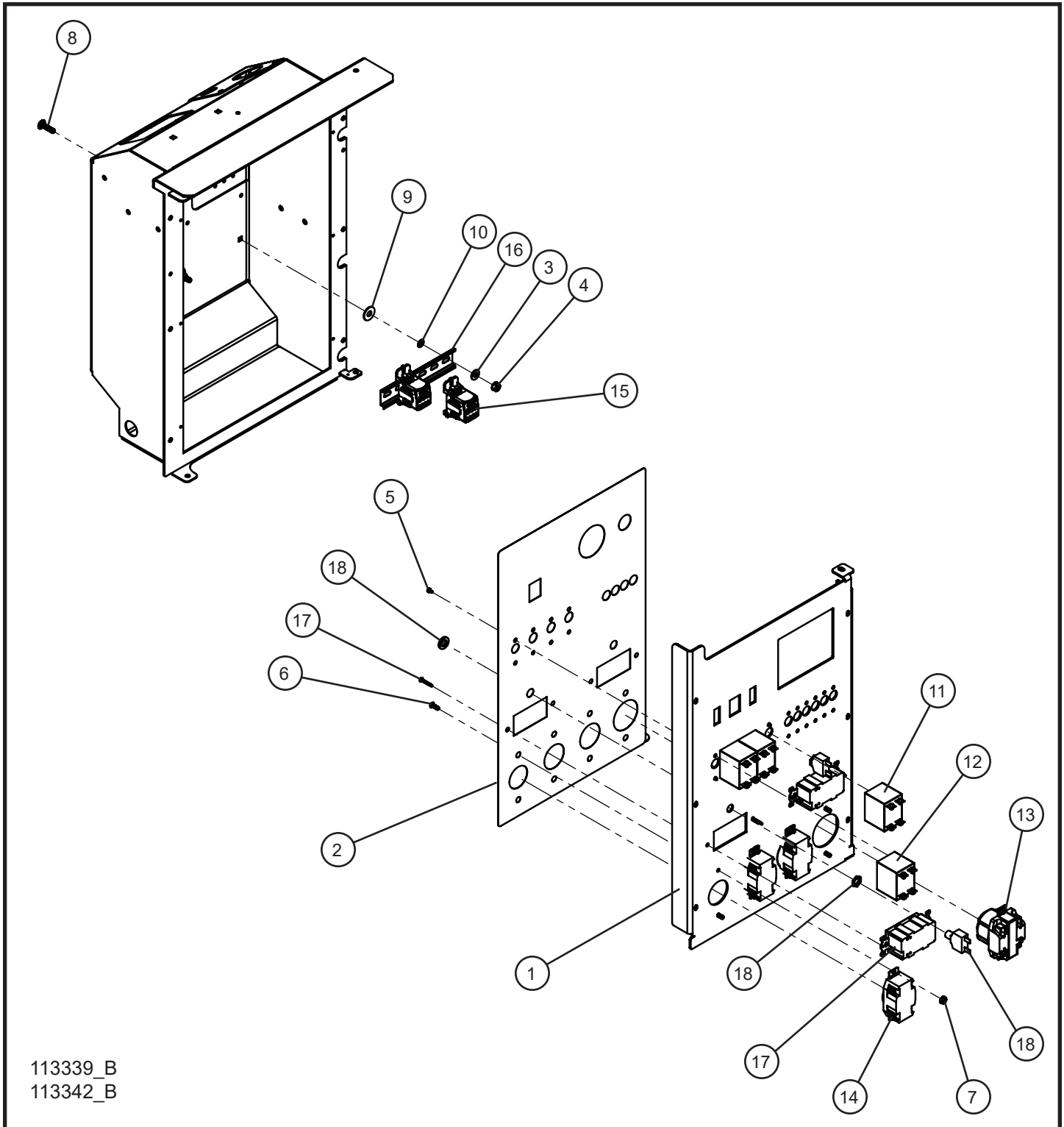

6.15 - 15/20kW 1PH 3-30A Twistlock 1-50A CS6369 Outlet Package II

Item	Part No.	Part Description	Qty.
1	117545P	MAXI-LITE COMPONENT BOX LSC/KEY OUTLET PANEL	1
	117546P	MAXI-LITE COMPONENT BOX DSE 4520 MK II OUTLET PANEL	1
2	116703	MAXI-LITE OUTLET PANEL DECAL	1
3	047005	1/4 FLAT WASHER	2
4	044021	1/4-20 KEPS HEX NUT	2
5	041018	#6-32 x 1/4 PH-ROUND HEAD MACHINE SCREW	8
6	041021	#10-24 x 1/2 PH-ROUND HEAD MACHINE SCREW	8
7	044016	#10-24 KEPS HEX NUT	8
8	100342	1/4-20 x 1 CARRIAGE BOLT	2
9	047010	5/16 FLAT WASHER	2
10	101701	1/4 PUSH NUT	2
11	353279	50A DPST CIRCUIT BREAKER	1
12	330456	30A DPST CIRCUIT BREAKER	3
13	104267	50A 125-250V CS6369 RECEPTACLE	1
14	653102	30A 125-250V TWISTLOCK RECEPTACLE	3
15	104779	ERIFLEX DISTRIBUTION BLOCK	2
16	114488	DIN RAIL 6 INCH	1
17	330499	20A GFCI RECEPTACLE	2
18	650138	20A PUSH BUTTON CIRCUIT BREAKER	2
NS	117524	50A CS6369 TO 50A RV NEMA INSTALLATION KIT	1
NS	114025	MAXI-LITE 15/20kW 1 PHASE OUTLET PANEL SCHEMATIC	1

6.16 - 15/20kW 1PH 3-30A Twistlock 1-50A CS6369 BSB Outlet Package

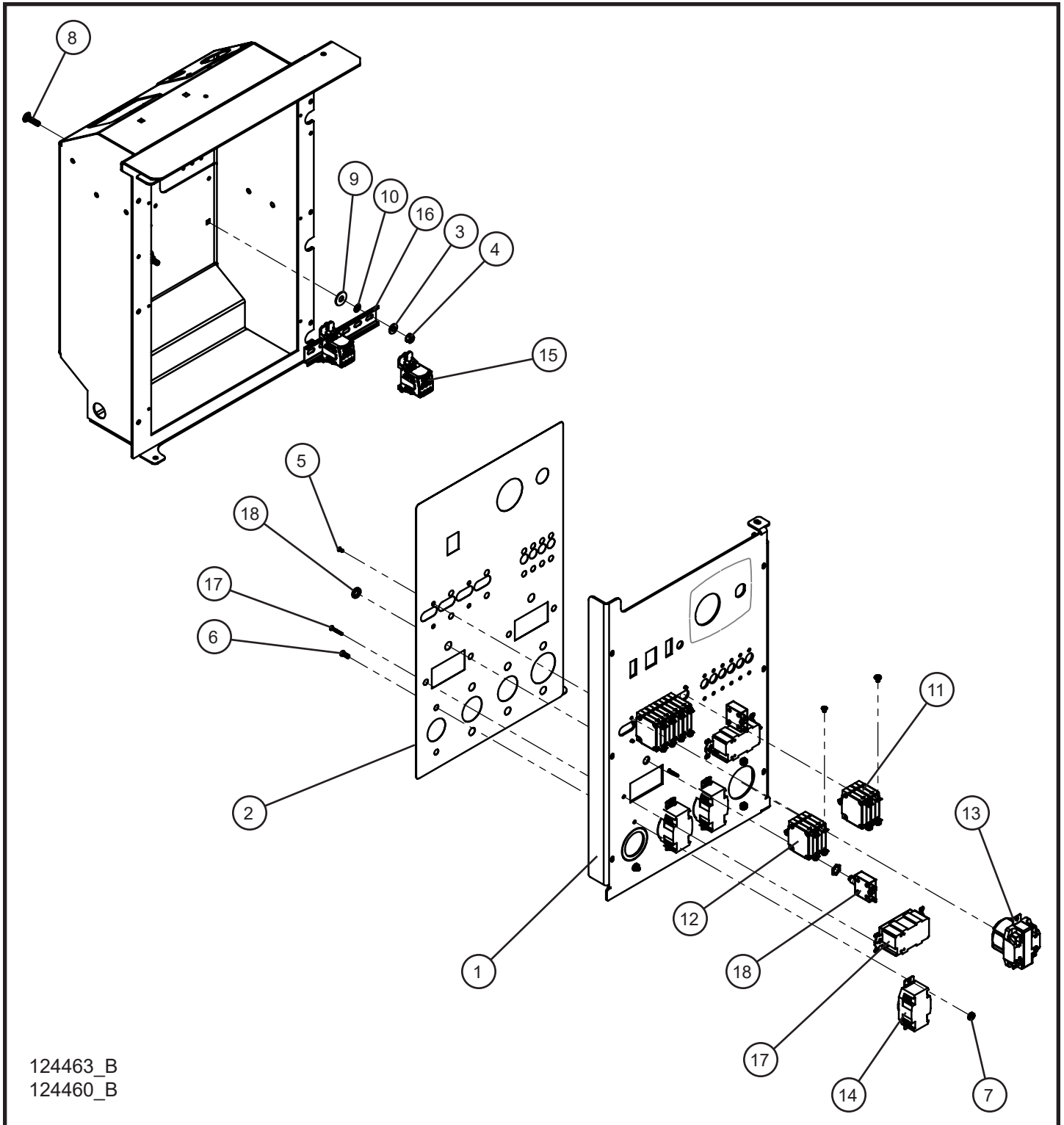

6.16 - 15/20kW 1PH 3-30A Twistlock 1-50A CS6369 BSB Outlet Package

Item	Part No.	Part Description	Qty.
1	124475P	OUTLET PANEL COMPONENT BOX LSC/KEY BSB MAXI II	1
	124476P	OUTLET PANEL COMPONENT BOX DEEP SEA BSB MAXI II	1
2	123276	DECAL OUTLET PANEL BSB MAXI II	1
3	047005	1/4 FLAT WASHER	2
4	044021	1/4-20 KEPS HEX NUT	2
5	041252	M3 - 0.05MM X 6MM MACHINE SCREW	8
6	041021	#10-24 x 1/2 PH-ROUND HEAD MACHINE SCREW	8
7	044016	#10-24 KEPS HEX NUT	8
8	100342	1/4-20 x 1 CARRIAGE BOLT	2
9	047010	5/16 FLAT WASHER	2
10	101701	1/4 PUSH NUT	2
11	123261	50AMP DOUBLE POLE CIRCUIT BREAKER	1
12	123260	30AMP DOUBLE POLE CIRCUIT BREAKER	3
13	104267	50A 125-250V CS6369 RECEPTACLE	1
14	653102	30A 125-250V TWISTLOCK RECEPTACLE	3
15	104779	ERIFLEX DISTRIBUTION BLOCK	2
16	114488	DIN RAIL 6 INCH	1
17	330499	20A GFCI RECEPTACLE	2
18	118398	BREAKER THERMAL PUSH BUTTON 20A CSA	2
NS	117524	50A CS6369 TO 50A RV NEMA INSTALLATION KIT	1
NS	114025	MAXI-LITE 15/20kW 1 PHASE OUTLET PANEL SCHEMATIC	1

6.17 - 15/20kW 3PH 4-30A Twistlock Outlet Package I

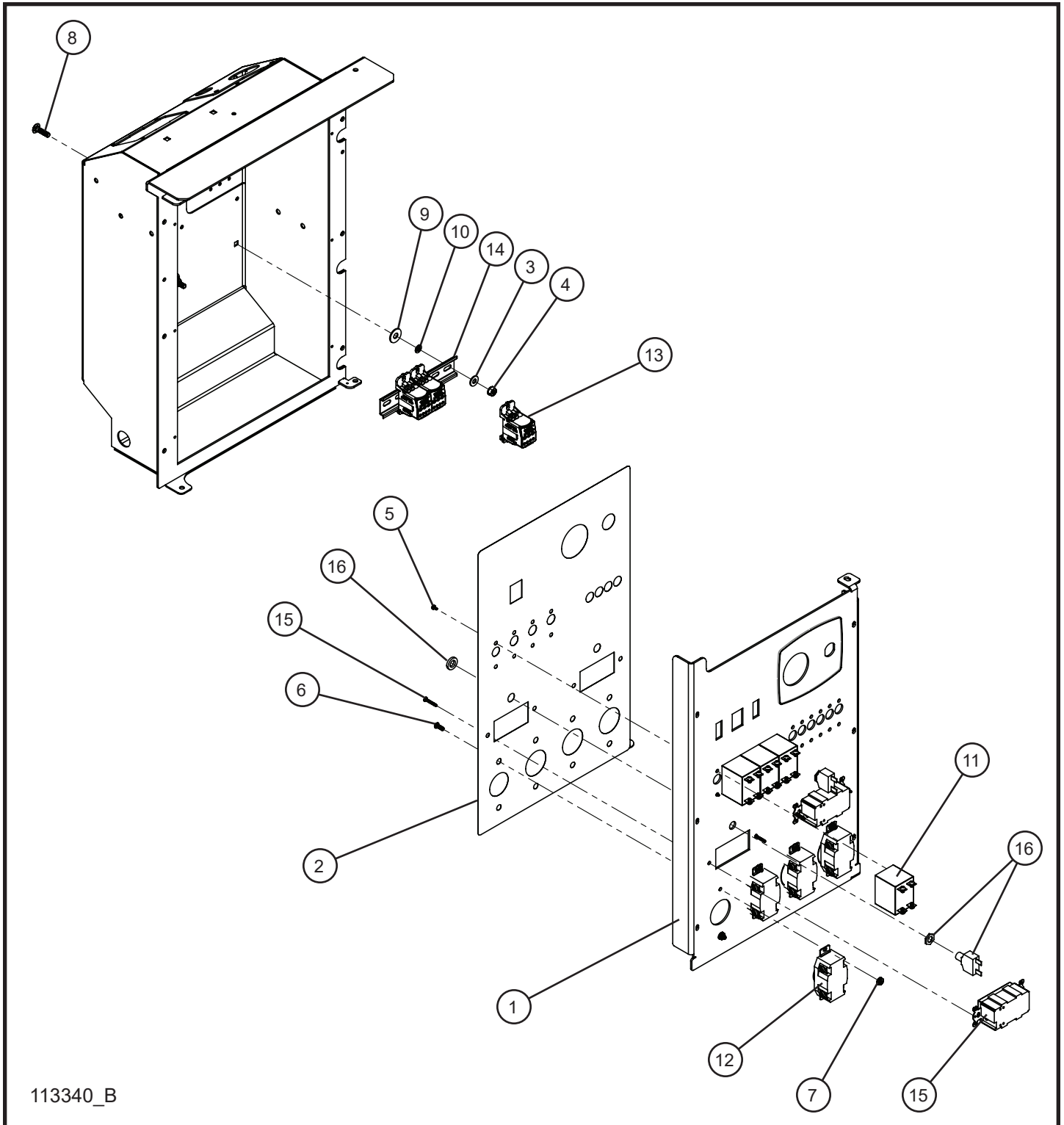

6.17 - 15/20kW 3PH 4-30A Twistlock Outlet Package I

Item	Part No.	Part Description	Qty.
1	111223P	MAXI-LITE COMPONENT BOX LSC/KEY OUTLET PANEL	1
	112565P	MAXI-LITE COMPONENT BOX DSE 4520 MK II OUTLET PANEL	1
2	116384	MAXI-LITE OUTLET PANEL DECAL	1
3	047005	1/4 FLAT WASHER	2
4	044021	1/4-20 KEPS HEX NUT	2
5	041018	#6-32 x 1/4 PH-ROUND HEAD MACHINE SCREW	8
6	041021	#10-24 x 1/2 PH-ROUND HEAD MACHINE SCREW	8
7	044016	#10-24 KEPS HEX NUT	8
8	100342	1/4-20 x 1 CARRIAGE BOLT	2
9	047010	5/16 FLAT WASHER	2
10	101701	1/4 PUSH NUT	2
11	330456	30A DPST CIRCUIT BREAKER	4
12	653102	30A 125-250V TWISTLOCK RECEPTACLE	4
13	104779	ERIFLEX DISTRIBUTION BLOCK	3
14	114488	DIN RAIL 6 INCH	1
15	330499	20A GFCI RECEPTACLE	2
16	650138	20A PUSH BUTTON CIRCUIT BREAKER	2
NS	114026	MAXI-LITE 20kW 3 PHASE OUTLET PANEL SCHEMATIC	1

6.18 - 15/20kW 3PH 4-30A Twistlock Outlet Package II

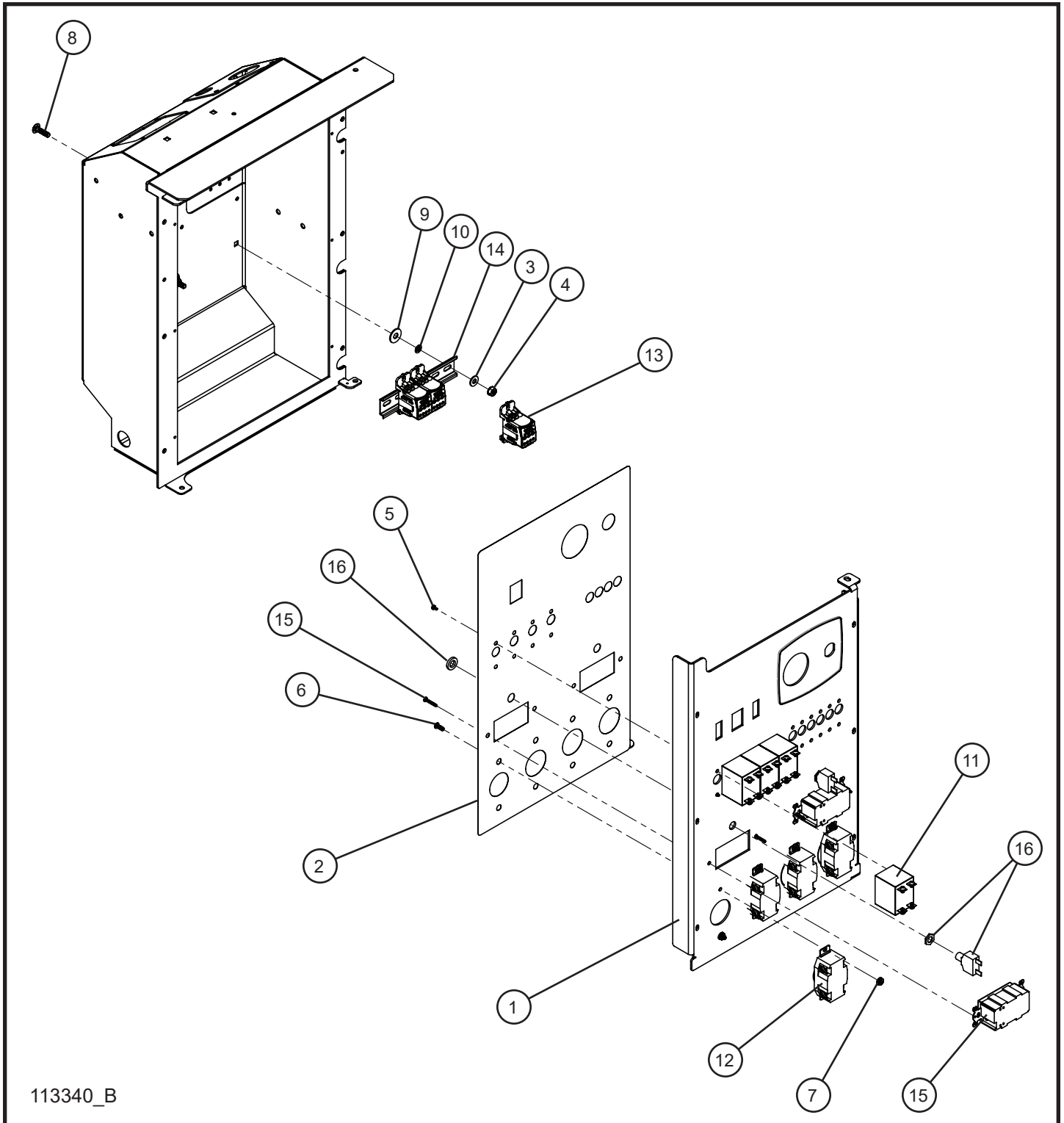

6.18 - 15/20kW 3PH 4-30A Twistlock Outlet Package II

Item	Part No.	Part Description	Qty.
1	117545P	MAXI-LITE COMPONENT BOX LSC/KEY OUTLET PANEL	1
	117546P	MAXI-LITE COMPONENT BOX DSE 4520 MK II OUTLET PANEL	1
2	116703	MAXI-LITE OUTLET PANEL DECAL	1
3	047005	1/4 FLAT WASHER	2
4	044021	1/4-20 KEPS HEX NUT	2
5	041018	#6-32 x 1/4 PH-ROUND HEAD MACHINE SCREW	8
6	041021	#10-24 x 1/2 PH-ROUND HEAD MACHINE SCREW	8
7	044016	#10-24 KEPS HEX NUT	8
8	100342	1/4-20 x 1 CARRIAGE BOLT	2
9	047010	5/16 FLAT WASHER	2
10	101701	1/4 PUSH NUT	2
11	330456	30A DPST CIRCUIT BREAKER	4
12	653102	30A 125-250V TWISTLOCK RECEPTACLE	4
13	104779	ERIFLEX DISTRIBUTION BLOCK	3
14	114488	DIN RAIL 6 INCH	1
15	330499	20A GFCI RECEPTACLE	2
16	650138	20A PUSH BUTTON CIRCUIT BREAKER	2
NS	114026	MAXI-LITE 20kW 3 PHASE OUTLET PANEL SCHEMATIC	1

6.19 - 15/20kW 3PH 4-30A Twistlock BSB Outlet Package

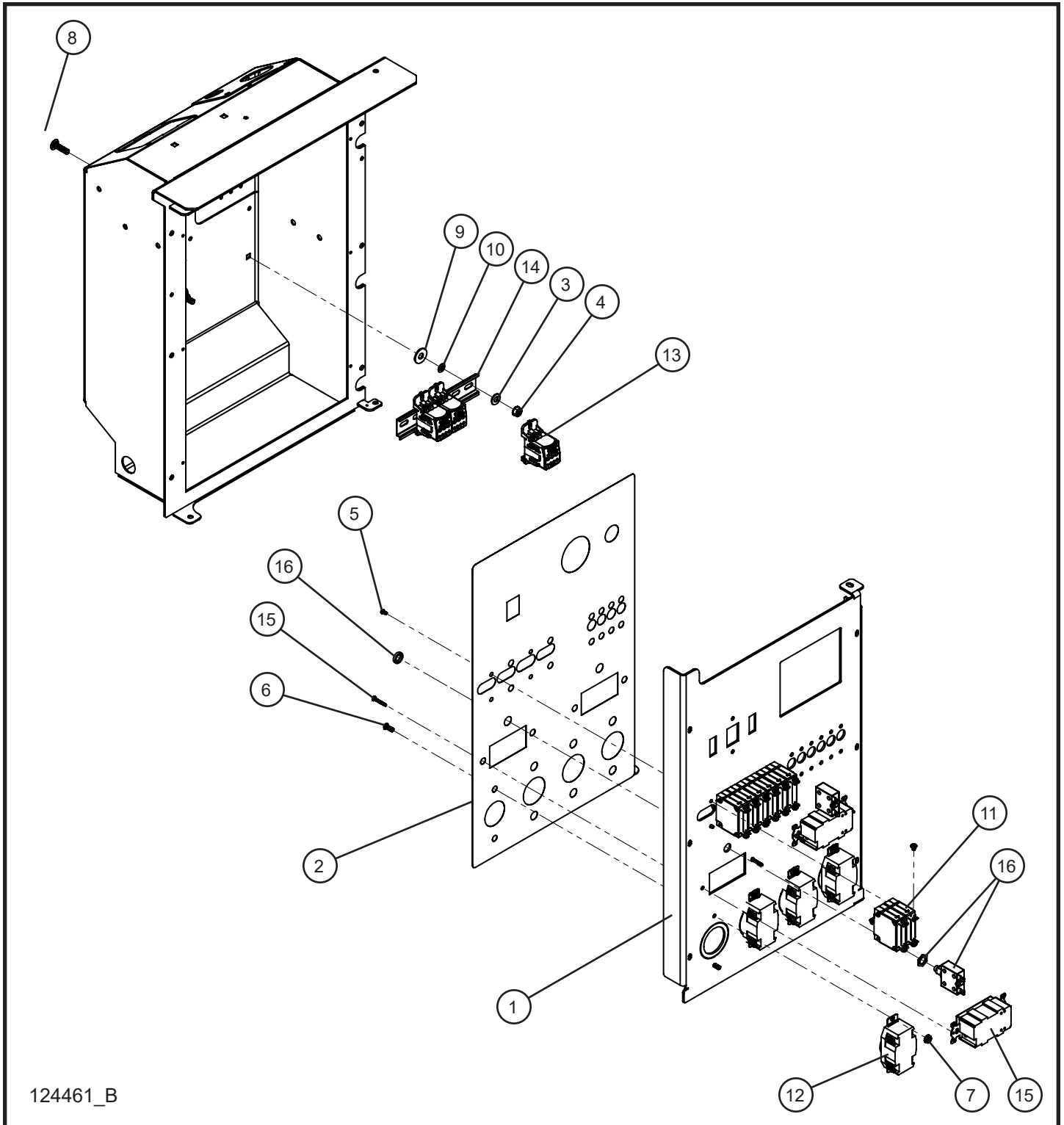

6.19 - 15/20kW 3PH 4-30A Twistlock BSB Outlet Package

Item	Part No.	Part Description	Qty.
1	124475P	OUTLET PANEL COMPONENT BOX LSC/KEY BSB MAXI II	1
	124476P	OUTLET PANEL COMPONENT BOX DEEP SEA BSB MAXI II	1
2	123276	DECAL OUTLET PANEL BSB MAXI II	1
3	047005	1/4 FLAT WASHER	2
4	044021	1/4-20 KEPS HEX NUT	2
5	041252	M3 - 0.05MM X 6MM MACHINE SCREW	8
6	041021	#10-24 x 1/2 PH-ROUND HEAD MACHINE SCREW	8
7	044016	#10-24 KEPS HEX NUT	8
8	100342	1/4-20 x 1 CARRIAGE BOLT	2
9	047010	5/16 FLAT WASHER	2
10	101701	1/4 PUSH NUT	2
11	123260	30AMP DOUBLE POLE CIRCUIT BREAKER	4
12	653102	30A 125-250V TWISTLOCK RECEPTACLE	4
13	104779	ERIFLEX DISTRIBUTION BLOCK	3
14	114488	DIN RAIL 6 INCH	1
15	330499	20A GFCI RECEPTACLE	2
16	118398	BREAKER THERMAL PUSH BUTTON 20A CSA	2
NS	114026	MAXI-LITE 20kW 3 PHASE OUTLET PANEL SCHEMATIC	1

6.20 - 15/20kW 1PH 2-Twistlock 1-RV 1-NEMA Outlet Package I

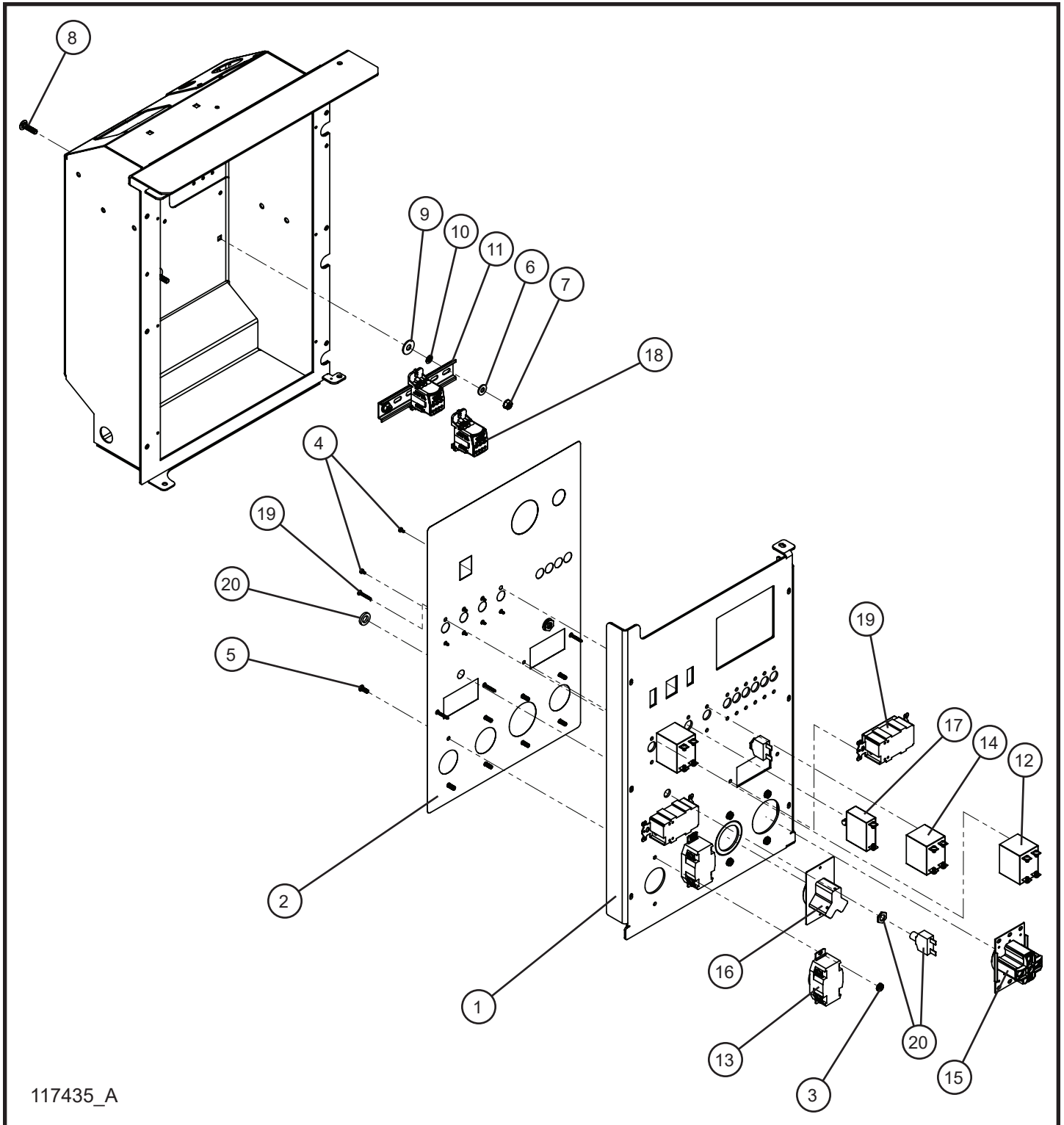

6.20 - 15/20kW 1PH 2-Twistlock 1-RV 1-NEMA Outlet Package I

Item	Part No.	Part Description	Qty.
1	111223P	MAXI-LITE COMPONENT BOX LSC/KEY OUTLET PANEL	1
	112565P	MAXI-LITE COMPONENT BOX DSE 4520 MK II OUTLET PANEL	1
2	116384	MAXI-LITE OUTLET PANEL DECAL	1
3	044016	#10-24 KEPS HEX NUT	8
4	041018	#6-32 x 1/4 PH-ROUND HEAD MACHINE SCREW	8
5	041021	#10-24 x 1/2 PH-ROUND HEAD MACHINE SCREW	8
6	047005	1/4 FLAT WASHER	2
7	044021	1/4-20 KEPS HEX NUT	2
8	100342	1/4-20 x 1 CARRIAGE BOLT	2
9	047010	5/16 FLAT WASHER	2
10	101701	1/4 PUSH NUT	2
11	114488	DIN RAIL 6 INCH	1
12	330456	30A DPST CIRCUIT BREAKER	2
13	653102	30A 125-250V TWISTLOCK RECEPTACLE	2
14	353279	50A DPST CIRCUIT BREAKER	1
15	022351	50A 250V NEMA 14-50R RECEPTACLE	1
16	680815	30A 125V RV OUTLET	1
17	330472	30A SPST CIRCUIT BREAKER	2
18	104779	ERIFLEX DISTRIBUTION BLOCK	3
19	330499	20A GFCI RECEPTACLE	2
20	650138	20A PUSH BUTTON CIRCUIT BREAKER	2
NS	117452	MAXI-LITE 1-NEMA 1-RV 2-TL OUTLET PANEL SCHEMATIC	1

6.21 - 15/20kW 1PH 2-Twistlock 1-RV 1-NEMA Outlet Package II

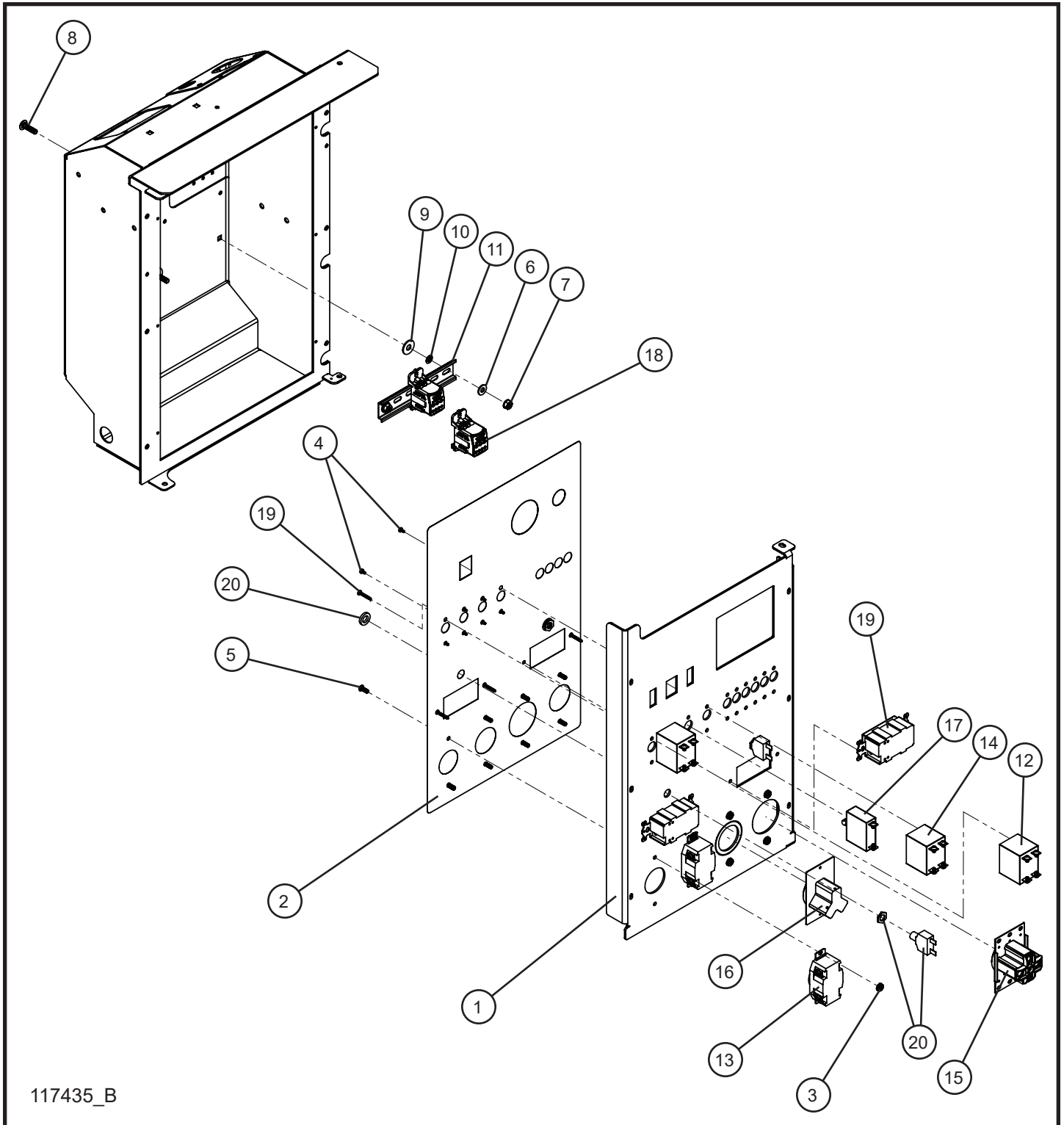

6.21 - 15/20kW 1PH 2-Twistlock 1-RV 1-NEMA Outlet Package II

Item	Part No.	Part Description	Qty.
1	117545P	MAXI-LITE COMPONENT BOX LSC/KEY OUTLET PANEL	1
	117546P	MAXI-LITE COMPONENT BOX DSE 4520 MK II OUTLET PANEL	1
2	116703	MAXI-LITE OUTLET PANEL DECAL	1
3	044016	#10-24 KEPS HEX NUT	8
4	041018	#6-32 x 1/4 PH-ROUND HEAD MACHINE SCREW	8
5	041021	#10-24 x 1/2 PH-ROUND HEAD MACHINE SCREW	8
6	047005	1/4 FLAT WASHER	2
7	044021	1/4-20 KEPS HEX NUT	2
8	100342	1/4-20 x 1 CARRIAGE BOLT	2
9	047010	5/16 FLAT WASHER	2
10	101701	1/4 PUSH NUT	2
11	114488	DIN RAIL 6 INCH	1
12	330456	30A DPST CIRCUIT BREAKER	2
13	653102	30A 125-250V TWISTLOCK RECEPTACLE	2
14	353279	50A DPST CIRCUIT BREAKER	1
15	022351	50A 250V NEMA 14-50R RECEPTACLE	1
16	680815	30A 125V RV OUTLET	1
17	330472	30A SPST CIRCUIT BREAKER	2
18	104779	ERIFLEX DISTRIBUTION BLOCK	3
19	330499	20A GFCI RECEPTACLE	2
20	650138	20A PUSH BUTTON CIRCUIT BREAKER	2
NS	117452	MAXI-LITE 1-NEMA 1-RV 2-TL OUTLET PANEL SCHEMATIC	1

6.22 - 15/20kW 1PH 2-Twistlock 1-RV 1-NEMA BSB Outlet Package

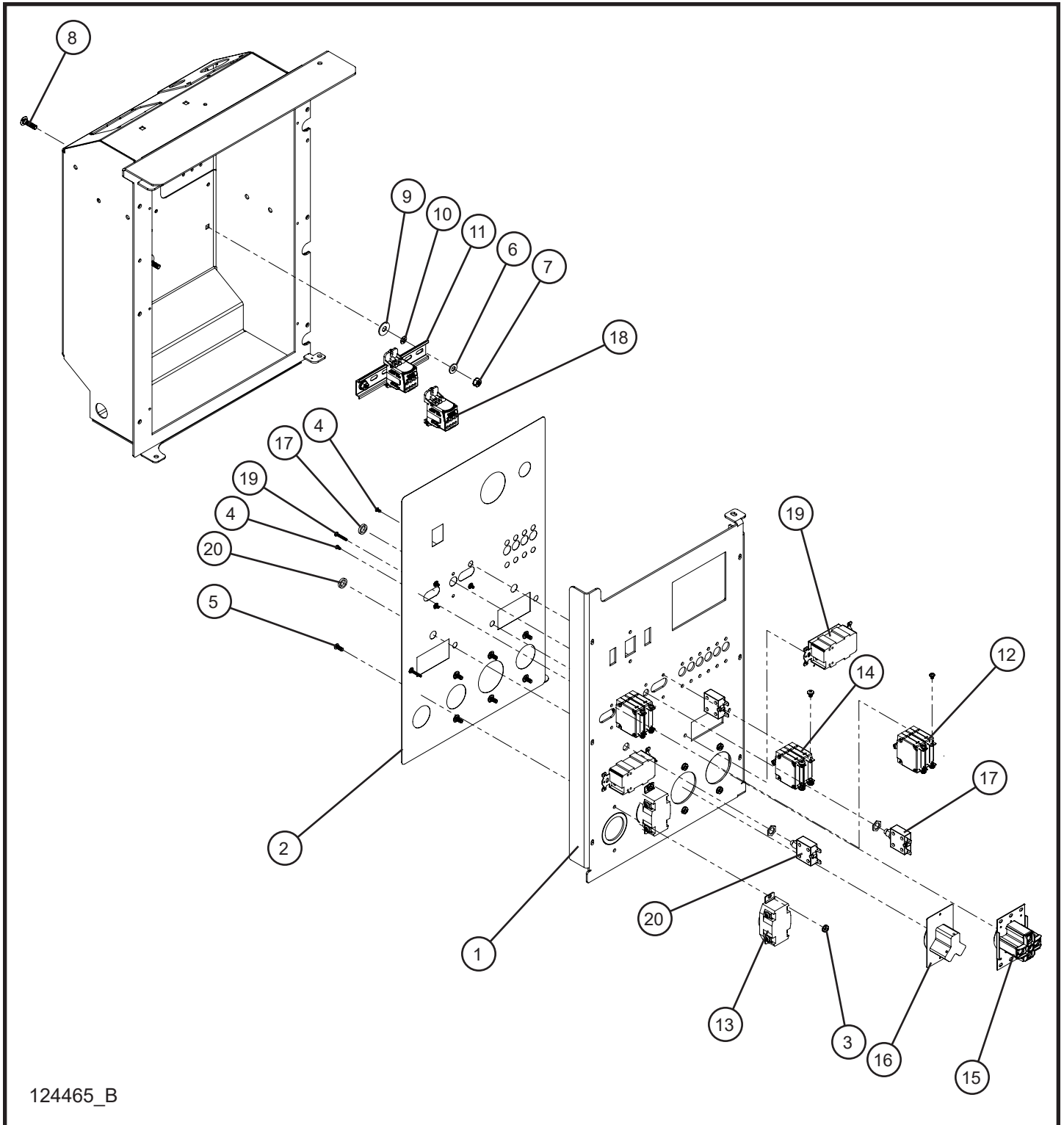

6.22 - 15/20kW 1PH 2-Twistlock 1-RV 1-NEMA BSB Outlet Package

Item	Part No.	Part Description	Qty.
1	124475P	OUTLET PANEL COMPONENT BOX LSC/KEY BSB MAXI II	1
	124476P	OUTLET PANEL COMPONENT BOX DEEP SEA BSB MAXI II	1
2	123276	DECAL OUTLET PANEL BSB MAXI II	1
3	044016	#10-24 KEPS HEX NUT	8
4	041252	M3 - 0.05MM X 6MM MACHINE SCREW	6
5	041021	#10-24 x 1/2 PH-ROUND HEAD MACHINE SCREW	8
6	047005	1/4 FLAT WASHER	2
7	044021	1/4-20 KEPS HEX NUT	2
8	100342	1/4-20 x 1 CARRIAGE BOLT	2
9	047010	5/16 FLAT WASHER	2
10	101701	1/4 PUSH NUT	2
11	114488	DIN RAIL 6 INCH	1
12	123260	30AMP DOUBLE POLE CIRCUIT BREAKER	2
13	653102	30A 125-250V TWISTLOCK RECEPTACLE	2
14	123261	50AMP DOUBLE POLE CIRCUIT BREAKER	1
15	022351	50A 250V NEMA 14-50R RECEPTACLE	1
16	680815	30A 125V RV OUTLET	1
17	118662	BREAKER THERMAL PUSH BUTTON 30A 250VAC	2
18	104779	ERIFLEX DISTRIBUTION BLOCK	3
19	330499	20A GFCI RECEPTACLE	2
20	118398	BREAKER THERMAL PUSH BUTTON 20A CSA	2
NS	124483	SCHEMATIC OUTLET PANEL 1-50A RV, 1-30A RV, 2-30A TL, MAXI II	1

6.23 - 15/20kW 1PH 2-30A RV 2-50A NEMA Outlet Package

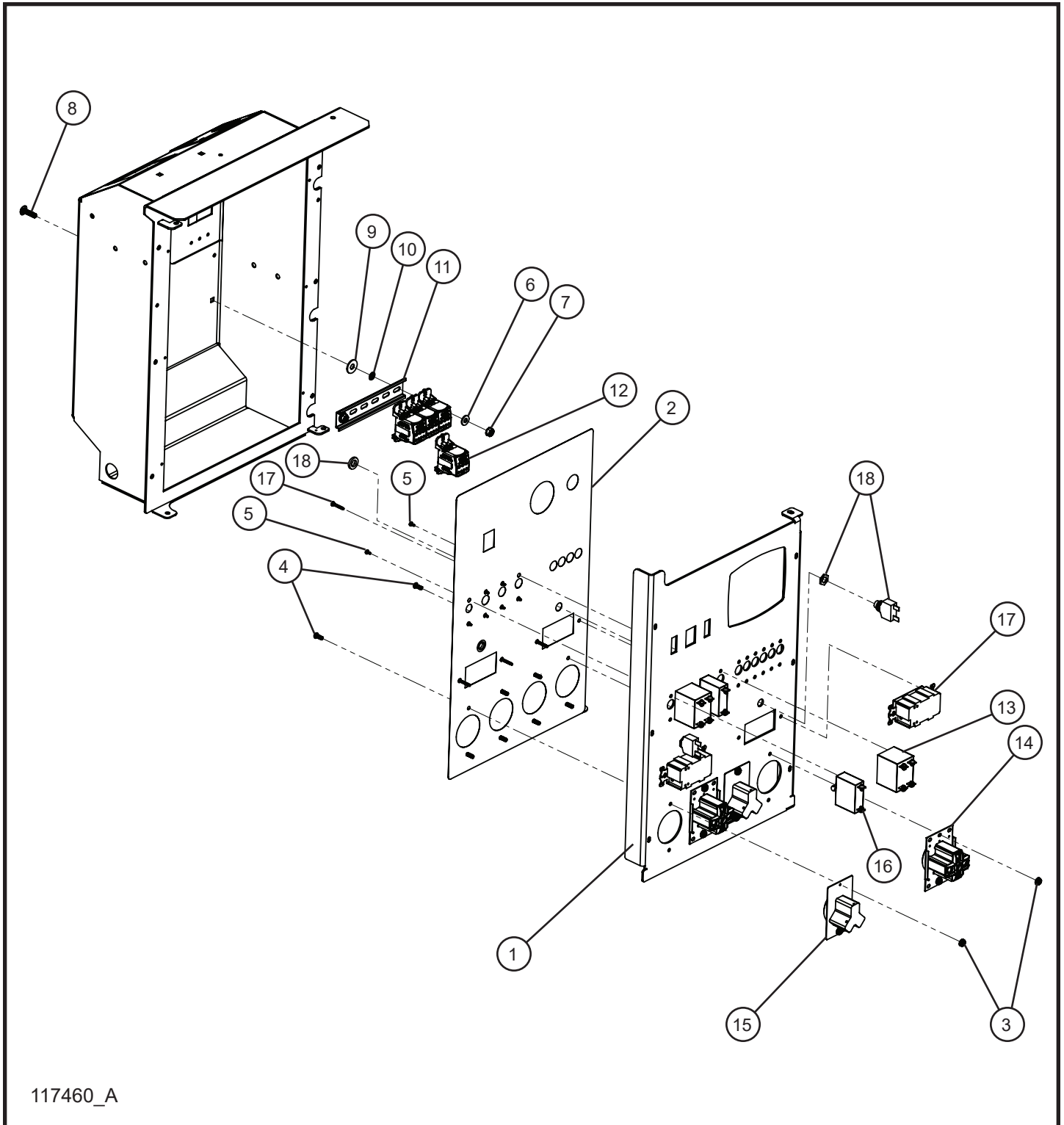

117460_A

6.23 - 15/20kW 1PH 2-30A RV 2-50A NEMA Outlet Package

Item	Part No.	Part Description	Qty.
1	117545P	MAXI-LITE COMPONENT BOX LSC/KEY OUTLET PANEL	1
	117546P	MAXI-LITE COMPONENT BOX DSE 4520 MK II OUTLET PANEL	1
2	116703	MAXI-LITE OUTLET PANEL DECAL	1
3	044016	#10-24 KEPS HEX NUT	8
4	041021	#10-24 x 1/2 PH-ROUND HEAD MACHINE SCREW	8
5	041018	#6-32 x 1/4 PH-ROUND HEAD MACHINE SCREW	8
6	047005	1/4 FLAT WASHER	2
7	044021	1/4-20 KEPS HEX NUT	2
8	100342	1/4-20 x 1 CARRIAGE BOLT	2
9	047010	5/16 FLAT WASHER	2
10	101701	1/4 PUSH NUT	2
11	114488	DIN RAIL 6 INCH	1
12	104779	ERIFLEX DISTRIBUTION BLOCK	4
13	353279	50A DPST CIRCUIT BREAKER	2
14	022351	50A 250V NEMA 14-50R RECEPTACLE	2
15	680815	30A 125V RV OUTLET	2
16	330472	30A SPST CIRCUIT BREAKER	2
17	330499	20A GFCI RECEPTACLE	2
18	650138	20A PUSH BUTTON CIRCUIT BREAKER	2
NS	117461	MAXI-LITE 2-RV 2-NEMA 2-GFCI OUTLET PANEL SCHEMATIC	1

6.24 - 15/20kW 1PH 2-30A RV 2-50A NEMA BSB Outlet Package

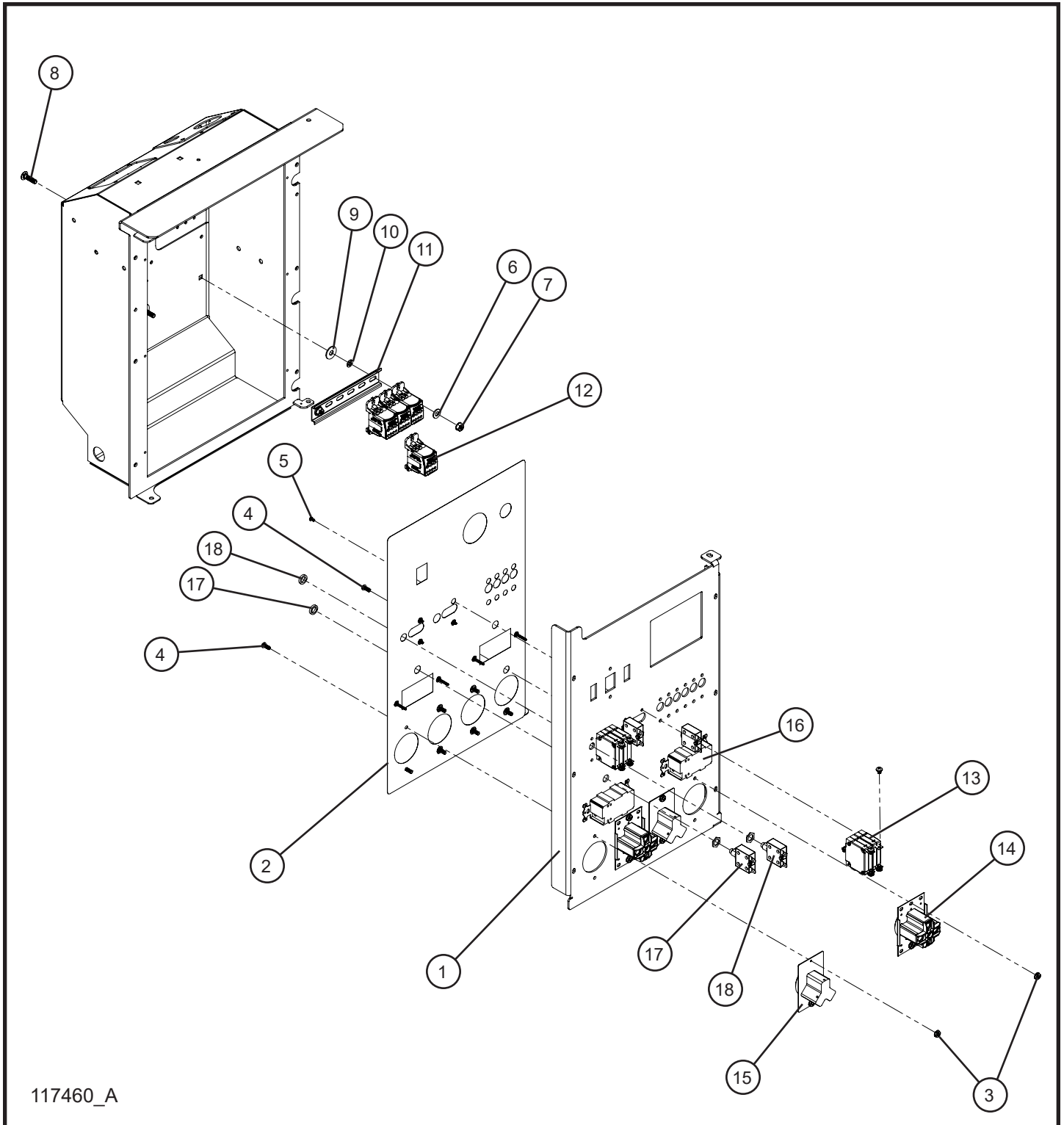

117460_A

6.24 - 15/20kW 1PH 2-30A RV 2-50A NEMA BSB Outlet Package

Item	Part No.	Part Description	Qty.
1	117545P	MAXI-LITE COMPONENT BOX LSC/KEY OUTLET PANEL	1
	117546P	MAXI-LITE COMPONENT BOX DSE 4520 MK II OUTLET PANEL	1
2	116703	MAXI-LITE OUTLET PANEL DECAL	1
3	044016	#10-24 KEPS HEX NUT	8
4	041021	#10-24 x 1/2 PH-ROUND HEAD MACHINE SCREW	8
5	041252	M3 - 0.05MM X 6MM MACHINE SCREW	8
6	047005	1/4 FLAT WASHER	2
7	044021	1/4-20 KEPS HEX NUT	2
8	100342	1/4-20 x 1 CARRIAGE BOLT	2
9	047010	5/16 FLAT WASHER	2
10	101701	1/4 PUSH NUT	2
11	114488	DIN RAIL 6 INCH	1
12	104779	ERIFLEX DISTRIBUTION BLOCK	4
13	123261	50AMP DOUBLE POLE CIRCUIT BREAKER	2
14	022351	50A 250V NEMA 14-50R RECEPTACLE	2
15	680815	30A 125V RV OUTLET	2
16	330499	20A GFCI RECEPTACLE	2
17	118398	BREAKER THERMAL PUSH BUTTON 20A CSA	2
18	118662	BREAKER THERMAL PUSH BUTTON 30A 250VAC	2
NS	124484	SCHEMATIC OUTLET PANEL 2-50A RV, 2-30A RV, 2-GFCI MAXI II	1

6.25 - Tower Rocker Switch and Interior Work Light

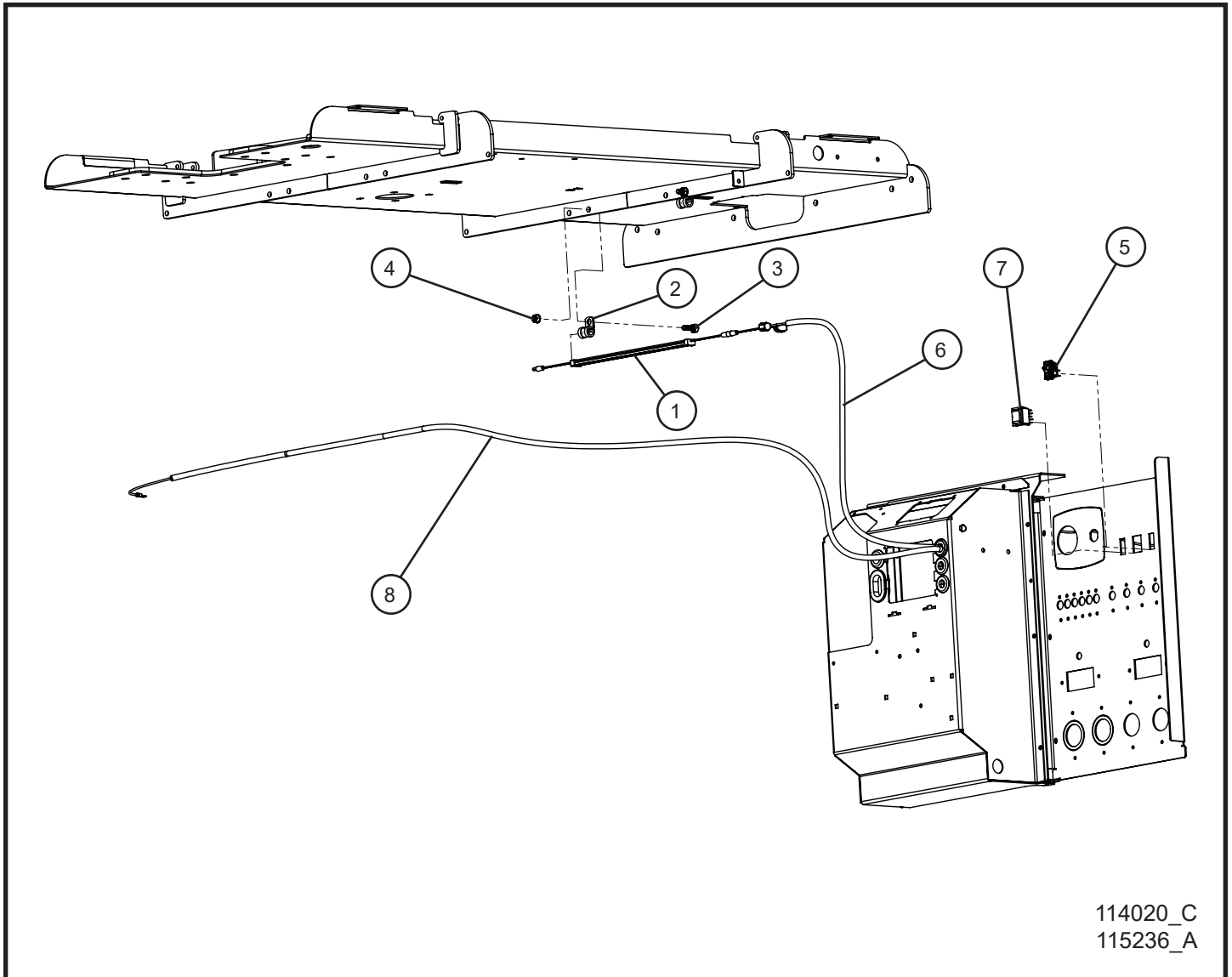

6.25 - Tower Rocker Switch and Interior Work Light

Item	Part No.	Part Description	Qty.
1	104820	12 INCH LED LIGHT	1
2	022018	#8 CUSH CLAMP	2
3	046050	5/16-18 x 1 HEX HEAD BOLT	2
4	044031	5/16-18 KEPS HEX NUT	2
5	113541	ON/OFF SPST ROCKER SWITCH	1
6	115248	MAXI-LITE INTERIOR LIGHT 16/2 CORD x 48 INCHES	1
7	113542	ON/OFF/ON DPDT ROCKER SWITCH	1
8	114031	MAXI-LITE HYDRAULIC SWITCH 16/2 CORD x 109 INCHES	1
NS	103864	FUSE HOLDER INLINE BLADE	1
NS	104990	2 AMP ATO/ATC BLADE FUSE	1
NS	115247	MAXI-LITE INTERIOR WORK LIGHT WIRE SCHEMATIC	1
NS	117947	MAXI-LITE ISUZU INTERIOR WORK LIGHT WIRE SCHEMATIC	1
NS	113143	HYDRAULIC VERTICAL KEY SWITCH POWERED SCHEMATIC	1

7.1 - SLS Key Start Chief Fuse Box Assembly Group

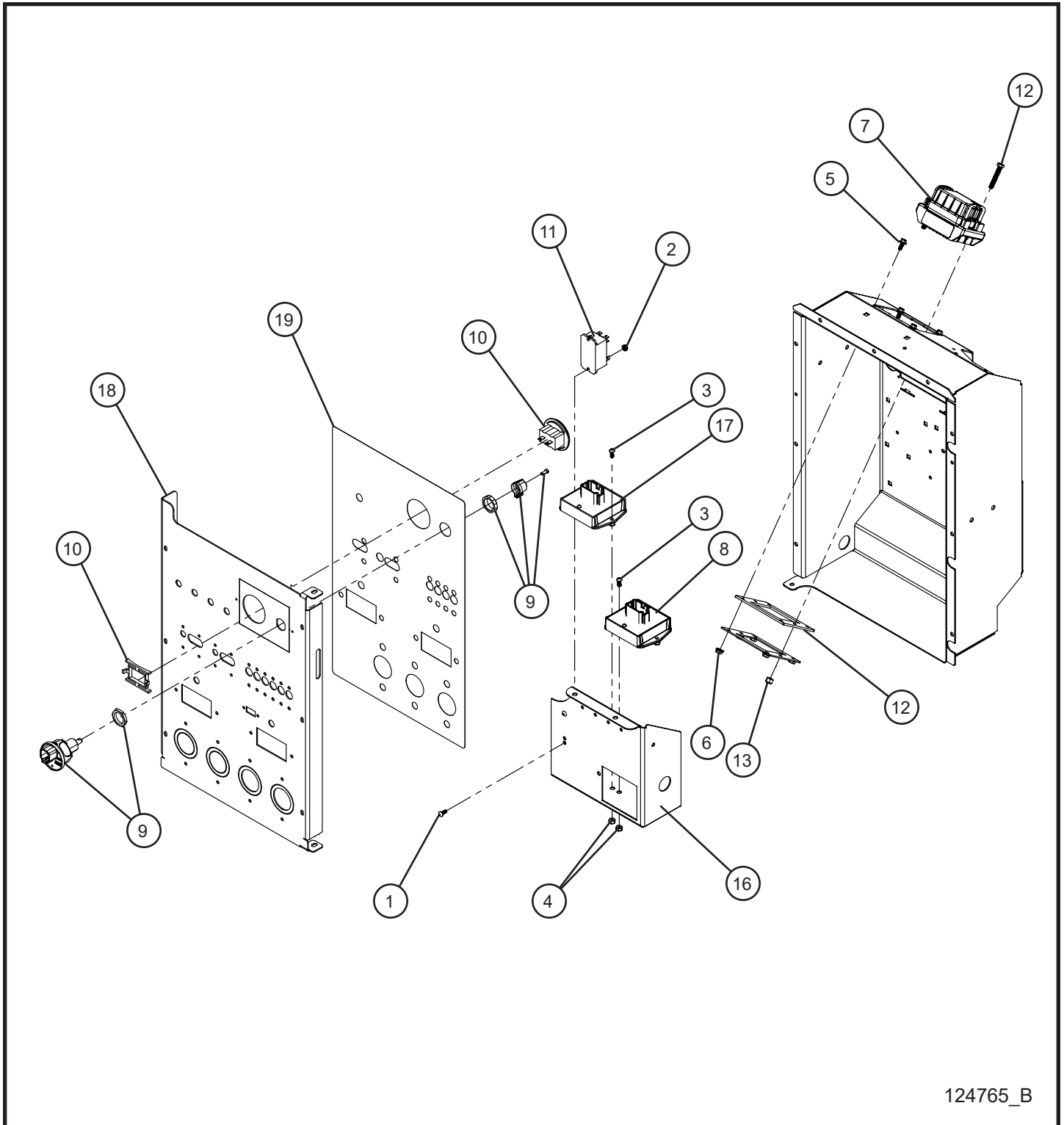

124765_B

7.1 - SLS Key Start Chief Fuse Box Assembly Group

Item	Part No.	Part Description	Qty.
1	041012	#8-32 x 1/2 MACHINE SCREW	2
2	044003	#8-32 KEPS NUT	2
3	041021	#10-24 x 1/2 PH-ROUND HEAD MACHINE SCREW	4
4	044019	#10-24 NYLOCK HEX NUT	4
5	056022	#10-24 X 1/2 SERRATED FLANGE HEX SCREW	4
6	057004	#10-24 SERRATED FLANGE HEX NUT	4
7	125014	HARNESS SLS CONTROL PANEL CHIEF PDM	1
8	108053	SLS 1.1 MODULE	1
9	106273	DEUTSCH CONNECT LEVER STYLE IGNITION SWITCH	1
10	340014	HOUR METER DIGITAL	1
11	105219	RELAY 30 AMP	1
12	123238	FOAM GASKET PDM BOX ADAPTER PLATE	1
13	123301	M6 x 1 x 40mm HEX HEAD BOLT	2
14	040013	M6 NYLOCK HEX NUT	2
15	124307P	ADAPTER PLATE CHIEF PDM BOX	1
16	111227P	MAXI-LITE COMPONENT BOX DIVIDER PANEL	1
17	105856	LOW FUEL MODULE WITH 5V POWER SUPPLY	1
18	126261P	OUTLET PANEL COMPONENT BOX KEY SWITCH/DEEP SEA ML	1
19	123894	DECAL OUTLET PANEL TOGGLE SWITCH MAXI LITE	1
NS	123283	DECAL BILINGUAL DO NOT REMOVE	2
NS	111211	FUSE HOLDER INLINE BLADE	1
NS	104990	2 AMP ATO/ATC BLADE FUSE	1
NS	105900	LOW FUEL LEVEL MODULE HARNESS	1
NS	105901	LOW FUEL MODULE WIRE SCHEMATIC	1
NS	124717	SCHEMATIC ENGINE RUN SLS RELAY PRO & MAXI-LITE	1
NS	124704	WIRE SCHEMATIC SLS HARNESS AND CHIEF PDM	1

7.2 - SLS Harness Chief PDM Fuse Box

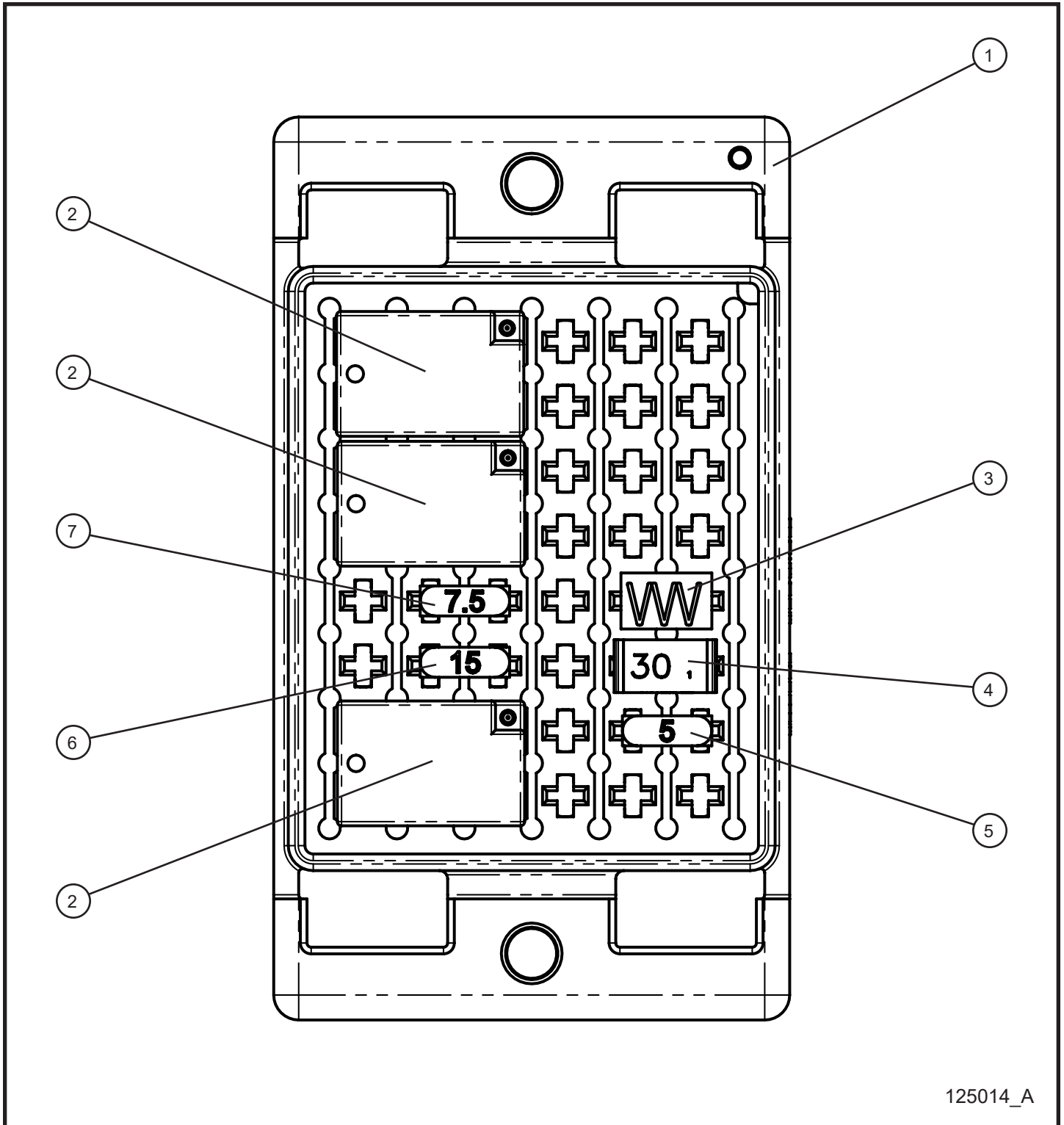

125014_A

7.2 - SLS Harness Chief PDM Fuse Box

Item	Part No.	Part Description	Qty.
--	125014	HARNESS SLS CONTROL PANEL CHIEF PDM COMPLETE	1
1	123116	CHIEF POWER DISTRIBUTION MODULE BASE	1
2	123133	35 AMP SPST RELAY	2
3	105204	RESISTOR 68OHM	1
4	105832	CIRCUIT BREAKER 30A	1
5	105843	5A MINI FUSE	1
6	105844	15A MINI FUSE	1
7	105876	7.5A MINI FUSE	1
NS	713002A	DIODE, 6A, 400V, P600G	5
NS	123115	CHIEF POWER DISTRIBUTION MODULE COVER	1

7.3 - DSE L401 MK II Control Box Assembly Group

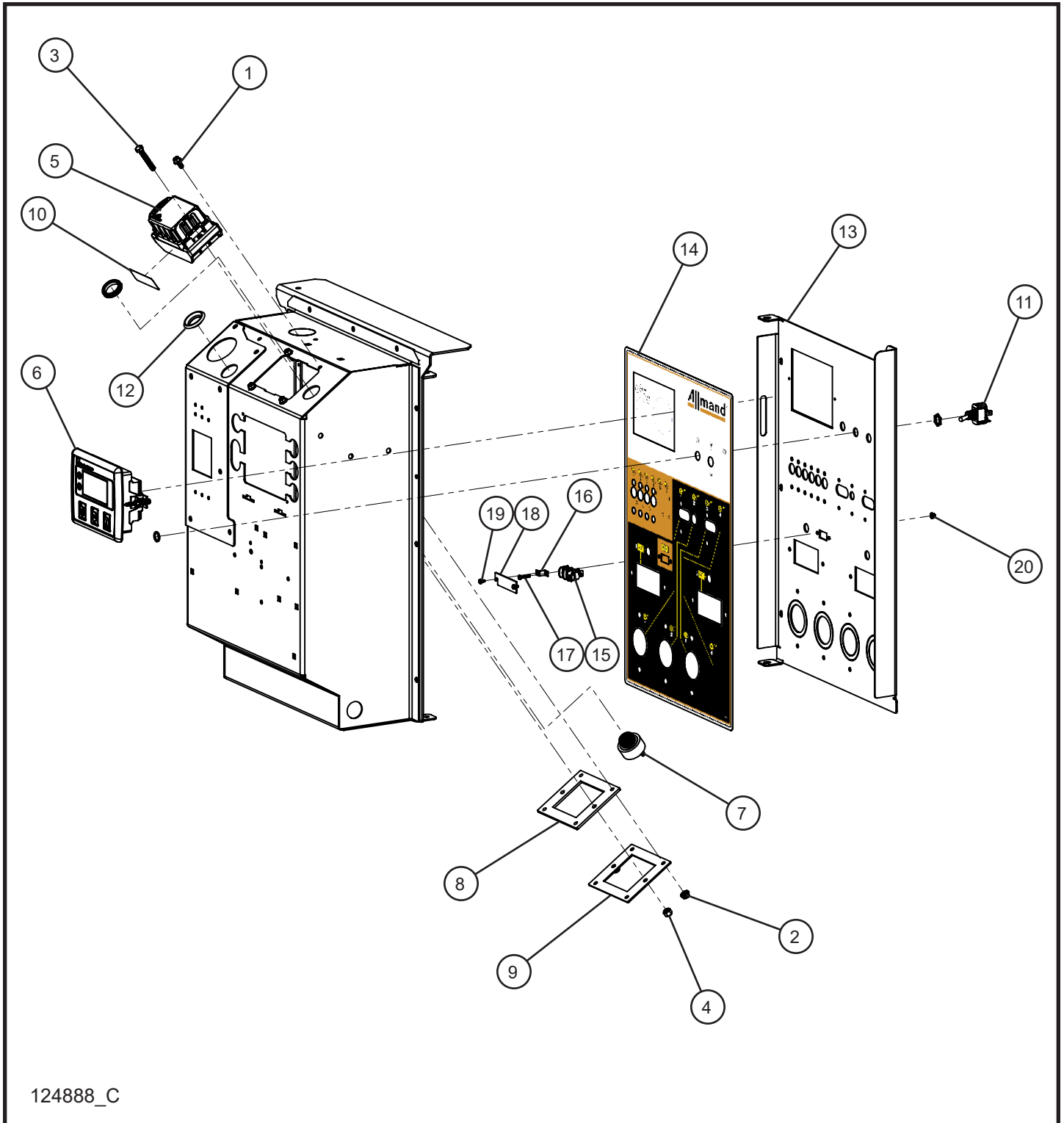

124888_C

7.3 - DSE L401 MK II Control Box Assembly Group

Item	Part No.	Part Description	Qty.
1	056022	#10-24 x 1/2 SERRATED FLANGE HEX SCREW	4
2	057004	#10-24 SERRATED FLANGE HEX NUT	4
3	123301	M6 x 1 x 40mm HEX HEAD BOLT	2
4	040013	M6 NYLOCK HEX NUT	2
5	123127	HARNESS DEEP SEA CONTROL PANEL	1
6	110154	DSE L401 MK II CONTROL MODULE	1
7	118086	AUDIBLE ALARM PANEL MOUNT	1
8	123238	FOAM GASKET PDM BOX ADAPTER PLATE	1
9	124307P	ADAPTER PLATE CHIEF PDM BOX	1
10	123283	DECAL BILINGUAL DO NOT REMOVE	2
11	123157	TOGGLE SWITCH SPST ON-OFF	1
12	064025	1 1/16 IN. PLASTIC PLUG	1
13	126261P	OUTLET PANEL COMPONENT BOX KEY SWITCH/DEEP SEA ML	1
14	123894	DECAL OUTLET PANEL TOGGLE SWITCH MAXI LITE	1
15	123900	2 POSITION TERMINAL STRIP	1
16	121845	BRACKET TERMINAL STRIP COVER	2
17	121849	M3 x 16 PH-PAN HEAD MACHINE SCREW	2
18	123899	COVER CLEAR 2 POSITION TERMINAL STRIP	1
19	041018	#6-32 x 1/4 PH-ROUND HEAD MACHINE SCREW	2
20	123932	M3 x 0.5 FLANGE NUT	2
NS	103864	FUSE HOLDER INLINE BLADE	1
NS	104990	FUSE BLADE 2 AMP ATO/ATC	1
NS	117572	SCHEMATIC DEEP SEA L401 NLV, PROII, ML HARNESS	1

7.4 - DSE L401 MK II Fuse Box

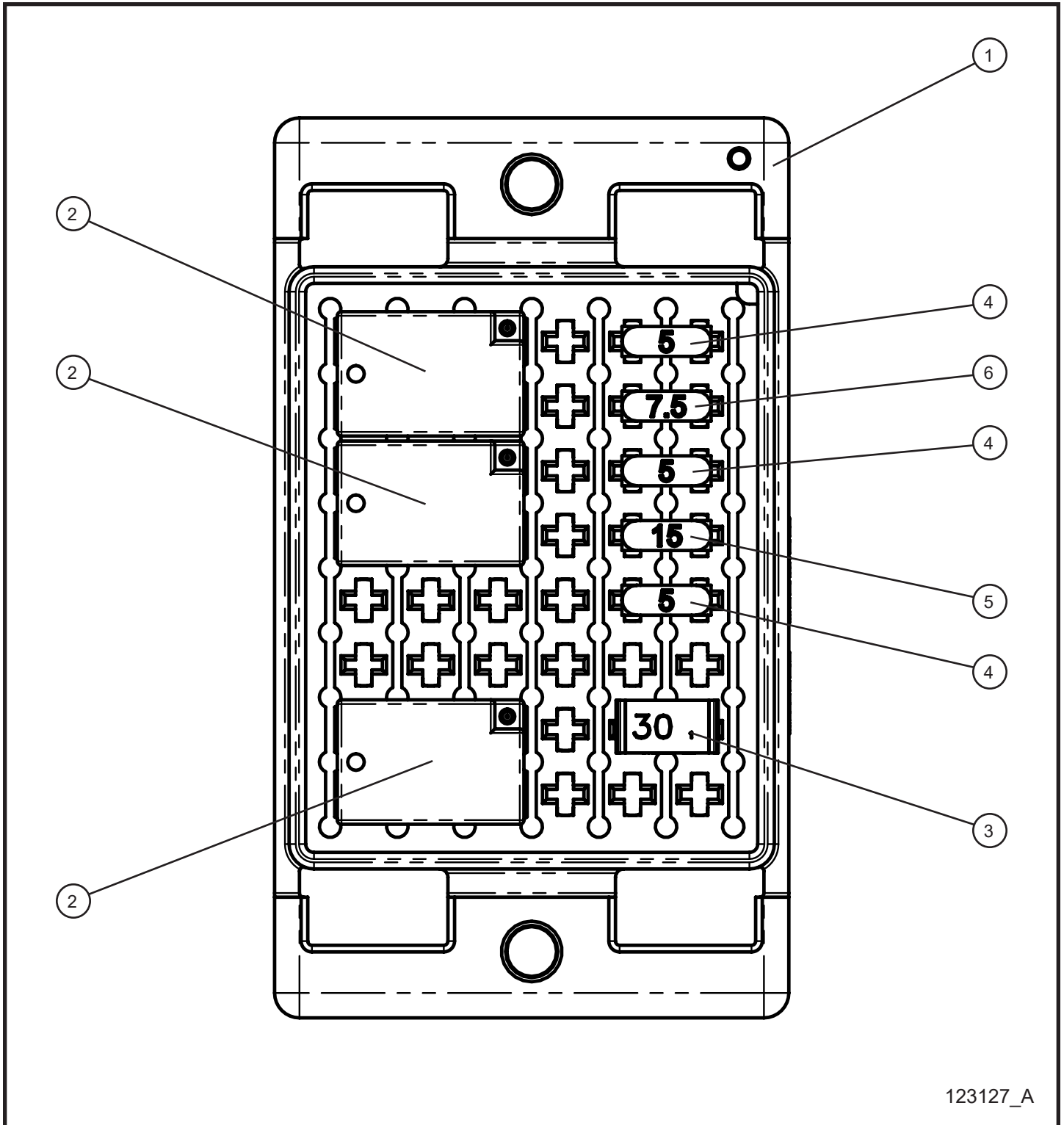

123127_A

7.4 - DSE L401 MK II Fuse Box

Item	Part No.	Part Description	Qty.
--	123127	HARNESS DEEP SEA CONTROL PANEL	1
1	123116	POWER DISTRIBUTION MODULE BASE	1
2	105201	35 AMP SPST RELAY	3
3	105832	CIRCUIT BREAKER 30A	1
4	105843	5A MINI FUSE	3
5	105844	15A MINI FUSE	1
6	105876	7.5A MINI FUSE	1
NS	101285	3W 68 OHM RESISTOR	1
NS	713002A	DIODE, 6A, 400V, P600G	5
NS	123115	CHIEF POWER DISTRIBUTION MODULE COVER	1

7.5 - Isuzu DSE L401 MK II Control Box Assembly Group

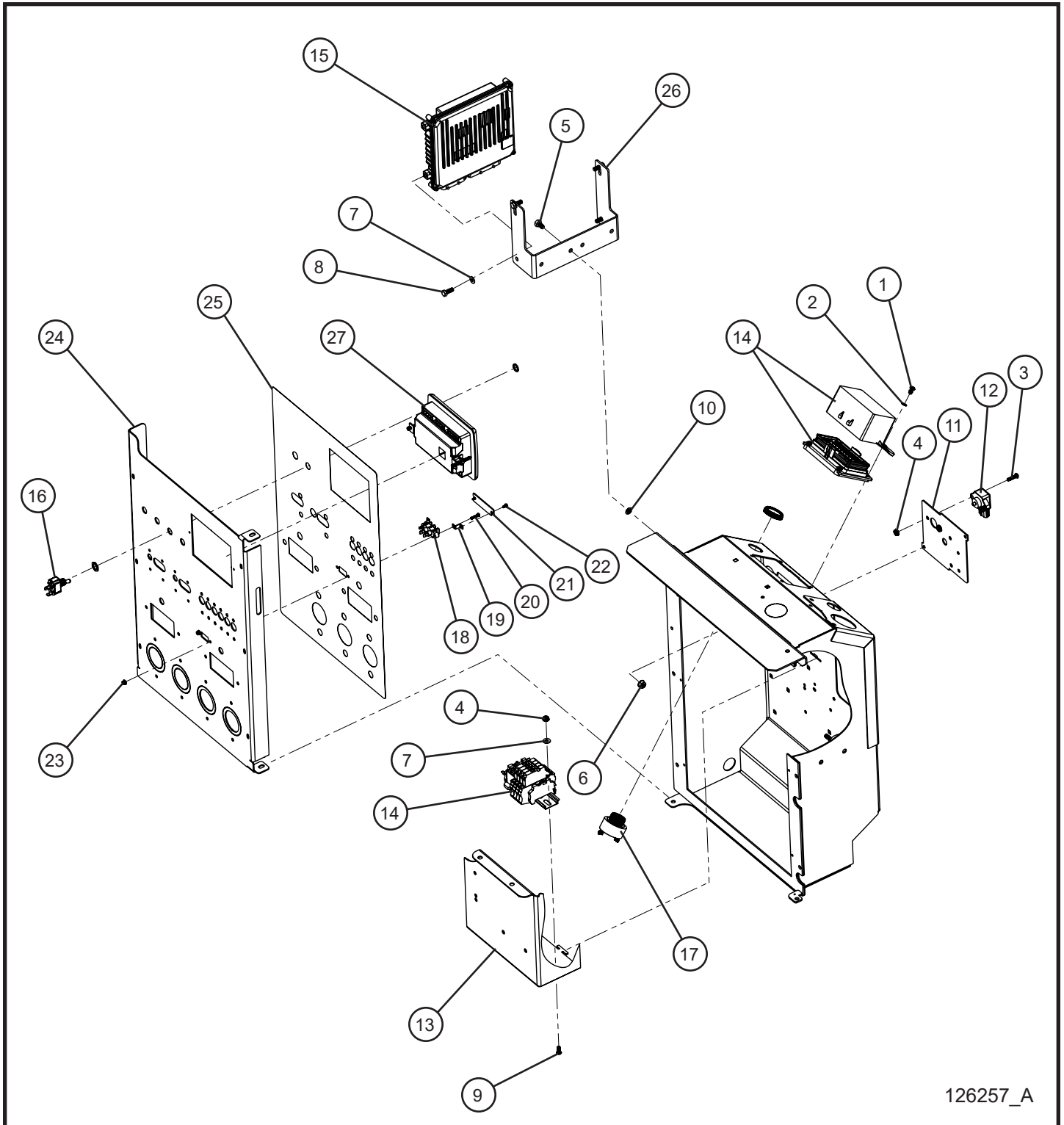

126257_A

7.5 - Isuzu DSE L401 MK II Control Box Assembly Group

Item	Part No.	Part Description	Qty.
1	041019	#10-32 x 3/8 PH-ROUND HEAD MACHINE SCREW	4
2	043017	#10 TOOTH LOCK WASHER	1
3	041027	#10-24 x 3/4 PH-ROUND HEAD MACHINE SCREW	2
4	044016	#10-24 KEPS HEX NUT	4
5	046005	1/4-20 x 1/2 HEX HEAD BOLT	2
6	044021	1/4-20 KEPS HEX NUT	4
7	047070	#10 FLAT WASHER	6
8	042019	M6 x 1mm x 16mm HEX HEAD BOLT	4
9	041021	#10-24 x 1/2 PH-ROUND HEAD MACHINE SCREW	2
10	101701	1/4 PUSH NUT	2
11	111228P	MAXI-LITE COMPONENT BOX BACK COVER	1
12	N/A	BAROMETRIC PRESSURE SENSOR	1
13	111227P	MAXI-LITE COMPONENT BOX DIVIDER PANEL	1
14	116064	HARNESS ISUZU 4LE2T T4F DSE L401 MK II	1
15	N/A	ENGINE CONTROL MODULE (ECM)	1
16	123157	TOGGLE SWITCH SPST ON-OFF	1
17	118086	AUDIBLE ALARM PANEL MOUNT	1
18	123900	2 POSITION TERMINAL STRIP	1
19	121845	BRACKET TERMINAL STRIP COVER	2
20	121849	M3 x 16 PH-PAN HEAD MACHINE SCREW	2
21	123899	COVER CLEAR 2 POSITION TERMINAL STRIP	1
22	041018	#6-32 x 1/4 PH-ROUND HEAD MACHINE SCREW	2
23	123932	M3 x 0.5 FLANGE NUT	2
24	126261P	OUTLET PANEL COMPONENT BOX KEY SWITCH/DEEP SEA ML	1
25	123894	DECAL OUTLET PANEL TOGGLE SWITCH MAXI LITE	1
26	112555P	ISUZU 4LE2T ECM BRACKET	1
27	110154	DSE L401 MK II CONTROL MODULE	1
NS	126035	SCHEMATIC REMOTE START DEEP SEA L401	1
NS	103864	FUSE HOLDER INLINE BLADE	1
NS	104990	FUSE BLADE 2 AMP ATO/ATC	1
NS	116064	ISUZU 4LE2T HARNESS DSE L401 MK II	1

7.6 - Isuzu DSE L401 MK II Harness Fuse Box

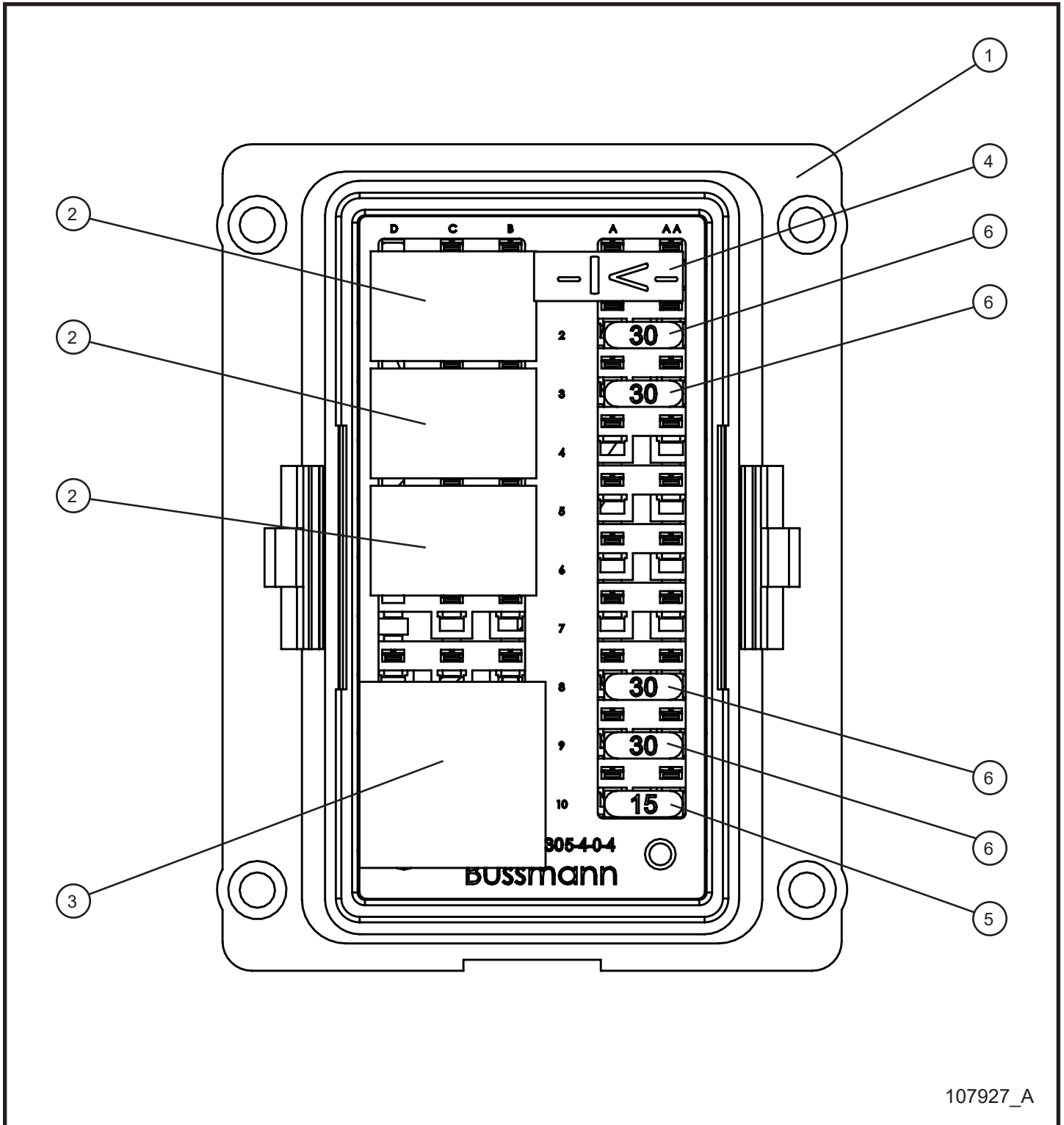

107927_A

7.6 - Isuzu DSE L401 MK II Harness Fuse Box

Item	Part No.	Part Description	Qty.
--	116064	HARNESS ISUZU 4LE2T T4F DSE L401 MK II	1
1	107913	BUSSMANN 50 PIN BOARD MODULE	1
2	107928	35 AMP SPST RELAY	3
3	105202	50 AMP SPST RELAY	1
4	105203	BLOCKING DIODE KEYED	1
5	105844	15A MINI FUSE	1
6	107929	30A MINI FUSE	4

7.7 - Isuzu DSE L401 MK II Relay and Terminal Blocks

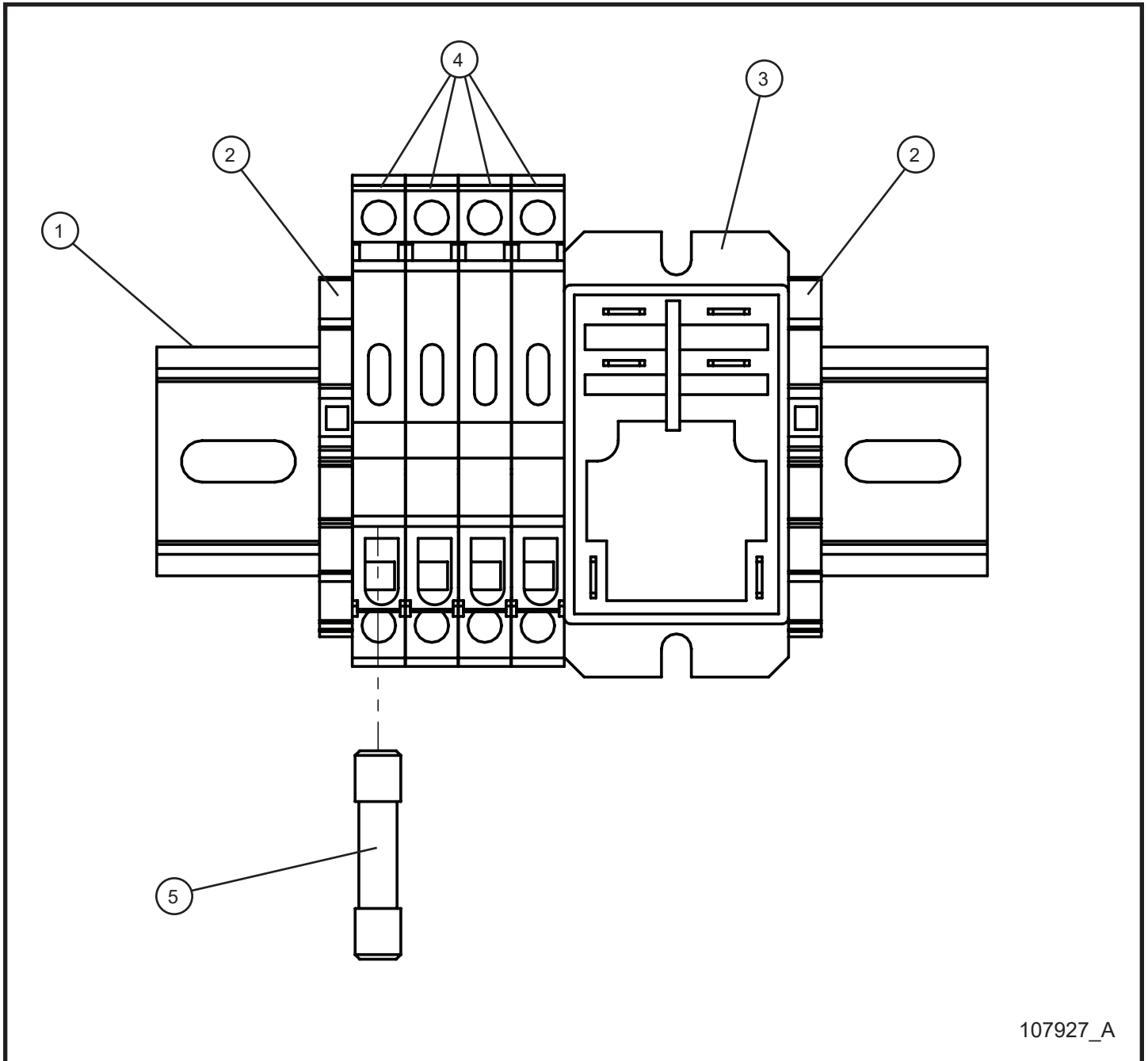

7.7 - Isuzu DSE L401 MK II Relay and Terminal Blocks

Item	Part No.	Part Description	Qty.
--	116064	HARNESSES ISUZU 4LE2T T4F DSE L401 MK II	1
1	105775	5" 35mm DIN RAIL	1
2	107377	24-10 AWG END STOP	2
3	106864	30 AMP DC POWER RELAY	1
4	107540	24-10 AWG FUSE TERMINAL BLOCK	4
5	108459	2 AMP GMA FUSE	4

7.8 - DSE L401 MK II Remote Start Terminals

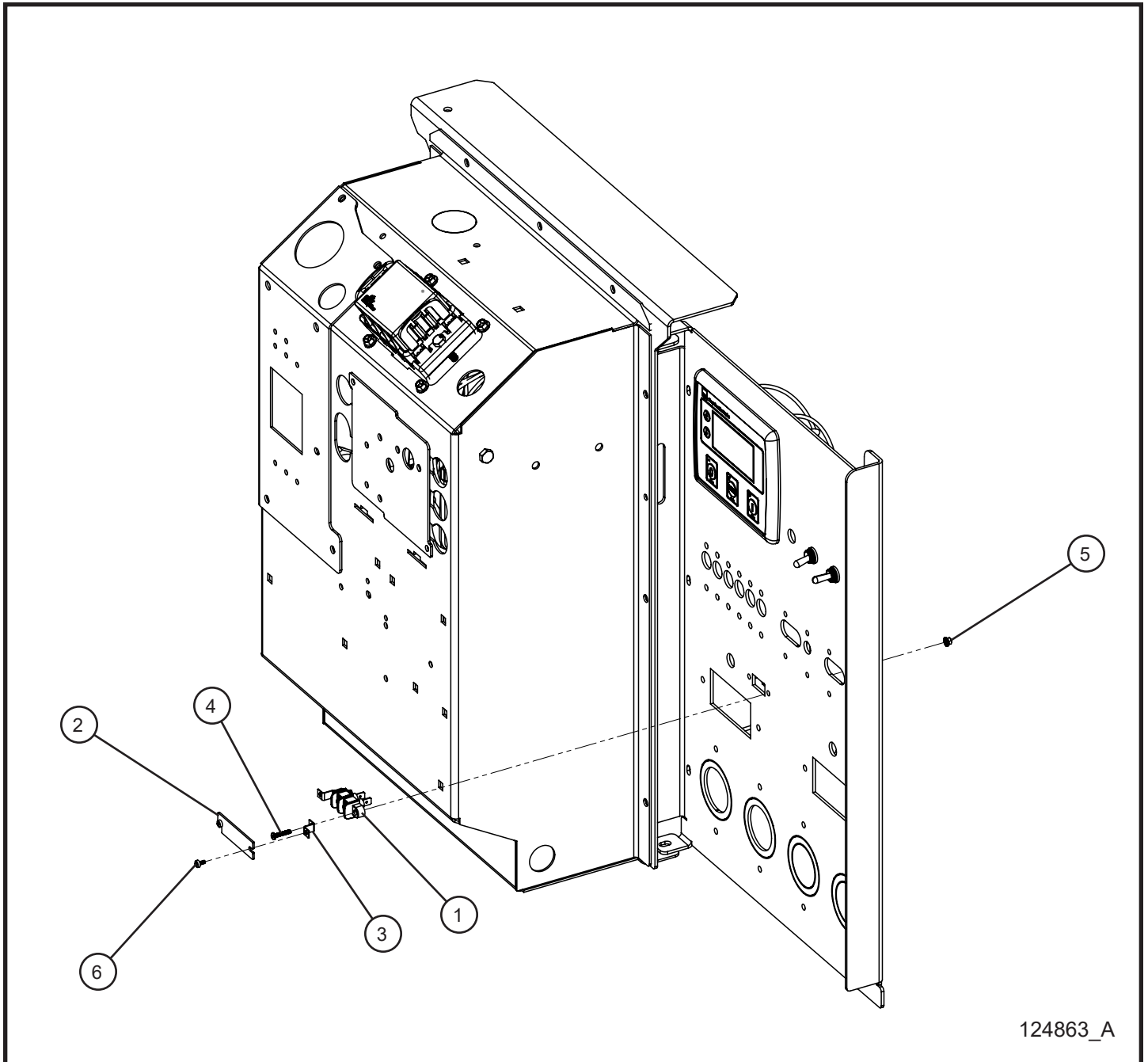

7.8 - DSE L401 MK II Remote Start Terminals

Item	Part No.	Part Description	Qty.
1	123900	2 POSITION TERMINAL STRIP	1
2	123899	COVER CLEAR 2 POSITION TERMINAL STRIP	1
3	121845	BRACKET TERMINAL STRIP COVER	2
4	121849	M3 x 16 PH-PAN HEAD MS	2
5	123932	M3 x 0.5mm FLANGE NUT	2
6	041018	#6-32 x 1/4 PH-ROUND HEAD MS	2
NS	126032	WIRE REMOTE START TO CONTROLLER	1
NS	126034	WIRE REMOTE START TO GROUND	1
NS	126035	SCHEMATIC REMOTE START DEEP SEA L401	1

7.9 - 8kW 1PH 2-30A Twistlock 1-30A RV Outlet Package I

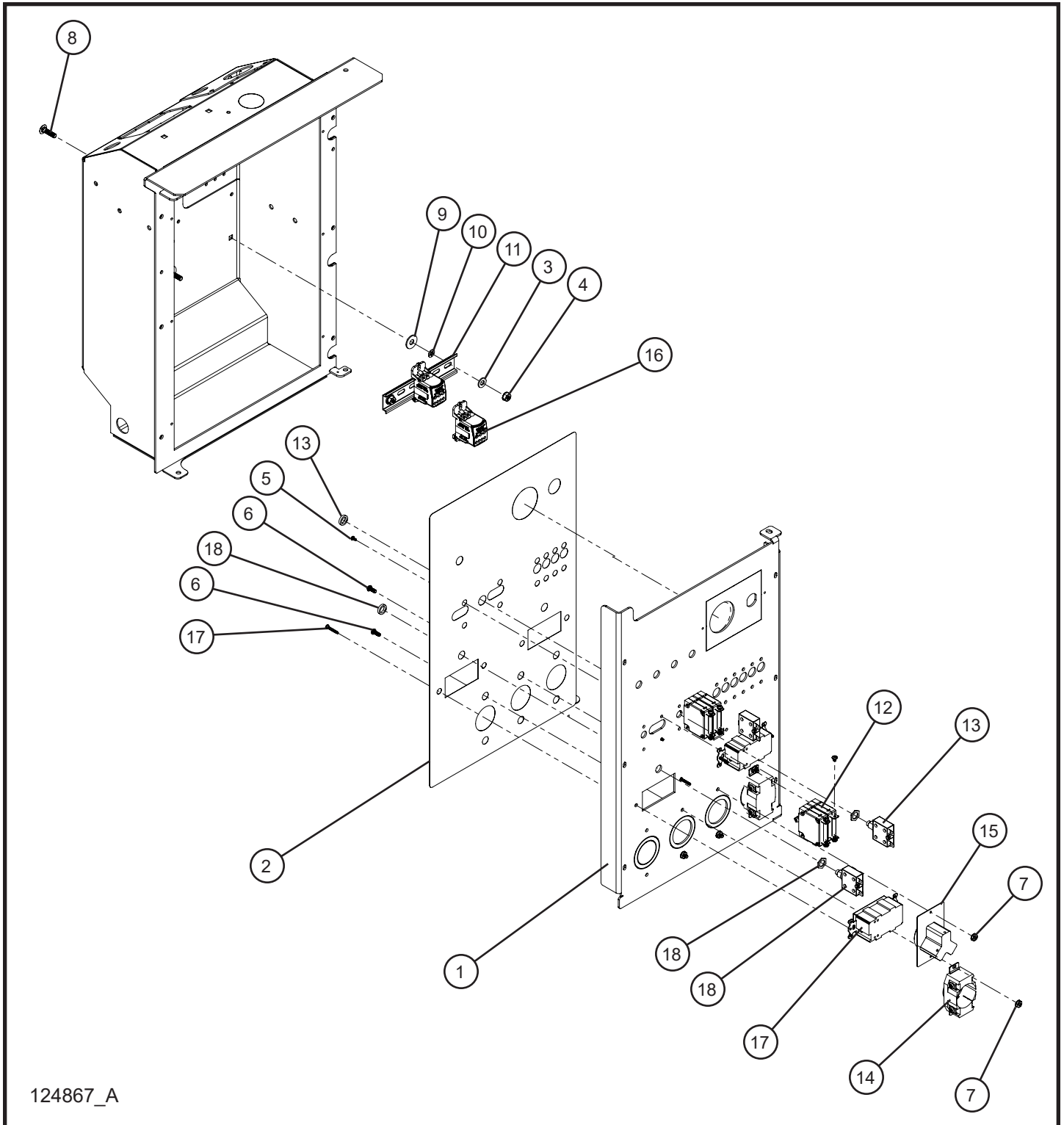

124867_A

7.9 - 8kW 1PH 2-30A Twistlock 1-30A RV Outlet Package I

Item	Part No.	Part Description	Qty.
1	124862P	OUTLET PANEL COMPONENT BOX KEY SWITCH/DEEP SEA ML	1
2	123894	DECAL OUTLET PANEL TOGGLE SWITCH MAXI LITE	1
3	047005	1/4 FLAT WASHER	2
4	044021	1/4-20 KEPS HEX NUT	2
5	041252	M3 - 0.05MM X 6MM MACHINE SCREW	4
6	041021	#10-24 x 1/2 PH-ROUND HEAD MACHINE SCREW	6
7	044016	#10-24 KEPS HEX NUT	6
8	100342	1/4-20 x 1 CARRIAGE BOLT	2
9	047010	5/16 FLAT WASHER	2
10	101701	1/4 PUSH NUT	2
11	114488	DIN RAIL 6 INCH	1
12	123260	30AMP DOUBLE POLE CIRCUIT BREAKER	2
13	118662	BREAKER THERMAL PUSH BUTTON 30A 250VAC	1
14	653102	30A 125-250V TWISTLOCK RECEPTACLE	2
15	680815	30A 125V RV OUTLET	1
16	104779	ERIFLEX DISTRIBUTION BLOCK	2
17	330499	20A GFCI RECEPTACLE	2
18	118398	BREAKER THERMAL PUSH BUTTON 20A CSA	2
NS	124482	SCHEMATIC OUTLET PANEL 8KW 1-PHASE MAXI II	1

7.10 - 8kW 1PH 2-30A Twistlock 1-30A RV Outlet Package II

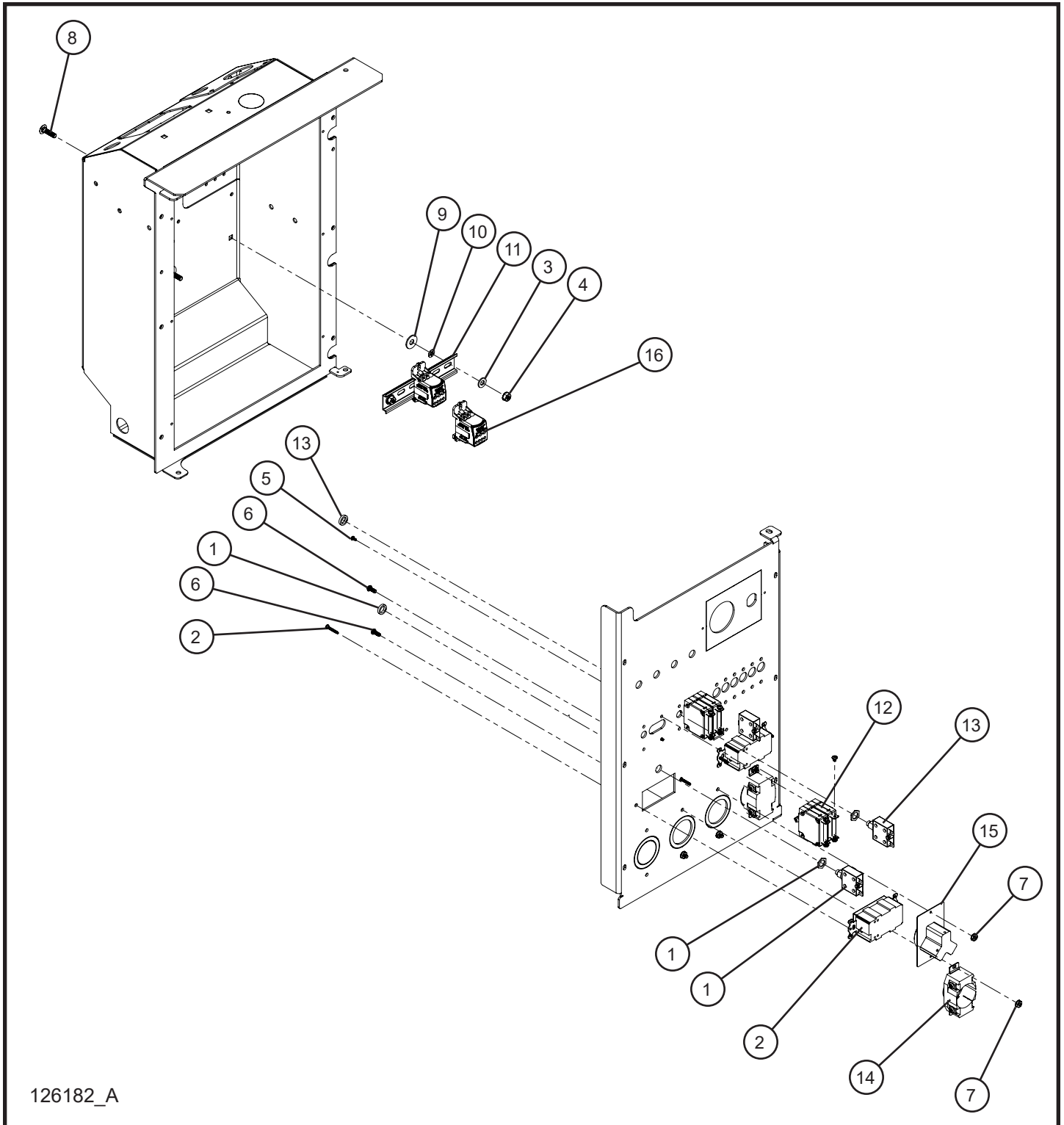

126182_A

7.10 - 8kW 1PH 2-30A Twistlock 1-30A RV Outlet Package II

Item	Part No.	Part Description	Qty.
1	118398	BREAKER THERMAL PUSH BUTTON 20A CSA	2
2	330499	20A GFCI RECEPTACLE	2
3	047005	1/4 FLAT WASHER	2
4	044021	1/4-20 KEPS HEX NUT	2
5	041252	M3 - 0.05MM X 6MM MACHINE SCREW	4
6	041021	#10-24 x 1/2 PH-ROUND HEAD MACHINE SCREW	6
7	044016	#10-24 KEPS HEX NUT	6
8	100342	1/4-20 x 1 CARRIAGE BOLT	2
9	047010	5/16 FLAT WASHER	2
10	101701	1/4 PUSH NUT	2
11	114488	DIN RAIL 6 INCH	1
12	123260	30AMP DOUBLE POLE CIRCUIT BREAKER	2
13	118662	BREAKER THERMAL PUSH BUTTON 30A 250VAC	1
14	653102	30A 125-250V TWISTLOCK RECEPTACLE	2
15	680815	30A 125V RV OUTLET	1
16	104779	ERIFLEX DISTRIBUTION BLOCK	2
NS	114862	HARNESS DOUBLE GFCI MAXI II	1
NS	123268	HARNESS BREAKER TO OUTLET MAXI II	1
NS	123269	HARNESS BREAKER TO DB MAXI II	1
NS	115104	HARNESS OUTLET GROUNDS MAXI II	1
NS	115105	HARNESS OUTLET COMM MAXI II	1
NS	124482	SCHEMATIC OUTLET PANEL 8KW 1-PHASE MAXI II	1

7.11 - 15/20kW 1PH 2-30A Twistlock 2-50A CS6369 Outlet Package

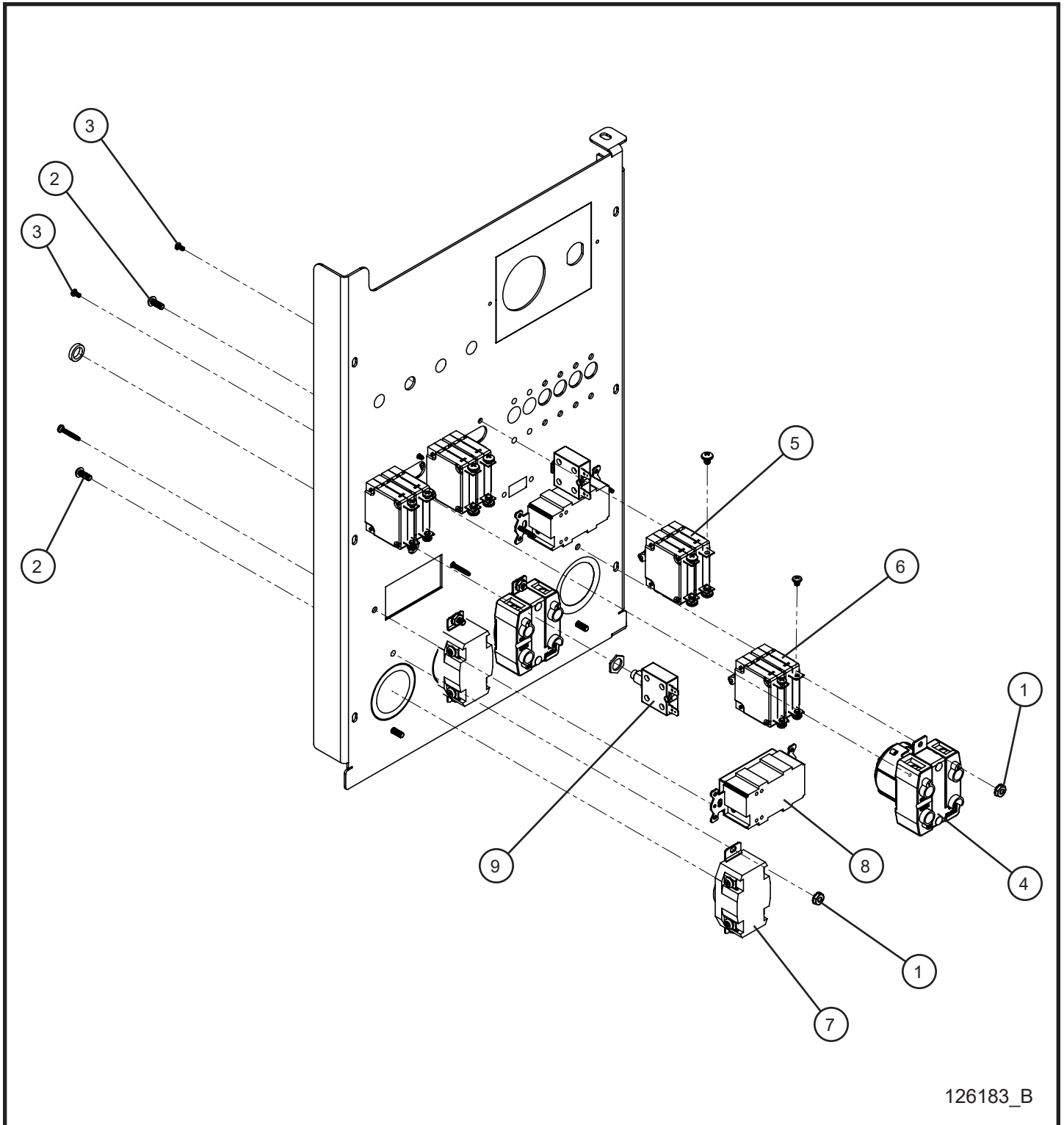

126183_B

7.11 - 15/20kW 1PH 2-30A Twistlock 2-50A CS6369 Outlet Package

Item	Part No.	Part Description	Qty.
1	044016	#10-24 KEPS HEX NUT	8
2	041021	#10-24 X 1/2 PH-ROUND HEAD MACHINE SCREW	8
3	041252	M3 - 0.05mm x 6mm MACHINE SCREW	8
4	125220	50AMP 125/250 VAC CS6369 RECPTACLE LEVITON	2
5	123261	50AMP DOUBLE POLE CIRCUIT BREAKER	2
6	123260	30AMP DOUBLE POLE CIRCUIT BREAKER	2
7	653102	30A 125-250V TWISTLOCK RECEPTACLE	2
8	330499	RECEPTACLE GFCI 20 AMP	2
9	118398	BREAKER THERMAL PUSH BUTTON 20A CSA	2
NS	114862	HARNESS DOUBLE GFCI MAXI II	1
NS	118321	HARNESS BREAKER TO OUTLET MAXI II	1
NS	118322	HARNESS BREAKER TO DB MAXI II	1
NS	118323	HARNESS OUTLET GROUNDS MAXI II	1
NS	118324	HARNESS OUTLET COMM MAXI II	1
NS	118325	SCHEMATIC OUTLET PANEL 2-30A & 2-50A TWISTLOCK MP15XR	1

7.12 - 15/20kW 1PH 2-30A TL 1-50A RV 1-30A RV Outlet Package

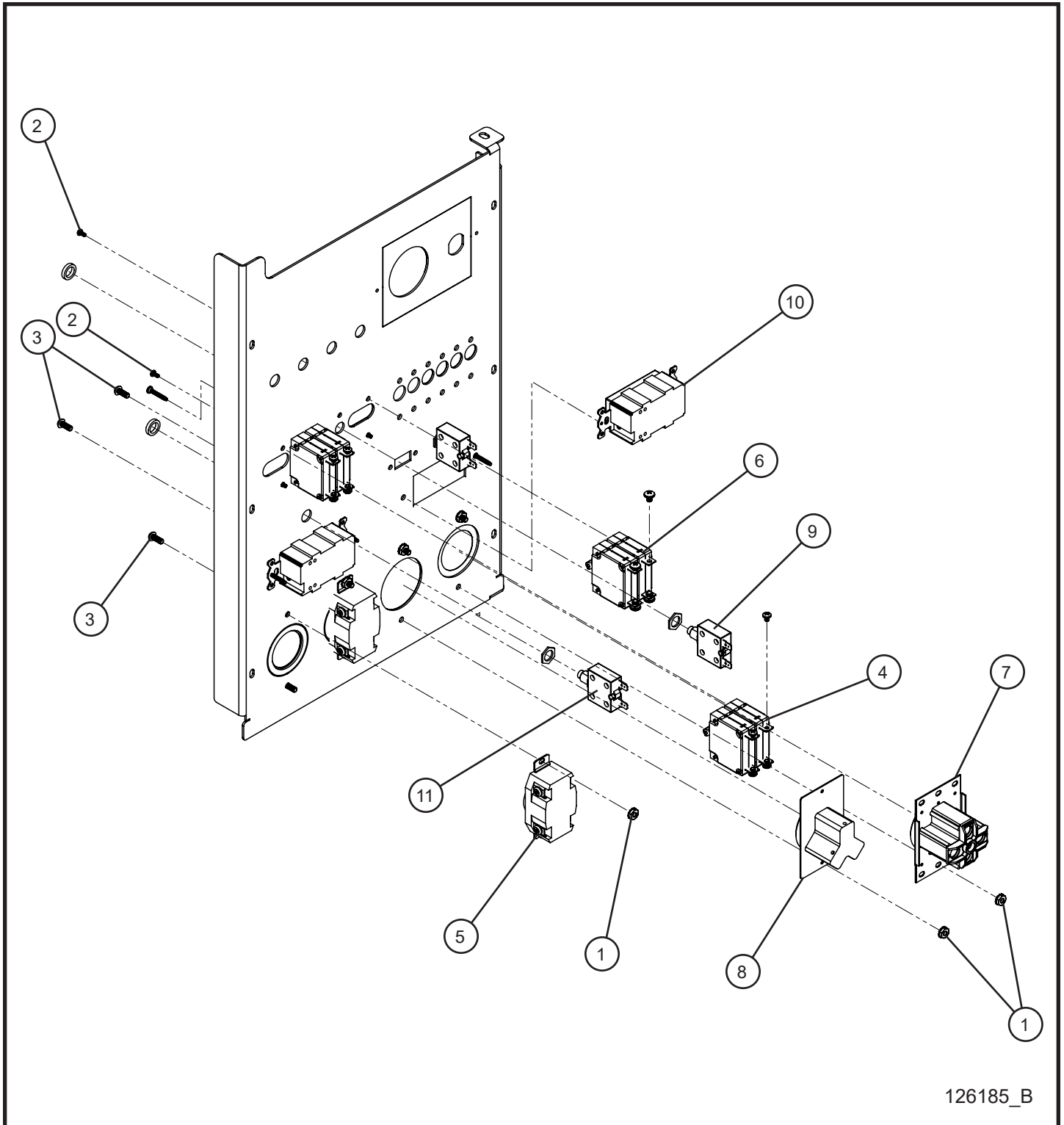

126185_B

7.12 - 15/20kW 1PH 2-30A TL 1-50A RV 1-30A RV Outlet Package

Item	Part No.	Part Description	Qty.
1	044016	#10-24 KEPS HEX NUT	8
2	041021	#10-24 X 1/2 PH-ROUND HEAD MACHINE SCREW	6
3	041252	M3 - 0.05mm x 6mm MACHINE SCREW	8
4	123260	30AMP DOUBLE POLE CIRCUIT BREAKER	2
5	653102	30A 125-250V TWISTLOCK RECEPTACLE	2
6	123261	50AMP DOUBLE POLE CIRCUIT BREAKER	1
7	022351	14-50R 50A/250V RV NEMA RECEPTACLE	1
8	680815	30A/125V RV OUTLET	1
9	118662	BREAKER THERMAL PUSH BUTTON 30A 250VAC	1
10	330499	RECEPTACLE GFCI 20 AMP	2
11	118398	BREAKER THERMAL PUSH BUTTON 20A CSA	2
NS	114862	HARNESS DOUBLE GFCI MAXI II	1
NS	123270	HARNESS BREAKER TO OUTLET MAXI II	1
NS	123271	HARNESS BREAKER TO DB MAXI II	1
NS	114879	HARNESS OUTLET GROUNDS MAXI II	1
NS	114880	HARNESS OUTLET COMM MAXI II	1
NS	124483	SCHEMATIC OUTLET PANEL 1-50A RV, 1-30A RV, 2-TL MPXR15	1

7.13 - 15/20kW 1PH 2-30A RV 2-50A RV Outlet Package

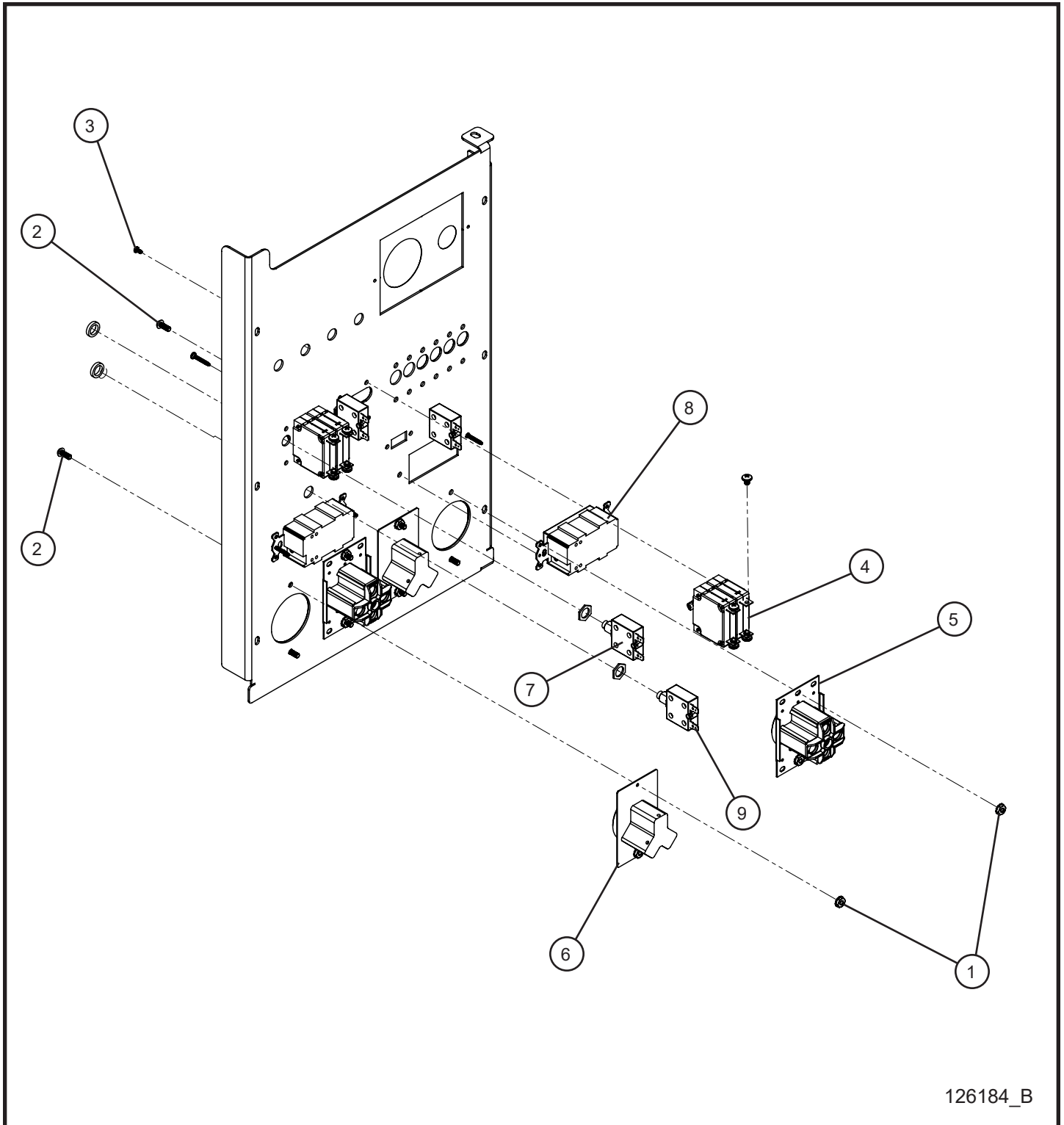

126184_B

7.13 - 15/20kW 1PH 2-30A RV 2-50A RV Outlet Package

Item	Part No.	Part Description	Qty.
1	044016	#10-24 KEPS HEX NUT	8
2	041021	#10-24 X 1/2 PH-ROUND HEAD MACHINE SCREW	8
3	041252	M3 - 0.05mm x 6mm MACHINE SCREW	4
4	123261	50AMP DOUBLE POLE CIRCUIT BREAKER	2
5	022351	14-50R 50A/250V RV NEMA RECEPTACLE	2
6	680815	30A/125V RV OUTLET	2
7	118662	BREAKER THERMAL PUSH BUTTON 30A 250VAC	2
8	330499	RECEPTACLE GFCI 20 AMP	2
9	118398	BREAKER THERMAL PUSH BUTTON 20A CSA	2
NS	114862	HARNESS DOUBLE GFCI MAXI II	1
NS	123272	HARNESS BREAKER TO OUTLET MAXI II	1
NS	123273	HARNESS BREAKER TO DB MAXI II	1
NS	116678	HARNESS OUTLET GROUNDS MAXI II	1
NS	116679	HARNESS OUTLET COMM MAXI II	1
NS	124484	SCHEMATIC OUTLET PANEL 2-50A RV, 2-30A RV, 2-GFCI MPXR15	1

7.14 - 20kW 3PH 4-30A Twistlock Outlet Package

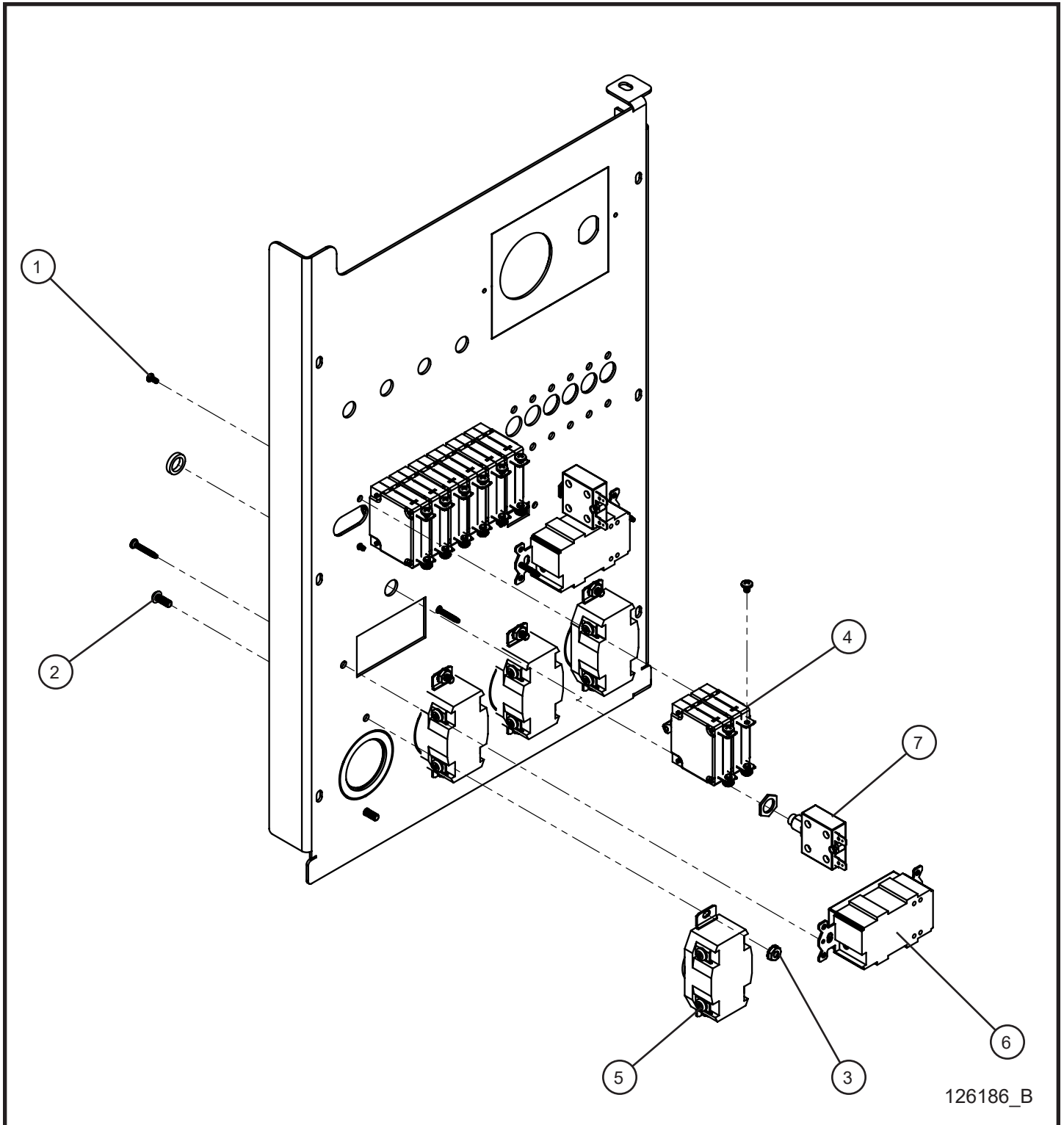

7.14 - 20kW 3PH 4-30A Twistlock Outlet Package

Item	Part No.	Part Description	Qty.
1	041252	M3 - 0.05mm x 6mm MACHINE SCREW	8
2	041021	#10-24 X 1/2 PH-ROUND HEAD MACHINE SCREW	8
3	044016	#10-24 KEPS HEX NUT	8
4	123260	30AMP DOUBLE POLE CIRCUIT BREAKER	4
5	653102	30A 125-250V TWISTLOCK RECEPTACLE	4
6	330499	RECEPTACLE GFCI 20 AMP	2
7	118398	BREAKER THERMAL PUSH BUTTON 20A CSA	2
NS	114862	HARNESS DOUBLE GFCI MAXI II	1
NS	114863	HARNESS BREAKER TO OUTLET MAXI II	1
NS	114864	HARNESS BREAKER TO DB MAXI II	1
NS	114865	HARNESS OUTLET GROUNDS MAXI II	1
NS	114866	HARNESS OUTLET COMM MAXI II	1
NS	114026	SCHEMATIC OUTLET PANEL 20 KW 3PHASE MAXI II	1

7.15 - 15/20kW 1PH 2-30A RV 1-50A RV 1-50A TL Outlet Package

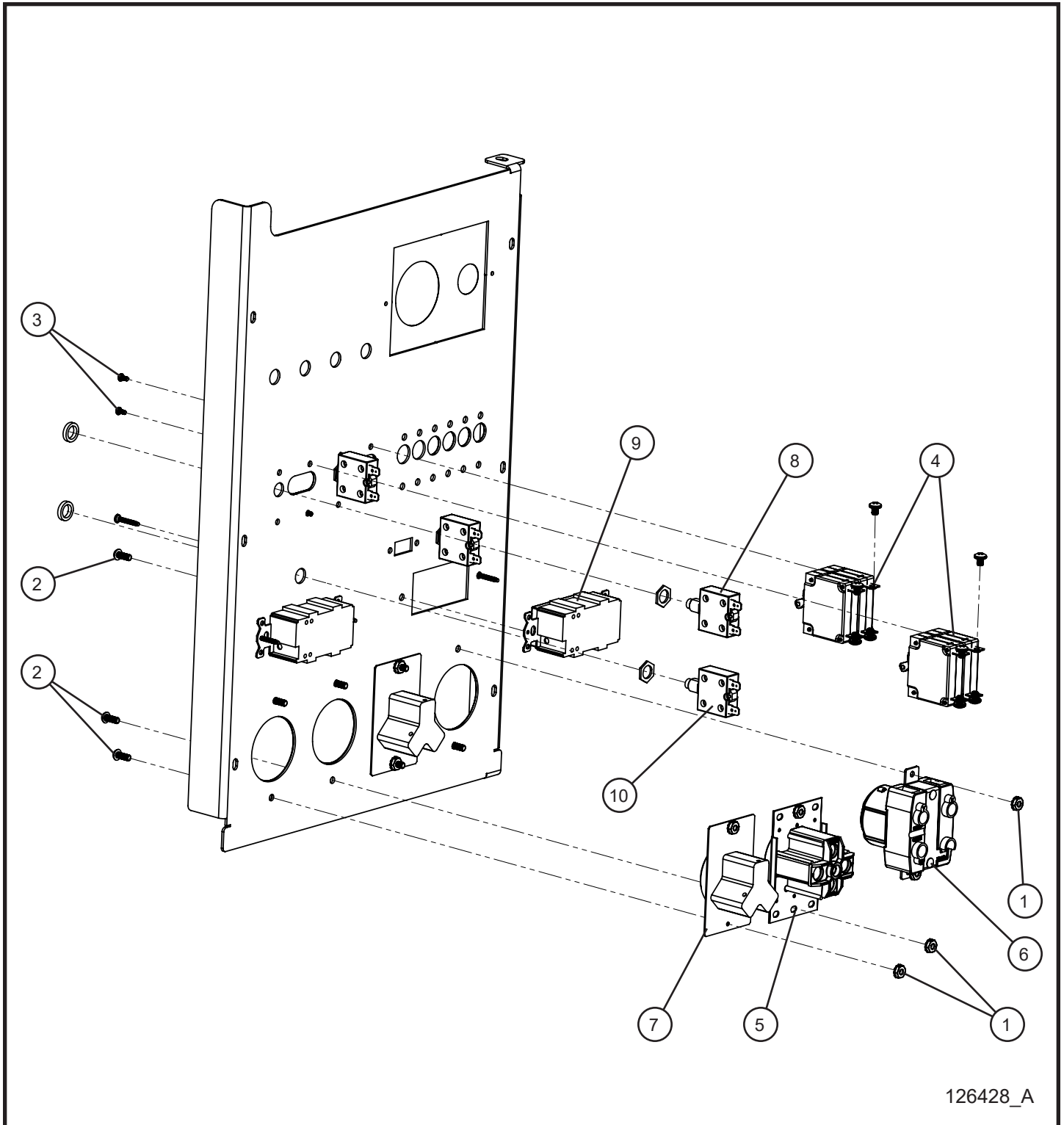

126428_A

7.15 - 15/20kW 1PH 2-30A RV 1-50A RV 1-50A TL Outlet Package

Item	Part No.	Part Description	Qty.
1	044016	#10-24 KEPS HEX NUT	8
2	041021	#10-24 X 1/2 PH-ROUND HEAD MACHINE SCREW	8
3	041252	M3 - 0.05mm x 6mm MACHINE SCREW	4
4	123261	50AMP DOUBLE POLE CIRCUIT BREAKER	2
5	022351	14-50R 50A/250V RV NEMA RECEPTACLE	1
6	125220	50AMP 125/250 VAC CS6369 RECPTACLE LEVITON	1
7	680815	30A/125V RV OUTLET	2
8	118662	BREAKER THERMAL PUSH BUTTON 30A 250VAC	2
9	330499	RECEPTACLE GFCI 20 AMP	2
10	118398	BREAKER THERMAL PUSH BUTTON 20A CSA	2
NS	114862	HARNESS DOUBLE GFCI MAXI II	1
NS	123272	HARNESS BREAKER TO OUTLET MAXI II	1
NS	123273	HARNESS BREAKER TO DB MAXI II	1
NS	116678	HARNESS OUTLET GROUNDS MAXI II	1
NS	116679	HARNESS OUTLET COMM MAXI II	1
NS	126439	SCHEMATIC OUTLET PANEL 2-30A RV, 1-50A RV, 1-50A TL MAXI	1

7.16 - Distribution Blocks

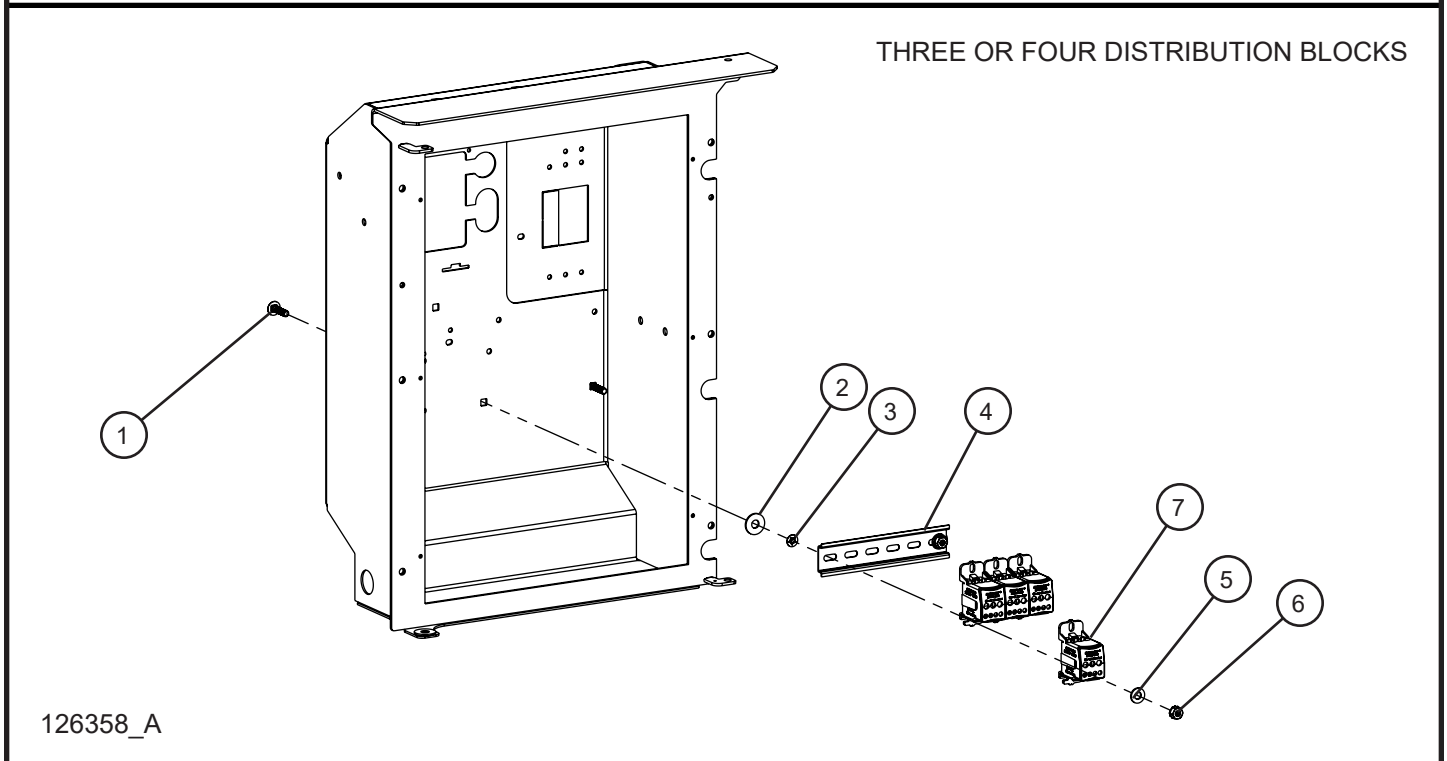
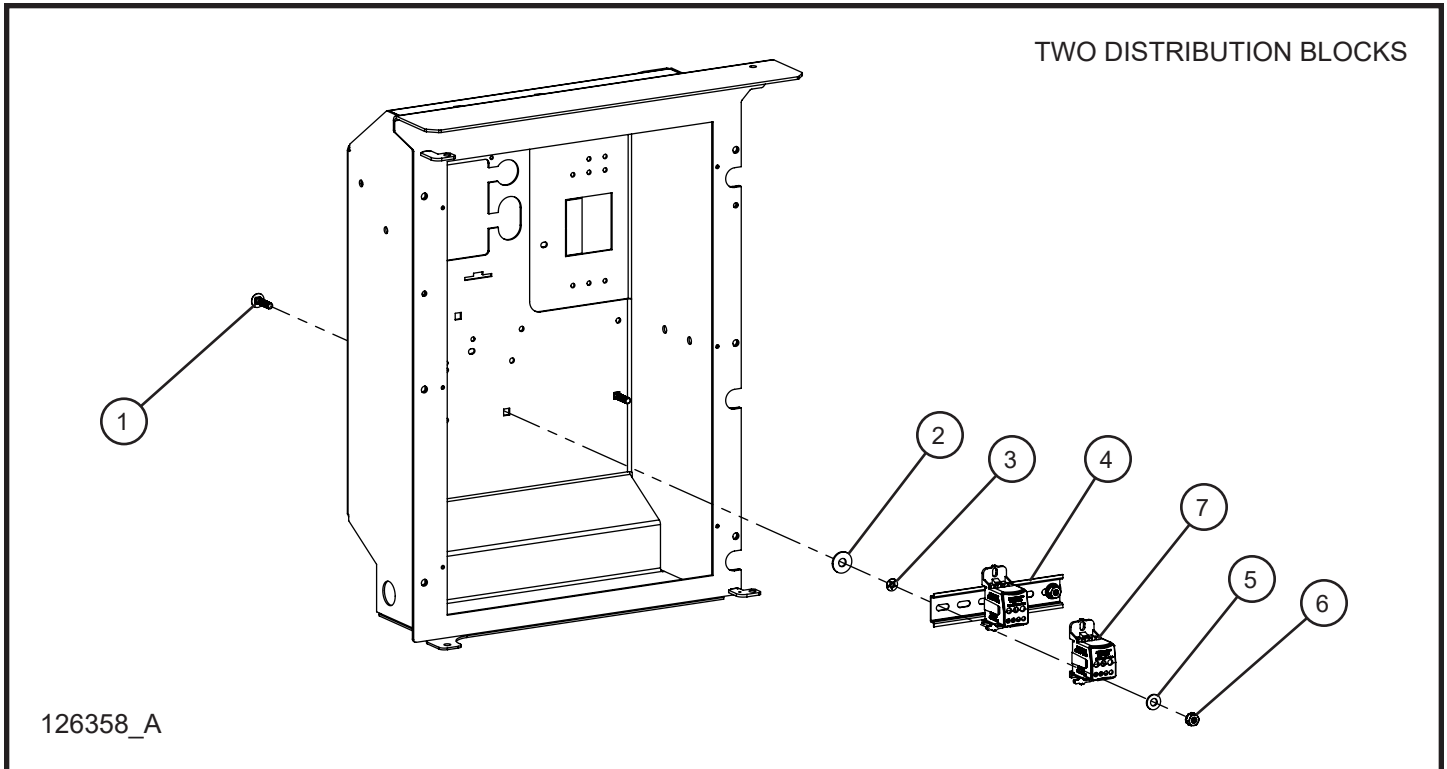

7.16 - Distribution Blocks

Item	Part No.	Part Description	Qty.
1	100342	1/4-20 x 1 CARRIAGE BOLT	2
2	047010	5/16 FLAT WASHER	2
3	101701	1/4 PUSH NUT	2
4	114488	DIN RAIL 6.00 INCH	1
5	047005	1/4 FLAT WASHER	2
6	044021	1/4-20 KEPS HEX NUT	2
7	104779	DISTRIBUTION BLOCK ERIFLEX	4
NS	114481	WIRE 4 AWG BLACK X 7.00	1
NS	114481	WIRE 4 AWG BLACK X 7.00	1
NS	114482	WIRE 4 AWG RED X 7.00	1

7.17 - Tower Toggle Switch and Interior Work Light

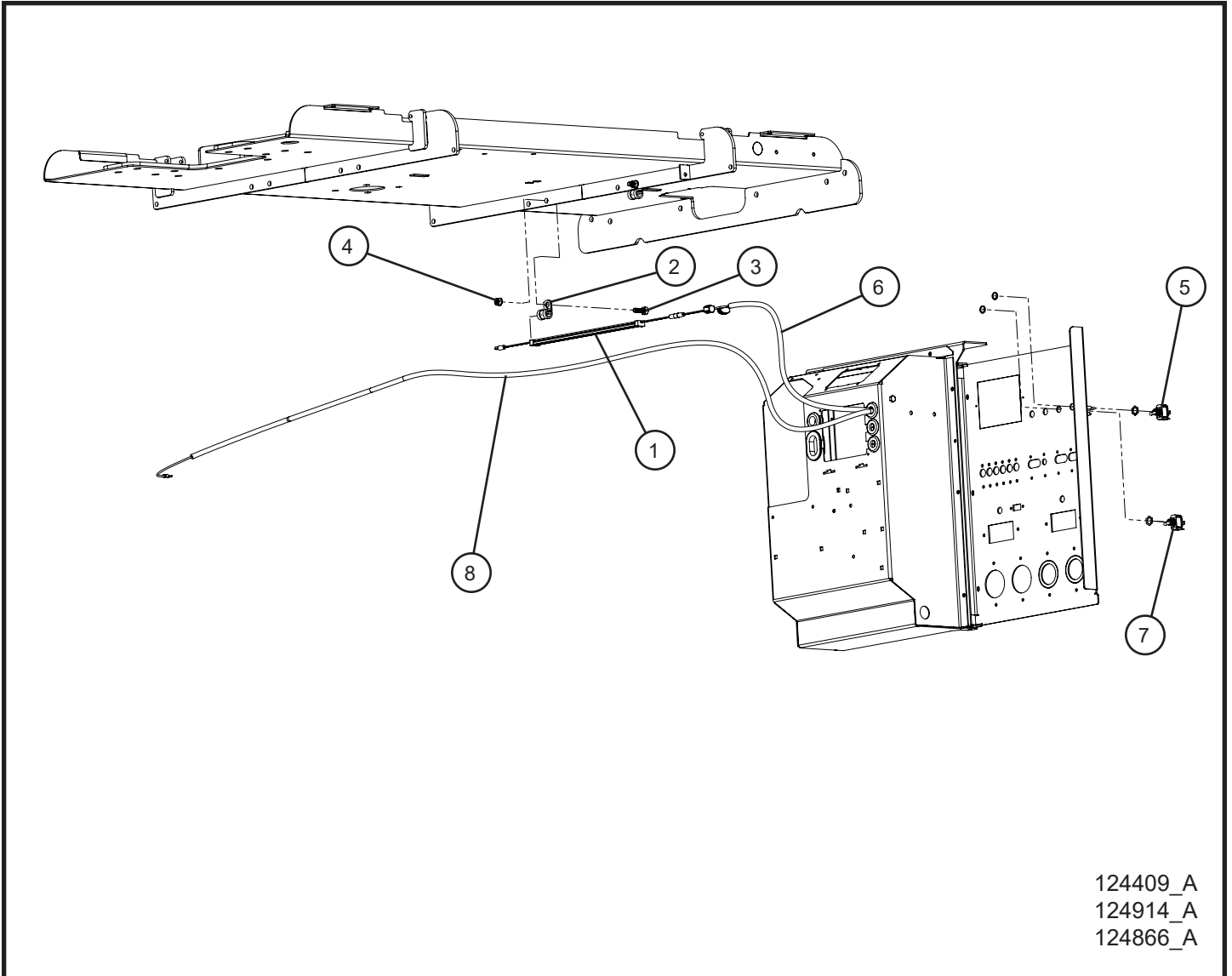

7.17 - Tower Toggle Switch and Interior Work Light

Item	Part No.	Part Description	Qty.
1	104820	12 INCH LED LIGHT	1
2	022018	#8 CUSH CLAMP	2
3	046050	5/16-18 x 1 HEX HEAD BOLT	2
4	044031	5/16-18 KEPS HEX NUT	2
5	123157	TOGGLE SWITCH SPST ON-OFF	1
6	115248	MAXI-LITE INTERIOR LIGHT 16/2 CORD x 48 INCHES	1
7	123158	TOGGLE SWITCH SPDT ON-OFF-ON	1
8	114031	MAXI-LITE HYDRAULIC SWITCH 16/2 CORD x 109 INCHES	1
NS	103864	FUSE HOLDER INLINE BLADE	1
NS	104990	2 AMP ATO/ATC BLADE FUSE	1
NS	115247	MAXI-LITE INTERIOR WORK LIGHT WIRE SCHEMATIC	1
NS	117947	MAXI-LITE ISUZU INTERIOR WORK LIGHT WIRE SCHEMATIC	1
NS	113143	HYDRAULIC VERTICAL KEY SWITCH POWERED SCHEMATIC	1

8.1 - Battery Cables I

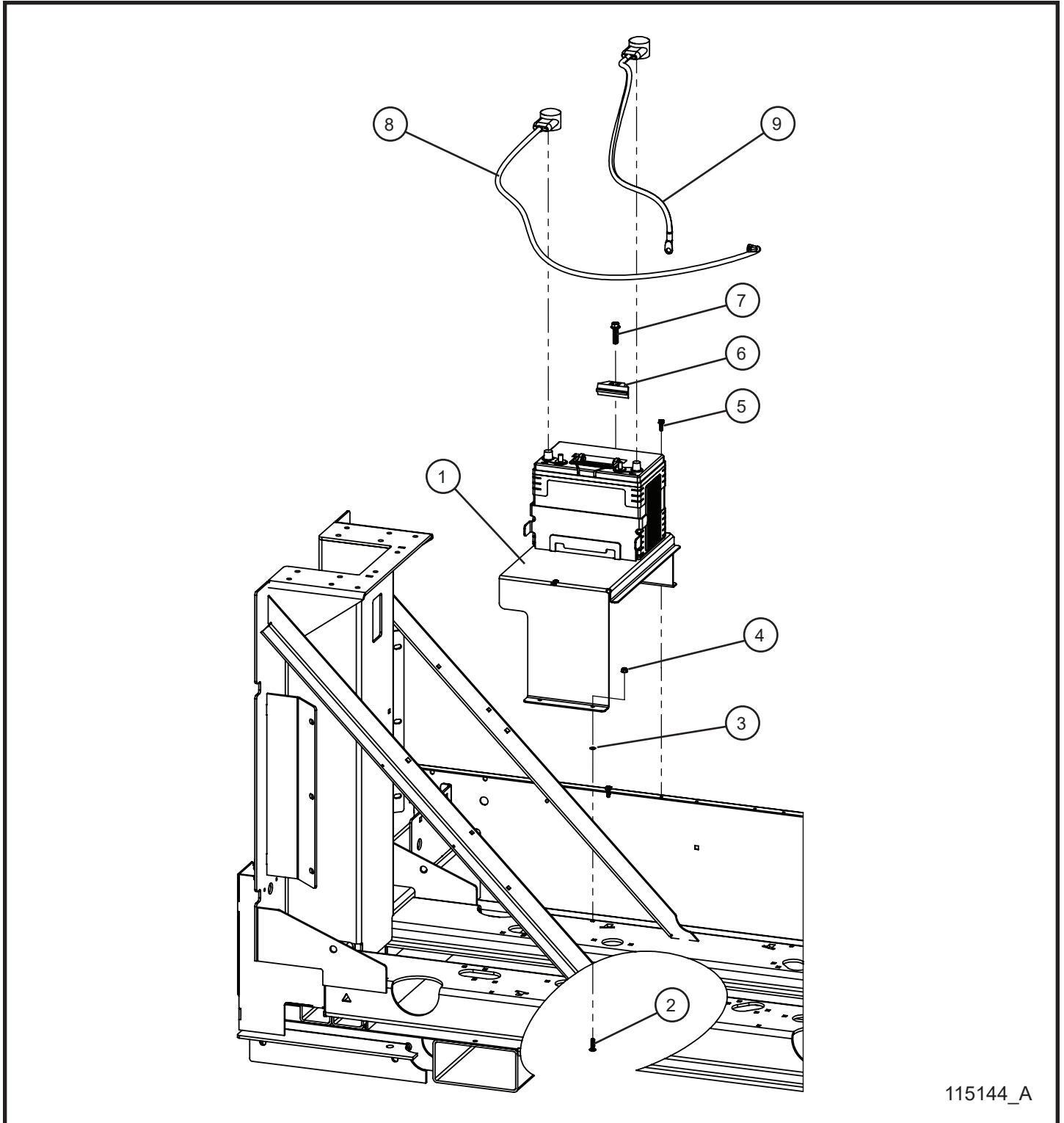

115144_A

8.1 - Battery Cables I

Item	Part No.	Part Description	Qty.
1	107311P	MAXI-LITE DUAL BATTERY MOUNT	1
2	100342	1/4-20 x 1 CARRIAGE BOLT	2
3	101701	1/4 PUSH NUT	2
4	057001	1/4-20 HEX NYLOCK FLANGE NUT	2
5	041070	1/4-20 x 3/4 SL-HEX WASHER HEAD MACHINE SCREW	2
6	107115	BATTERY HOLD DOWN	1
7	056015	3/8-16 x 1 1/2 HEX FLANGE SCREW	1
8	113656	2GA x 42.00 RED BATTERY CABLE	1
9	027015	2GA x 27.00 BLACK BATTERY CABLE	1

8.2 - Battery Cables II

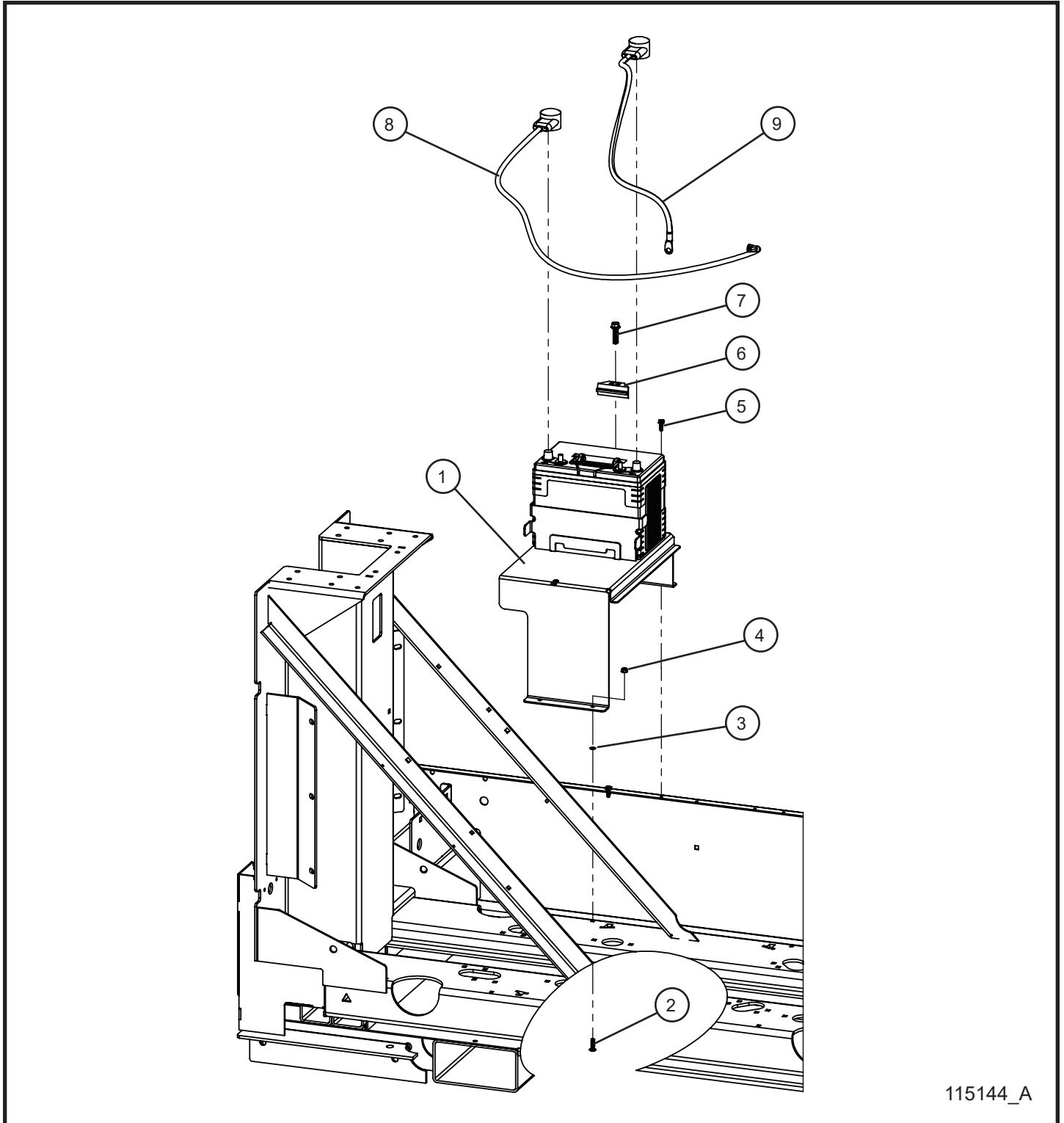

115144_A

8.2 - Battery Cables II

Item	Part No.	Part Description	Qty.
1	120059P	MAXI-LITE DUAL BATTERY MOUNT	1
2	100342	1/4-20 x 1 CARRIAGE BOLT	2
3	101701	1/4 PUSH NUT	2
4	057001	1/4-20 HEX NYLOCK FLANGE NUT	2
5	041070	1/4-20 x 3/4 SL-HEX WASHER HEAD MACHINE SCREW	2
6	107115	BATTERY HOLD DOWN	1
7	056015	3/8-16 x 1 1/2 HEX FLANGE SCREW	1
8	113656	2GA x 42.00 RED BATTERY CABLE	1
9	027015	2GA x 27.00 BLACK BATTERY CABLE	1

8.3 - Dual Battery Cables I

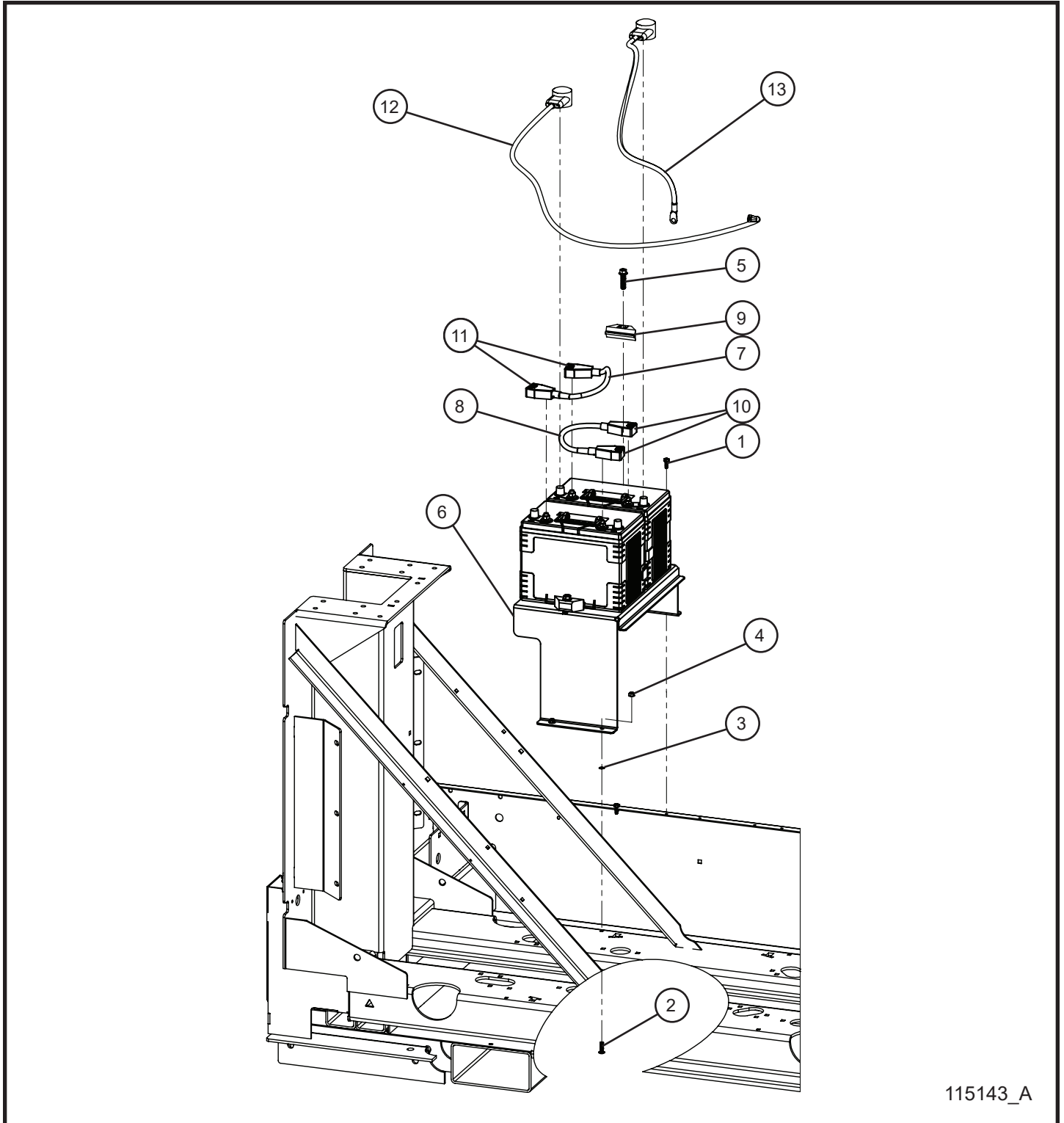

115143_A

8.3 - Dual Battery Cables I

Item	Part No.	Part Description	Qty.
1	041070	1/4-20 x 3/4 SL-HEX WASHER HEAD MACHINE SCREW	2
2	100342	1/4-20 x 1 CARRIAGE BOLT	2
3	101701	1/4 PUSH NUT	2
4	057001	1/4-20 HEX NYLOCK FLANGE NUT	2
5	056015	3/8-16 x 1 1/2 HEX FLANGE SCREW	2
6	107311P	MAXI-LITE DUAL BATTERY MOUNT	1
7	106466	MAXI-LITE NEGATIVE BATTERY PARALLEL CABLE	1
8	106467	MAXI-LITE POSITIVE BATTERY PARALLEL CABLE	1
9	107115	BATTERY HOLD DOWN	2
10	022055	RED BATTERY CABLE BOOT	2
11	022056	BLACK BATTERY CABLE BOOT	2
12	113656	2GA x 42.00 RED BATTERY CABLE	1
13	027015	2GA x 27.00 BLACK BATTERY CABLE	1

8.4 - Dual Battery Cables II

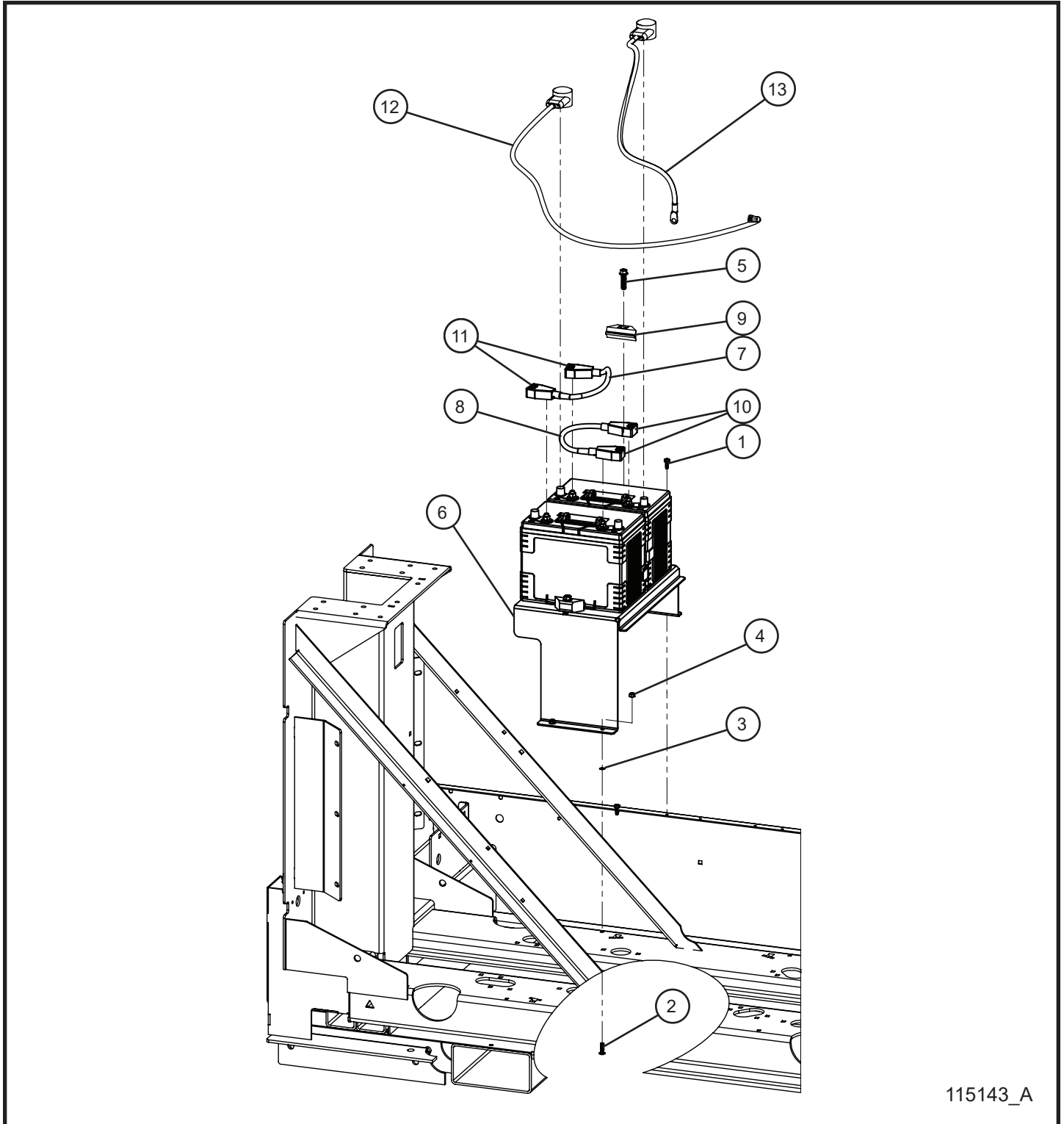

115143_A

8.4 - Dual Battery Cables II

Item	Part No.	Part Description	Qty.
1	041070	1/4-20 x 3/4 SL-HEX WASHER HEAD MACHINE SCREW	2
2	100342	1/4-20 x 1 CARRIAGE BOLT	2
3	101701	1/4 PUSH NUT	2
4	057001	1/4-20 HEX NYLOCK FLANGE NUT	2
5	056015	3/8-16 x 1 1/2 HEX FLANGE SCREW	2
6	120059P	MAXI-LITE DUAL BATTERY MOUNT	1
7	106466	MAXI-LITE NEGATIVE BATTERY PARALLEL CABLE	1
8	106467	MAXI-LITE POSITIVE BATTERY PARALLEL CABLE	1
9	107115	BATTERY HOLD DOWN	2
10	022055	RED BATTERY CABLE BOOT	2
11	022056	BLACK BATTERY CABLE BOOT	2
12	113656	2GA x 42.00 RED BATTERY CABLE	1
13	027015	2GA x 27.00 BLACK BATTERY CABLE	1

8.5 - Battery Disconnect Cables

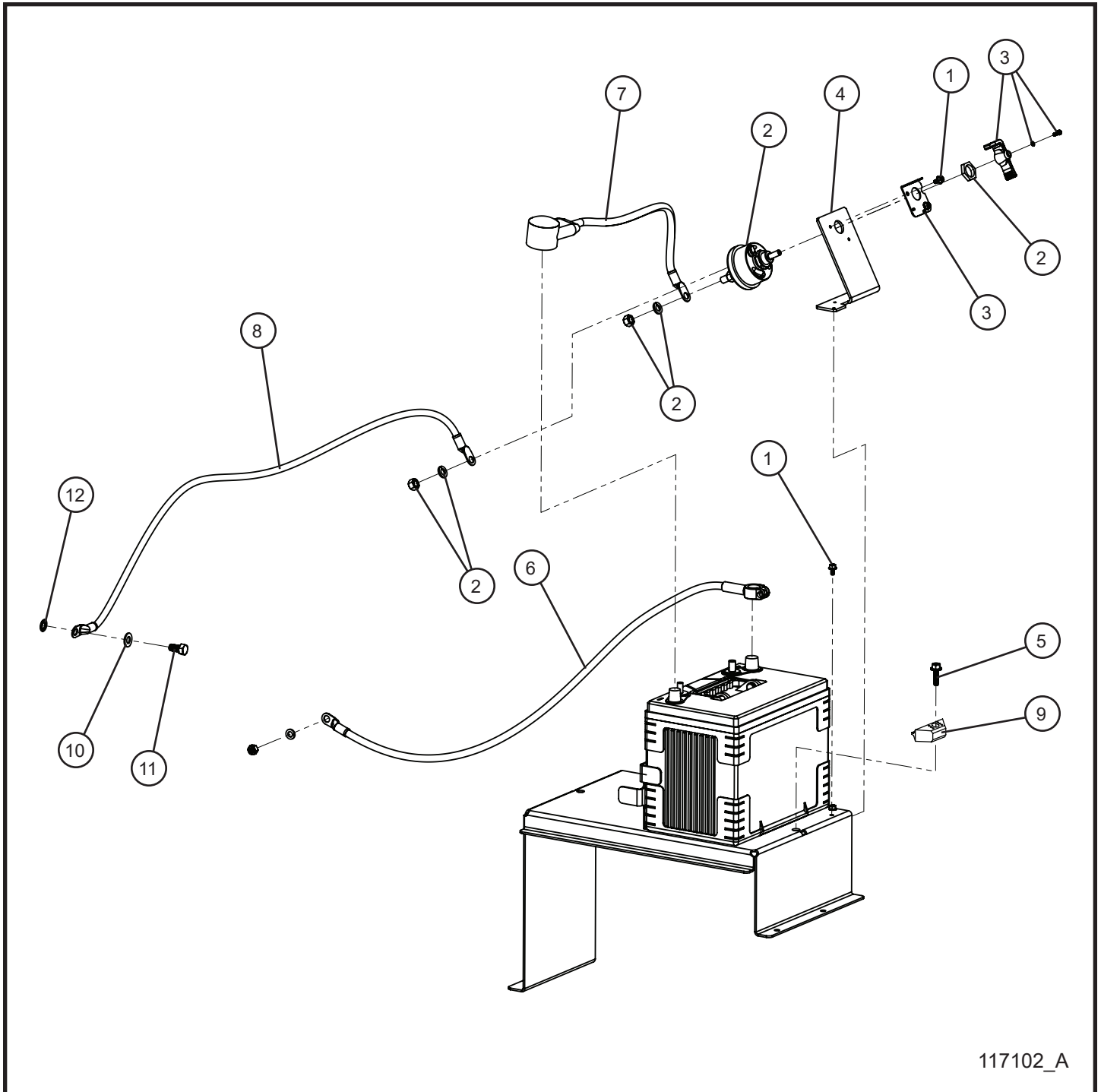

117102_A

8.5 - Battery Disconnect Cables

Item	Part No.	Part Description	Qty.
1	056016	#10-24 x 3/8 SERRATED FLANGE HEX BOLT	4
2	102534	4 TERMINAL BATTERY DISCONNECT SWITCH	1
3	103483	LOCK OUT BATTERY DISCONNECT	1
4	114659P	MAXI-LITE BATTERY DISCONNECT MOUNT	1
5	056015	3/8-16 x 1 1/2 HEX FLANGE SCREW	1
6	113656	2GA x 42.00 RED BATTERY CABLE	1
7	110373	2GA x 16.00 BLACK BATTERY CABLE	1
8	105111	2GA x 42.00 BLACK BATTERY CABLE	1
9	107115	BATTERY HOLD DOWN	1
10	047016	3/8 FLAT WASHER	1
11	046105	3/8-16 x 3/4 HEX HEAD BOLT	1
12	043070	3/8 INTL TOOTH LOCK WASHER	1
NS	105301	BATTERY DISCONNECT SCHEMATIC	1

8.6 - Side Marker Lights and Tail Lights

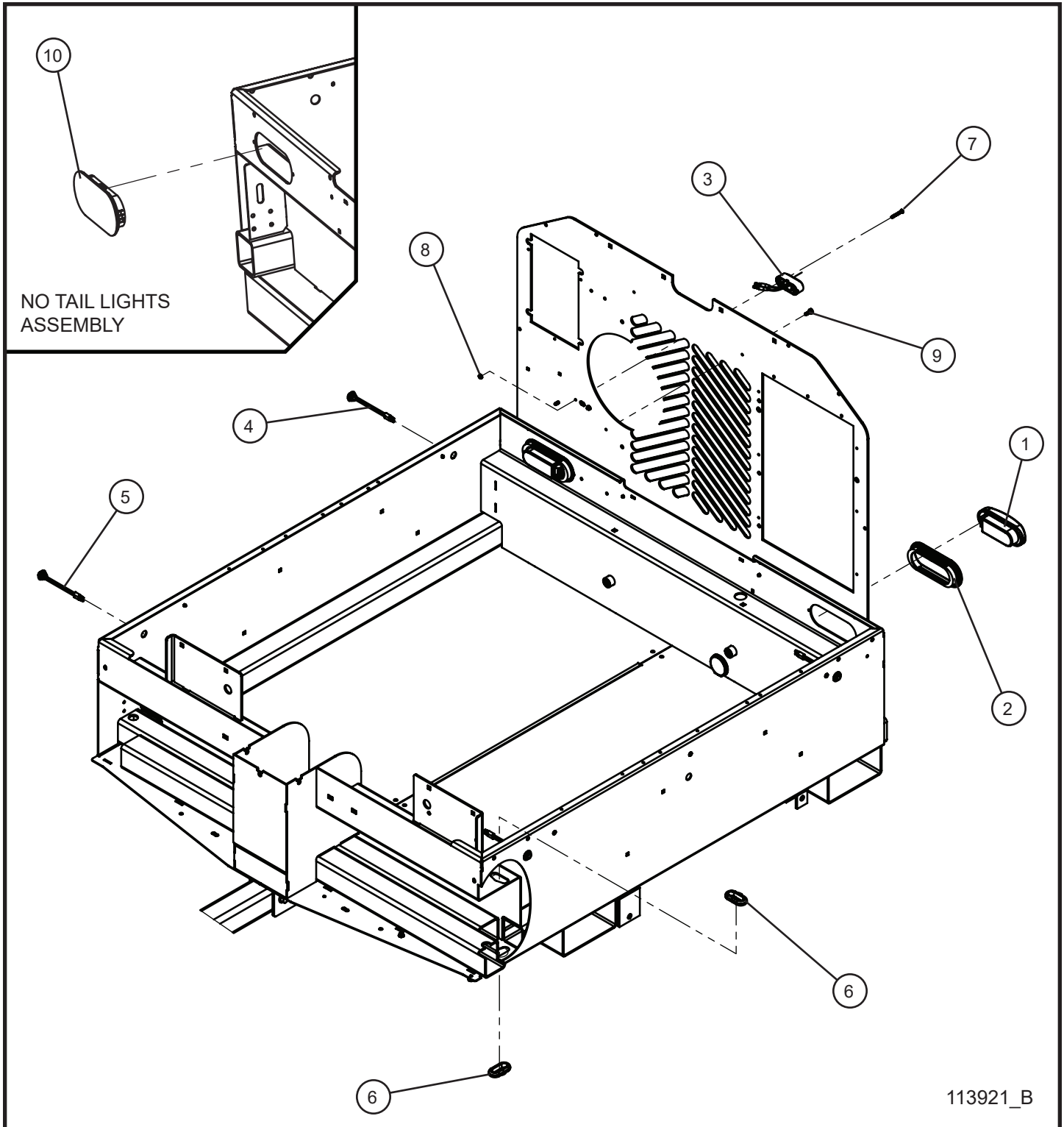

113921_B

8.6 - Side Marker Lights and Tail Lights

Item	Part No.	Part Description	Qty.
1	102721	LED TAIL LAMP	2
2	102825	GROMMET	2
3	115116	LICENSE PLATE LED LIGHT	1
4	106211	RED BULLET LED MARKER LIGHT	2
5	106212	AMBER BULLET LED MARKER LIGHT	2
6	106542	RUBBER GROMMET	2
7	041040	#10-24 x 1 1/2 PH-ROUND HEAD MACHINE SCREW	2
8	044016	#10-24 KEPS HEX NUT	2
9	041070	1/4-20 x 3/4 SL-HEX WASHER HEAD MACHINE SCREW	2
10	118601	TAILLIGHT PLASTIC FILLER PLUG (2 SET)	1
NS	113663	MAXI-LITE TAIL LIGHT BASE HARNESS	1
NS	113861	BREAK AWAY KIT TAIL LIGHT HARNESS	1
NS	114032	MAXI-LITE ELECTRIC BRAKE TAIL LIGHT HARNESS SCHEMATIC	1

8.6 - Side Marker Lights and Tail Lights

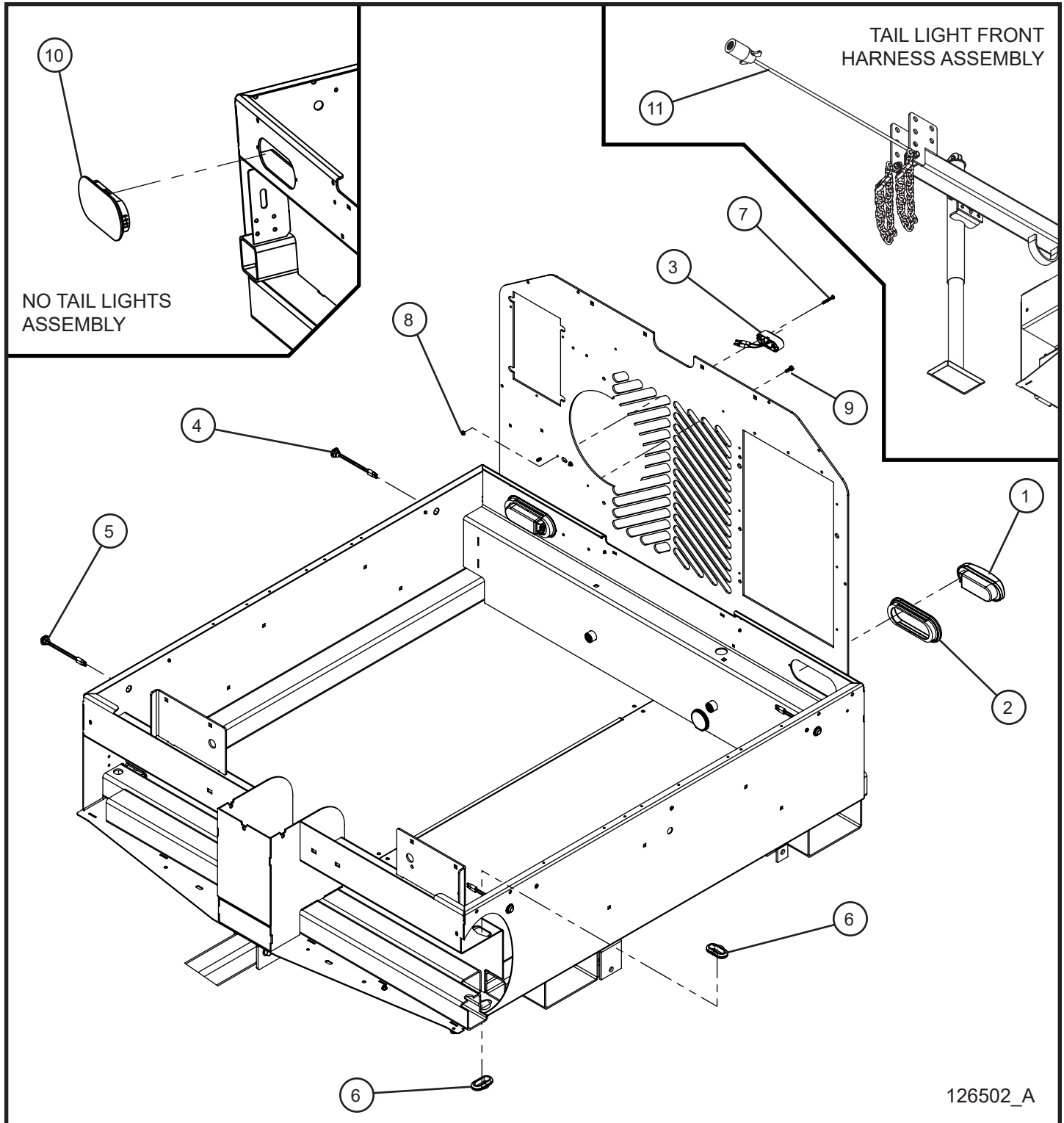

8.6 - Side Marker Lights and Tail Lights

Item	Part No.	Part Description	Qty.
1	102721	LED TAIL LAMP	2
2	102825	GROMMET	2
3	115116	LICENSE PLATE LED LIGHT	1
4	106211	RED BULLET LED MARKER LIGHT	2
5	106212	AMBER BULLET LED MARKER LIGHT	2
6	106542	RUBBER GROMMET	2
7	041040	#10-24 x 1 1/2 PH-ROUND HEAD MACHINE SCREW	2
8	044016	#10-24 KEPS HEX NUT	2
9	041070	1/4-20 x 3/4 SL-HEX WASHER HEAD MACHINE SCREW	2
10	118601	TAILLIGHT PLASTIC FILLER PLUG (2 SET)	1
11	125532	HARNESS TAILLIGHT ARCTIC BREAKAWAY ML, MP15XR, & HLT	1
NS	113663	MAXI-LITE TAIL LIGHT BASE HARNESS	1
NS	113861	BREAK AWAY KIT TAIL LIGHT HARNESS	1
NS	114032	MAXI-LITE ELECTRIC BRAKE TAIL LIGHT HARNESS SCHEMATIC	1

8.7 - Breakaway Kit I

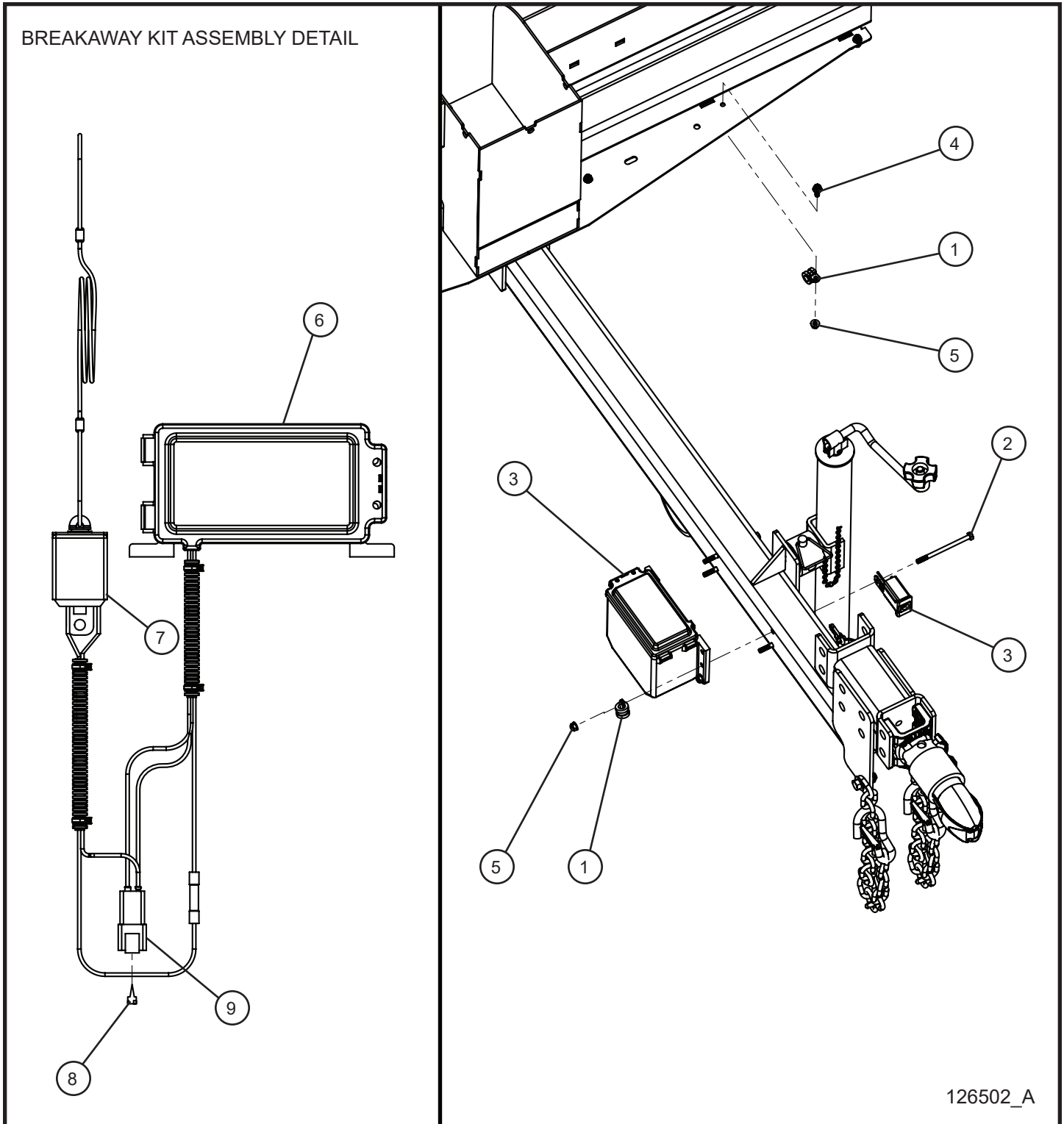

8.7 - Breakaway Kit I

Item	Part No.	Part Description	Qty.
1	310212	#10 CUSH CLAMP 1/4 HOLE	4
2	046039	1/4-20 x 4 HEX HEAD BOLT	4
3	113855	MAXI-LITE BREAK AWAY KIT ASSEMBLY	1
4	056002	1/4-20 x 3/4 HEX SERRATED FLANGE SCREW	3
5	057001	1/4-20 HEX NYLOCK FLANGE NUT	7
6	106578	BREAKAWAY KIT	1
7	113065	BREAKAWAY SWITCH AND LANYARD ASSEMBLY	1
8	105847	4-WAY RECEPTACLE WEDGELOCK	1
9	105207	4-WAY RECEPTACLE	1
NS	126700	MAXI-LITE BREAKAWAY SYSTEM REPLACEMENT KIT	1
NS	113663	MAXI-LITE TAIL LIGHT BASE HARNESS	1
NS	125532	HARNESS TAILLIGHT ARCTIC BREAKAWAY ML, MP15XR, & HLT	1
NS	113861	BREAK AWAY KIT TAIL LIGHT HARNESS	1
NS	114032	MAXI-LITE ELECTRIC BRAKE TAIL LIGHT HARNESS SCHEMATIC	1

8.8 - Breakaway Kit II

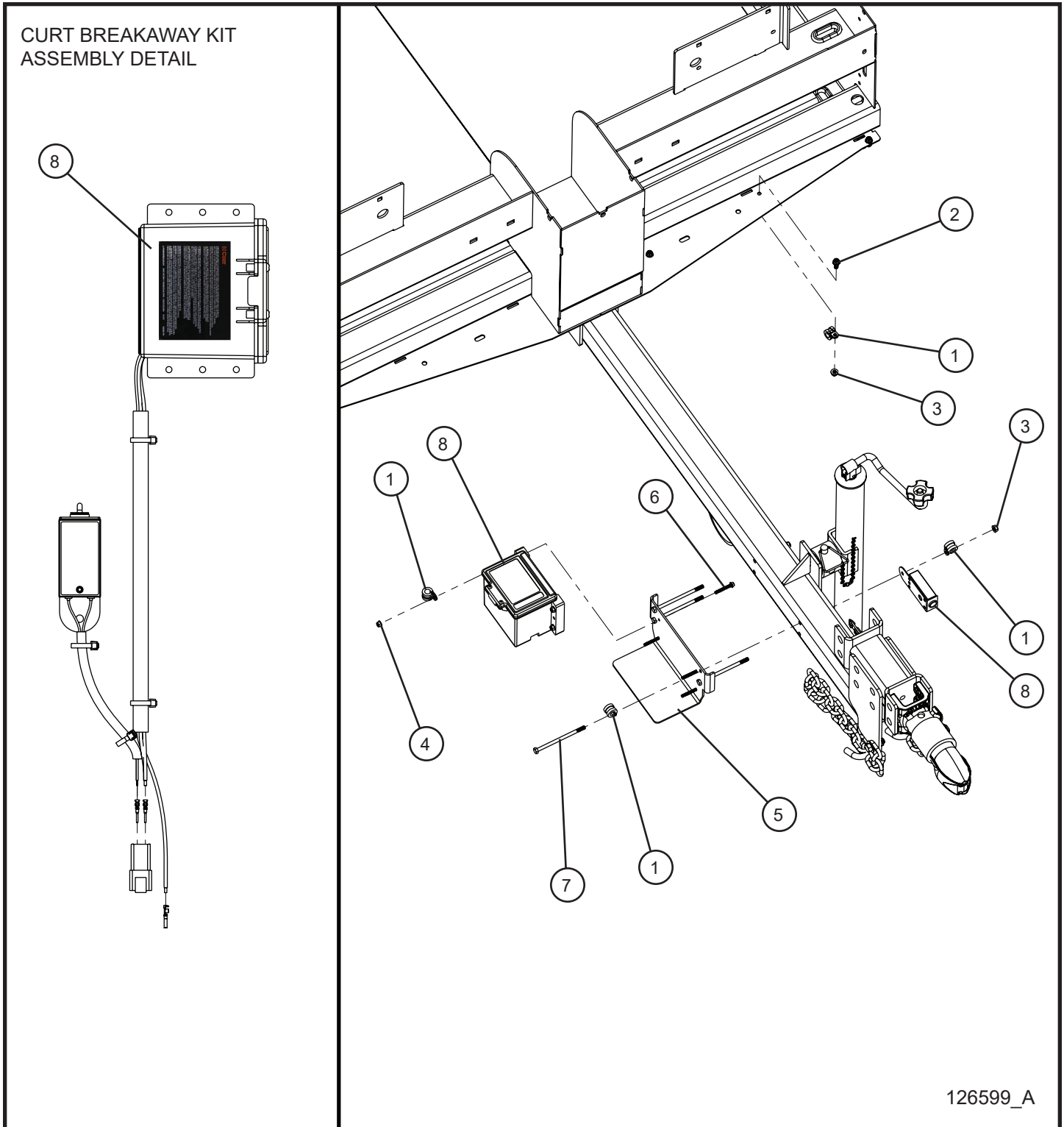

8.8 - Breakaway Kit II

Item	Part No.	Part Description	Qty.
1	310212	#10 CUSH CLAMP 1/4 HOLE	4
2	056002	1/4-20 x 3/4 HEX SERRATED FLANGE SCREW	3
3	057001	1/4-20 HEX NYLOCK FLANGE NUT	7
4	057010	#10-24 HEX NYLOCK FLANGE NUT	4
5	126664P	PLATE MOUNT BREAKAWAY BATTERY ML, MP15XR & HYBRID	1
6	056047	#10-24 X 1-1/2 HEX SERRATED FLANGE SCREW	4
7	046042	1/4-20 X 4 1/2 HEX HEAD CS	4
8	126663	CURT BREAKAWAY KIT ASSEMBLY MAXI-LITE	1
NS	113663	MAXI-LITE TAIL LIGHT BASE HARNESS	1
NS	125532	HARNESS TAILLIGHT ARCTIC BREAKAWAY ML, MP15XR, & HLT	1
NS	126666	SCHEMATIC CURT BREAK AWAY KIT ML MP15XR & HYBRID	1
NS	114032	MAXI-LITE ELECTRIC BRAKE TAIL LIGHT HARNESS SCHEMATIC	1

8.9 - Emergency Stop

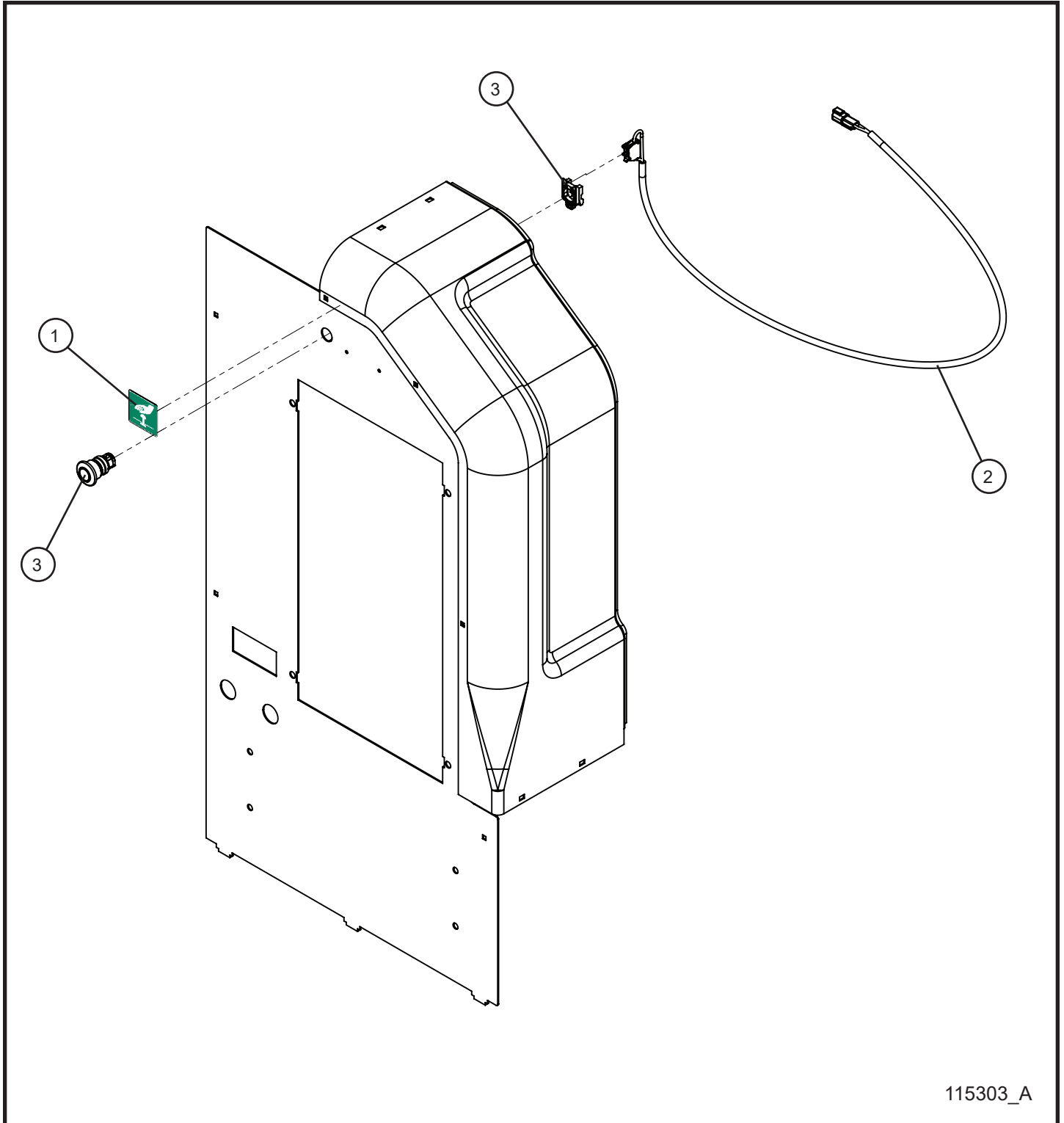

115303_A

8.9 - Emergency Stop

Item	Part No.	Part Description	Qty.
1	105567	EMERGENCY STOP DECAL	1
2	105991	MAXI-LITE EMERGENCY STOP WIRE HARNESS	1
3	108912	40mm PUSH-PULL EMERGENCY STOP 22mm MOUNTING	1

8.10 - Low Fuel and Run Beacons

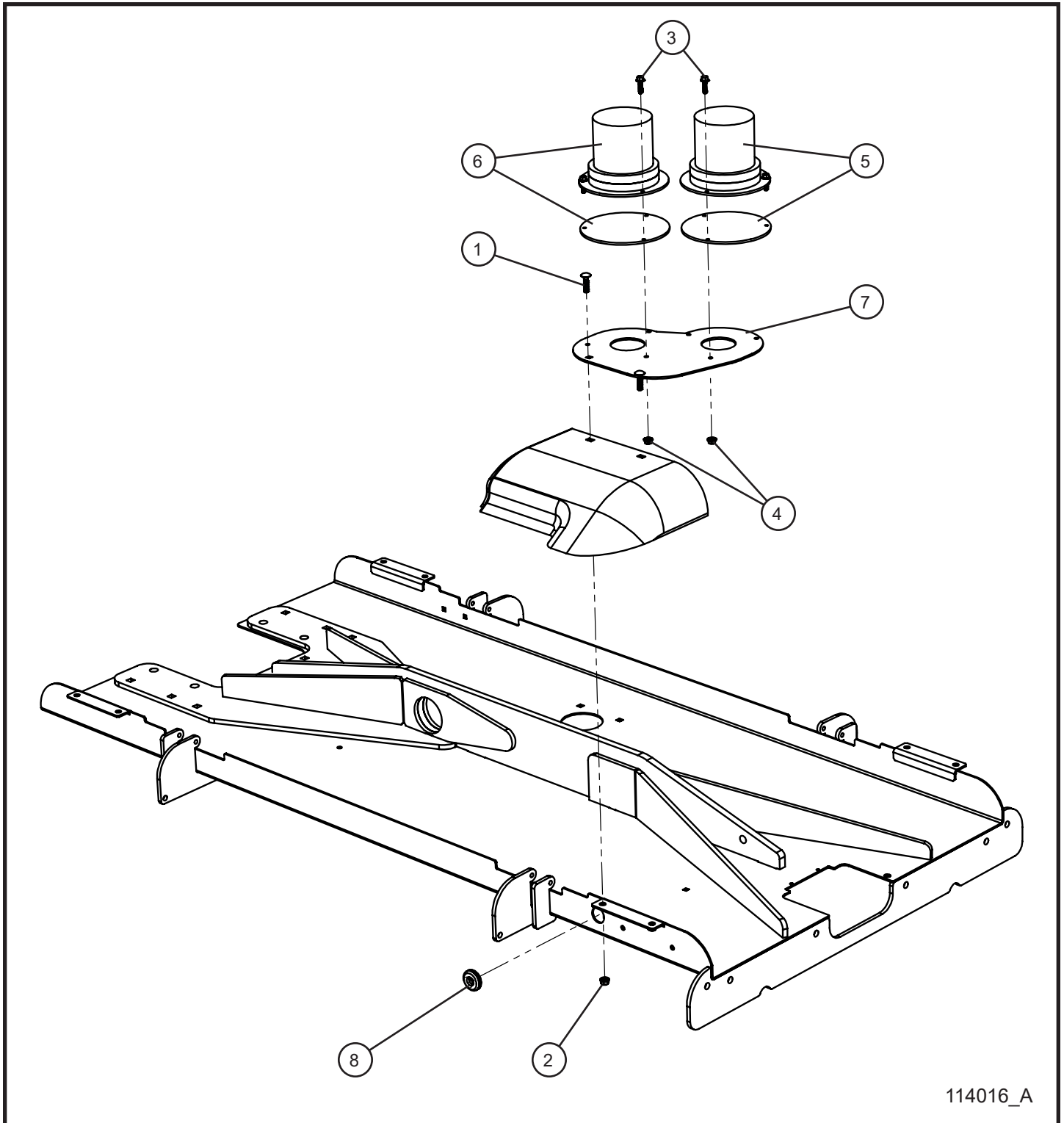

114016_A

8.10 - Low Fuel and Run Beacons

Item	Part No.	Part Description	Qty.
1	046036	1/4-20 x 1 CARRIAGE BOLT	2
2	057001	1/4-20 HEX NYLOCK FLANGE NUT	2
3	056005	#10-24 X 3/4 SERRATED FLANGE HEX SCREW	6
4	057004	#10-24 SERRATED FLANGE HEX NUT	6
5	118616	GREEN STROBE LIGHT	1
6	120562	AMBER BEACON LIGHT SUB-ASSEMBLY	1
	118615	AMBER STROBE LIGHT	1
	114019	HARNESS LOW FUEL & RUN LIGHT BEACONS MAXI	1
7	120392P	BEACON BRACKET MAXI-LITE	1
8	100859	7/8 ID X 1 1/4 OD GROMMET	1
NS	105887	LOW FUEL BEACON SCHEMATIC	1
NS	120566	SCHEMATIC RUN BEACON MAXI-LITE DEEP SEA	1
NS	022200	1/4 FLEX LOOM X 12.00	2
NS	110088	FUEL LEVEL SENDER	1
NS	110090	HARNESS SENDER	1

9.1 - Engine Isolator Mount Group

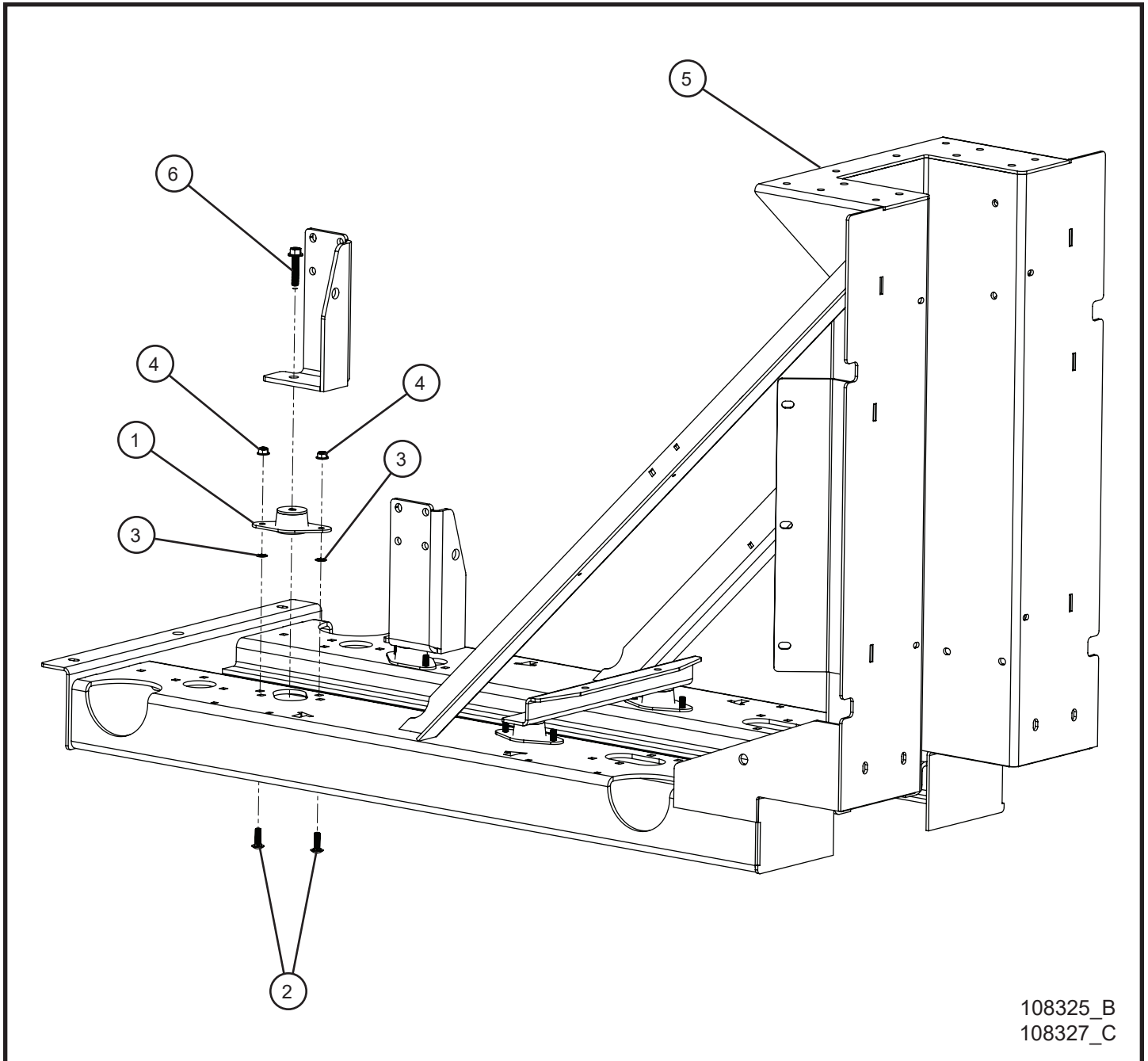

108325_B
108327_C

9.1 - Engine Isolator Mount Group

Item	Part No.	Part Description	Qty.
1	107028	LIGHT DUTY ENGINE ISOLATOR MOUNT	4
	125118	HEAVY DUTY ENGINE ISOLATOR MOUNT	4
2	053020	5/16-18 x 1 CARRIAGE BOLT	8
3	045217	5/16 PUSH NUT	8
4	057008	5/16-18 HEX NYLOCK FLANGE NUT	8
5	113631P	ENGINE CRADLE REINFORCED MAXI-LITE II	1
6	056013	3/8-16 x 1 3/4 SERRATED FLANGE BOLT WITH THREAD LOCK	4

9.2 - Engine Isolator Mount Group Isuzu

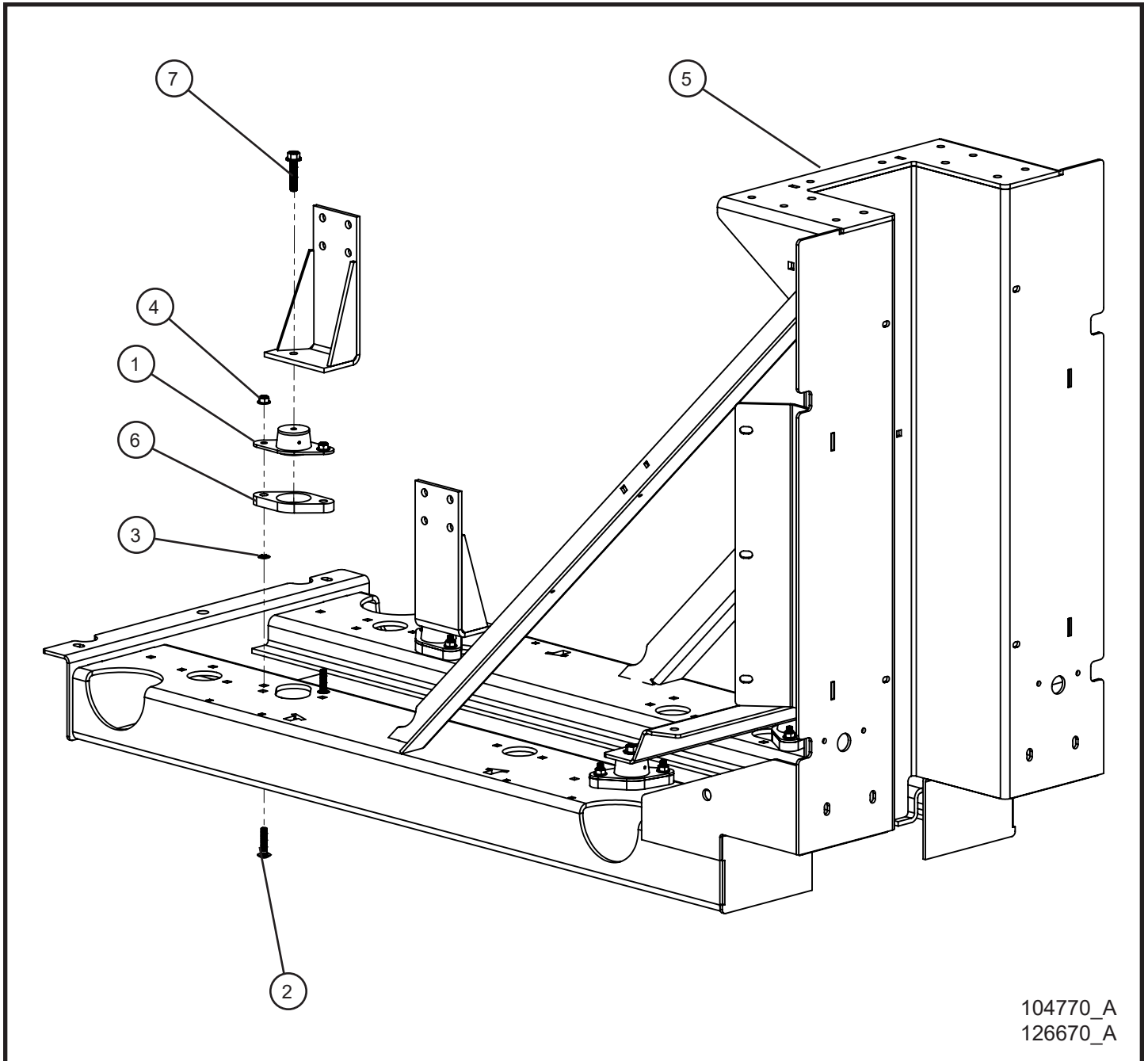

9.2 - Engine Isolator Mount Group Isuzu

Item	Part No.	Part Description	Qty.
1	107028	LIGHT DUTY ENGINE ISOLATOR MOUNT	4
	125118	HEAVY DUTY ENGINE ISOLATOR MOUNT	4
2	053023	5/16-18 X 1 1/2 CARRIAGE BOLT	8
3	045217	5/16 PUSH NUT	8
4	057008	5/16-18 HEX NYLOCK FLANGE NUT	8
5	113631P	ENGINE CRADLE REINFORCED MAXI-LITE II	1
6	104696P	PLATE SPACER 1/2" ENGINE ISOLATOR	1
7	056013	3/8-16 x 1 3/4 SERRATED FLANGE BOLT WITH THREAD LOCK	4

9.3 - Fluid Containment Drain Cap

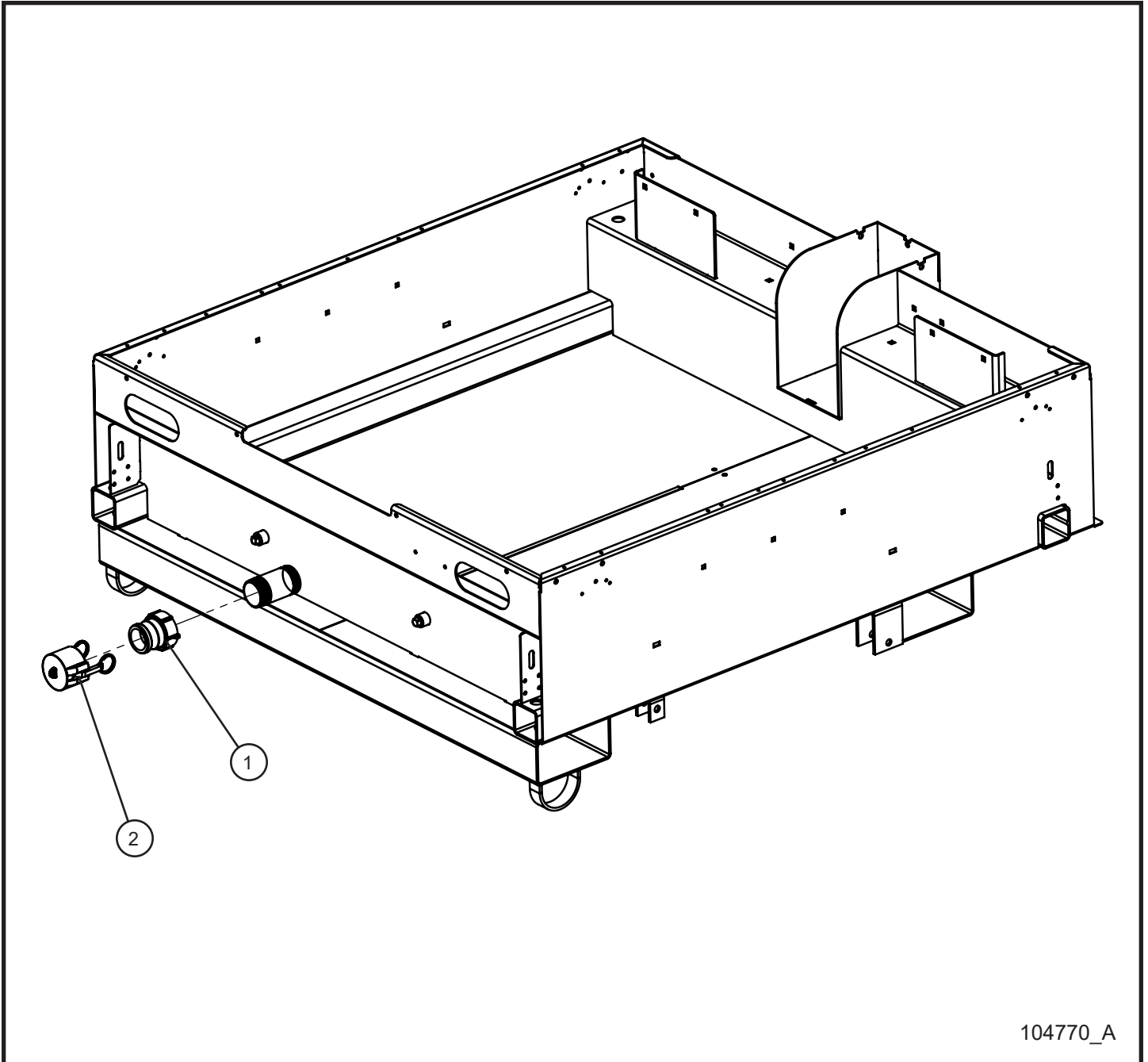

104770_A

9.3 - Fluid Containment Drain Cap

Item	Part No.	Part Description	Qty.
1	104464	PIPE CONNECTION 2 INCH COUPLING	1
2	104463	CAP 2 INCH COUPLING	1

9.4 - Fuel Tanks

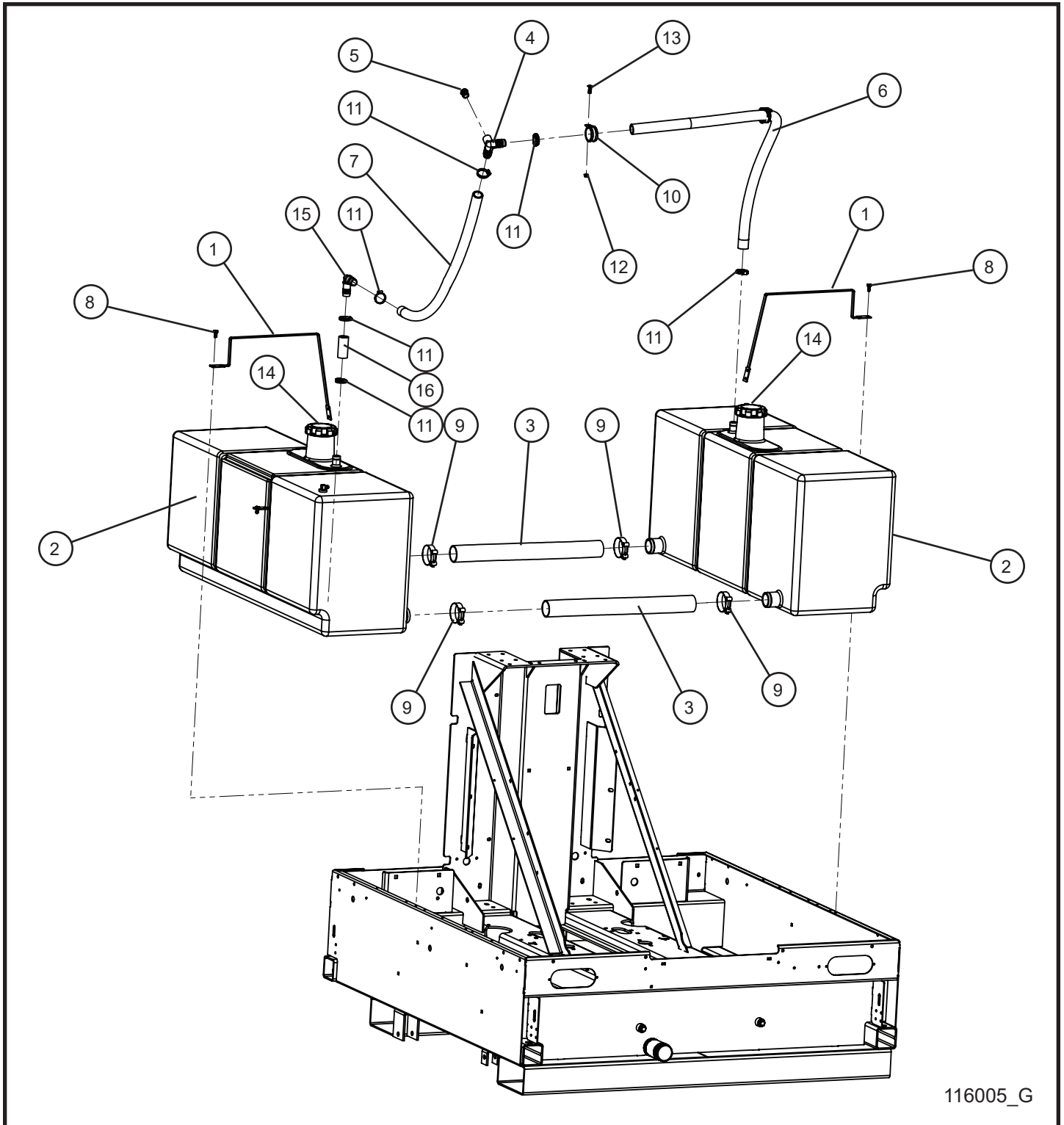

116005_G

9.4 - Fuel Tanks

Item	Part No.	Part Description	Qty.
1	104698P	STRAP TIEDOWN FUEL TANK	3
2	107062	FUEL TANK 51.5 GALLON FAST FILL	2
3	104383	CROSSOVER HOSE FUEL TANKS	2
4	106131	PVC Y FITTING 1 x 1 x 1/2 NPT	1
5	106132	FITTING BREATHER 1/2 NPT	1
6	125072	1" ID VENT HOSE x 53.00	1
7	125072	1" ID VENT HOSE x 26.00	1
8	041070	1/4-20 x 3/4 SL-HEX WASHER HEAD MACHINE SCREW	3
9	125421	FLEX GEAR CLAMP IDEA TRIDON 47036	4
10	106144	1 1/2 CUSH CLAMP W/ 3/8 HOLE	2
11	045034	#16 HOSE CLAMP	6
12	100342	1/4-20 x 1 CARRIAGE BOLT	2
13	057001	1/4-20 HEX NYLOCK FLANGE NUT	2
14	125161	FUEL CAP NON-VENTED 3.5 BLACK WITH LANYARD	2
15	123282	1 X 1 90 DEGREE PVC HOSE BARB ELBOW	1
16	125072	1" ID VENT HOSE X 3.00	1
NS	106153	FUEL SUCTION TUBE ASSEMBLY	2
	340025C	DAPCO GROMMET	2
NS	047010	5/16 FLAT WASHER	3
NS	101701	1/4 PUSH NUT	2

9.5 - Fuel Level Sender

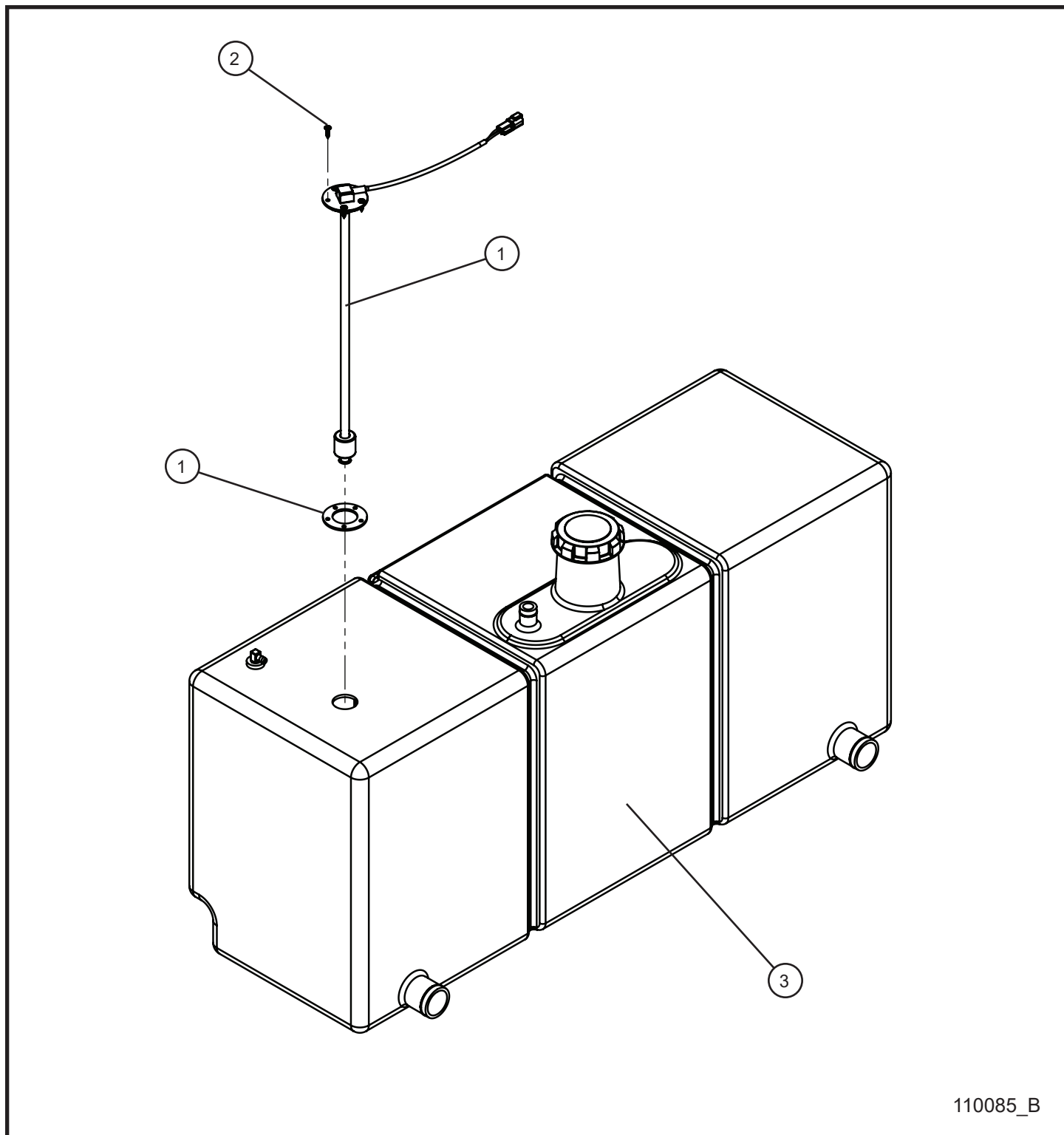

110085_B

9.5 - Fuel Level Sender

Item	Part No.	Part Description	Qty.
1	110088	VERTICAL SHAFT FUEL LEVEL SENDER	1
2	102556	SCREW #8 x 3/4	5
3	107062	FUEL TANK 51.5 GALLON FAST FILL	2
NS	110090	HARNESS SENDER FUEL LEVEL	1
NS	110089	LOW FUEL SENDER WIRE SCHEMATIC	1

9.6 - Heated Fuel/Water Separator (1 of 2)

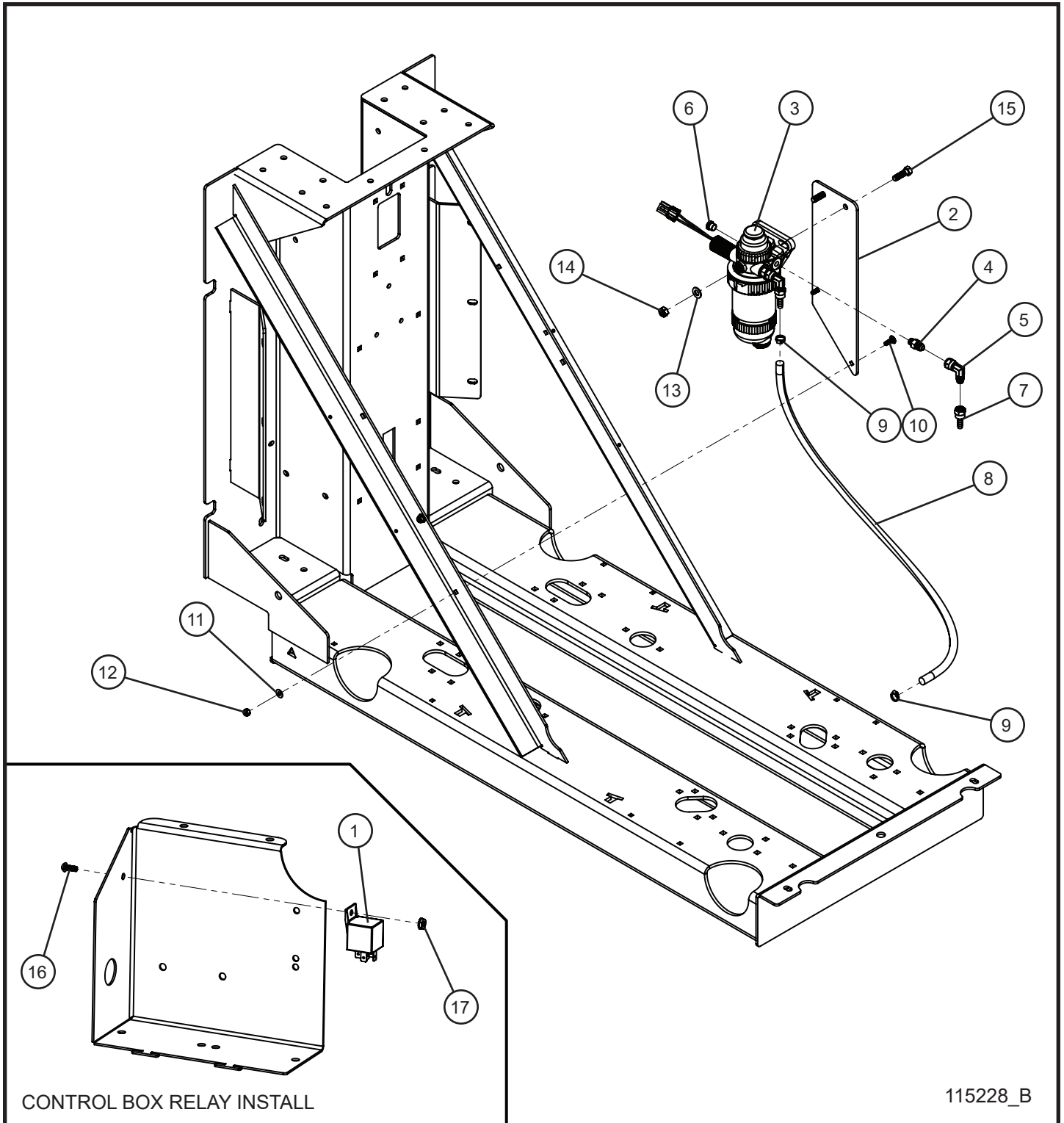

9.6 - Heated Fuel/Water Separator (1 of 2)

Item	Part No.	Part Description	Qty.
1	104254	RELAY 12V 40AMP	1
2	104630P	PLATE MOUNT WATER SEPARATOR	1
3	118676	HEATER PREFILTER ASSY STANADYNE	1
4	100655	1/2-20 x -6 JIC STRAIGHT CONNECTOR	2
5	101263	-6 JIC 90° SWIVEL FITTING	2
6	101267	1/2-20 HOLLOW HEX PLUG	1
7	106030	-6 JIC 5/16 FITTING HOSE BARB	2
8	081018	HOSE 5/16 x 40.0	1
9	433400	#4 HOSE CLAMP	2
10	053102	1/4-20 x 3/4 CARRIAGE BOLT	2
11	047009	1/4 FLAT WASHER	2
12	044023	1/4-20 NYLOCK HEX NUT	2
13	047016	3/8 FLAT WASHER	2
14	044038	3/8-16 NYLOCK HEX NUT	2
15	046115	3/8-16 x 1 1/4 HEX HEAD BOLT	2
16	041021	#10-24 x 1/2 PH-ROUND HEAD MACHINE SCREW	1
17	044016	#10-24 KEPS HEX NUT	1
NS	118686	REPLACEMENT FILTER ELEMENT	1
NS	100613	STANDADYNE HEATER ELEMENT	1
NS	105886	HEATED FUEL WATER SEPARATOR SCHEMATIC	1

9.6 - Heated Fuel/Water Separator (2 of 2)

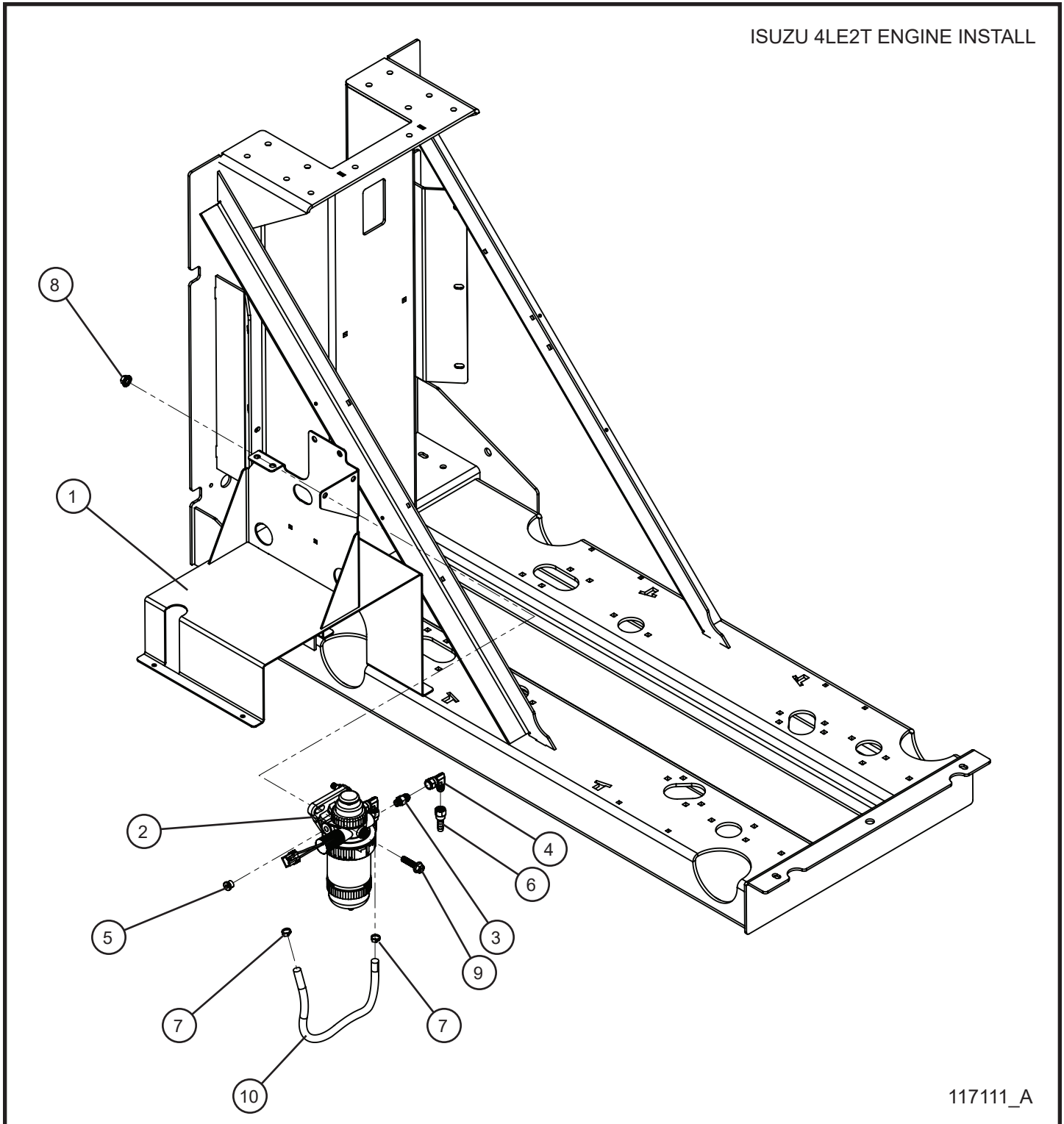

117111_A

9.6 - Heated Fuel/Water Separator (2 of 2)

Item	Part No.	Part Description	Qty.
1	107007P	ISUZU 4LE2T FUEL FILTER & PUMP BRACKET	1
2	118676	HEATER PREFILTER ASSY STANADYNE	1
3	100655	1/2-20 x -6 JIC STRAIGHT CONNECTOR	2
4	101263	-6 JIC 90° SWIVEL FITTING	2
5	101267	1/2-20 HOLLOW HEX PLUG	1
6	101293	3/8 HOSE BARB x 3/8	2
7	433400	#4 HOSE CLAMP	2
8	044029	3/8-16 SERRATED FLANGE NUT	2
9	046115	3/8-16 x 1 1/2 HEX FLANGE SCREW	2
10	101226	3/8 SAE 30R7 HOSE x 22.00	1
NS	118686	REPLACEMENT FILTER ELEMENT	1
NS	100613	STANDADYNE HEATER ELEMENT	1
NS	117335	ISUZU HEATED FUEL WATER SEPARATOR SCHEMATIC	1

9.7 - Radiator Coolant Recovery Tank

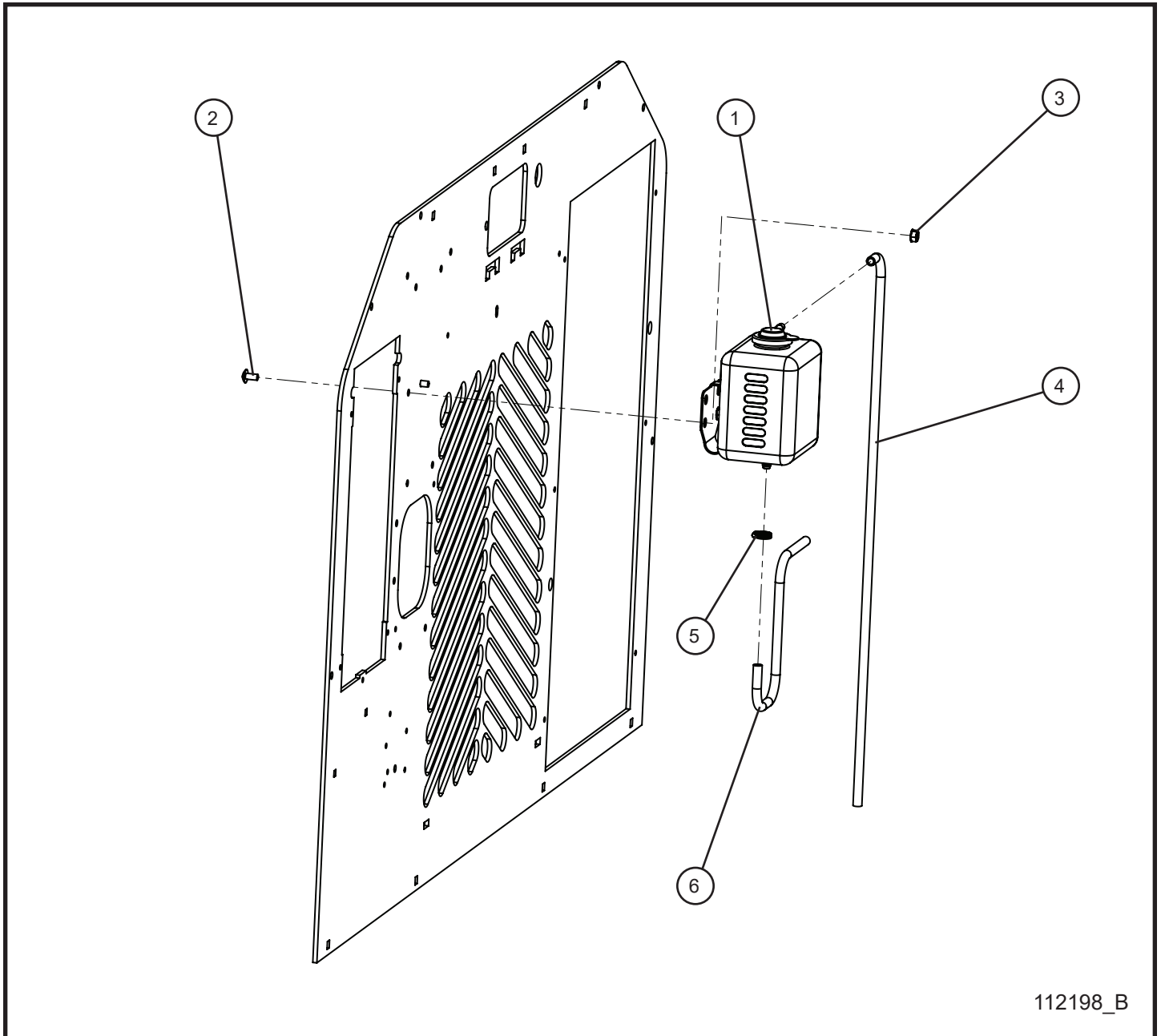

9.7 - Radiator Coolant Recovery Tank

Item	Part No.	Part Description	Qty.
1	650027	RESERVOIR WITH BRACKET	1
2	041078	1/4-20 x 1/2 PH-TRUSS HEAD MS SS	2
3	044021	1/4-20 KEPS HEX NUT PL	2
4	102268	COOLANT HOSE 1/4 x 44.0	1
5	433400	#4 HOSE CLAMP	1
6	102268	COOLANT HOSE 1/4 x 28.0	1

9.8 - Power Lug Panel Radiator Coolant Recovery Tank

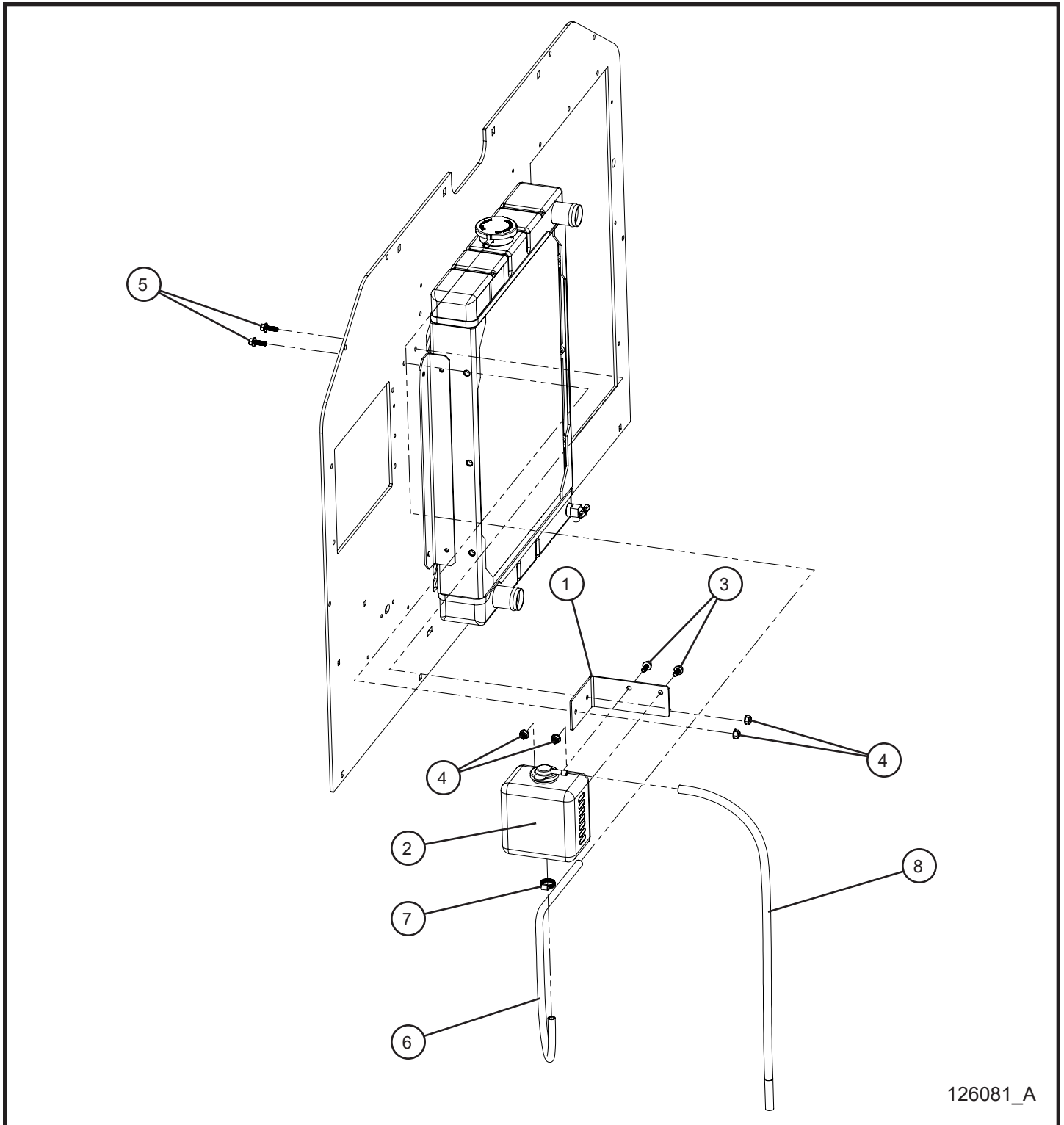

126081_A

9.8 - Power Lug Panel Radiator Coolant Recovery Tank

Item	Part No.	Part Description	Qty.
1	124989P	BRACKET COOLANT OVERFLOW BOTTLE MAXI-LITE MP15XR	1
2	650027	RESERVOIR WITH BRACKET	1
3	056040	1/4-20 X 5/8 HEX FLANGE SCREW	2
4	057001	1/4 - 20 HEX NYLOCK FLANGE NUT	4
5	056019	1/4-20 X 3/4 HEX FLANGE SCREW	2
6	102268	COOLANT HOSE 1/4 x 21.0	1
7	433400	#4 HOSE CLAMP	1
8	102268	COOLANT HOSE 1/4 x 44.0	1

9.9 - Radiator Coolant Drain Group

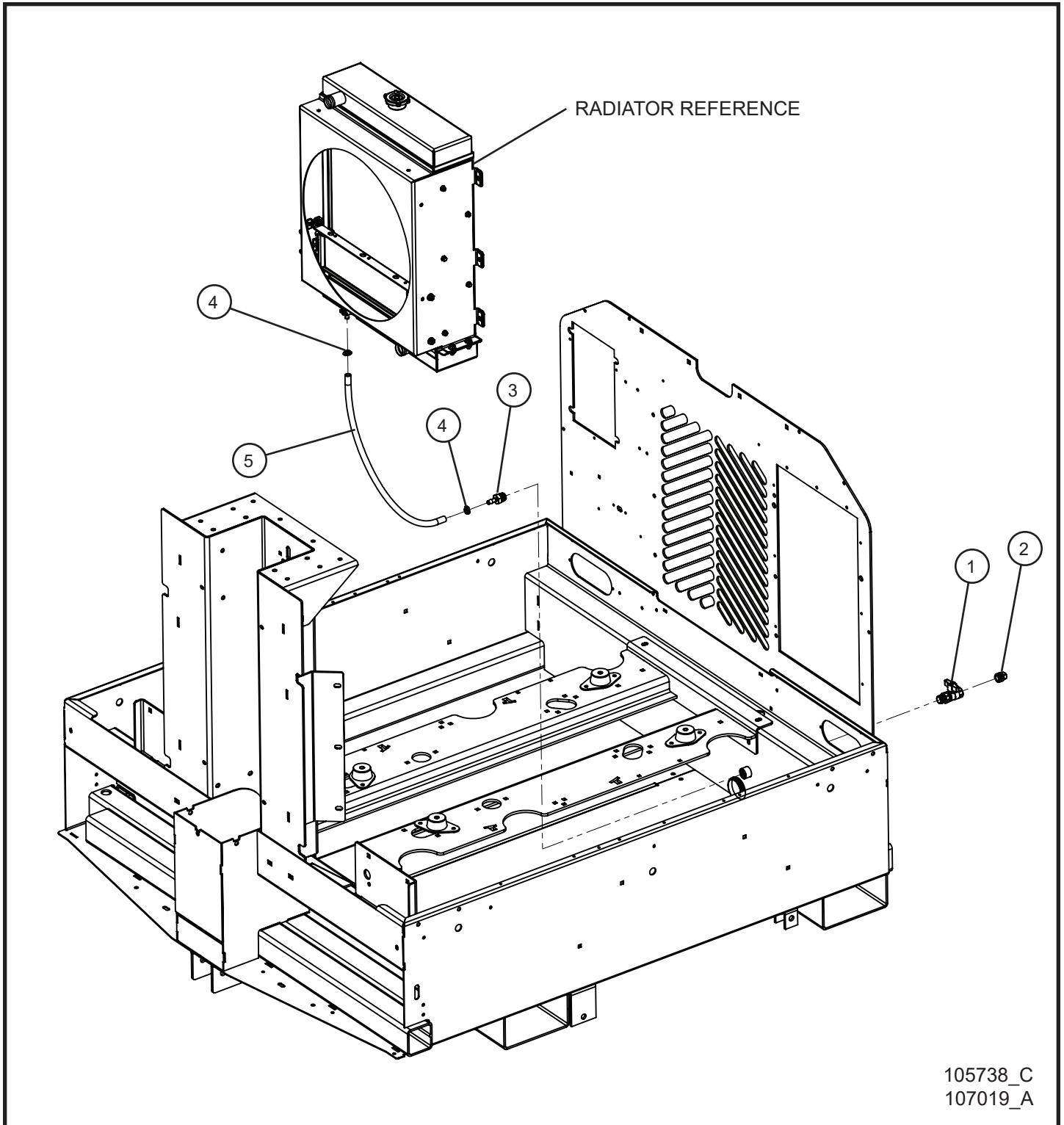

105738_C
107019_A

9.9 - Radiator Coolant Drain Group

Item	Part No.	Part Description	Qty.
1	125254	BALL VALVE 1/2 NPT MALE X 1/2 NPT FEMALE	1
2	026106	1/2 NPT SQUARE HEAD PLUG	1
3	104381	1/2 NPT - 3/8 HOSE BARB FITTING	1
4	433400	#4 HOSE CLAMP	2
5	101266	3/8 COOLANT HOSE x 21.00 (JB/RCP RADIATOR)	1
	101266	3/8 COOLANT HOSE x 36.00 (ISUZU RADIATOR)	1
NS	105352	DRAIN COCK	1

9.10 - Radiator Cold Front Group

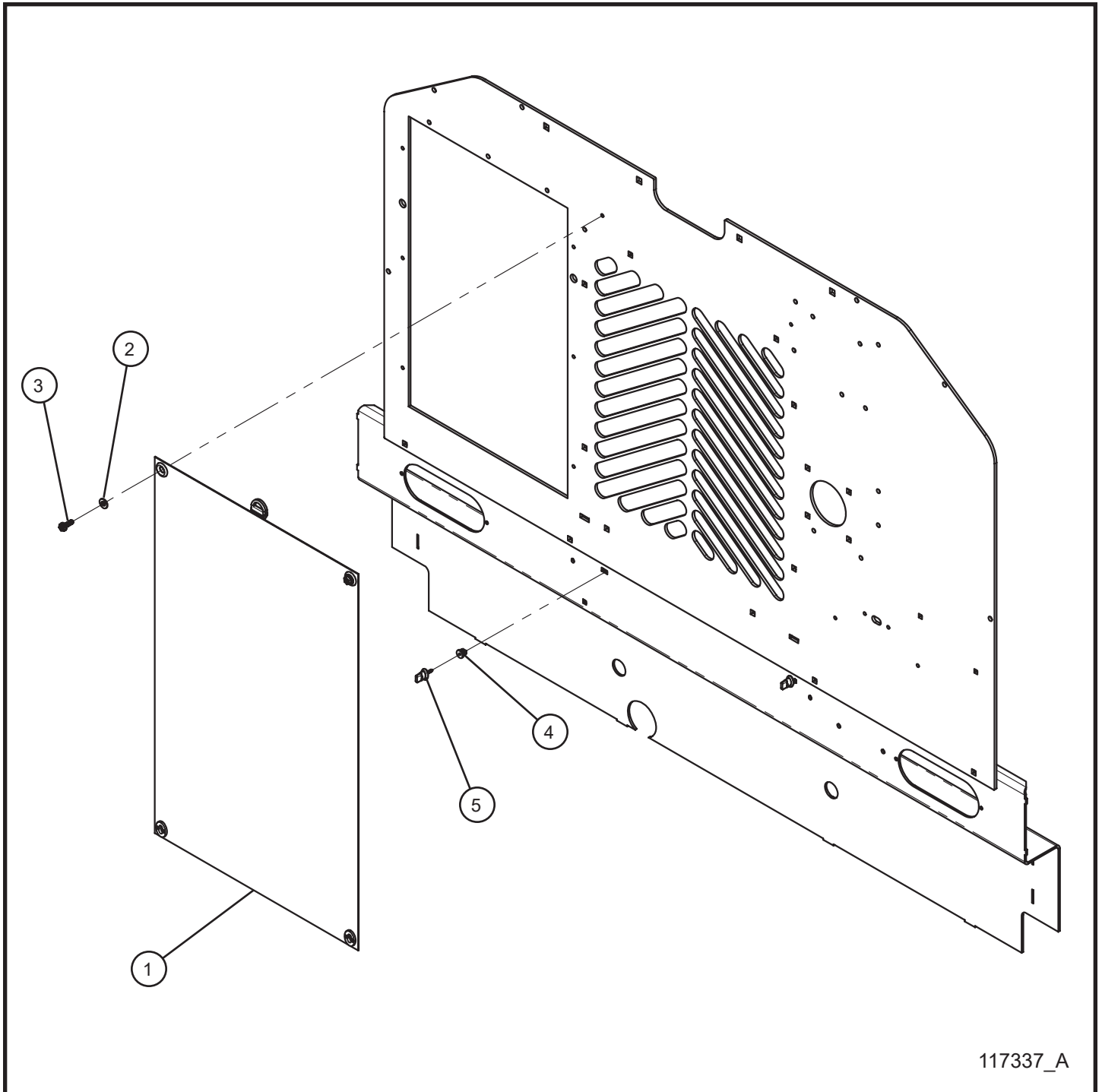

117337_A

9.10 - Radiator Cold Front Group

Item	Part No.	Part Description	Qty.
1	116156	MAXI-LITE UNIVERSAL COLD FRONT	1
2	047005	1/4 FLAT WASHER	2
3	041070	1/4-20 x 3/4 SL-HEX WASHER HEAD MACHINE SCREW	2
4	106052	NYLON NUT	2
5	106056	TURN BUTTON	2
NS	116155	MAXI-LITE UNIVERSAL COLD FRONT KIT	1

9.11 - Oil Drain Group

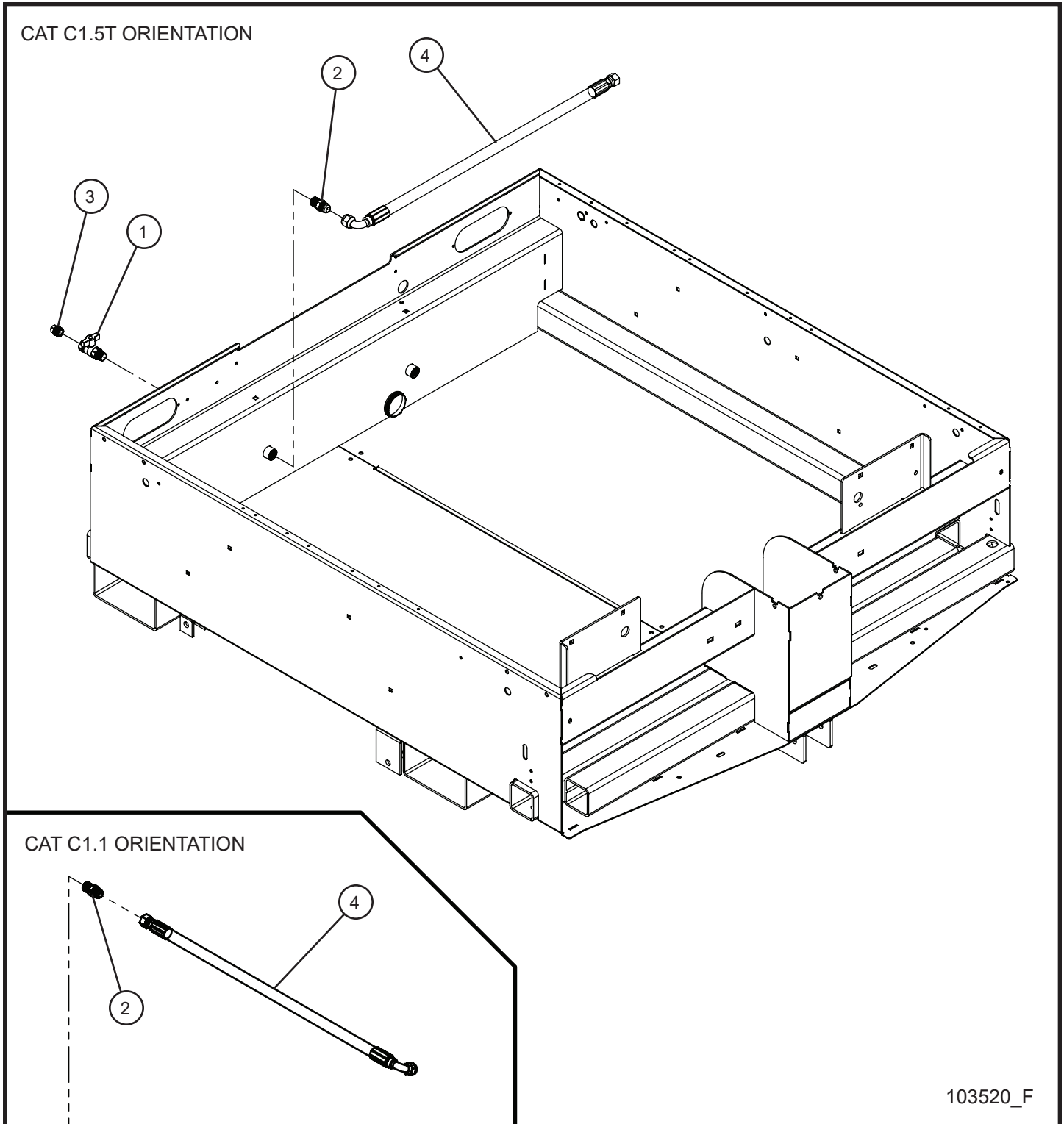

9.11 - Oil Drain Group

Item	Part No.	Part Description	Qty.
1	125254	BALL VALVE 1/2 NPT MALE X 1/2 NPT FEMALE	1
2	104131	MALE ADAPTER 1/2-20 NPT #10 JIC FLARE	1
3	026106	1/2 NPT SQUARE HEAD PLUG	1
4	103325	OIL DRAIN HOSE 10TOC-10FJX-BT-10FJX90-32.5	1

9.12 - Oil Drain Group Isuzu

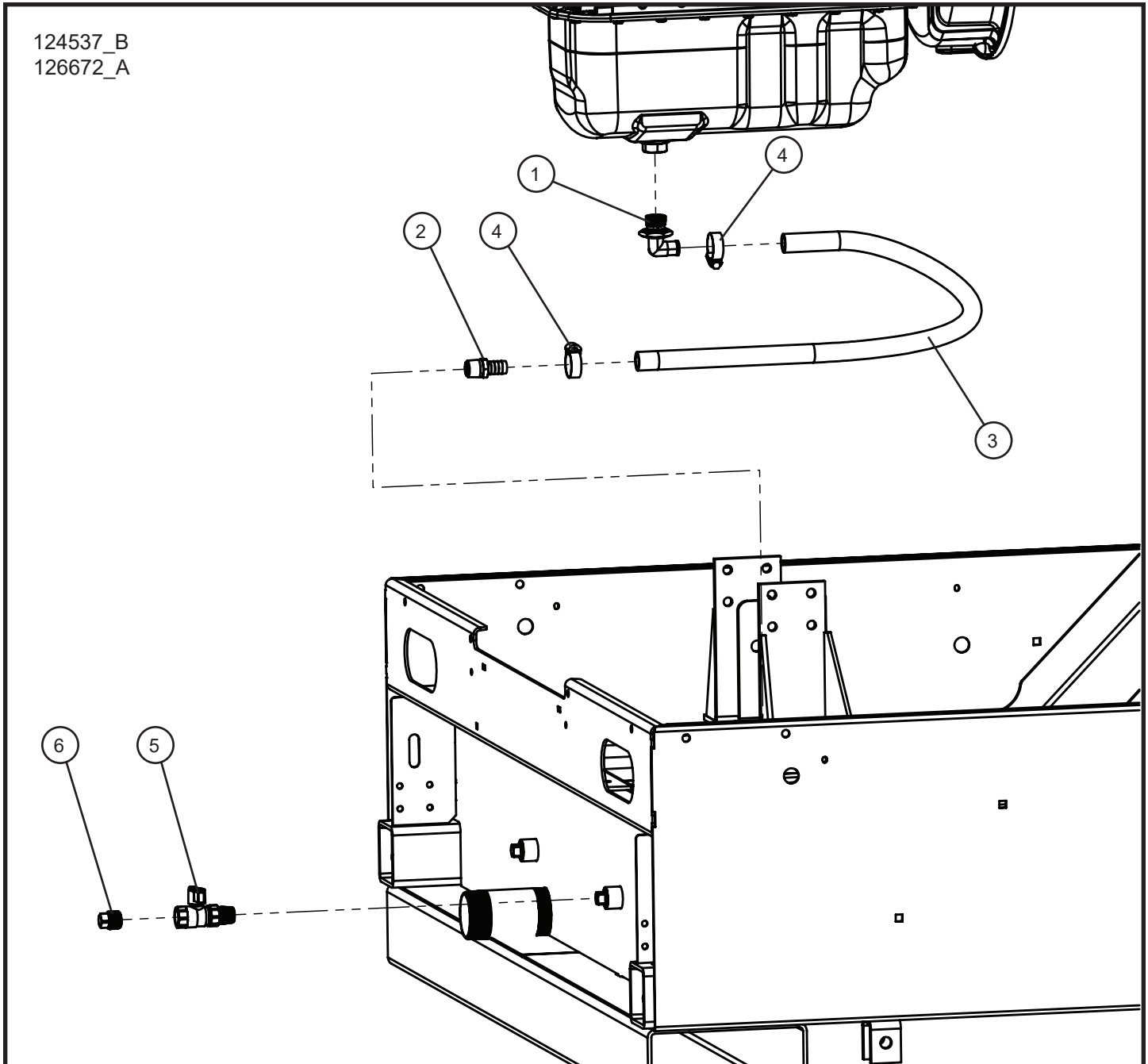

9.12 - Oil Drain Group Isuzu

Item	Part No.	Part Description	Qty.
1	123560	FITTING 90° ADAPTER M24X2 TO 5/8 IN HOSE BARB	1
2	123561	5/8 X 1/2 MNPT HOSE BARB	1
3	081040	5/8 PUSH-LOK X 32.00 INCHES	1
4	045032	#12 HOSE CLAMP	2
5	125254	BALL VALVE 1/2 NPT MALE X 1/2 NPT FEMALE	1
6	026106	PLUG 1/2 NPT SQUARE HEAD	1

NS - Not Shown

* * * - Contact Allmand for more information.

9.13 - Oil Drain Group Kubota

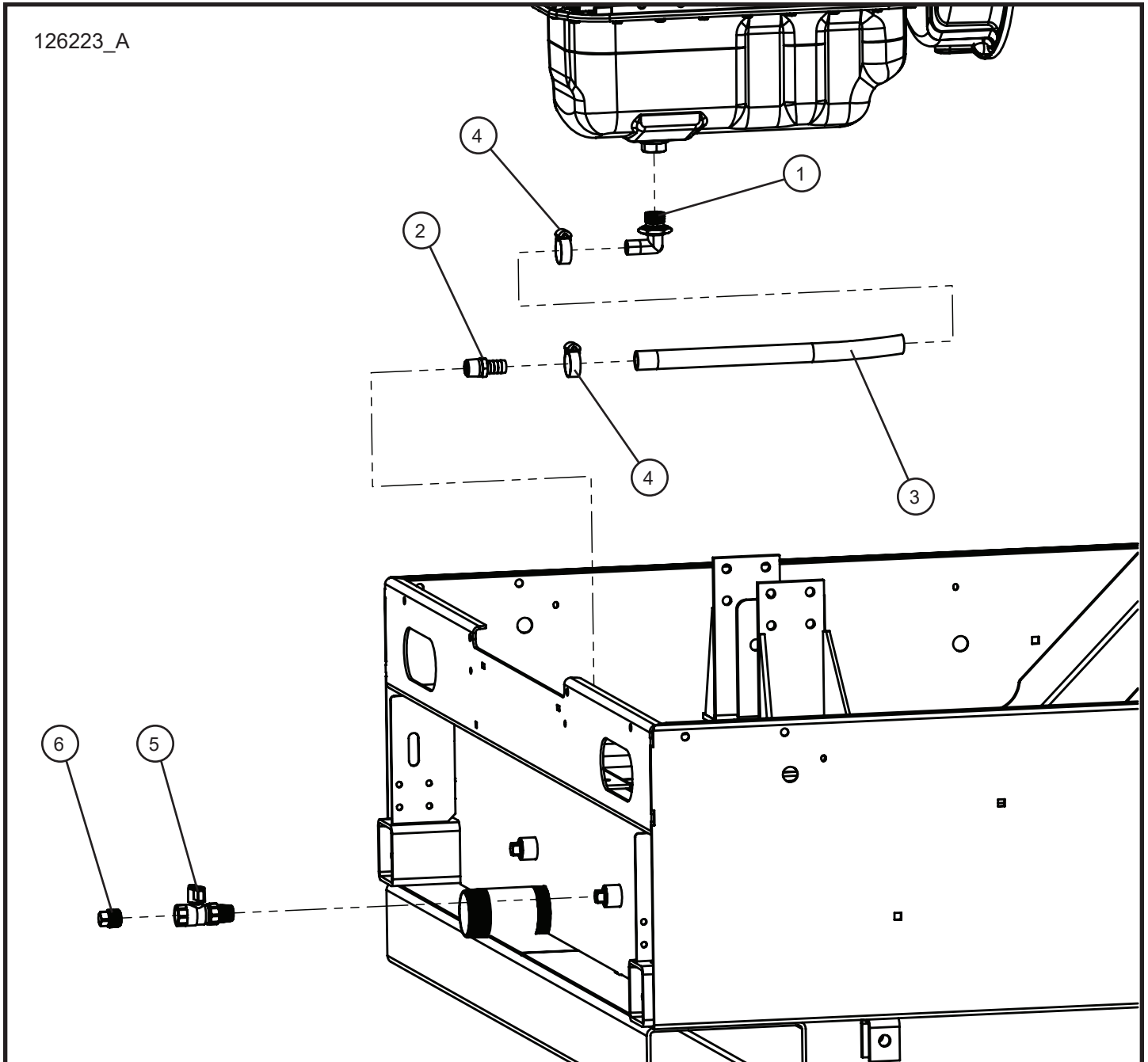

9.13 - Oil Drain Group Kubota

Item	Part No.	Part Description	Qty.
1	122048	FITTING 90° ADAPTER M22 x 1.5 TO 5/8 IN HOSE BARB	1
2	123561	5/8 X 1/2 MNPT HOSE BARB	1
3	081040	5/8 PUSH-LOK X 20.00 INCHES	1
4	045033	#10 HOSE CLAMP	2
5	125254	BALL VALVE 1/2 NPT MALE X 1/2 NPT FEMALE	1
6	026106	PLUG 1/2 NPT SQUARE HEAD	1

NS - Not Shown

* * * - Contact Allmand for more information.

9.14 - Webasto Thermo Top C Diesel Fired Block Heater

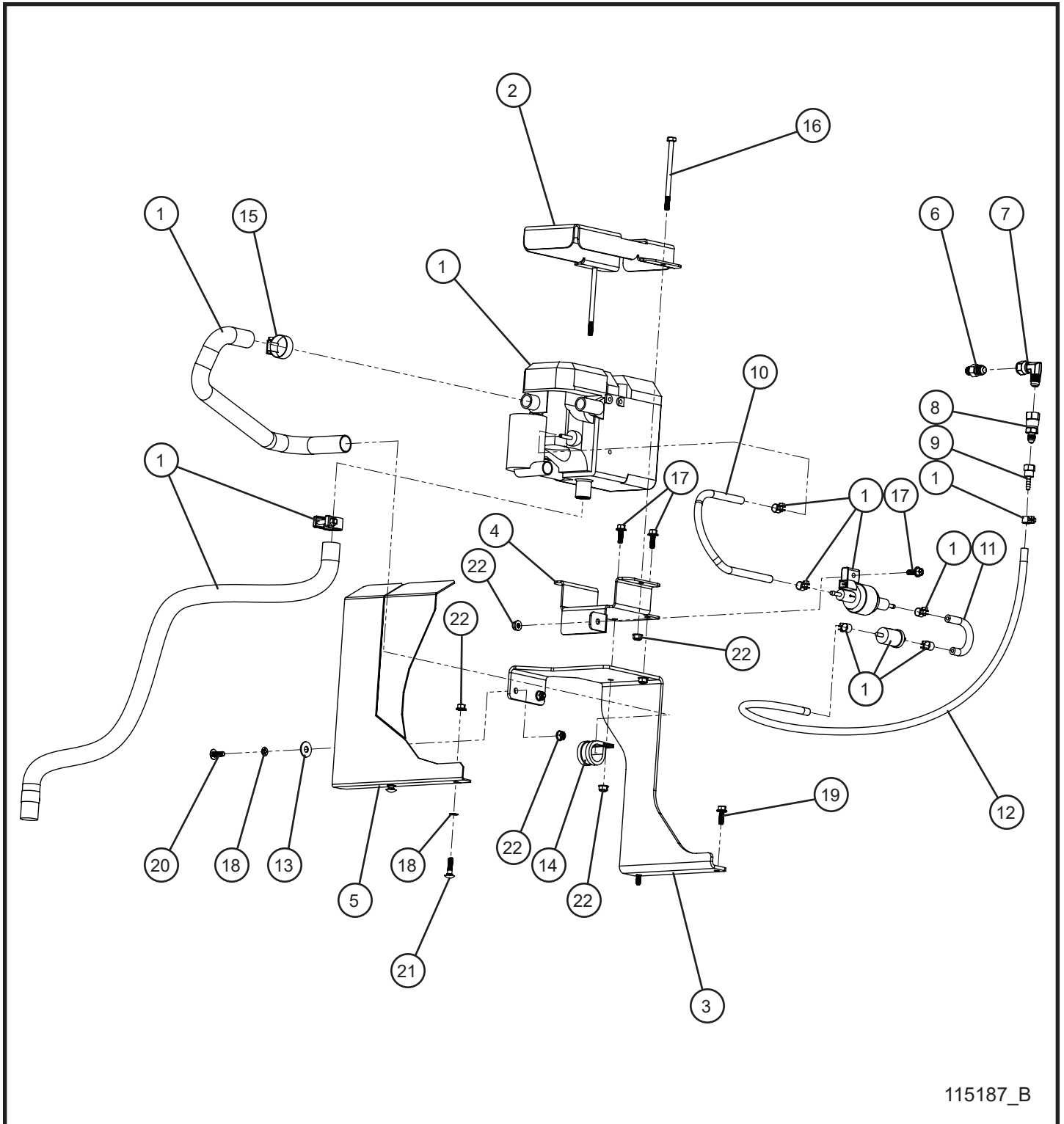

115187_B

9.14 - Webasto Thermo Top C Diesel Fired Block Heater

Item	Part No.	Part Description	Qty.
1	104946	WEBASTO TT C DIESEL FIRED COOLANT HEATER KIT	1
2	104949P	DIESEL BLOCK HEATER HOLD DOWN BRACKET	1
3	113628P	MAXI-LITE DIESEL BLOCK HEATER SUPPORT BRACKET	1
4	105033P	MAXI-LITE DIESEL BLOCK HEATER BOTTOM BRACKET	1
5	103609P	MAXI-LITE DIESEL BLOCK HEATER EXHAUST GUARD	1
	120597P	MAXI-LITE DIESEL BLOCK HEATER EXHAUST GUARD ISUZU	1
6	100655	1/2-20 x 6 JIC STRAIGHT CONNECTOR	1
7	101263	6 JIC 90° SWIVEL FITTING	1
8	105569	6 FJIC x 4 MJIC SWIVEL NUT ADAPTER	1
9	105568	4 JIC x 3/16 FITTING HOSE BARB	1
10	081001	HOSE 3/16" FUEL LINE x 14.0	1
11	081001	HOSE 3/16" FUEL LINE x 6.0	1
12	081001	HOSE 3/16" FUEL LINE x 36.0	1
13	047010	5/16 FLAT WASHER	2
14	022083	#16 CLAMP CUSH 3/8 HOLE	1
15	045032	#12 HOSE CLAMP	1
16	046039	1/4-20 x 4 HEX HEAD BOLT	2
17	056002	1/4-20 x 3/4 HEX SERRATED FLANGE SCREW	3
18	101701	1/4 PUSH NUT	4
19	041070	1/4-20 x 3/4 SL-HEX WASHER HEAD MACHINE SCREW	2
20	053006	1/4-20 x 3/4 CARRIAGE BOLT	2
21	100342	1/4-20 x 1 CARRIAGE BOLT	3
22	057001	1/4-20 HEX NYLOCK FLANGE NUT	10
NS	104254	RELAY 12V 40AMP	1
NS	106036	WIRE HARNESS ASSEMBLY DIESEL BLOCK HEATER	1
NS	116737	WIRE HARNESS ISUZU DFBH FUEL PUMP HARNESS	1
NS	117899	WIRING SCHEMATIC DFBH RELAY BLOCK ISUZU T4F DEEP SEA	1
NS	106045	WIRING SCHEMATIC DIESEL FIRED BLOCK HEATER	1

9.15 - Webasto Thermo Top EVO Diesel Fired Block Heater

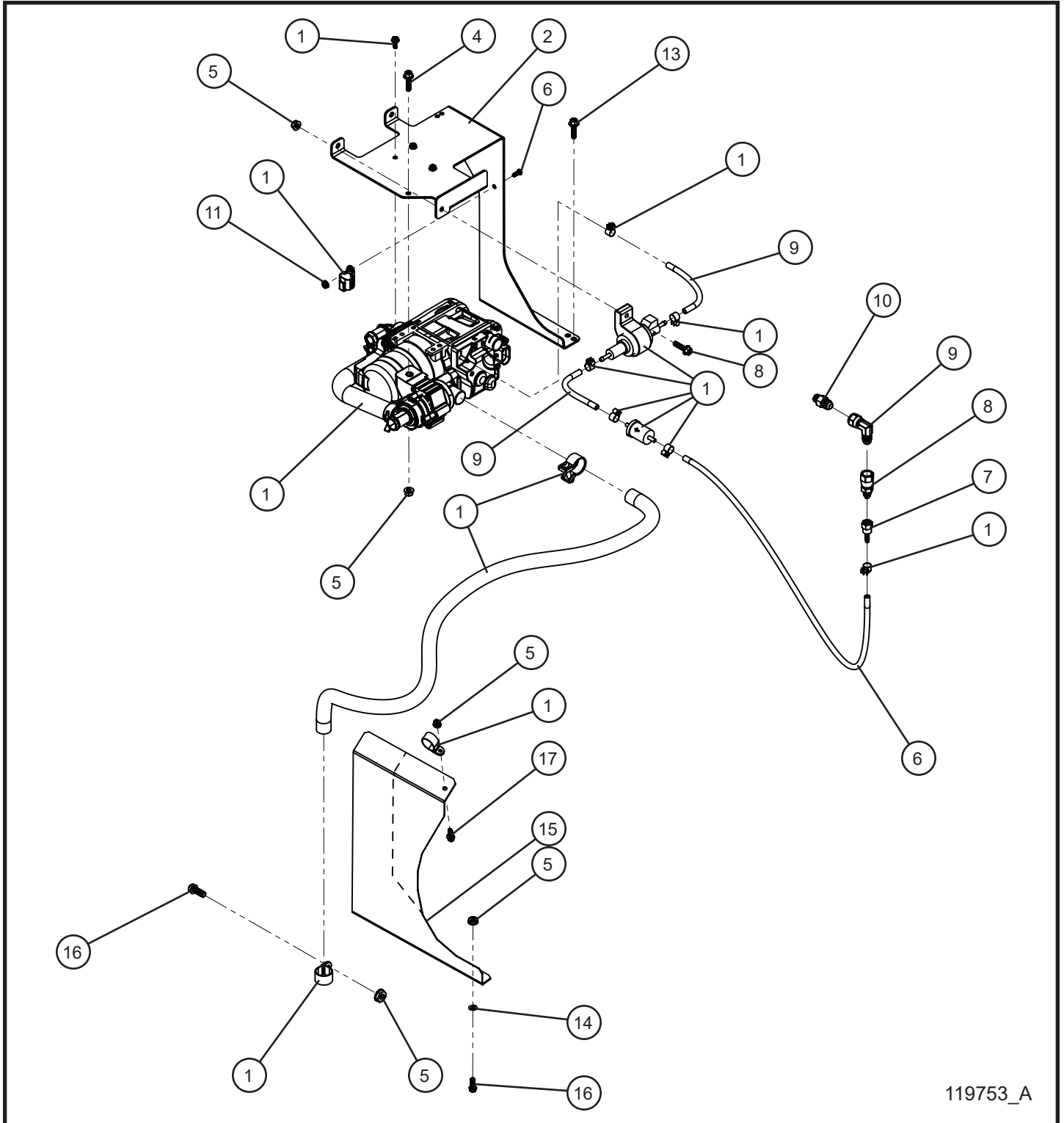

119753_A

9.15 - Webasto Thermo Top EVO Diesel Fired Block Heater

Item	Part No.	Part Description	Qty.
1	118278	WEBASTO TT EVO DIESEL FIRED COOLANT HEATER KIT	1
2	119754P	MAXI-LITE DIESEL BLOCK HEATER SUPPORT BRACKET	1
3	081001	HOSE 3/16" FUEL LINE x 6.0	2
4	056017	1/4-20 x 1 SERRATED FLANGE HEX BOLT	2
5	057001	1/4-20 HEX NYLOCK FLANGE NUT	6
6	081001	HOSE 3/16" FUEL LINE x 36.0	1
7	105568	4 JIC x 3/16 FITTING HOSE BARB	1
8	105569	6 FJIC x 4 MJIC SWIVEL NUT ADAPTER	1
9	101263	6 JIC 90° SWIVEL FITTING	1
10	100655	1/2-20 x 6 JIC STRAIGHT CONNECTOR	1
11	044016	#10-24 KEPS HEX NUT	1
12	041021	#10-24 x 1/2 PH-ROUND HEAD	1
13	041070	1/4-20 x 3/4 SL-HEX WASHER HEAD MACHINE SCREW	2
14	101701	1/4 PUSH NUT	4
15	103609P	MAXI-LITE DIESEL BLOCK HEATER EXHAUST GUARD	1
	120597P	MAXI-LITE DIESEL BLOCK HEATER EXHAUST GUARD ISUZU	1
16	100342	1/4-20 x 1 CARRIAGE BOLT	3
17	056019	1/4-20 X 3/4 HEX FLANGE SCREW	1
NS	116737	WIRE HARNESS ISUZU DFBH FUEL PUMP HARNESS	1
NS	117899	WIRING SCHEMATIC DFBH RELAY BLOCK ISUZU T4F DEEP SEA	1
NS	119912	WIRING SCHEMATIC DIESEL FIRED BLOCK HEATER	1

10.1 - CAT C1.1 Engine Assembly Group (1 of 6)

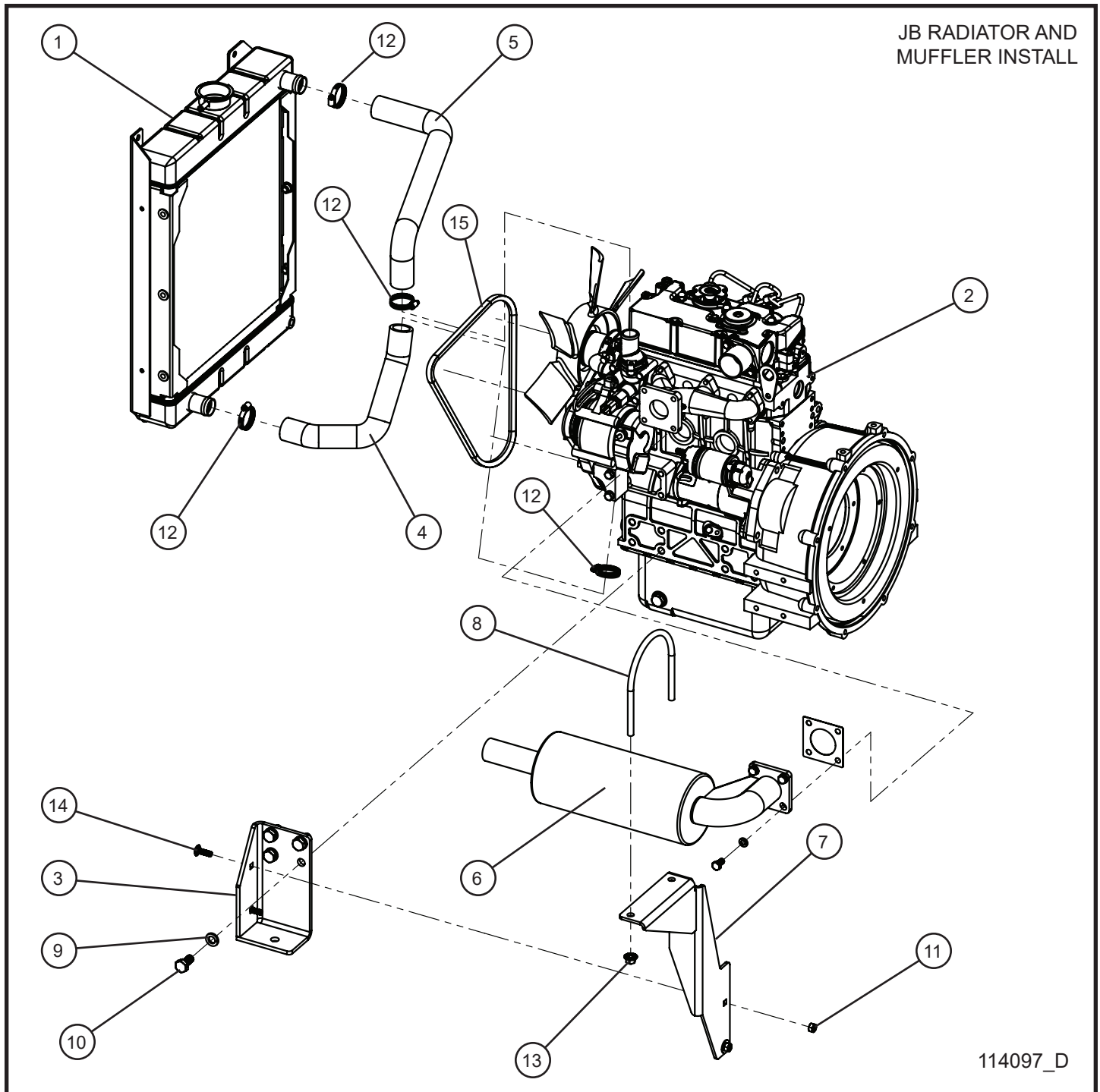

114097_D

10.1 - CAT C1.1 Engine Assembly Group (1 of 6)

Item	Part No.	Part Description	Qty.
1	105393	JB RADIATOR SMALL ENGINES 1.0L / 1.1L	1
2	112561	CAT C1.1 ENGINE	1
3	108889P	ENGINE BRACKET LEFT WELDMENT	1
4	113828	CAT C1.1 LOWER RADIATOR HOSE	1
5	113827	CAT C1.1 UPPER RADIATOR HOSE	1
6	104787	CAT C1.1 MUFFLER 4.5 SPOUT	1
7	112309P	MUFFLER BRACKET WELDMENT	1
8	105744	4.75" MUFFLER U-BOLT	1
9	043085	1/2 SPLITLOCK WASHER	4
10	042300	M12 x 25mm x 1.25mm HEX HEAD BOLT	4
11	057008	5/16-18 HEX NYLOCK FLANGE NUT	2
12	045034	#16 HOSE CLAMP	4
13	044029	3/8-16 SERRATED FLANGE NUT	2
14	053020	5/16-18 x 1 CARRIAGE BOLT	2
15	125224	V-BELT GATES REPLACEMENT CAT/PERKINS 1.1L	1
NS	110113	CAT C1.1 ENGINE HARNESS	1
NS	113494	CAT C1.1 40AMP CHARGE CIRCUIT FUSE	1
NS	106309	JCASE 40A LITTLE FUSE	1
NS	110112	CAT 1.1L SCHEMATIC	1

10.1 - CAT C1.1 Engine Assembly Group (2 of 6)

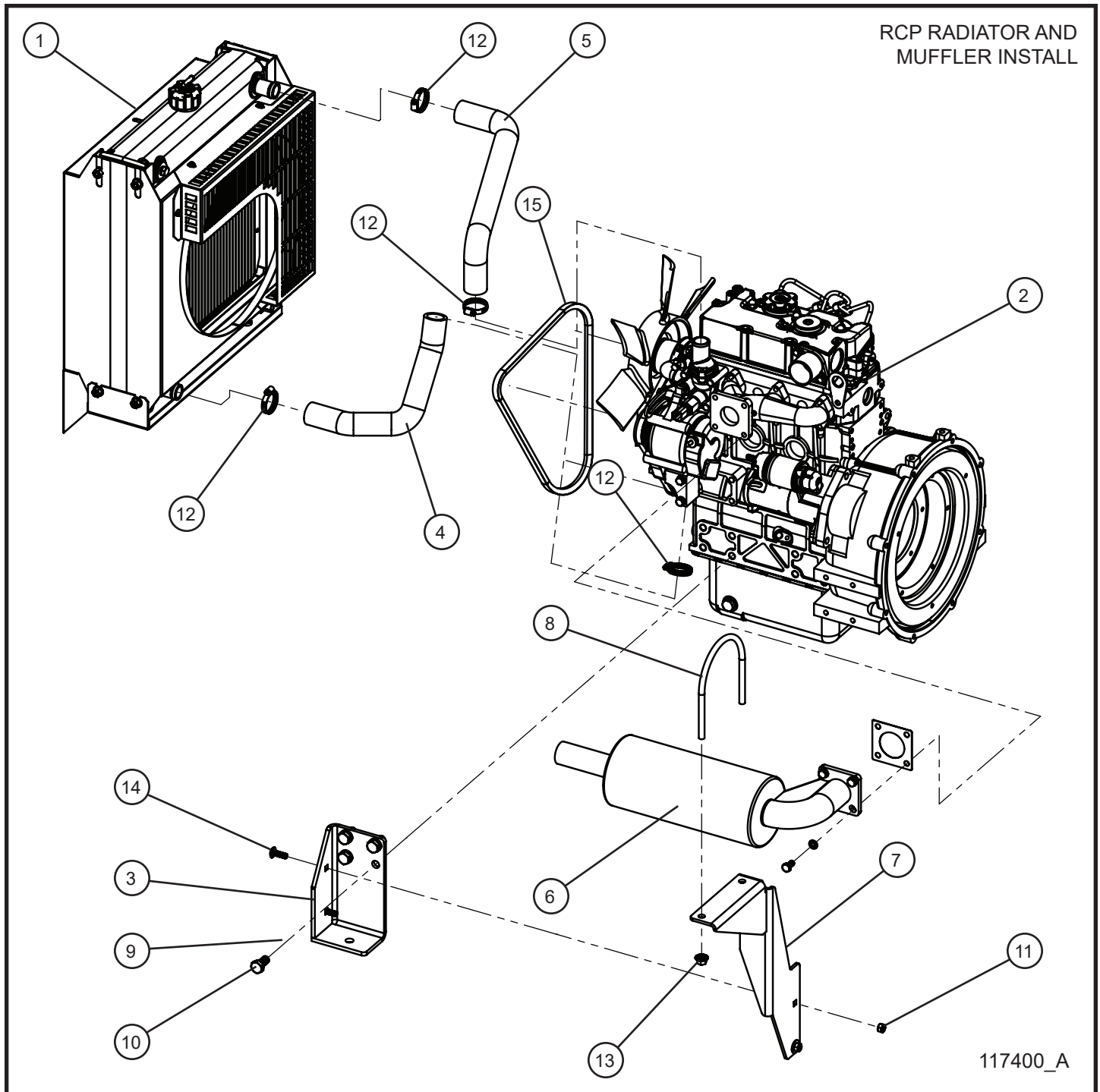

10.1 - CAT C1.1 Engine Assembly Group (2 of 6)

Item	Part No.	Part Description	Qty.
1	103422	RCP RADIATOR	1
2	112561	CAT C1.1 ENGINE	1
3	108889P	ENGINE BRACKET LEFT WELDMENT	1
4	113828	CAT C1.1 LOWER RADIATOR HOSE	1
5	113827	CAT C1.1 UPPER RADIATOR HOSE	1
6	104787	CAT C1.1 MUFFLER 4.5 SPOUT	1
7	112309P	MUFFLER BRACKET WELDMENT	1
8	105744	4.75" MUFFLER U-BOLT	1
9	043085	1/2 SPLITLOCK WASHER	4
10	042300	M12 x 25mm x 1.25mm HEX HEAD BOLT	4
11	057008	5/16-18 HEX NYLOCK FLANGE NUT	2
12	045034	#16 HOSE CLAMP	4
13	044029	3/8-16 SERRATED FLANGE NUT	2
14	053020	5/16-18 x 1 CARRIAGE BOLT	2
15	125224	V-BELT GATES REPLACEMENT CAT/PERKINS 1.1L	1
NS	102911	RCP RADIATOR KIT	1
NS	110113	CAT C1.1 ENGINE HARNESS	1
NS	113494	CAT C1.1 40AMP CHARGE CIRCUIT FUSE	1
NS	106309	JCASE 40A LITTLE FUSE	1
NS	110112	CAT 1.1L SCHEMATIC	1

10.1 - CAT C1.1 Engine Assembly Group (3 of 6)

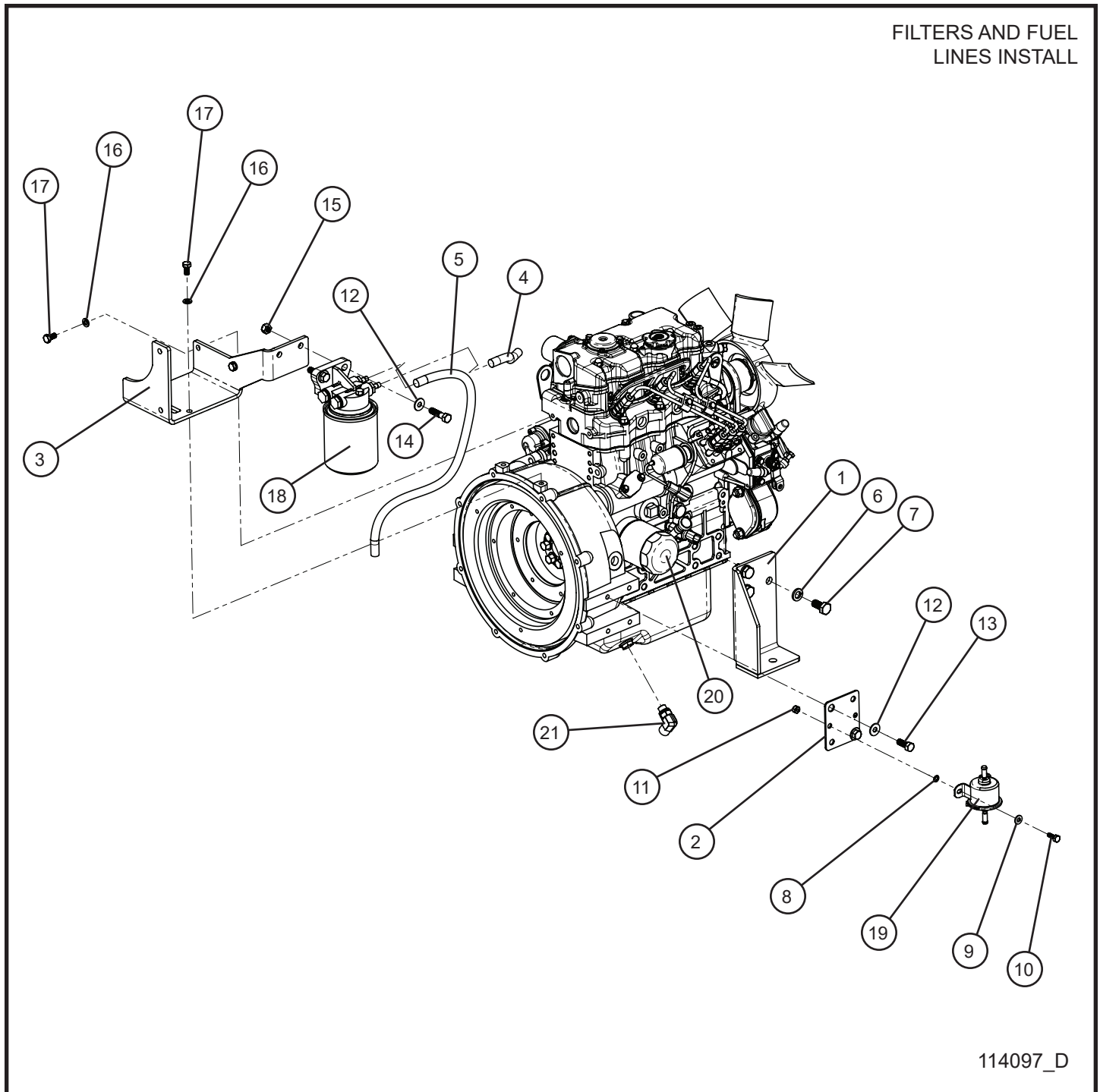

114097_D

10.1 - CAT C1.1 Engine Assembly Group (3 of 6)

Item	Part No.	Part Description	Qty.
1	108891P	ENGINE BRACKET RIGHT WELDMENT	1
2	105402P	FUEL PUMP MOUNT PLATE	1
3	113327P	CAT 1.1L AIR CLEANER MOUNT	1
4	081018	HOSE 5/16" FUEL LINE x 7.0	1
5	081018	HOSE 5/16" FUEL LINE x 20.0	1
6	043085	1/2 SPLITLOCK WASHER	3
7	042300	M12 x 25mm x 1.25mm HEX HEAD BOLT	3
8	043050	1/4 INTL TOOTH LOCK WASHER	1
9	047005	1/4 FLAT WASHER	2
10	102573	1/4-20 x 3/4 HEX HEAD BOLT	2
11	044023	1/4-20 NYLOCK HEX NUT	2
12	047010	5/16 FLAT WASHER	13
13	046110	3/8-16 x 1 HEX HEAD BOLT	3
14	046120	3/8-16 x 1 1/2 HEX HEAD BOLT	2
15	044038	3/8-16 NYLOCK HEX NUT PL	2
16	043055	5/16 SPLITLOCK WASHER	5
17	042027	M8 x 16mm x 1.25mm HEX HEAD BOLT	4
18	112464	CAT 1.1L FUEL FILTER	1
19	114114	CAT 1.1L FUEL PUMP	1
20	113635	CAT 1.1L OIL FILTER	1
21	108981	10JIC X 16mm HYDRAULIC 90° FITTING	1
NS	120240	CAT C1.1 FILTER KIT	1
NS	433400	#4 HOSE CLAMP	4

10.1 - CAT C1.1 Engine Assembly Group (4 of 6)

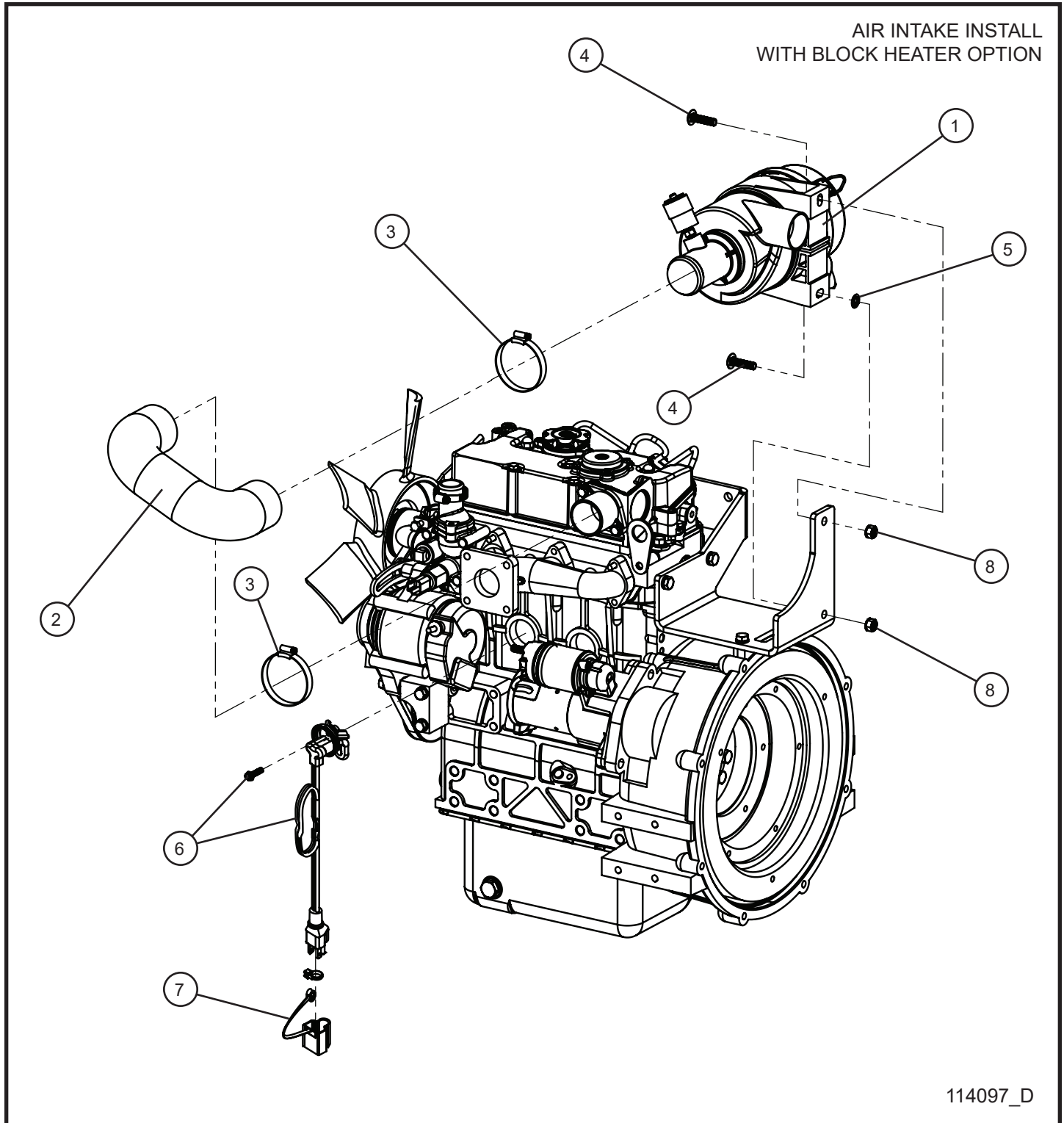

114097_D

10.1 - CAT C1.1 Engine Assembly Group (4 of 6)

Item	Part No.	Part Description	Qty.
1	111568	AIR CLEANER ASSEMBLY STRAIGHT INLET	1
	650290	AIR FILTER	1
	104795	AIR FILTER SERVICE INDICATOR KIT	1
2	113332	AIR INTAKE HOSE SMALL ENGINE	1
3	045038	#32 HOSE CLAMP	2
4	053022	5/16-18 x 1 1/4 CARRIAGE BOLT	2
5	045217	5/16 PUSH NUT	1
6	651192	BLOCK HEATER CAT C1.1	1
7	105995	END COVER 120 VOLT CORD	1
8	044031	5/16-18 KEPS HEX NUT PL	2

10.1 - CAT C1.1 Engine Assembly Group (5 of 6)

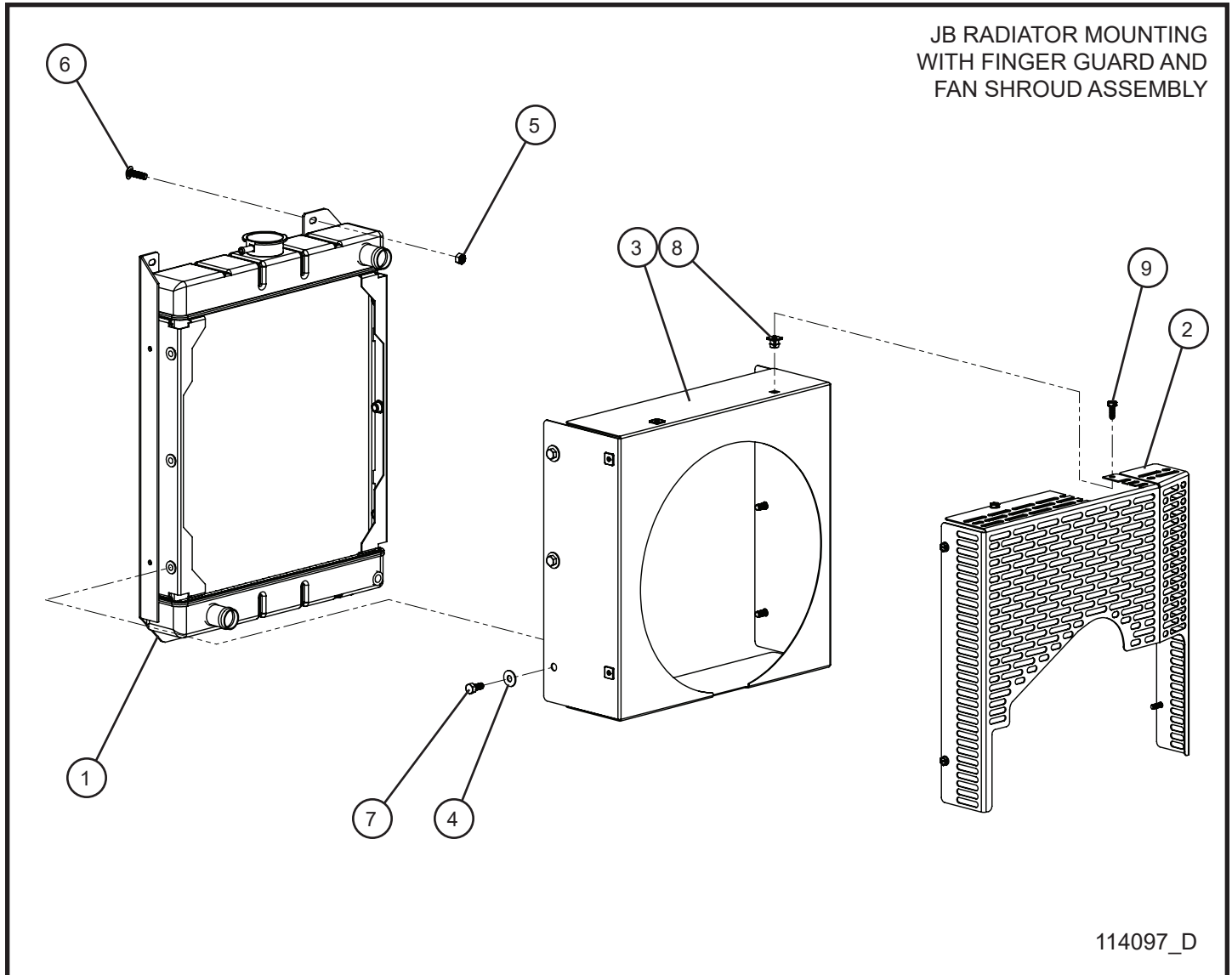

10.1 - CAT C1.1 Engine Assembly Group (5 of 6)

Item	Part No.	Part Description	Qty.
1	105393	JB RADIATOR SMALL ENGINES 1.0L / 1.1L	1
2	108862P	CAT 1.1L FINGER GUARD	1
3	113825P	CAT 1.1L FAN SHROUD	1
4	047010	5/16 FLAT WASHER PL	6
5	044033	5/16-18 NYLOCK HEX NUT PL	4
6	053020	5/16-18 x 1 CARRIAGE BOLT PL	4
7	046045	5/16-18 x 3/4 HEX HEAD CS GR5 PL	6
8	105408	GROMMET DOUBLE SPLIT NUT	6
9	041070	1/4-20 x 3/4 SL-HEX WASHER HEAD MS TP F	6

10.1 - CAT C1.1 Engine Assembly Group (6 of 6)

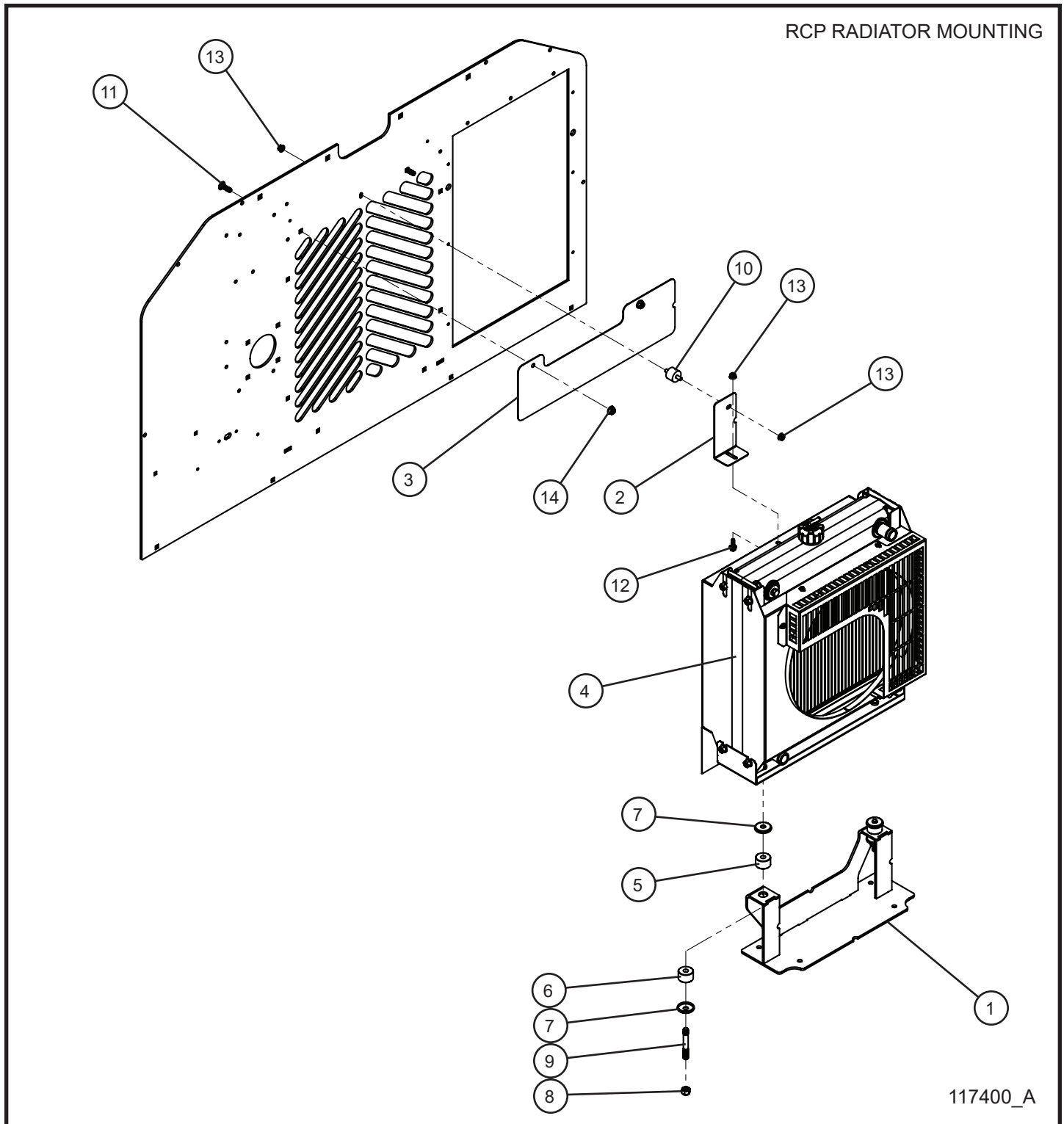

10.1 - CAT C1.1 Engine Assembly Group (6 of 6)

Item	Part No.	Part Description	Qty.
1	117395P	MAXI-LITE CAT C1.1 RCP RADIATOR MOUNT WELDMENT	1
2	117396P	MAXI-LITE CAT C1.1 RCP RADIATOR SHROUD ANGLE BRACKET	1
3	117397P	MAXI-LITE CAT C1.1 RCP RADIATOR PLATE FILLER	1
4	103422	RCP RADIATOR	1
5	116086	RCP RADIATOR RAISED RUBBER ISOLATOR	2
6	116085	RCP RADIATOR RUBBER ISOLATOR	2
7	116087	RCP RADIATOR CUP WASHER	4
8	044129	M10 x 1.5mm NYLOCK NUT	2
9	103425	M10 x 1.5mm STUD BOLT	2
10	330057	BOX MOUNT	1
11	053020	5/16-18 x 1 CARRIAGE BOLT	2
12	056002	1/4-20 x 3/4 HEX SERRATED FLANGE SCREW	1
13	057001	1/4-20 HEX NYLOCK FLANGE NUT	3
14	057008	5/16-18 HEX NYLOCK FLANGE NUT	6
NS	102911	RCP RADIATOR KIT	1

10.2 - CAT C1.1 Engine Fuel Lines

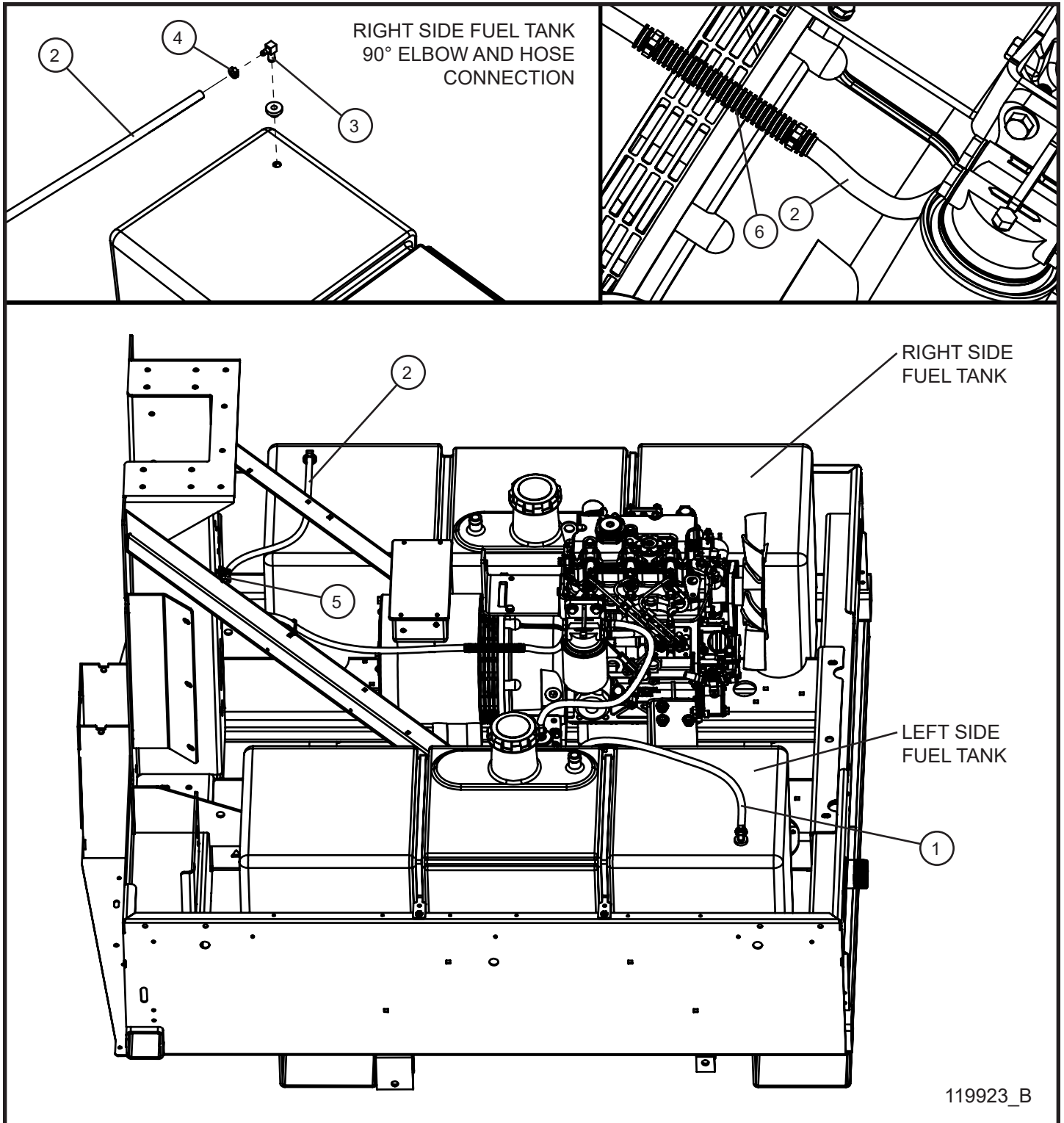

10.2 - CAT C1.1 Engine Fuel Lines

Item	Part No.	Part Description	Qty.
1	081018	HOSE 5/16 FUEL LINE x 35.00	1
2	081016	HOSE 1/4 FUEL LINE X 70.00	1
3	105106	DAPCO 90° ELBOW	1
4	433400	#4 HOSE CLAMP	4
5	022018	#8 CUSH CLAMP	1
	053020	5/16-18 X 1 CARRIAGE BOLT	1
	057006	5/16-18 SERRATED FLANGE NUT	1
6	022205	1/2" SPLIT LOOM X 5.00	1

10.3 - CAT C1.1 Webasto Thermo Top C Heater Lines

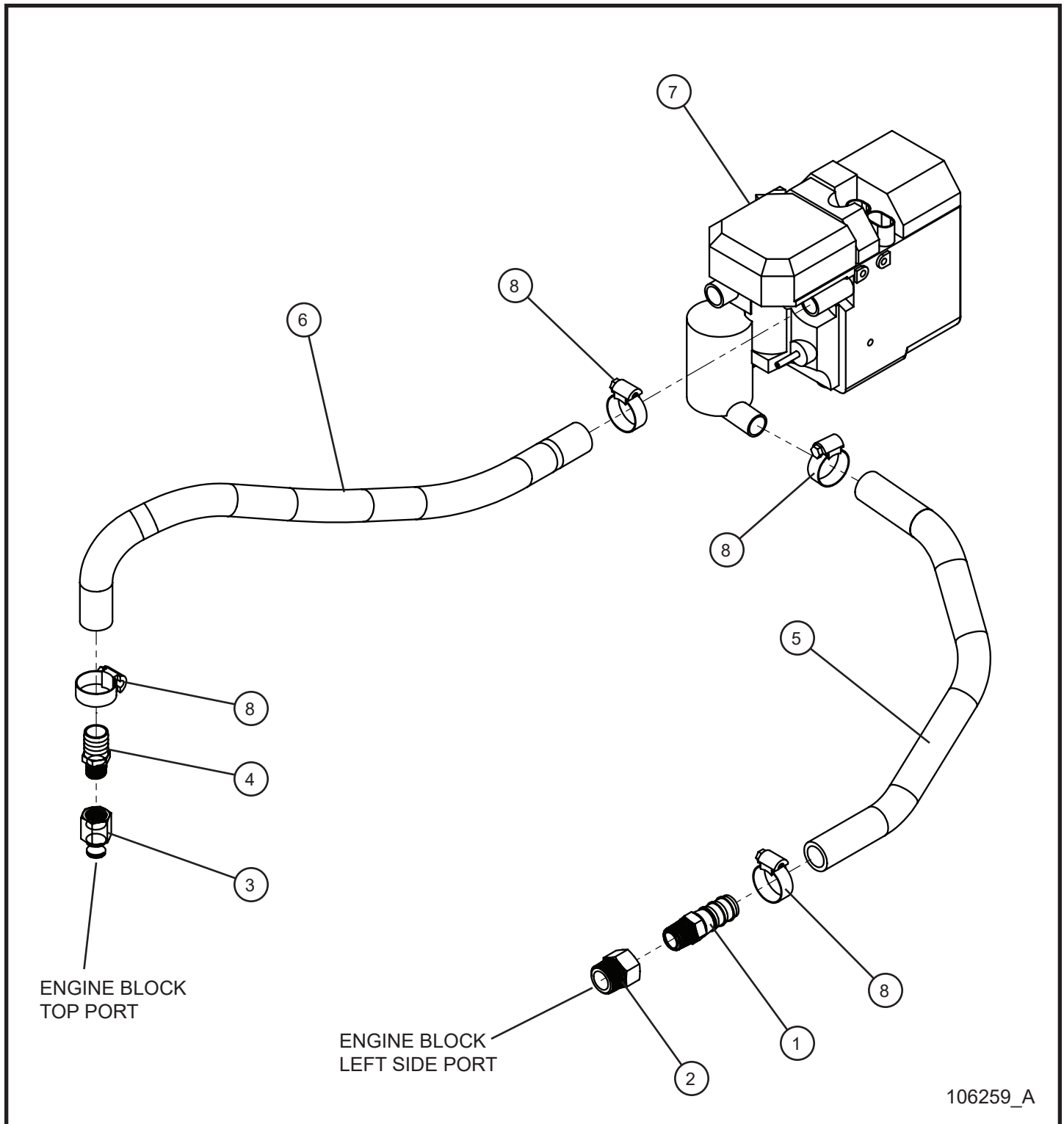

10.3 - CAT C1.1 Webasto Thermo Top C Heater Lines

Item	Part No.	Part Description	Qty.
1	104954	BARB ADAPTOR 1/2 NPT MALE x 3/4 HOSE	1
2	104955	1/2 NPT FEMALE x 3/4 BSPT MALE ADAPTOR ZINC PL STEEL	1
3	104798	FITTING ADAPTOR 3/8" BSPT TO 3/8" NPT	1
4	104683	FITTING HOSE BARB 3/8" NPT - 3/4" BARB	1
5	105016	3/4" HEATER HOSE x 18.0	1
6	105016	3/4" HEATER HOSE x 25.0	1
7	104946	WEBASTO TT C DIESEL FIRED COOLANT HEATER KIT	1
8	045032	#12 HOSE CLAMP	4

10.4 - CAT C1.1 Webasto Thermo Top EVO Heater Lines

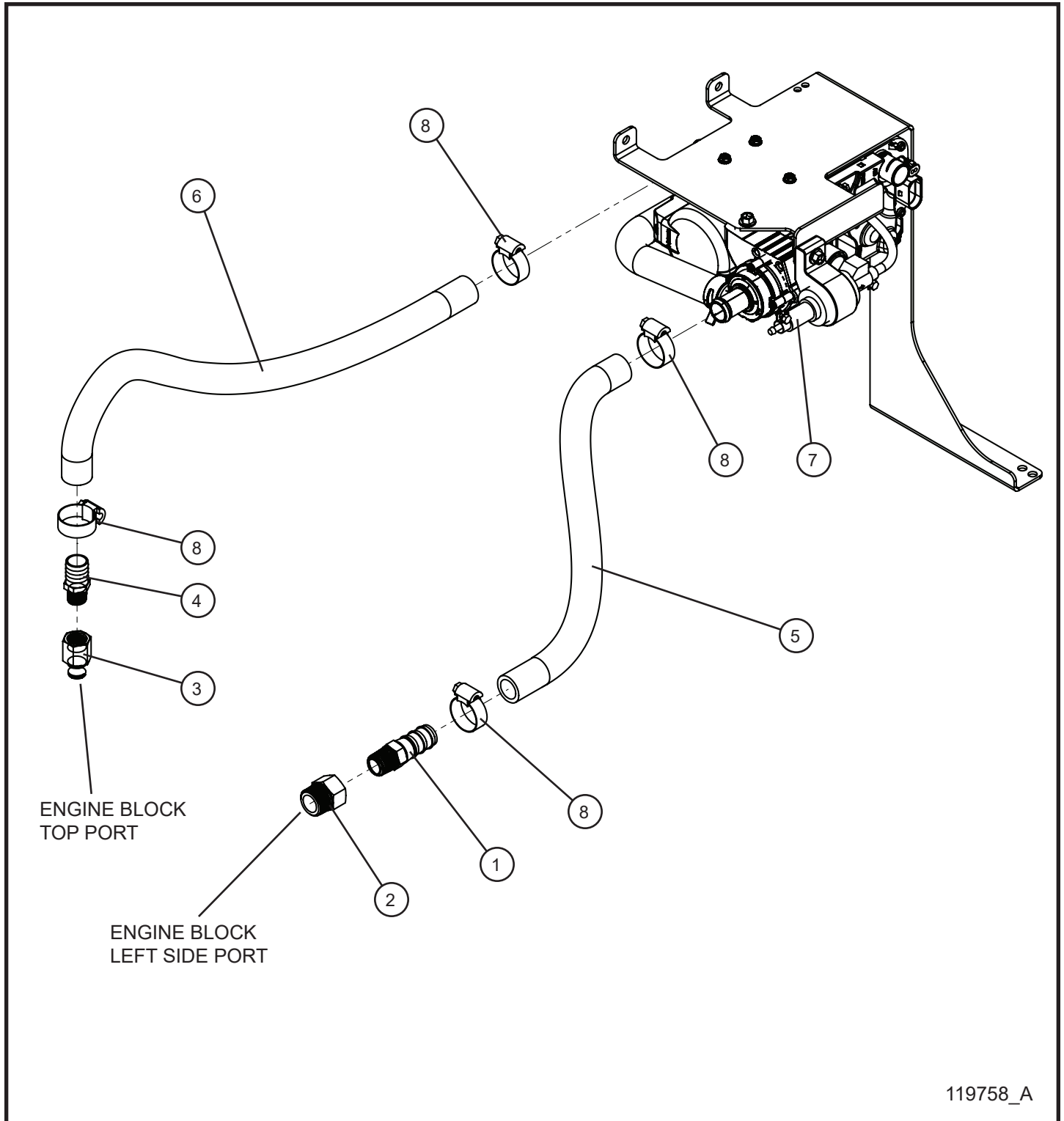

119758_A

10.4 - CAT C1.1 Webasto Thermo Top EVO Heater Lines

Item	Part No.	Part Description	Qty.
1	104954	BARB ADAPTOR 1/2 NPT MALE x 3/4 HOSE	1
2	104955	1/2 NPT FEMALE x 3/4 BSPT MALE ADAPTOR ZINC PL STEEL	1
3	104798	FITTING ADAPTOR 3/8" BSPT TO 3/8" NPT	1
4	104683	FITTING HOSE BARB 3/8" NPT - 3/4" BARB	1
5	105016	3/4" HEATER HOSE x 15.0	1
6	105016	3/4" HEATER HOSE x 31.0	1
7	118278	WEBASTO TT EVO DIESEL FIRED COOLANT HEATER KIT	1
8	045032	#12 HOSE CLAMP	4

10.5 - CAT C1.1 Engine Shocker Group (1 of 2)

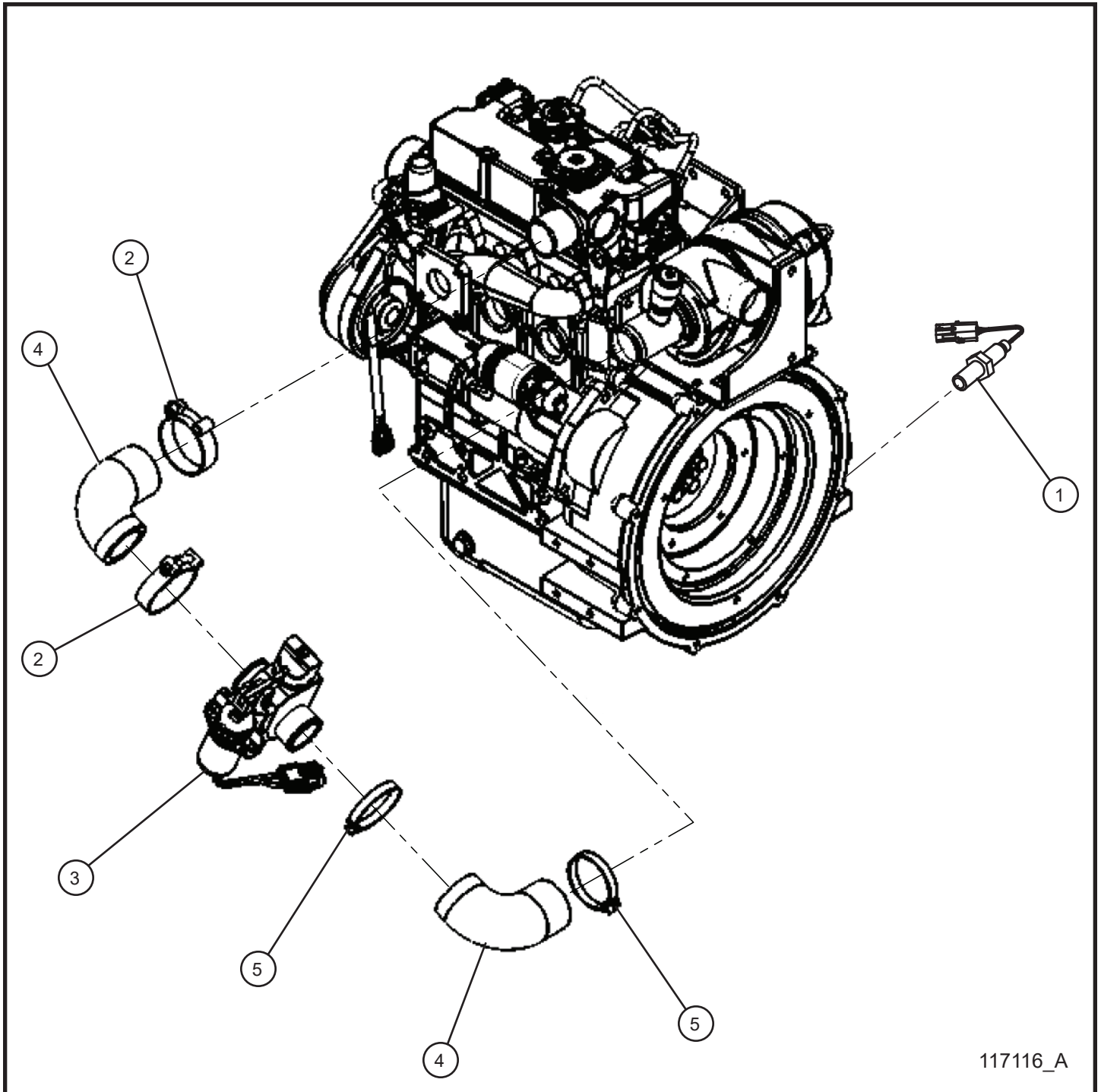

117116_A

10.5 - CAT C1.1 Engine Shocker Group (1 of 2)

Item	Part No.	Part Description	Qty.
1	105536	RPM SENSOR 18mm x 1.5	1
2	105649	2 INCH STAINLESS STEEL T-BOLT CLAMP	2
3	117302	SHOCKER 1750 VALVE DELPHI CONNECTOR	1
4	113332	AIR INTAKE HOSE SMALL ENGINE	1
5	045038	#32 HOSE CLAMP	2
NS	117303	SHOCKER 1750 VALVE KIT	1
NS	105802	HARNESS SHOCKER VALVE	1
NS	105702	SHOCKER SETUP INSTRUCTIONS	1
NS	106156	SCHEMATIC SHOCKER VALVE HARNESS	1

10.5 - CAT C1.1 Engine Shocker Group (2 of 2)

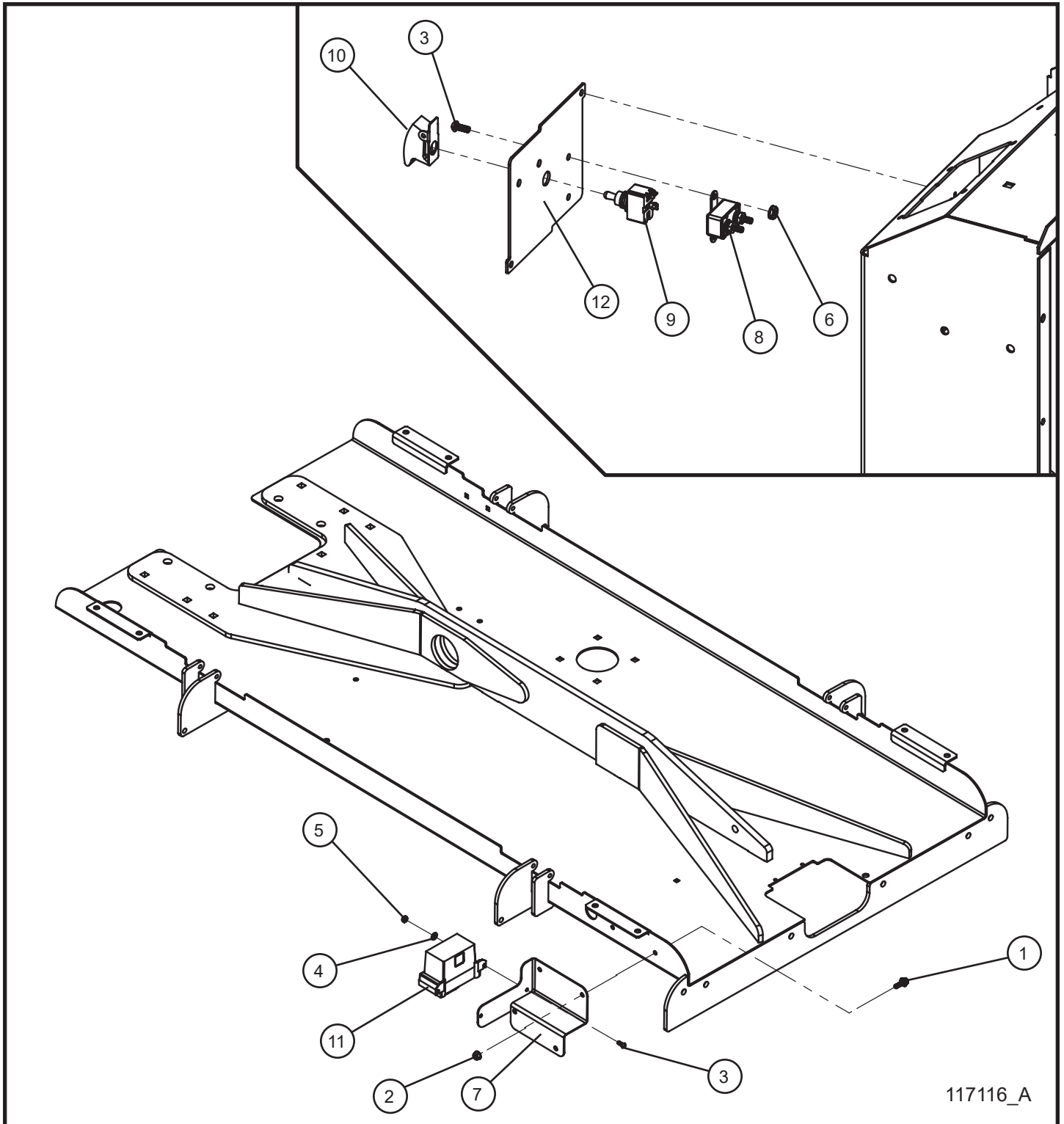

10.5 - CAT C1.1 Engine Shocker Group (2 of 2)

Item	Part No.	Part Description	Qty.
1	056002	1/4-20 x 3/4 HEX SERRATED FLANGE SCREW	2
2	057001	1/4-20 HEX NYLOCK FLANGE NUT	2
3	041021	#10-24 x 1/2 PH-ROUND HEAD MACHINE SCREW	4
4	047070	#10 FLAT WASHER	2
5	044018	#10-24 NYLOCK HEX NUT	2
6	044016	#10-24 KEPS HEX NUT	2
7	113476P	MAXI-LITE SHOCKER CONTROLLER BRACKET	1
8	105636	20 AMP BREAKER	1
9	340009	15A 125V ON/OFF TOGGLE SWITCH	1
10	105645	CONTROLLER PASS TOGGLE SWITCH GUARD	1
11	105692	R5 SHOCKER CONTROLLER	1
12	111228P	MAXI-LITE COMPONENT BOX BACK COVER	1
NS	117303	SHOCKER 1750 VALVE KIT	1
NS	105802	SHOCKER VALVE HARNESS	1
NS	105702	SHOCKER SETUP INSTRUCTIONS	1
NS	106156	SHOCKER VALVE HARNESS SCHEMATIC	1

10.6 - CAT C1.1 Engine PacBrake Group

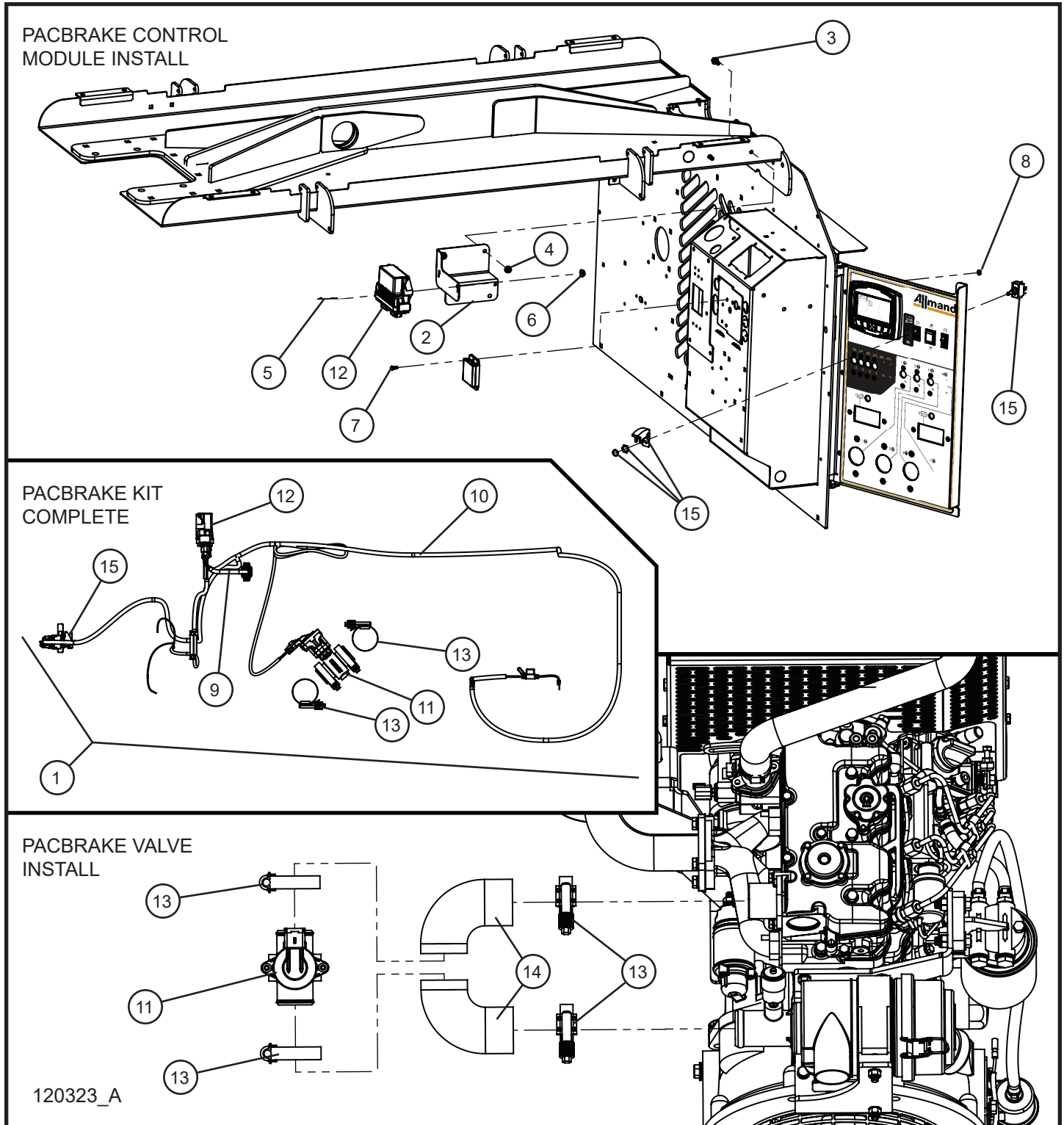

10.6 - CAT C1.1 Engine PacBrake Group

Item	Part No.	Part Description	Qty.
1	118631	PACBRAKE 1.75" AIR INTAKE VALVE KIT COMPLETE MAXI-LITE	1
2	113476P	MAXI-LITE SHOCKER CONTROLLER BRACKET	1
3	056002	1/4-20 X 3/4 HEX SERRATED FLANGE SCREW	2
4	057001	1/4-20 HEX NYLOCK FLANGE NUT	2
5	056012	1/4-20 x 1 1/2 SERRATED FLANGE HEX HEAD SCREW	2
6	057000	1/4-20 HEX SERRATED FLANGE NUT	2
7	041012	#8-32 X 1/2 PL SCREW MS	2
8	044003	#8-32 NC KEPS NUT	2
9	122731	PACBRAKE AC FREQUENCY WIRE HARNESS MAXI-LITE	1
10	122732	PACBRAKE DC WIRE HARNESS MAXI-LITE	1
11	122735	PACBRAKE 1.75" AIR INTAKE VALVE	1
12	122736	PACBRAKE AIR INTAKE VALVE CONTROL MODULE	1
13	122737	PACBRAKE SAE 262 BAND CLAMP	4
14	113332	AIR INTAKE HOSE SMALL ENGINE	1
15	122739	PACBRAKE TOGGLE SWITCH KIT	1
NS	103864	FUSE HOLDER INLINE BLADE	1
NS	104990	FUSE BLADE 2 AMP ATO/ATC	1
NS	105844	15 AMP MINI FUSE	1
NS	117814	WIRE SCHEMATIC PACBRAKE AIR VALVE	1

NS - Not Shown

* * * - Contact Allmand for more information.

10.7 - CAT C1.1 Vertical Exhaust Pipe Option

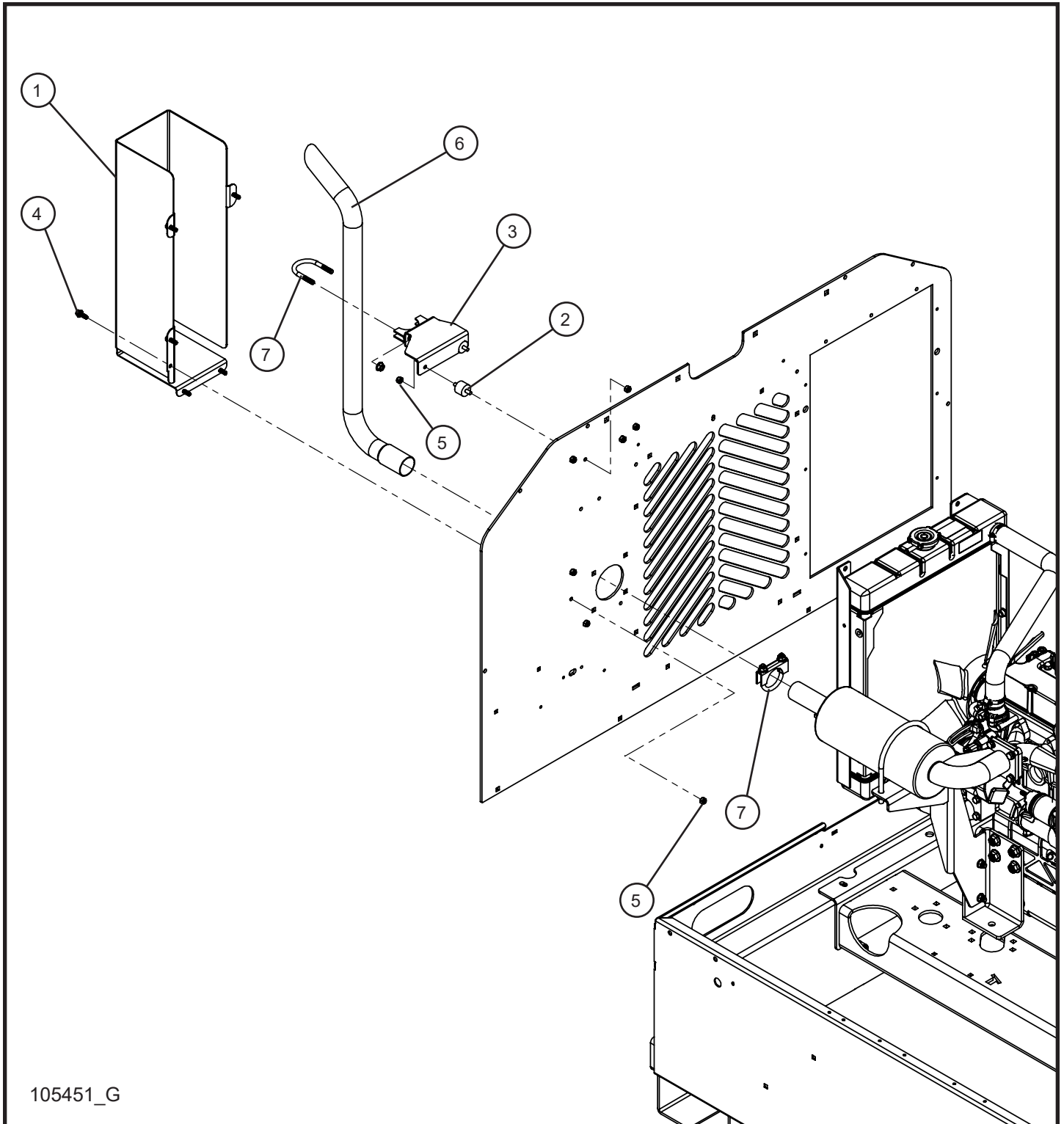

105451_G

10.7 - CAT C1.1 Vertical Exhaust Pipe Option

Item	Part No.	Part Description	Qty.
1	105034P	TAILPIPE SHIELD REAR/VERTICAL EXIT	1
2	330057	BOX MOUNT RUBBER	2
3	105454P	BRACKET SUPPORT VERTICAL EXHAUST	1
4	056002	1/4-20 X 3/4 HEX SERRATED FLANGE SCREW	6
5	044023	1/4-20 NYLOCK HEX NUT PL	10
6	105450	EXHAUST ELBOW VERTICAL 1.5" OD	1
7	112211	1-5/8 MUFFLER CLAMP EXHAUST	2

NS - Not Shown

* * * - Contact Allmand for more information.

11.1 - CAT C1.5 Turbo Engine Assembly Group (1 of 4)

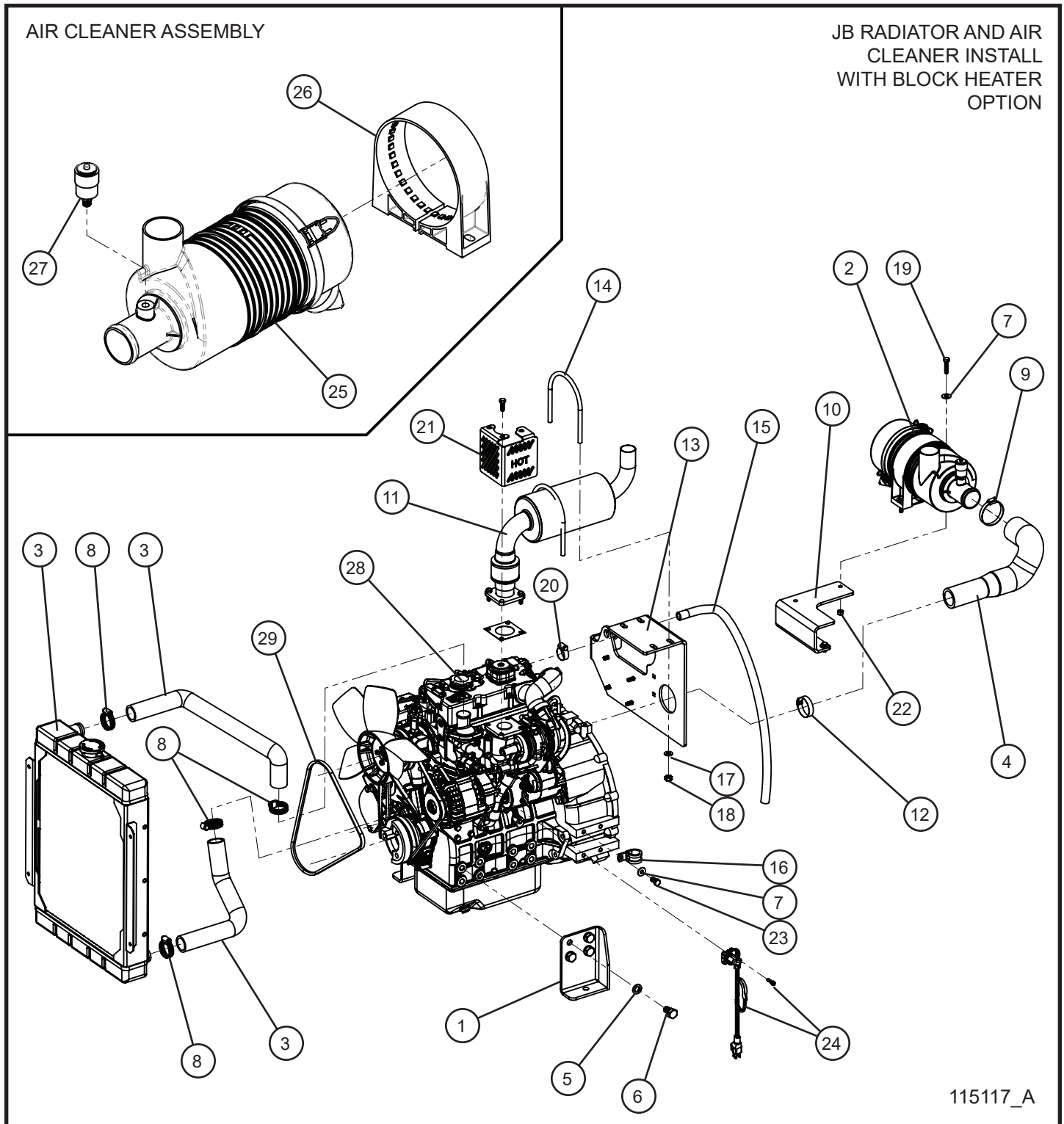

11.1 - CAT C1.5 Turbo Engine Assembly Group (1 of 4)

Item	Part No.	Part Description	Qty.
1	106218P	ENGINE RIGHT FOOT WELDMENT CAT C1.5T	1
2	106072	AIR CLEANER ASSEMBLY CAT C1.5T	1
3	106221	RADIATOR KIT JB CAT C1.5T	1
4	106073	HOSE AIR INTAKE CAT C1.5T	1
5	043095	9/16 SPLITLOCK WASHER PL	4
6	046430	M14 x 1.5 x 25 HEX HEAD CS GR8.8 PL	4
7	047010	5/16 FLAT WASHER PL	3
8	045035	#20 HOSE CLAMP	4
9	043038	#32 HOSE CLAMP	1
10	106264P	AIR CLEANER BRACKET CAT C1.5T	1
11	106252	MUFFLER CAT C1.5T	1
12	046036	#24 HOSE CLAMP	1
13	105745P	MUFFLER BRACKET CAT C1.5T	1
14	105744	4.75" MUFFLER U-BOLT	2
15	081020	HOSE J30R6 RUBBER x 36.0	1
16	022083	#16 CLAMP CUSH 3/8 HOLE	1
17	047016	3/8 FLAT WASHER SAE ZINC	4
18	044080	3/8-16 TOP LOCK HEX NUT PL	4
19	102127	8MM x 35MM x 1.25 HEX GR8.8 PLATED	2
20	045032	#12 HOSE CLAMP	1
21	106233P	FINGER GUARD TURBO CAT C1.5T	1
22	042081	M8 x 1.25MM NYLOCK HEX NUT PL METRIC	2
23	046105	3/8-16 x 3/4 HEX HEAD CS GR8 PL	1
24	103322	400W 120V 40mm BLOCK HEATER	1
25	104061	DONALDSON AIR CLEANER ASSEMBLY	1
	15-000125	PRIMARY FILTER	1
	104071	SAFETY FILTER	1
26	921140	AIR CLEANER BAND MOUNT	1
27	104795	AIR FILTER SERVICE INDICATOR KIT	1
28	125225	CAT C1.5 TURBO ENGINE 50/60Hz ELECTRONIC GOVERNOR	1
29	125801	V-BELT GATES REPLACEMENT CAT/PERKINS 1.5T	1
NS	106230	ELECTRONIC GOVERNOR HARNESS CAT C1.5T	1
NS	105190	HARNESS ENGINE CAT C1.5T	1
NS	105874	CAT 1.5 CHARGE CIRCUIT FUSE	1
NS	106553	SCHEMATIC CAT C1.5T ENGINE	1

11.1 - CAT C1.5 Turbo Engine Assembly Group (2 of 4)

FILTERS INSTALL

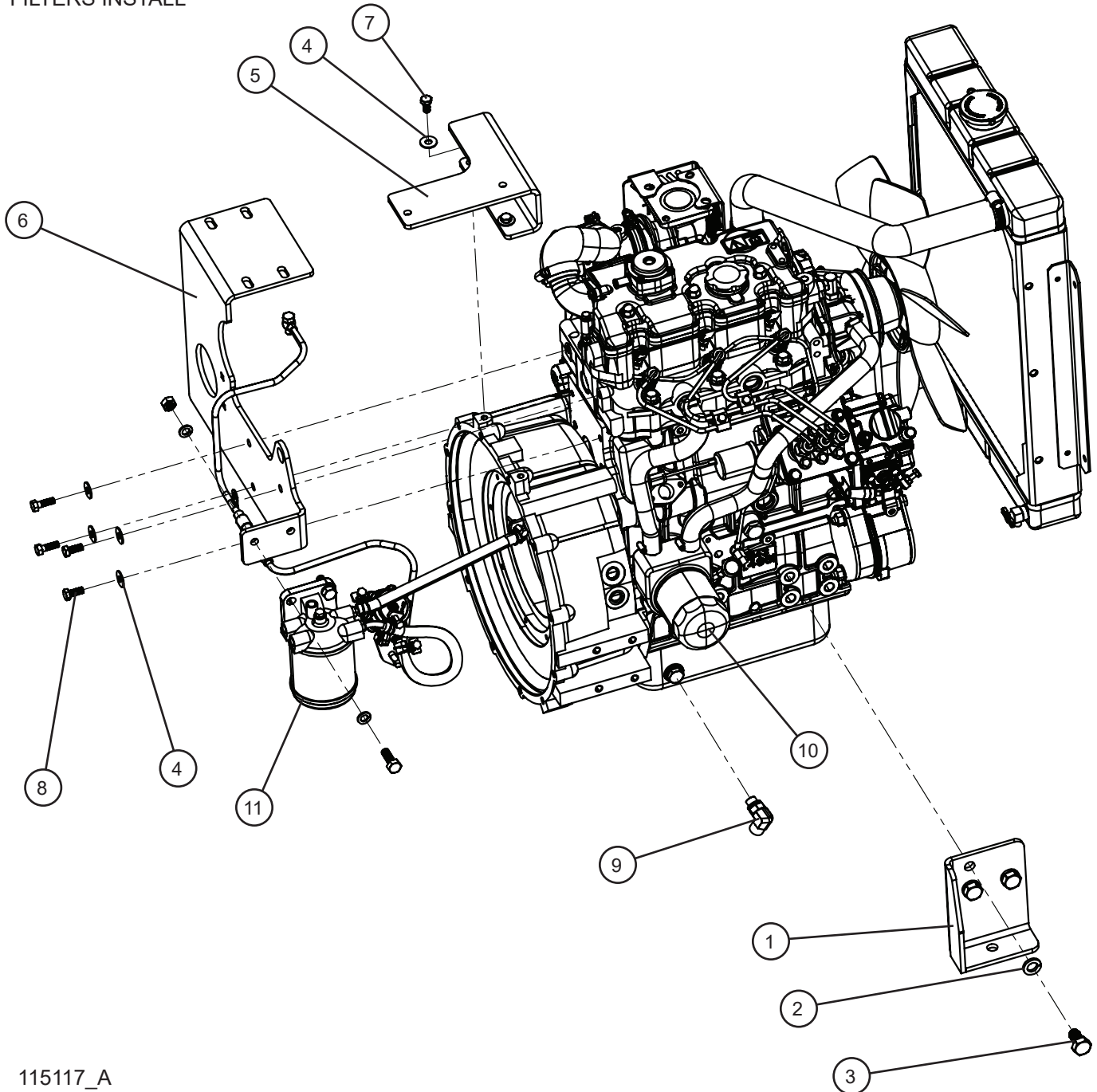

115117_A

11.1 - CAT C1.5 Turbo Engine Assembly Group (2 of 4)

Item	Part No.	Part Description	Qty.
1	106219P	ENGINE LEFT FOOT WELDMENT CAT C1.5T	1
2	043095	9/16 SPLITLOCK WASHER PL	3
3	046430	M14 x 1.5 x 25 HEX HEAD CS GR8.8 PL	3
4	047010	5/16 FLAT WASHER PL	6
5	106264P	AIR CLEANER BRACKET CAT C1.5T	1
6	105745P	MUFFLER BRACKET CAT C1.5T	1
7	042027	M8 x 16MM x 1.25MM HEX HEAD CS GR10.9 PL	2
8	042033	M8 x 20MM x 1.25MM HEX HEAD CS GR10.9 PL	2
9	108981	10JIC X 16mm HYDRAULIC 90° FITTING	1
10	650304	CAT C1.5T OIL FILTER	1
11	103155	CAT C1.5T FUEL FILTER	1

11.1 - CAT C1.5 Turbo Engine Assembly Group (3 of 4)

JB RADIATOR MOUNTING
WITH FINGER GUARD AND
FAN SHROUD ASSEMBLY

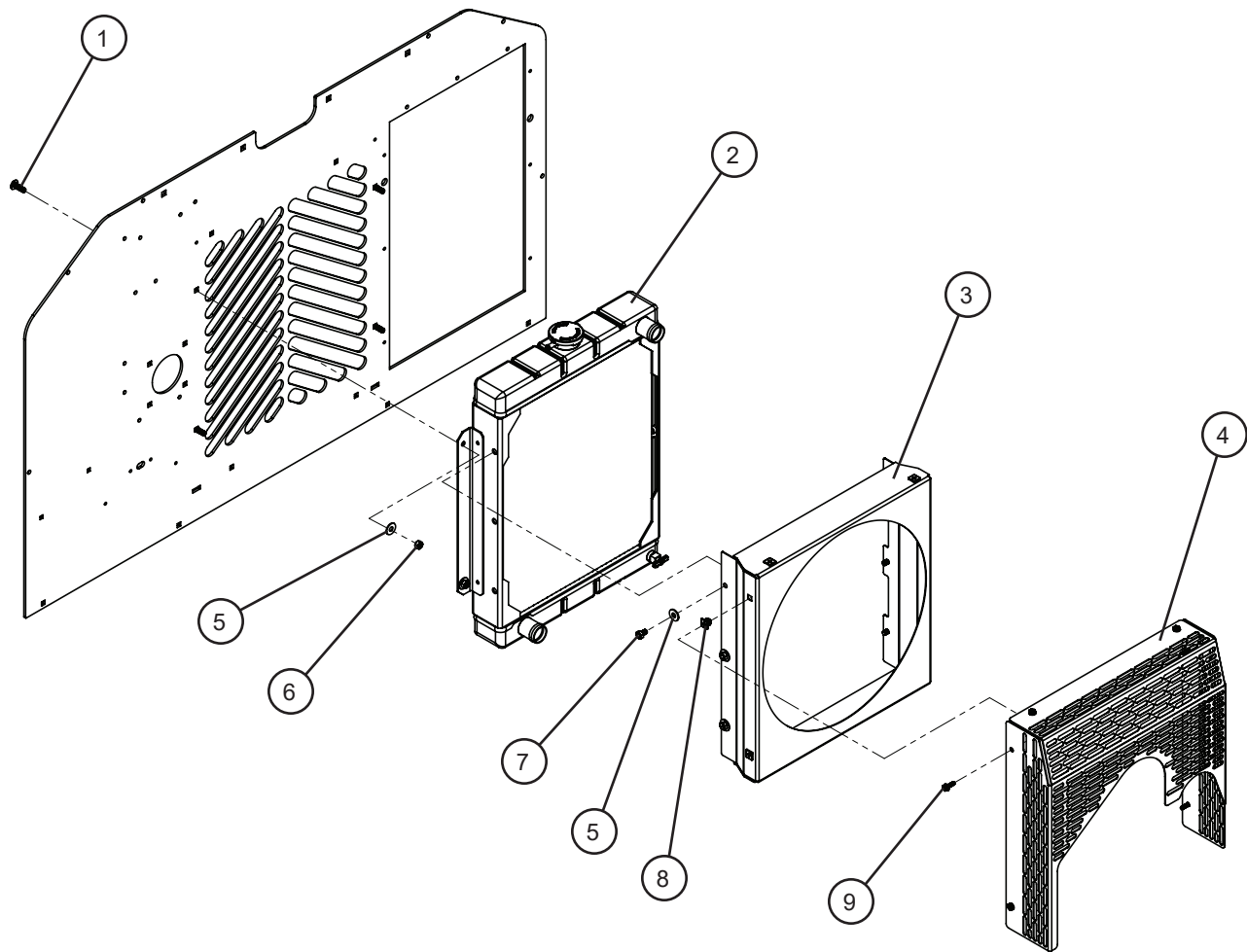

115117_A

11.1 - CAT C1.5 Turbo Engine Assembly Group (3 of 4)

Item	Part No.	Part Description	Qty.
1	053020	5/16-18 x 1 CARRIAGE BOLT	4
2	106221	RADIATOR KIT JB C1.5T	1
3	105739P	FAN SHROUD CAT C1.5T	1
4	105740P	FINGER GUARD CAT C1.5T	1
5	047010	5/16 FLAT WASHER PL	10
6	044033	5/16-18 NYLOCK HEX NUT PL	4
7	046046	5/16-18 x 1/2 HEX HEAD CS GR5 PL	6
8	105408	GROMMET NUT DOUBLE SPLIT	6
9	041070	1/4-20 x 3/4 SL-HEX WASHER HEAD MS TP F	6

11.1 - CAT C1.5 Turbo Engine Assembly Group (4 of 4)

MUFFLER TAIL PIPE AND
ELECTRONIC GOVERNOR
STRINGER INSTALL

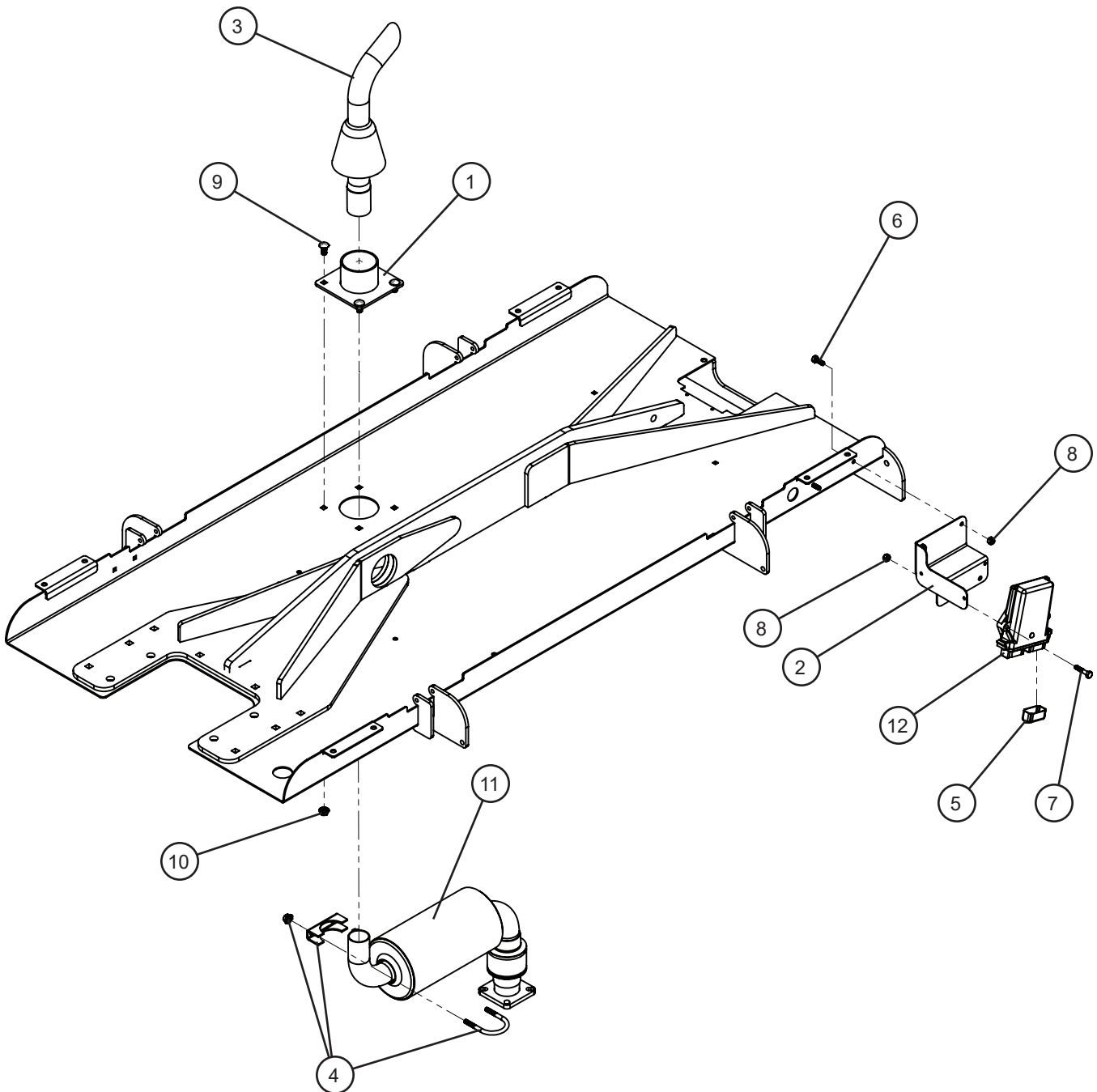

115117_A

11.1 - CAT C1.5 Turbo Engine Assembly Group (4 of 4)

Item	Part No.	Part Description	Qty.
1	106249P	CAT C1.5T STRINGER TOP EXHAUST WELDMENT	1
2	113476P	MAXI-LITE SHOCKER CONTROLLER BRACKET	1
3	106253	CAT C1.5T TAILPIPE VERTICAL	1
4	112211	1-5/8 EXHAUST MUFFLER CLAMP	1
5	106229	DUST CAP DTM12P-DC	1
6	046010	1/4-20 x 3/4 HEX HEAD CS GR5 SS	2
7	046020	1/4-20 x 1 1/4 HEX HEAD CS GR5 PL	2
8	044023	1/4-20 NYLOCK HEX NUT PL	4
9	102081	5/16-18 x 3/4 CARRIAGE BOLT	4
10	057006	5/16-18 SERRATED FLANGE BOLT	4
11	106252	MUFFLER CAT C1.5T	1
12	***	CAT C1.5T ELECTRONIC GOVERNOR	1

11.2 - CAT C1.5 Turbo Engine Fuel Lines

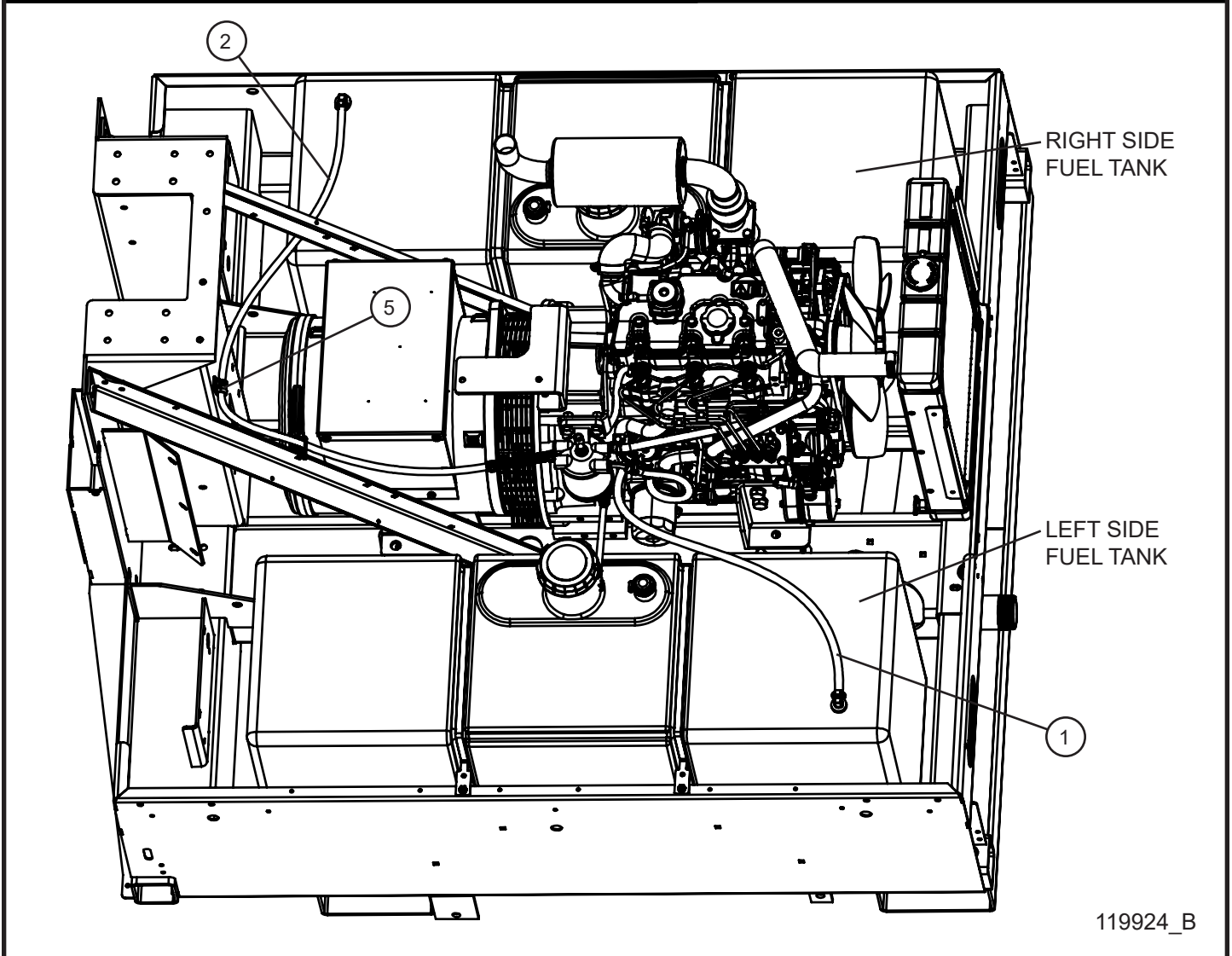
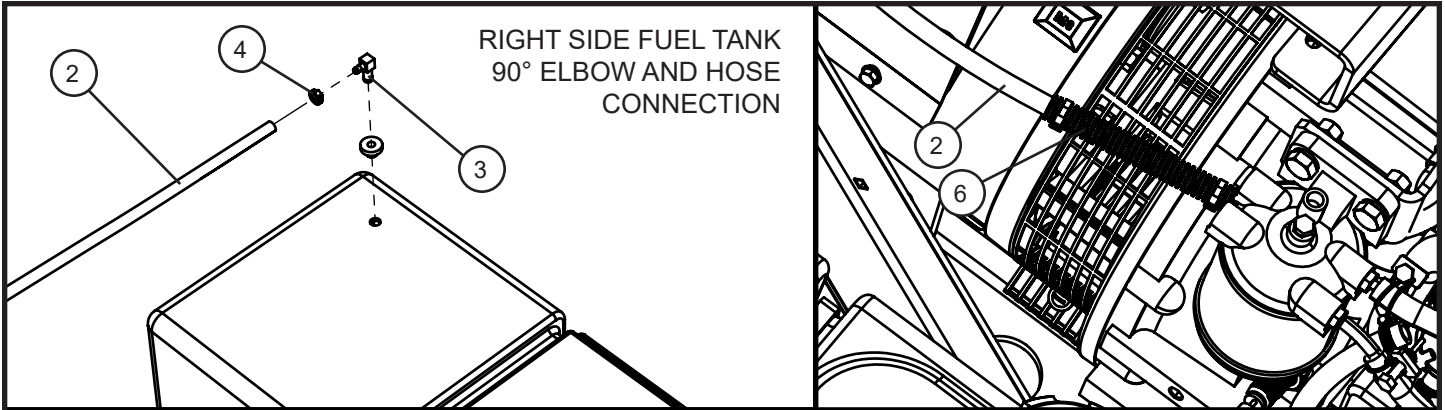

119924_B

11.2 - CAT C1.5 Turbo Engine Fuel Lines

Item	Part No.	Part Description	Qty.
1	081018	HOSE 5/16 FUEL LINE x 35.00	1
2	081016	HOSE 1/4 FUEL LINE X 70.00	1
3	105106	DAPCO 90° ELBOW	1
4	433400	#4 HOSE CLAMP	4
5	022018	#8 CUSH CLAMP	1
	053020	5/16-18 X 1 CARRIAGE BOLT	1
	057006	5/16-18 SERRATED FLANGE NUT	1
6	022205	1/2" SPLIT LOOM X 5.00	1

11.3 - CAT C1.5 Turbo Webasto Thermo Top C Heater Lines

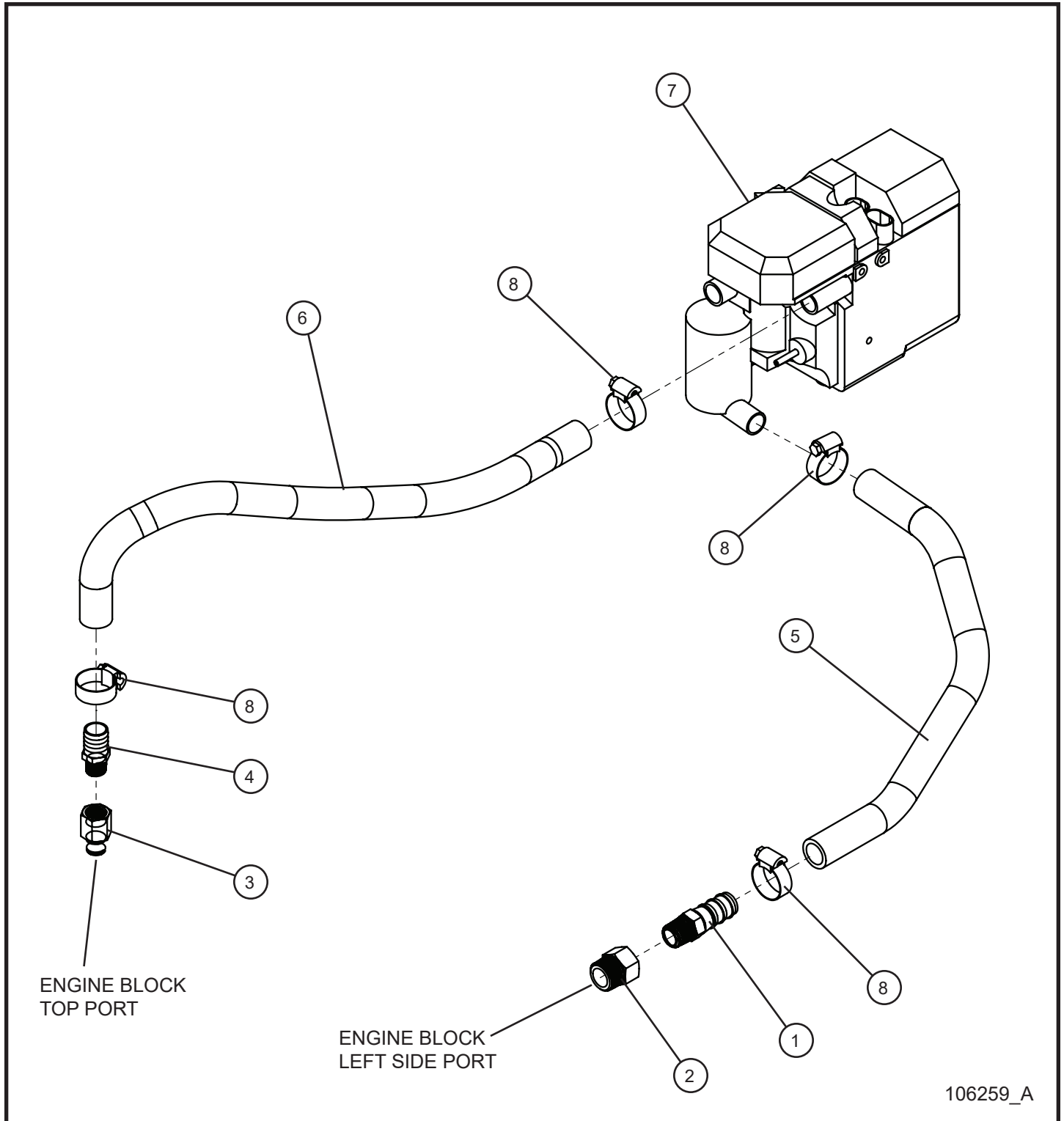

11.3 - CAT C1.5 Turbo Webasto Thermo Top C Heater Lines

Item	Part No.	Part Description	Qty.
1	104954	BARB ADAPTOR 1/2 NPT MALE x 3/4 HOSE	1
2	104955	1/2 NPT FEMALE x 3/4 BSPT MALE ADAPTOR ZINC PL STEEL	1
3	104798	FITTING ADAPTOR 3/8" BSPT TO 3/8" NPT	1
4	104683	FITTING HOSE BARB 3/8" NPT - 3/4" BARB	1
5	105016	3/4" HEATER HOSE x 18.0	1
6	105016	3/4" HEATER HOSE x 25.0	1
7	104946	WEBASTO TT C DIESEL FIRED COOLANT HEATER KIT	1
8	045032	#12 HOSE CLAMP	4

11.4 - CAT C1.5 Turbo Webasto Thermo Top EVO Heater Lines

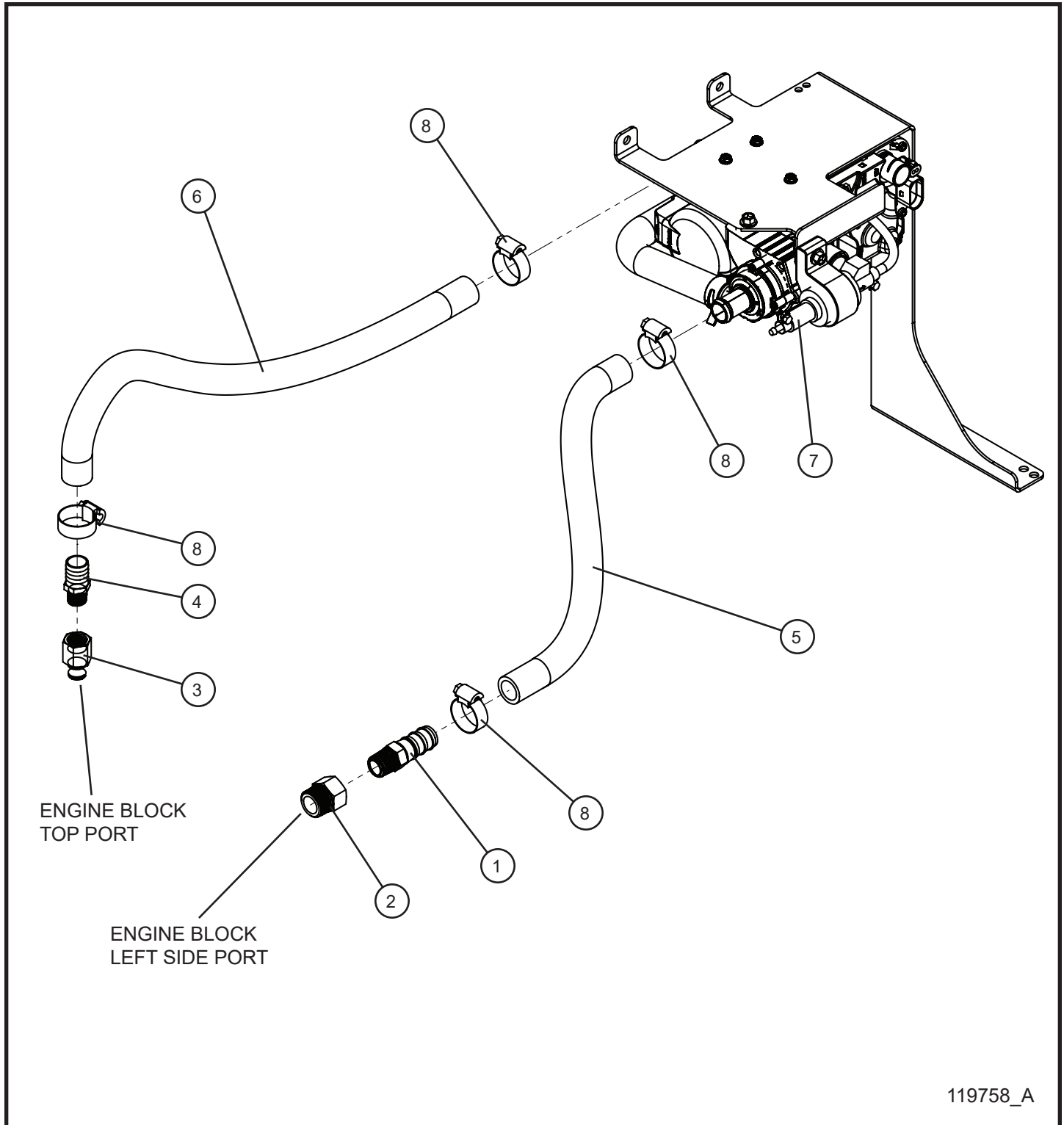

11.4 - CAT C1.5 Turbo Webasto Thermo Top EVO Heater Lines

Item	Part No.	Part Description	Qty.
1	104954	BARB ADAPTOR 1/2 NPT MALE x 3/4 HOSE	1
2	104955	1/2 NPT FEMALE x 3/4 BSPT MALE ADAPTOR ZINC PL STEEL	1
3	104798	FITTING ADAPTOR 3/8" BSPT TO 3/8" NPT	1
4	104683	FITTING HOSE BARB 3/8" NPT - 3/4" BARB	1
5	105016	3/4" HEATER HOSE x 15.0	1
6	105016	3/4" HEATER HOSE x 31.0	1
7	118278	WEBASTO TT EVO DIESEL FIRED COOLANT HEATER KIT	1
8	045032	#12 HOSE CLAMP	4

11.5 - CAT C1.5 Turbo Engine Shocker Group (1 of 2)

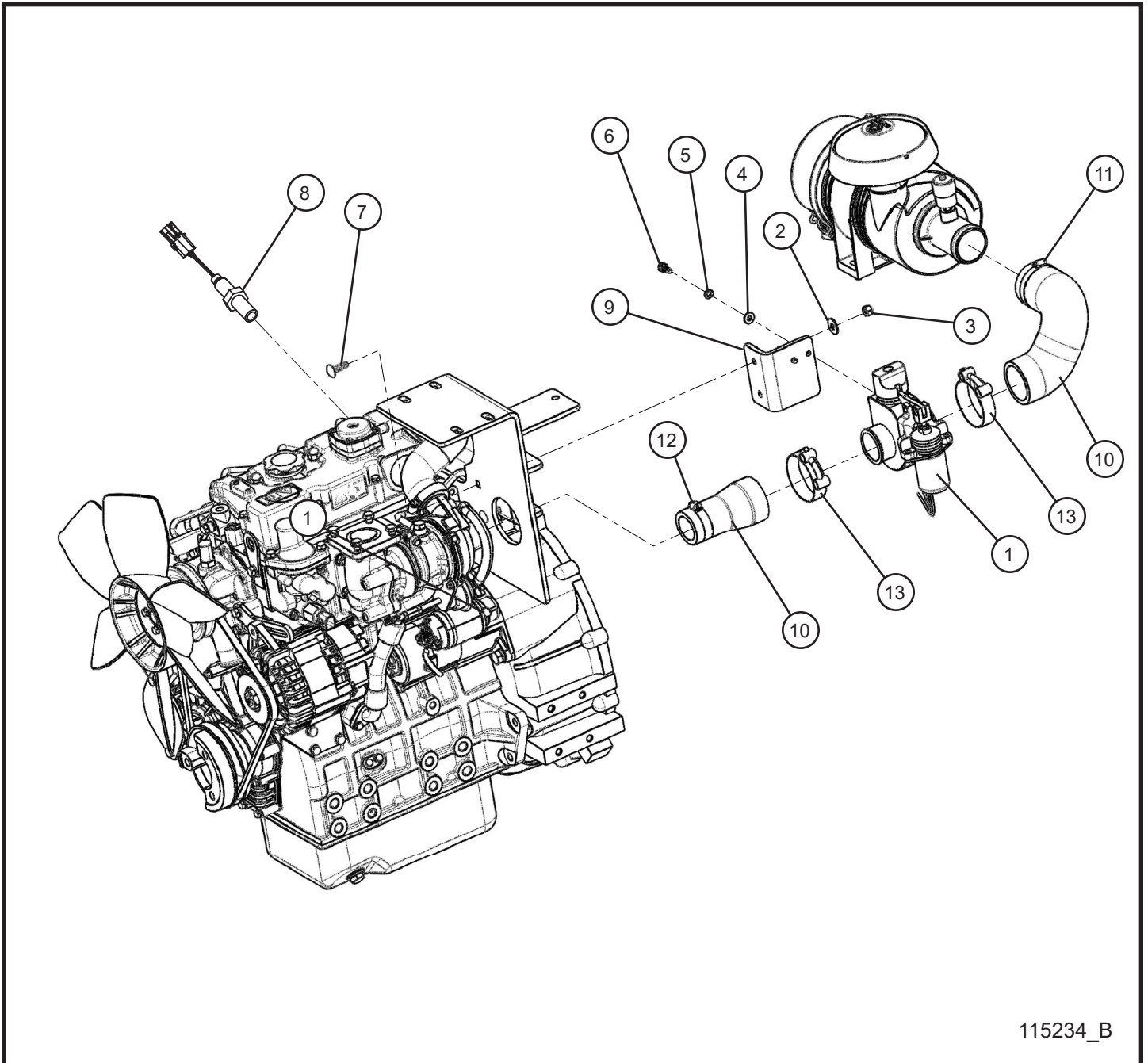

11.5 - CAT C1.5 Turbo Engine Shocker Group (1 of 2)

Item	Part No.	Part Description	Qty.
1	105810	SHOCKER 2" VALVE DELPHI 3 PIN CONNECTOR	1
2	047010	5/16 FLAT WASHER	2
3	044033	5/16-18 NYLOCK HEX NUT	2
4	047005	1/4 FLAT WASHER PL	2
5	043020	1/4 SPLITLOCK WASHER	2
6	046006	1/4-20 x 5/8 HEX HEAD BOLT	2
7	053020	5/16-18 x 1 CARRIAGE BOLT PL	2
8	105536	RPM SENSOR 18mm x 1.5	1
9	106261P	BRACKET SHOCKER C1.5T	1
10	106073	HOSE AIR INTAKE CAT C1.5T	1
11	043038	#32 HOSE CLAMP	1
12	046036	#24 HOSE CLAMP	1
13	105649	2 INCH STAINLESS STEEL T-BOLT CLAMP	2
NS	105702	SHOCKER SETUP INSTRUCTIONS	1
NS	105705	SHOCKER 2" VALVE KIT	1
NS	105802	SHOCKER VALVE HARNESS	1
NS	106156	SHOCKER VALVE HARNESS SCHEMATIC	1

11.5 - CAT C1.5 Turbo Engine Shocker Group (2 of 2)

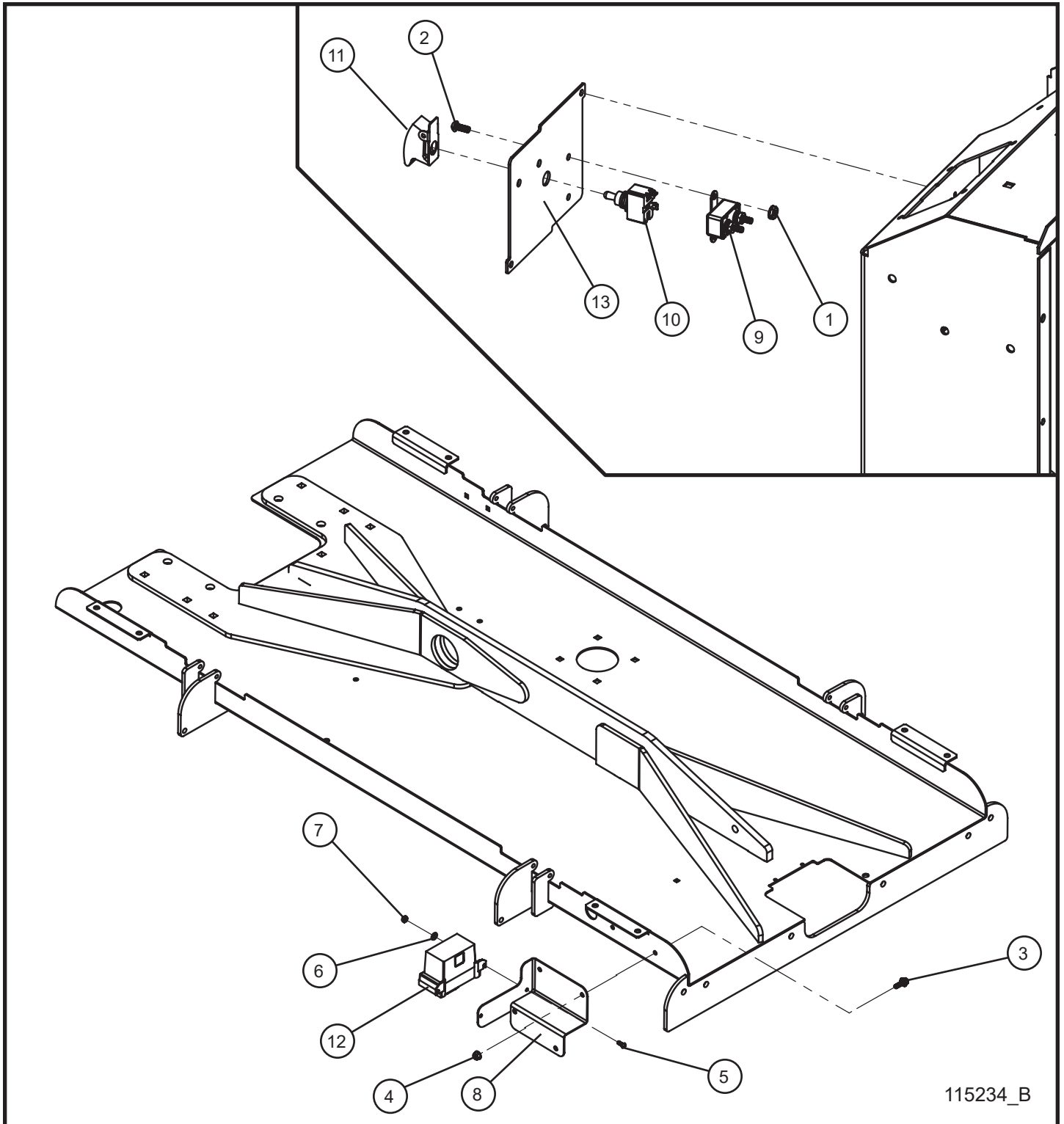

11.5 - CAT C1.5 Turbo Engine Shocker Group (2 of 2)

Item	Part No.	Part Description	Qty.
1	044016	#10-24 KEPS HEX NUT	2
2	041024	#10-24 x 1/2 PH-ROUND HEAD MACHINE SCREW	2
3	056002	1/4-20 x 3/4 HEX SERRATED FLANGE SCREW	2
4	057001	1/4-20 HEX NYLOCK FLANGE NUT	2
5	041021	#10-24 x 1/2 PH-ROUND HEAD MACHINE SCREW	2
6	047070	#10 FLAT WASHER	2
7	044018	#10-24 NYLOCK HEX NUT	2
8	113476P	MAXI-LITE SHOCKER CONTROLLER BRACKET	1
9	105636	20 AMP BREAKER	1
10	340009	15A 125V ON/OFF TOGGLE SWITCH	1
11	105645	CONTROLLER PASS TOGGLE SWITCH GUARD	1
12	105692	R5 SHOCKER CONTROLLER	1
13	111228P	MAXI-LITE COMPONENT BOX BACK COVER	1
NS	105702	SHOCKER SETUP INSTRUCTIONS	1
NS	105705	SHOCKER 2" VALVE KIT	1
NS	105802	SHOCKER VALVE HARNESS	1
NS	106156	SHOCKER VALVE HARNESS SCHEMATIC	1

11.6 - CAT C1.5 Turbo Engine PacBrake Group

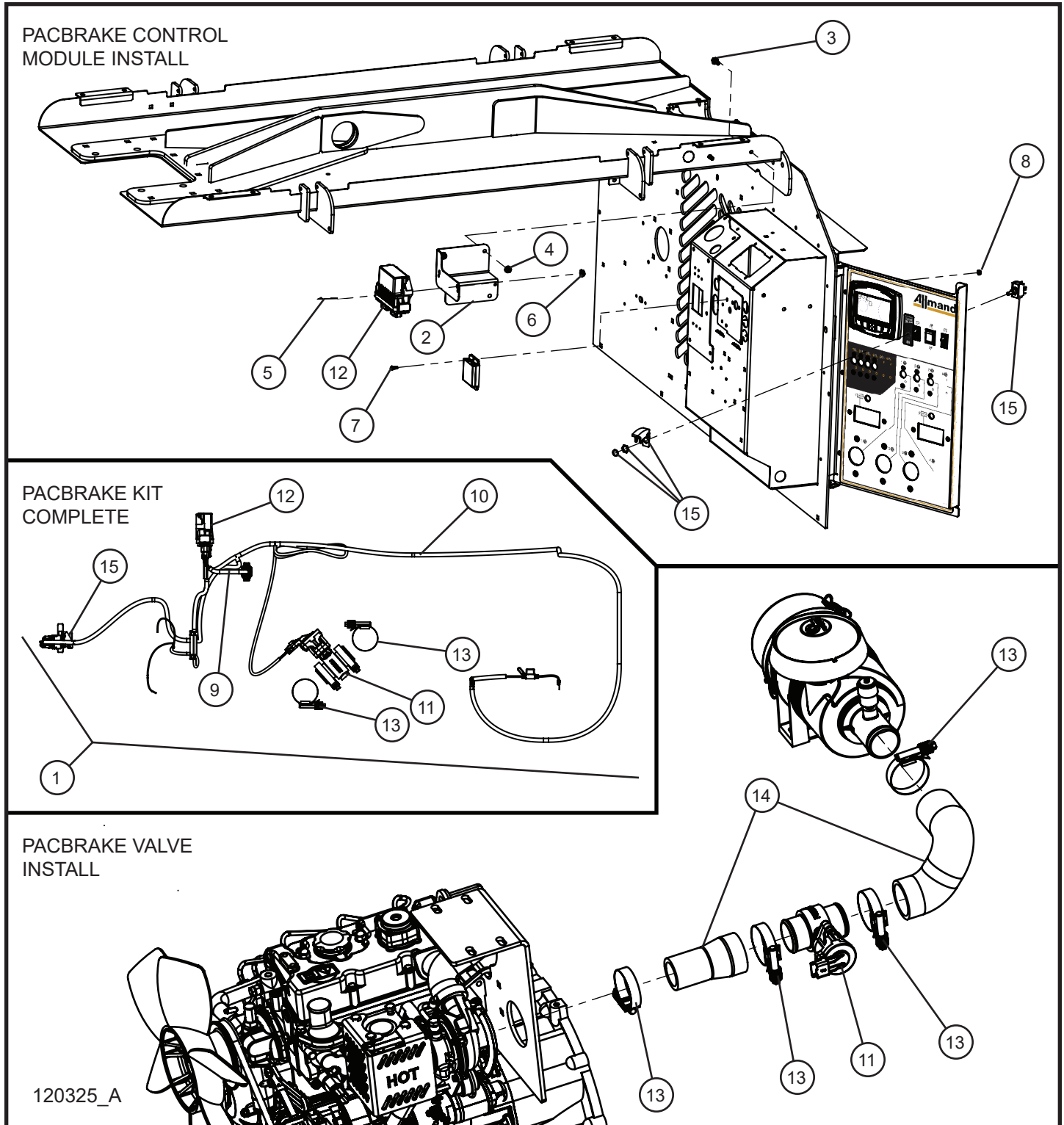

11.6 - CAT C1.5 Turbo Engine PacBrake Group

Item	Part No.	Part Description	Qty.
1	122098	PACBRAKE 1.75" AIR INTAKE VALVE KIT COMPLETE MAXI-LITE	1
2	113476P	MAXI-LITE SHOCKER CONTROLLER BRACKET	1
3	056002	1/4-20 X 3/4 HEX SERRATED FLANGE SCREW	2
4	057001	1/4-20 HEX NYLOCK FLANGE NUT	2
5	056012	1/4-20 x 1 1/2 SERRATED FLANGE HEX HEAD SCREW	2
6	057000	1/4-20 HEX SERRATED FLANGE NUT	2
7	041012	#8-32 X 1/2 PL SCREW MS	2
8	044003	#8-32 NC KEPS NUT	2
9	122731	PACBRAKE AC FREQUENCY WIRE HARNESS MAXI-LITE	1
10	122732	PACBRAKE DC WIRE HARNESS MAXI-LITE	1
11	122747	PACBRAKE 2.00" AIR INTAKE VALVE	1
12	122736	PACBRAKE AIR INTAKE VALVE CONTROL MODULE	1
13	122737	PACBRAKE SAE 262 BAND CLAMP	4
14	106073	HOSE AIR INTAKE CAT C1.5T	1
15	122739	PACBRAKE TOGGLE SWITCH KIT	1
NS	103864	FUSE HOLDER INLINE BLADE	1
NS	104990	FUSE BLADE 2 AMP ATO/ATC	1
NS	105844	15 AMP MINI FUSE	1
NS	117814	WIRE SCHEMATIC PACBRAKE AIR VALVE	1

NS - Not Shown

* * * - Contact Allmand for more information.

11.7 - CAT C1.5 Turbo Engine Exhaust Blanket

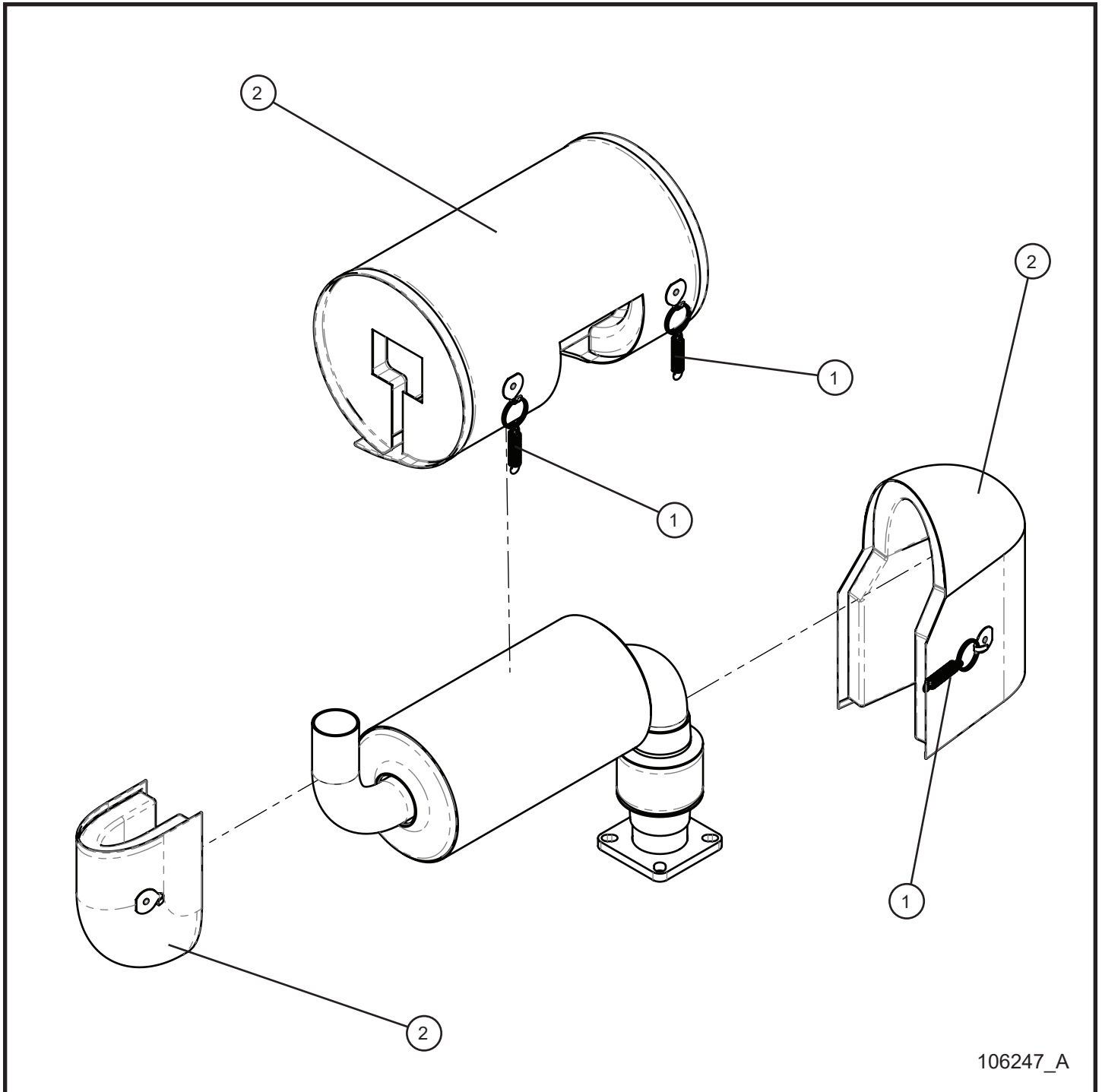

106247_A

11.7 - CAT C1.5 Turbo Engine Exhaust Blanket

Item	Part No.	Part Description	Qty.
1	103827	BLANKET SPRING	4
2	106549	MUFFLER BLANKET CAT C1.5T	1

12.1 - Kubota D1005/1105 Engine Assembly Group (1 of 5)

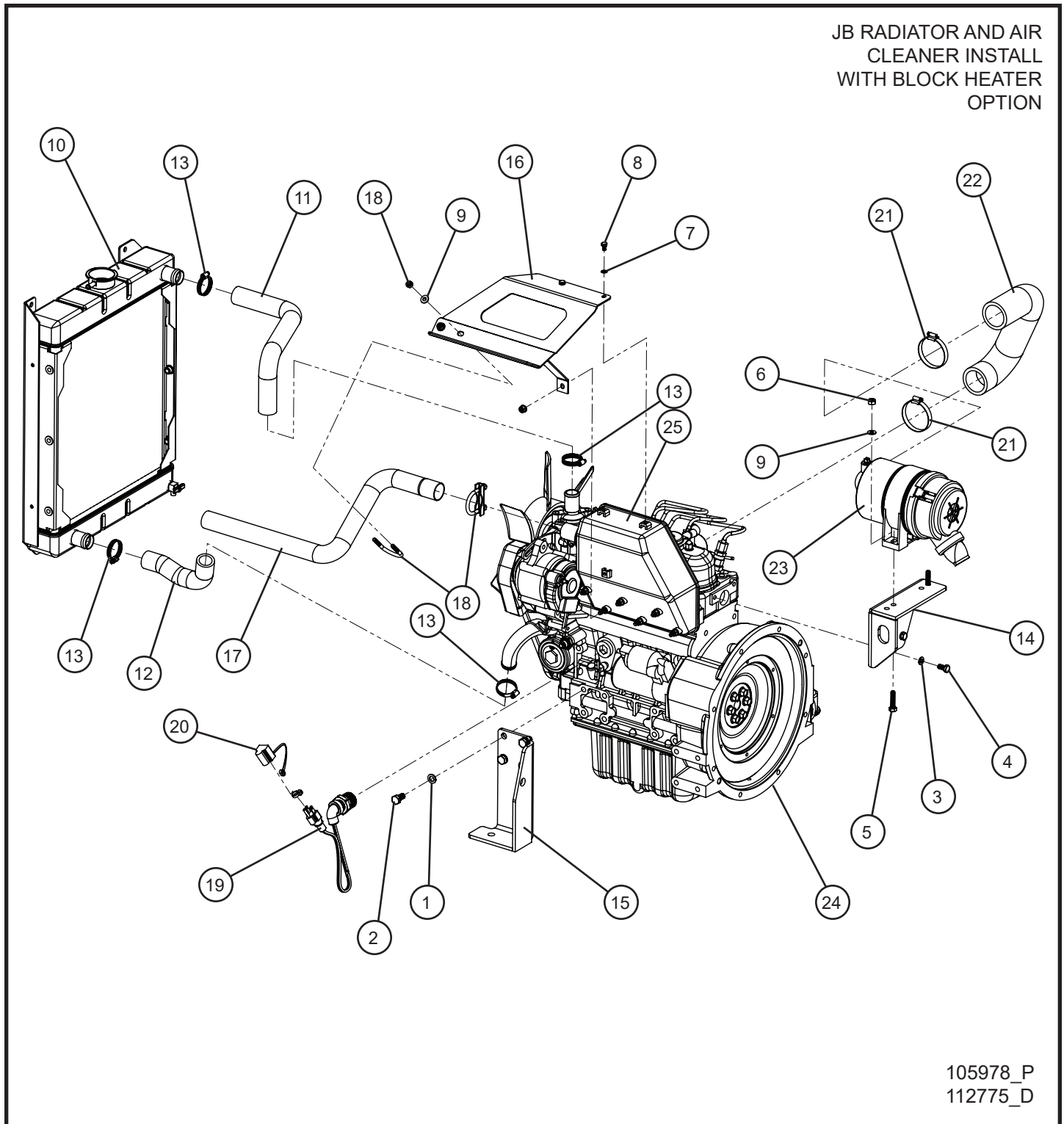

105978_P
112775_D

12.1 - Kubota D1005/1105 Engine Assembly Group (1 of 5)

Item	Part No.	Part Description	Qty.
1	042151	M10 SPLIT LOCK WASHER	4
2	042038	M10 x 20mm x 1.25mm HEX HEAD BOLT	4
3	043055	5/16 SPLITLOCK WASHER	2
4	042027	M8 x 16mm x 1.25mm HEX HEAD BOLT	2
5	102127	M8 x 35mm x 1.25mm HEX HEAD BOLT	2
6	042081	M8 x 1.25mm NYLOCK HEX NUT	2
7	043050	1/4 INTL TOOTH LOCK WASHER	2
8	042018	M6 x 10mm x 1.0mm HEX HEAD BOLT	2
9	047005	1/4 FLAT WASHER	4
10	105393	JB RADIATOR SMALL ENGINES 1.0L / 1.1L	1
11	105391	RADIATOR HOSE UPPER KUBOTA	1
12	105392	RADIATOR HOSE LOWER KUBOTA	1
13	045034	#16 HOSE CLAMP	4
14	105800P	MOUNT WELDED AIR FILTER KUBOTA	1
15	103470P	BRACKET ENGINE FOOT RIGHT WELDMENT KUBOTA	1
16	103579P	TAILPIPE MOUNT D1105 NL PRO II	1
17	109800	TAIL PIPE KUBOTA	1
18	713086	1 3/8 MUFFLER CLAMP	2
19	352373	KUBOTA D1005/D1105 BLOCK HEATER	1
20	105995	END COVER 120V CORD	1
21	045038	#32 HOSE CLAMP	2
22	101734	AIR INTAKE HOSE SMALL ENGINES	1
23	650262	AIR CLEANER RADIAL SEAL	1
	650263	MOUNTING BAND AIR CLEANER	1
	650290	DONALDSON AIR FILTER	1
24	104479	ENGINE D1005 NRTC/NTE T4F KUBOTA	1
	105397	ENGINE D1105 NRTC/NTE T4F KUBOTA	1
25	352139	KUBOTA BOX MUFFLER	1
NS	105406	KUBOTA JB RADIATOR KIT	1
NS	108043	KUBOTA ENGINE HARNESS	1
NS	105875	KUBOTA D1005 30AMP FUSE CHARGE CIRCUIT	1
	105872	JCASE 30AMP FUSE	1
NS	112774	KUBOTA D1105 40AMP FUSE CHARGE CIRCUIT	1
	106309	JCASE 40AMP FUSE	1
NS	112776	KUBOTA D1105 40AMP ENGINE HARNESS SCHEMATIC	1
NS	108044	KUBOTA D1005 30AMP ENGINE HARNESS SCHEMATIC	1

12.1 - Kubota D1005/1105 Engine Assembly Group (2 of 5)

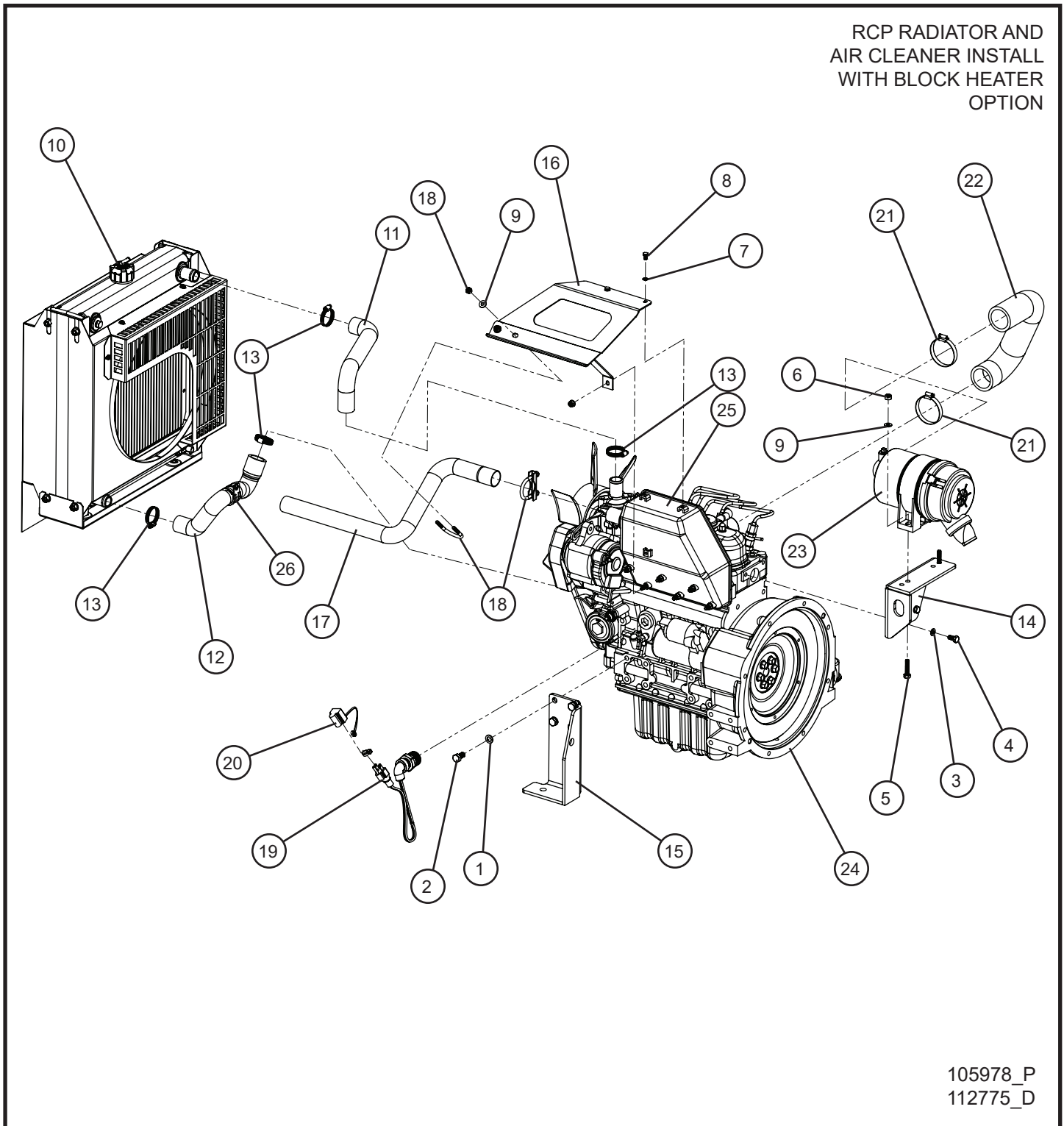

12.1 - Kubota D1005/1105 Engine Assembly Group (2 of 5)

Item	Part No.	Part Description	Qty.
1	042151	M10 SPLIT LOCK WASHER	4
2	042038	M10 x 20mm x 1.25mm HEX HEAD BOLT	4
3	043055	5/16 SPLITLOCK WASHER	2
4	042027	M8 x 16mm x 1.25mm HEX HEAD BOLT	2
5	102127	M8 x 35mm x 1.25mm HEX HEAD BOLT	2
6	042081	M8 x 1.25mm NYLOCK HEX NUT	2
7	043050	1/4 INTL TOOTH LOCK WASHER	2
8	042018	M6 x 10mm x 1.0mm HEX HEAD BOLT	2
9	047005	1/4 FLAT WASHER	4
10	103422	RCP RADIATOR	1
11	103424	RCP RADIATOR HOSE TOP	1
12	103423	RCP RADIATOR HOSE BOTTOM	1
13	045034	#16 HOSE CLAMP	4
14	105800P	MOUNT WELDED AIR FILTER KUBOTA	1
15	103470P	BRACKET ENGINE FOOT RIGHT WELDMENT KUBOTA	1
16	103579P	TAILPIPE MOUNT D1105 NL PRO II	1
17	109800	TAIL PIPE KUBOTA	1
18	713086	1 3/8 MUFFLER CLAMP	2
19	352373	KUBOTA D1005/D1105 BLOCK HEATER	1
20	105995	END COVER 120V CORD	1
21	045038	#32 HOSE CLAMP	2
22	101734	AIR INTAKE HOSE SMALL ENGINES	1
23	650262	AIR CLEANER RADIAL SEAL	1
	650263	MOUNTING BAND AIR CLEANER	1
	650290	DONALDSON AIR FILTER	1
24	105396	ENGINE D1005 NRTC/NTE T4F KUBOTA	1
	105397	ENGINE D1105 NRTC/NTE T4F KUBOTA	1
25	352139	KUBOTA BOX MUFFLER	1
26	103472	#16 CUSH CLAMP	1
NS	103420	KUBOTA RCP RADIATOR HOSE KIT	1
NS	102911	RCP RADIATOR KIT	1
NS	108043	KUBOTA ENGINE HARNESS	1
NS	105875	KUBOTA D1005 30AMP FUSE CHARGE CIRCUIT	1
	105872	JCASE 30AMP FUSE	1
NS	112774	KUBOTA D1105 40AMP FUSE CHARGE CIRCUIT	1
	106309	JCASE 40AMP FUSE	1
NS	112776	KUBOTA D1105 40AMP ENGINE HARNESS SCHEMATIC	1
NS	108044	KUBOTA D1005 30AMP ENGINE HARNESS SCHEMATIC	1

12.1 - Kubota D1005/1105 Engine Assembly Group (3 of 5)

FILTERS AND FUEL
PUMP INSTALL

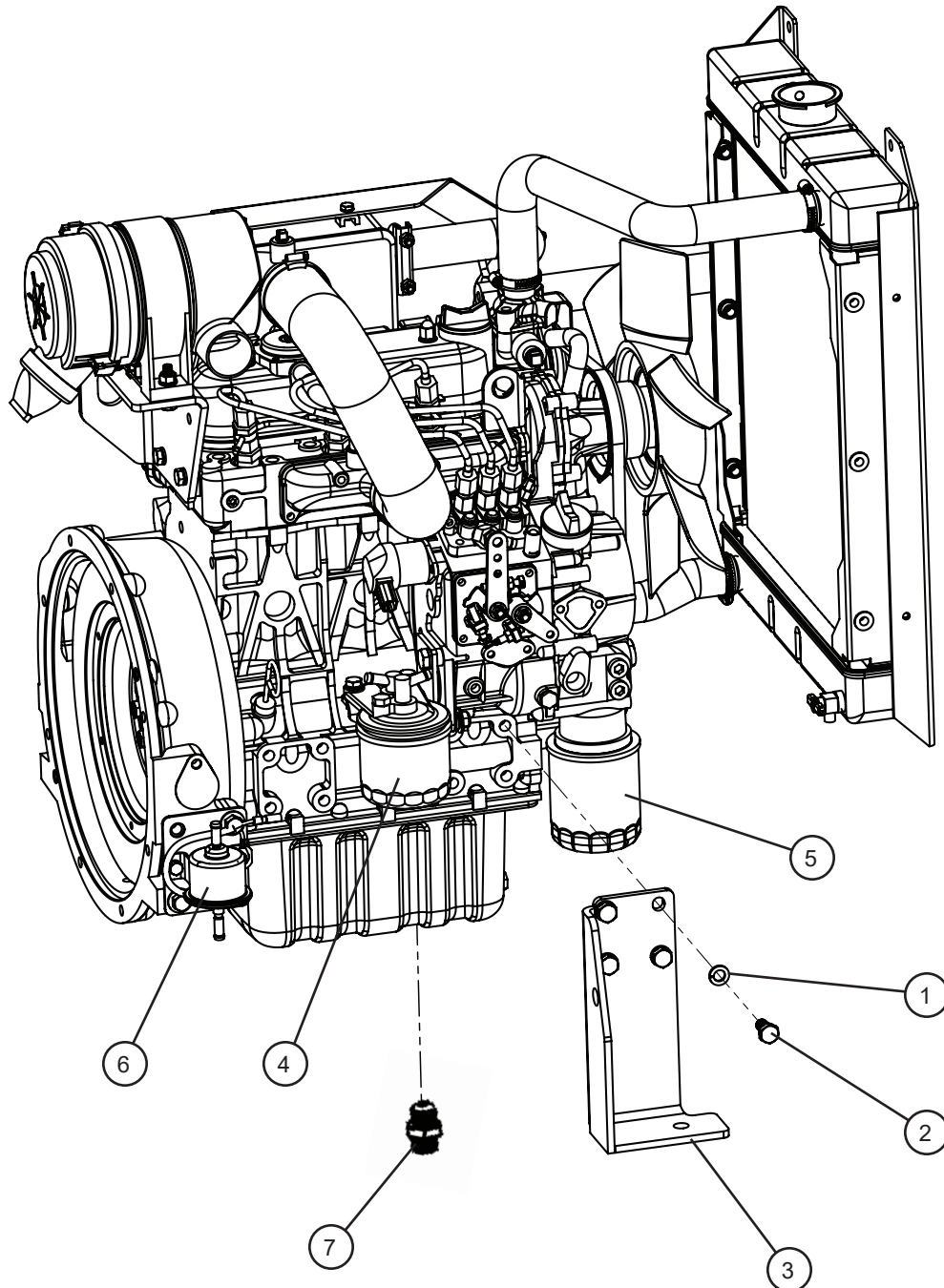

105978_P
112775_D

12.1 - Kubota D1005/1105 Engine Assembly Group (3 of 5)

Item	Part No.	Part Description	Qty.
1	042151	M10 SPLIT LOCK WASHER	4
2	042038	M10 x 20mm x 1.25mm HEX HEAD BOLT	4
3	103469P	BRACKET ENGINE FOOT LEFT WELDMENT KUBOTA	1
4	920745	FUEL FILTER	1
5	920743	OIL FILTER	1
6	103331	FUEL PUMP	1
7	352148	#10 JIC - M22 x 1.5mm UNION	1
NS	043050	1/4 INTL TOOTH LOCK WASHER	1
NS	108962	KUBOTA AIR, FUEL, AND OIL FILTER KIT	1
NS	340302	HIGH TEMP SWITCH	1
NS	340301	OIL PRESSURE SWITCH	1
NS	920751	FUEL SHUT OFF SOLENOID	1

12.1 - Kubota D1005/1105 Engine Assembly Group (4 of 5)

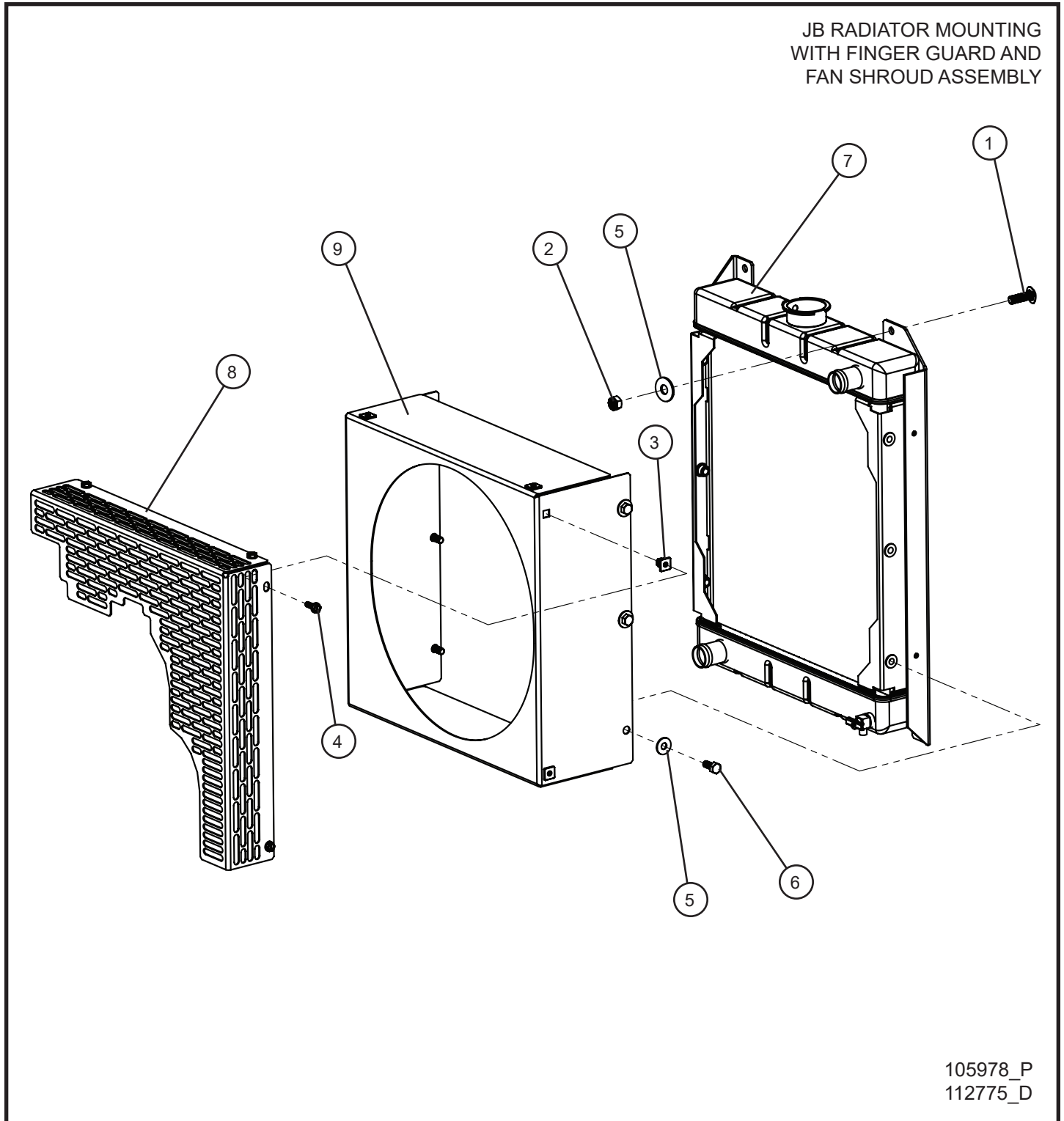

12.1 - Kubota D1005/1105 Engine Assembly Group (4 of 5)

Item	Part No.	Part Description	Qty.
1	053020	5/16-18 CARRIAGE BOLT	4
2	044033	5/16-18 NYLOCK HEX NUT	4
3	105408	GROMMET NUT DOUBLE SPLIT	4
4	041070	1/4-20 x 3/4 SL-HEX WASHER HEAD MACHINE SCREW	4
5	047010	5/16 FLAT WASHER	10
6	046045	5/16-18 x 3/4 HEX HEAD BOLT	6
7	105393	JB RADIATOR SMALL ENGINES 1.0L / 1.1L	1
8	110320P	KUBOTA FINGER GUARD	1
9	105404P	JB RADIATOR FAN SHROUD	1

12.1 - Kubota D1005/1105 Engine Assembly Group (5 of 5)

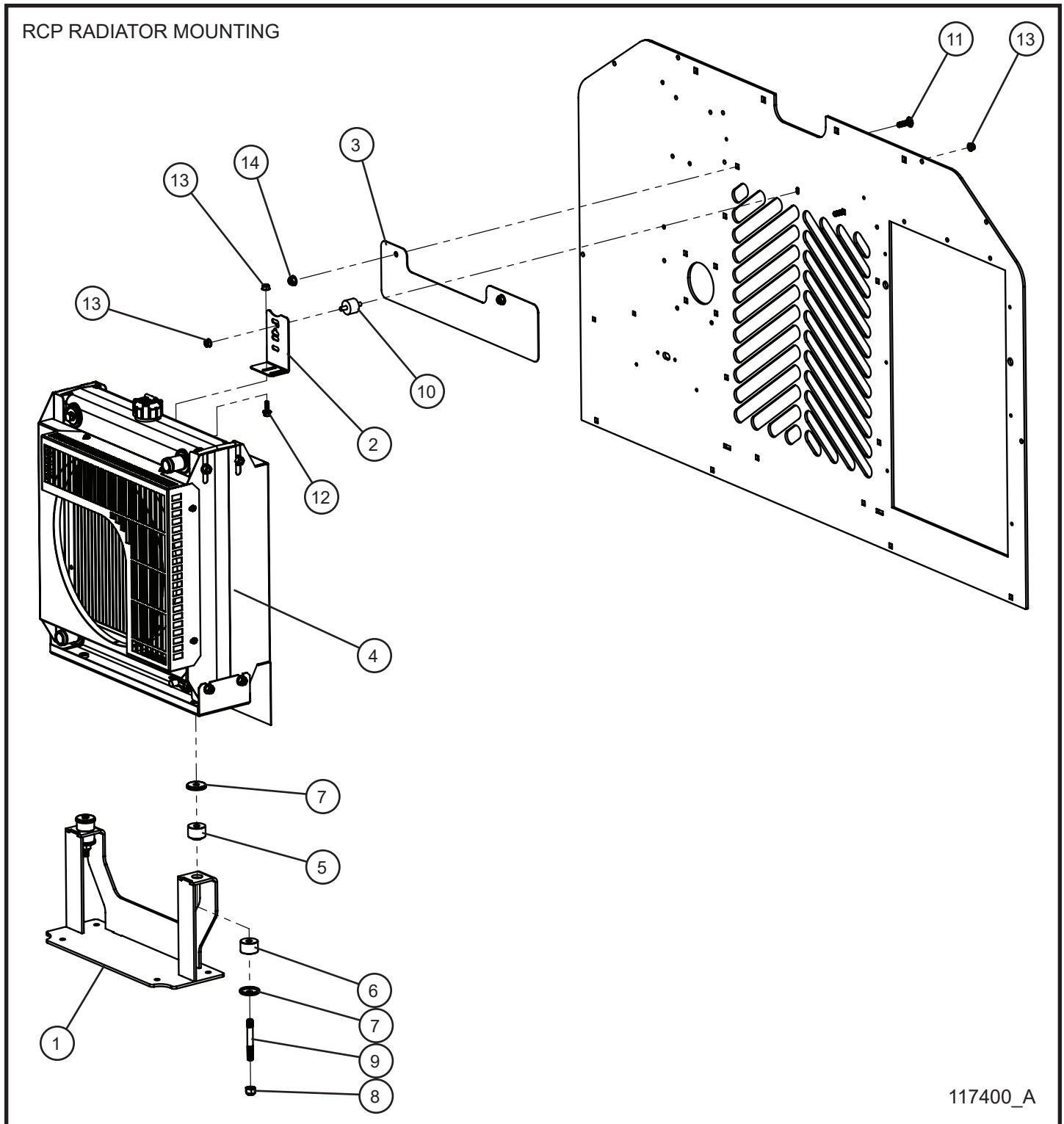

12.1 - Kubota D1005/1105 Engine Assembly Group (5 of 5)

Item	Part No.	Part Description	Qty.
1	105123P	MAXI-LITE KUBOTA RCP RADIATOR MOUNT WELDMENT	1
2	103988P	RCP RADIATOR SHROUD ANGLE BRACKET	1
3	117382P	MAXI-LITE CAT C1.1 RCP RADIATOR PLATE FILLER	1
4	103422	RCP RADIATOR	1
5	116086	RCP RADIATOR RAISED RUBBER ISOLATOR	2
6	116085	RCP RADIATOR RUBBER ISOLATOR	2
7	116087	RCP RADIATOR CUP WASHER	4
8	044129	M10 x 1.5mm NYLOCK NUT	2
9	103425	M10 x 1.5mm STUD BOLT	2
10	330057	BOX MOUNT	1
11	053020	5/16-18 x 1 CARRIAGE BOLT	2
12	056002	1/4-20 x 3/4 HEX SERRATED FLANGE SCREW	1
13	057001	1/4-20 HEX NYLOCK FLANGE NUT	3
14	057008	5/16-18 HEX NYLOCK FLANGE NUT	6
NS	102911	RCP RADIATOR KIT	1

12.2 - Kubota D1005/1105 Engine Fuel Lines

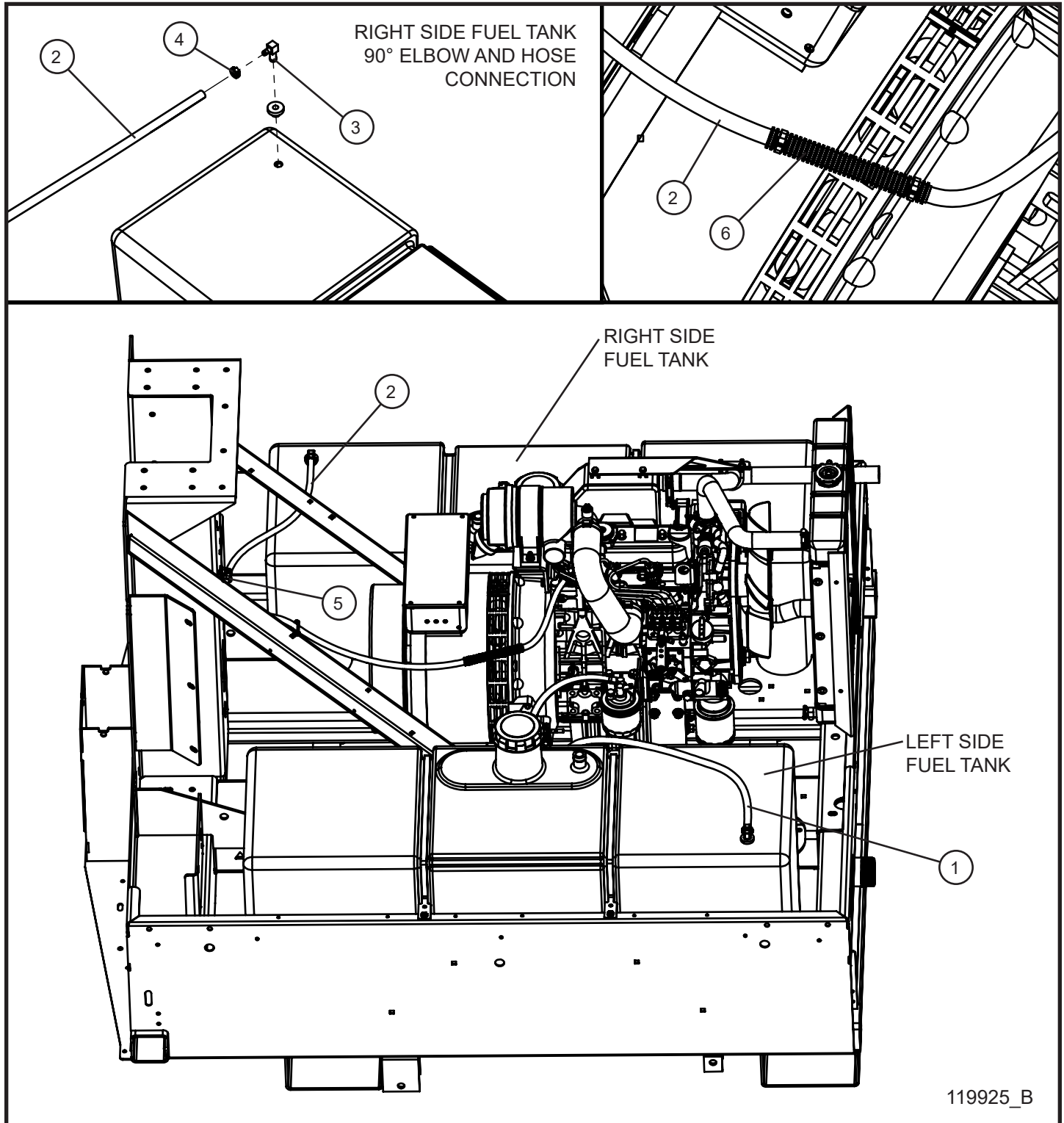

12.2 - Kubota D1005/1105 Engine Fuel Lines

Item	Part No.	Part Description	Qty.
1	081018	HOSE 5/16 FUEL LINE x 35.00	1
2	081016	HOSE 1/4 FUEL LINE X 70.00	1
3	105106	DAPCO 90° ELBOW	1
4	433400	#4 HOSE CLAMP	4
5	022018	#8 CUSH CLAMP	1
	053020	5/16-18 X 1 CARRIAGE BOLT	1
	057006	5/16-18 SERRATED FLANGE NUT	1
6	022205	1/2" SPLIT LOOM X 5.00	1

12.3 - Kubota D1005/1105 Webasto Thermo Top C Heater Lines

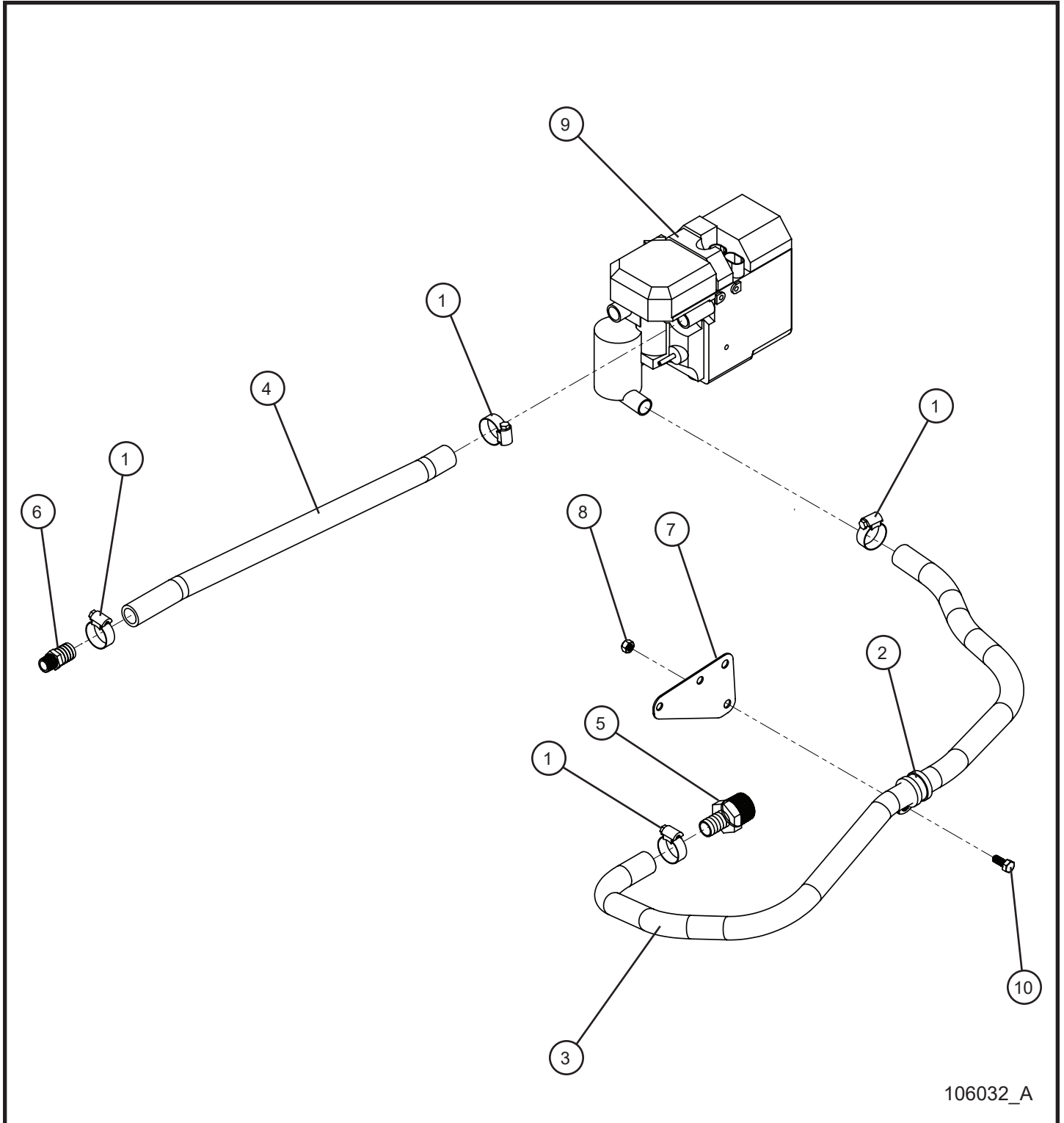

12.3 - Kubota D1005/1105 Webasto Thermo Top C Heater Lines

Item	Part No.	Part Description	Qty.
1	045032	#12 HOSE CLAMP	4
2	022083	#16 CLAMP CUSH 3/8 HOLE	1
3	105016	3/4" HEATER HOSE x 45.0	1
4	105016	3/4" HEATER HOSE x 20.0	1
5	104682	1" NPT - 3/4" BARB FITTING HOSE BARB	1
6	104683	3/8" NPT - 3/4" BARB FITTING HOSE BARB	1
7	106031P	HOSE CLAMP PLATE BLOCK HEATER	1
8	044033	5/16-18 NYLOCK HEX NUT	1
9	104946	WEBASTO TT C DIESEL FIRED COOLANT HEATER KIT	1
10	046045	5/16-18 x 3/4 HEX HEAD BOLT	1

12.4 - Kubota D1005/1105 Webasto Thermo Top EVO Heater Lines

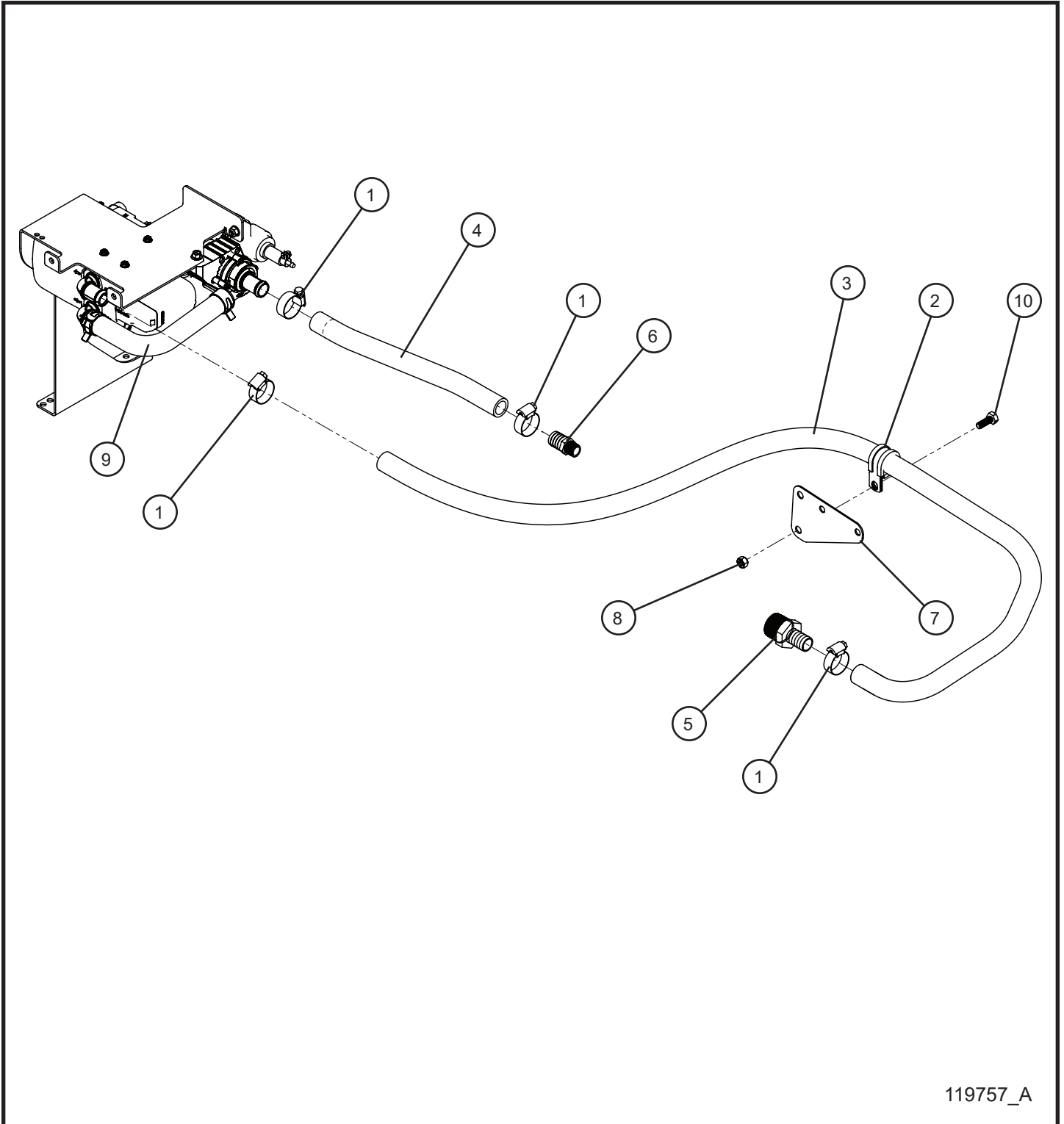

12.4 - Kubota D1005/1105 Webasto Thermo Top EVO Heater Lines

Item	Part No.	Part Description	Qty.
1	045032	#12 HOSE CLAMP	4
2	022083	#16 CLAMP CUSH 3/8 HOLE	1
3	105016	3/4" HEATER HOSE x 45.0	1
4	105016	3/4" HEATER HOSE x 20.0	1
5	104682	1" NPT - 3/4" BARB FITTING HOSE BARB	1
6	104683	3/8" NPT - 3/4" BARB FITTING HOSE BARB	1
7	106031P	HOSE CLAMP PLATE BLOCK HEATER	1
8	044033	5/16-18 NYLOCK HEX NUT	1
9	118278	WEBASTO TT C DIESEL FIRED COOLANT HEATER KIT	1
10	046045	5/16-18 x 3/4 HEX HEAD BOLT	1

12.5 - Kubota D1005/1105 Engine Shocker Group (1 of 2)

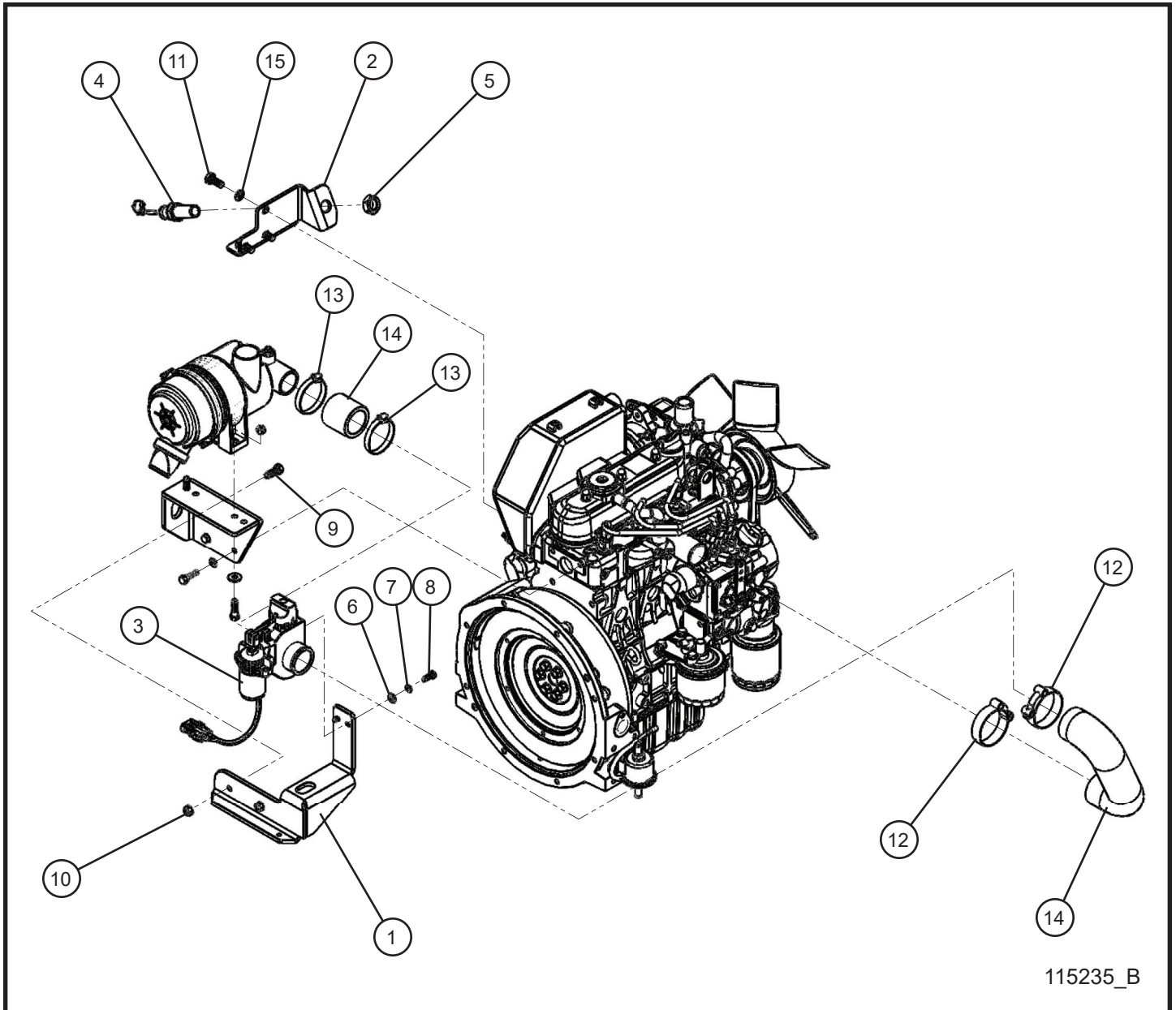

12.5 - Kubota D1005/1105 Engine Shocker Group (1 of 2)

Item	Part No.	Part Description	Qty.
1	105801P	MOUNT SHOCKER VALVE	1
2	106003P	MAG SENSOR KUBOTA BRACKET	1
3	105810	SHOCKER 2" VALVE DELPHI 3 PIN CONNECTOR	1
4	105537	MAGNETIC SENSOR 3/4 x 16 WITH PLUG	1
5	044059	3/4-16 JAM NUT	1
6	047005	1/4 FLAT WASHER	2
7	043020	1/4 SPLITLOCK WASHER	2
8	102573	1/4-20 x 3/4 HEX HEAD BOLT	2
9	046110	3/8-16 x 1 HEX HEAD CS GR5 PL	2
10	044036	3/8-16 KEPS HEX NUT PL	2
11	102130	10MM x 1.25MM x 25MM HEX HEAD BOLT	3
12	105649	2 INCH STAINLESS STEEL T-BOLT CLAMP	2
13	045038	#32 HOSE CLAMP	2
14	101734	AIR INTAKE HOSE SMALL ENGINES	1
15	042151	M10 SPLIT LOCK WASHER	3
NS	105705	SHOCKER 2" VALVE KIT	1
NS	106156	SCHEMATIC SHOCKER VALVE HARNESS	1
NS	105802	HARNESS SHOCKER VALVE	1
NS	105702	SHOCKER SETUP INSTRUCTIONS	1

12.5 - Kubota D1005/1105 Engine Shocker Group (2 of 2)

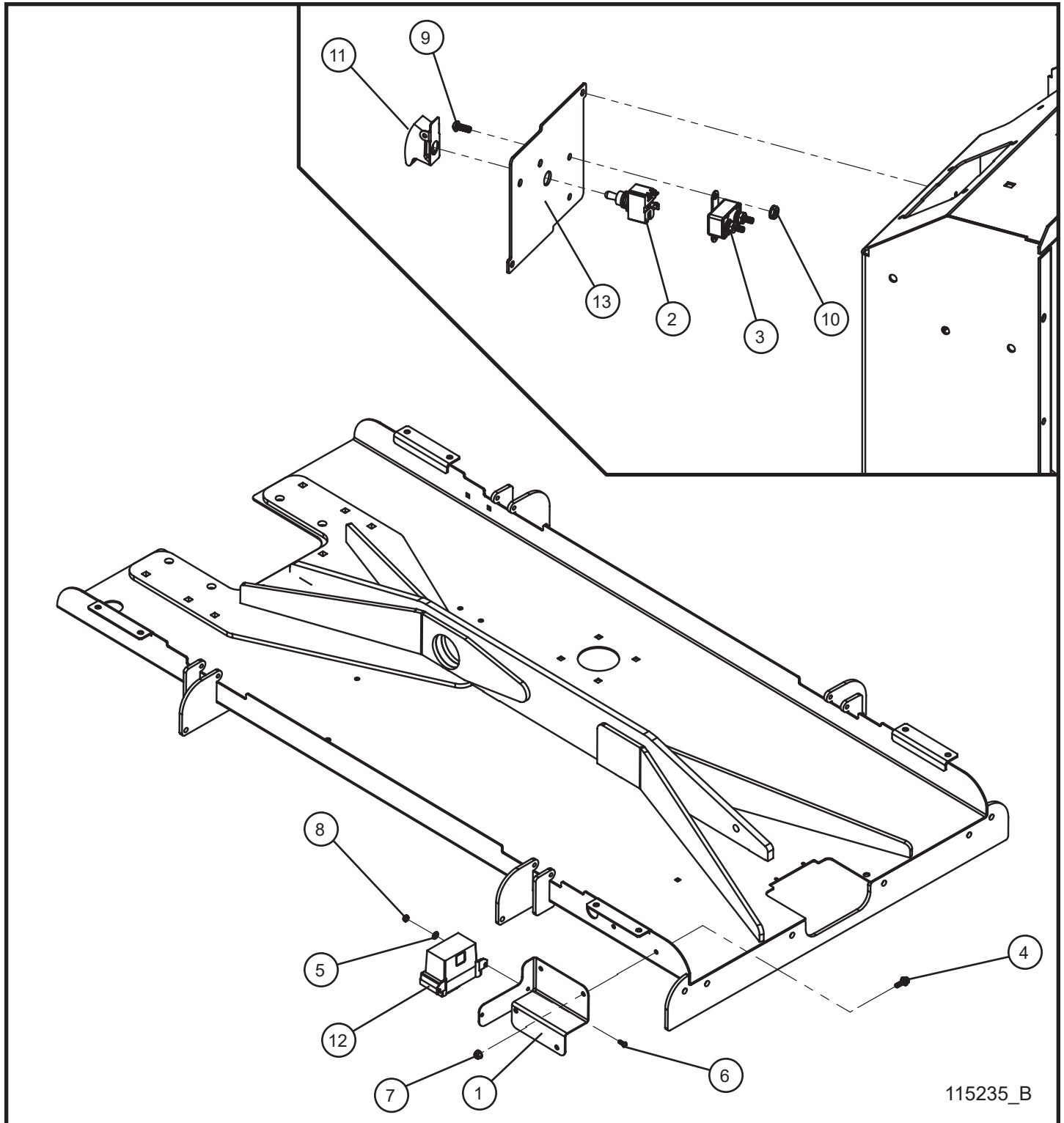

12.5 - Kubota D1005/1105 Engine Shocker Group (2 of 2)

Item	Part No.	Part Description	Qty.
1	113476P	MAXI-LITE SHOCKER CONTROLLER BRACKET	1
2	340009	15A 125V ON/OFF TOGGLE SWITCH	1
3	105636	20 AMP BREAKER	1
4	056002	1/4-20 x 3/4 HEX SERRATED FLANGE SCREW	2
5	047070	#10 FLAT WASHER	2
6	041021	#10-24 x 1/2 PH-ROUND HEAD MACHINE SCREW	2
7	057001	1/4-20 HEX NYLOCK FLANGE NUT	2
8	044018	#10-24 NYLOCK HEX NUT	2
9	041201	#8-32 x 1/2 SL-ROUND HEAD MACHINE SCREW	2
10	044003	#8-32 KEPS HEX NUT	2
11	105645	CONTROLLER PASS TOGGLE SWITCH GUARD	1
12	105692	R5 SHOCKER CONTROLLER	1
13	111228P	MAXI-LITE COMPONENT BOX BACK COVER	1
NS	105705	SHOCKER 2" VALVE KIT	1
NS	106156	SCHEMATIC SHOCKER VALVE HARNESS	1
NS	105802	HARNESS SHOCKER VALVE	1
NS	105702	SHOCKER SETUP INSTRUCTIONS	1

12.6 - Kubota D1005/1105 Engine PacBrake Group

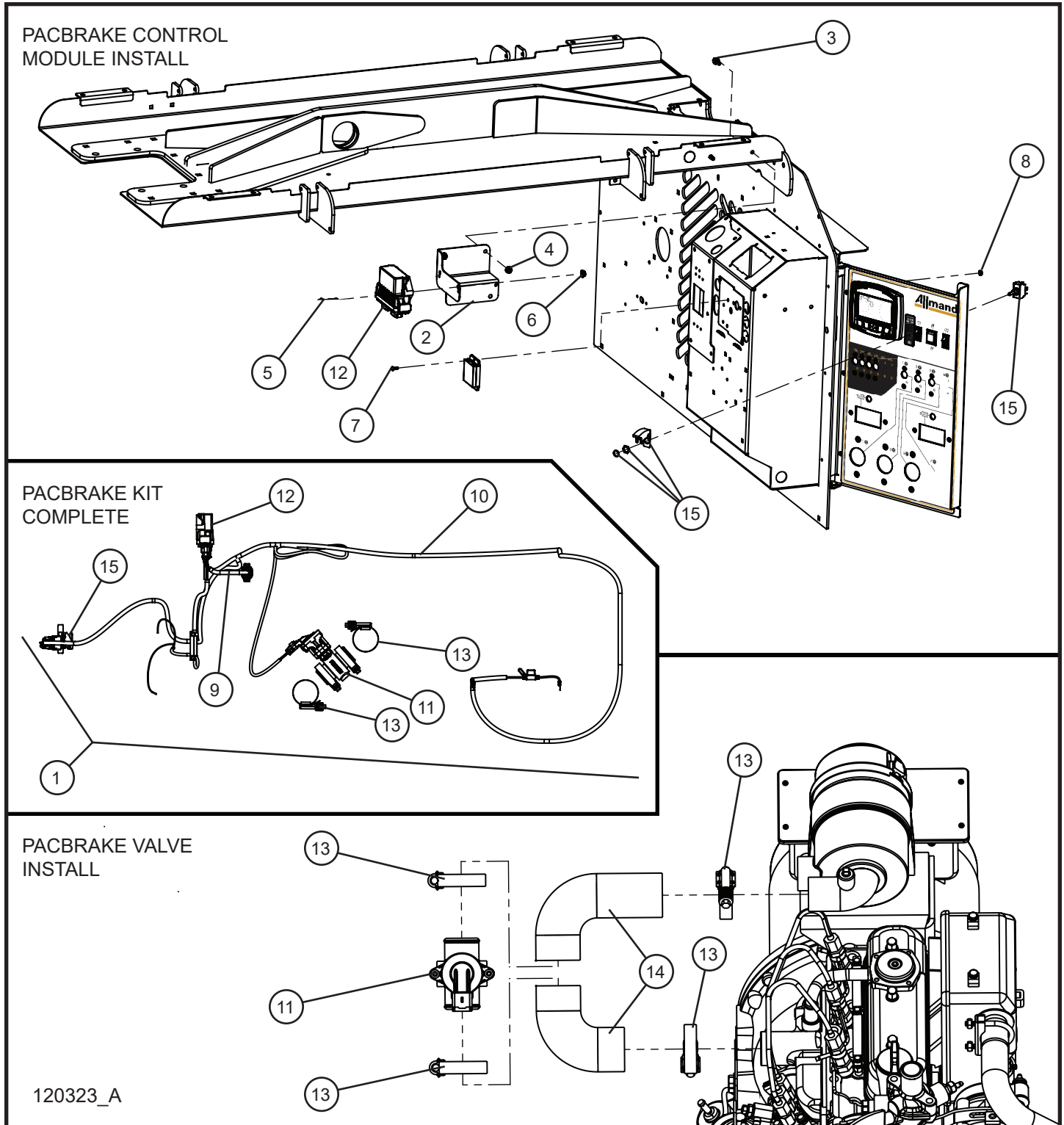

12.6 - Kubota D1005/1105 Engine PacBrake Group

Item	Part No.	Part Description	Qty.
1	118631	PACBRAKE 1.75" AIR INTAKE VALVE KIT COMPLETE MAXI-LITE	1
2	113476P	MAXI-LITE SHOCKER CONTROLLER BRACKET	1
3	056002	1/4-20 X 3/4 HEX SERRATED FLANGE SCREW	2
4	057001	1/4-20 HEX NYLOCK FLANGE NUT	2
5	056012	1/4-20 x 1 1/2 SERRATED FLANGE HEX HEAD SCREW	2
6	057000	1/4-20 HEX SERRATED FLANGE NUT	2
7	041012	#8-32 X 1/2 PL SCREW MS	2
8	044003	#8-32 NC KEPS NUT	2
9	122731	PACBRAKE AC FREQUENCY WIRE HARNESS MAXI-LITE	1
10	122732	PACBRAKE DC WIRE HARNESS MAXI-LITE	1
11	122735	PACBRAKE 1.75" AIR INTAKE VALVE	1
12	122736	PACBRAKE AIR INTAKE VALVE CONTROL MODULE	1
13	122737	PACBRAKE SAE 262 BAND CLAMP	4
14	101734	AIR INTAKE HOSE SMALL ENGINES	1
15	122739	PACBRAKE TOGGLE SWITCH KIT	1
NS	103864	FUSE HOLDER INLINE BLADE	1
NS	104990	FUSE BLADE 2 AMP ATO/ATC	1
NS	105844	15 AMP MINI FUSE	1
NS	117814	WIRE SCHEMATIC PACBRAKE AIR VALVE	1

NS - Not Shown

* * * - Contact Allmand for more information.

12.7 - Kubota D1005/1105 Engine Exhaust Blanket

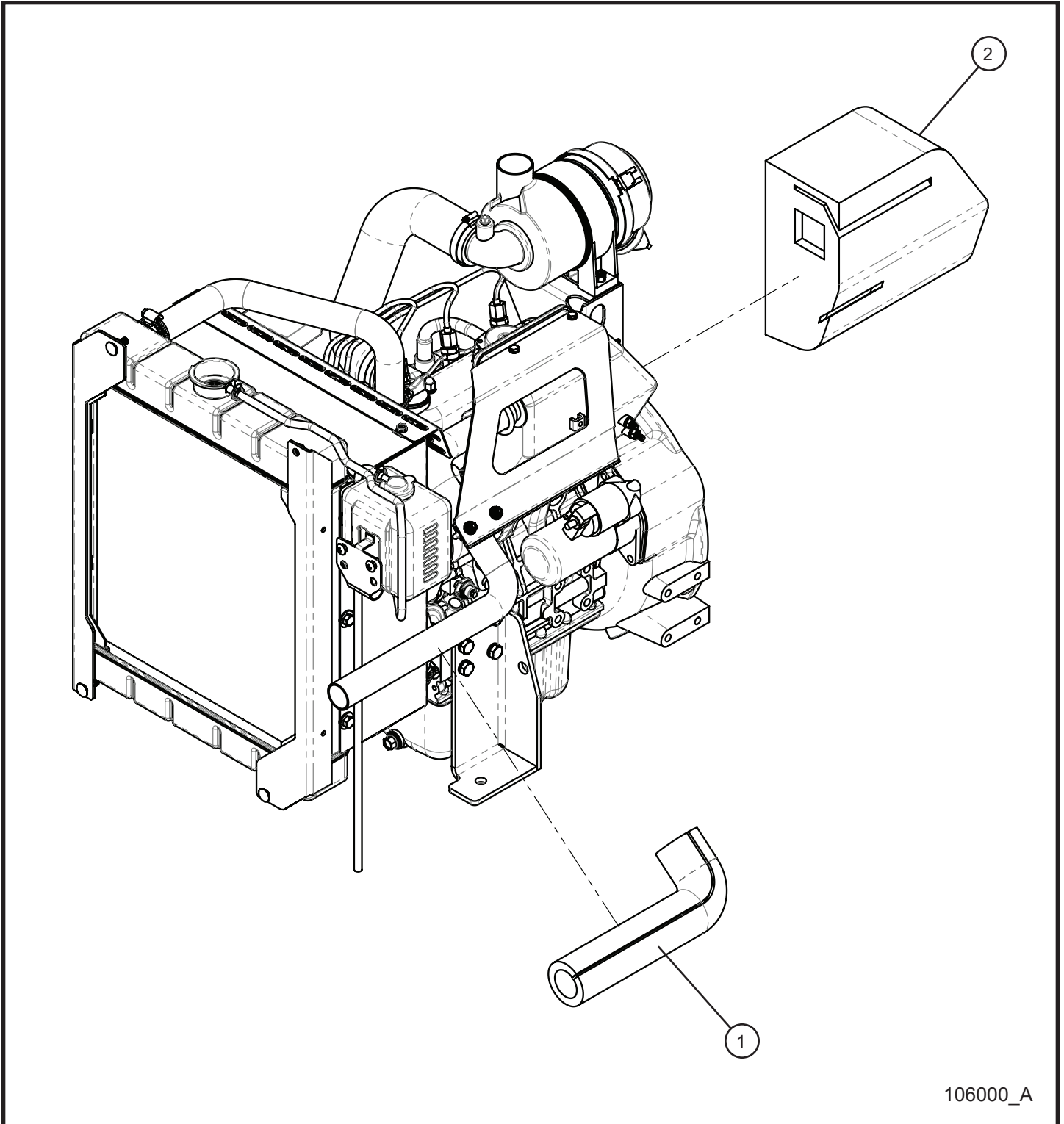

106000_A

12.7 - Kubota D1005/1105 Engine Exhaust Blanket

Item	Part No.	Part Description	Qty.
1	105994	BLANKET INSULATING TAIL PIPE	1
2	103460	BLANKET INSULATING BOX MUFFLER	1

12.8 - Kubota D1005/1105 Vertical Exhaust Pipe Option I

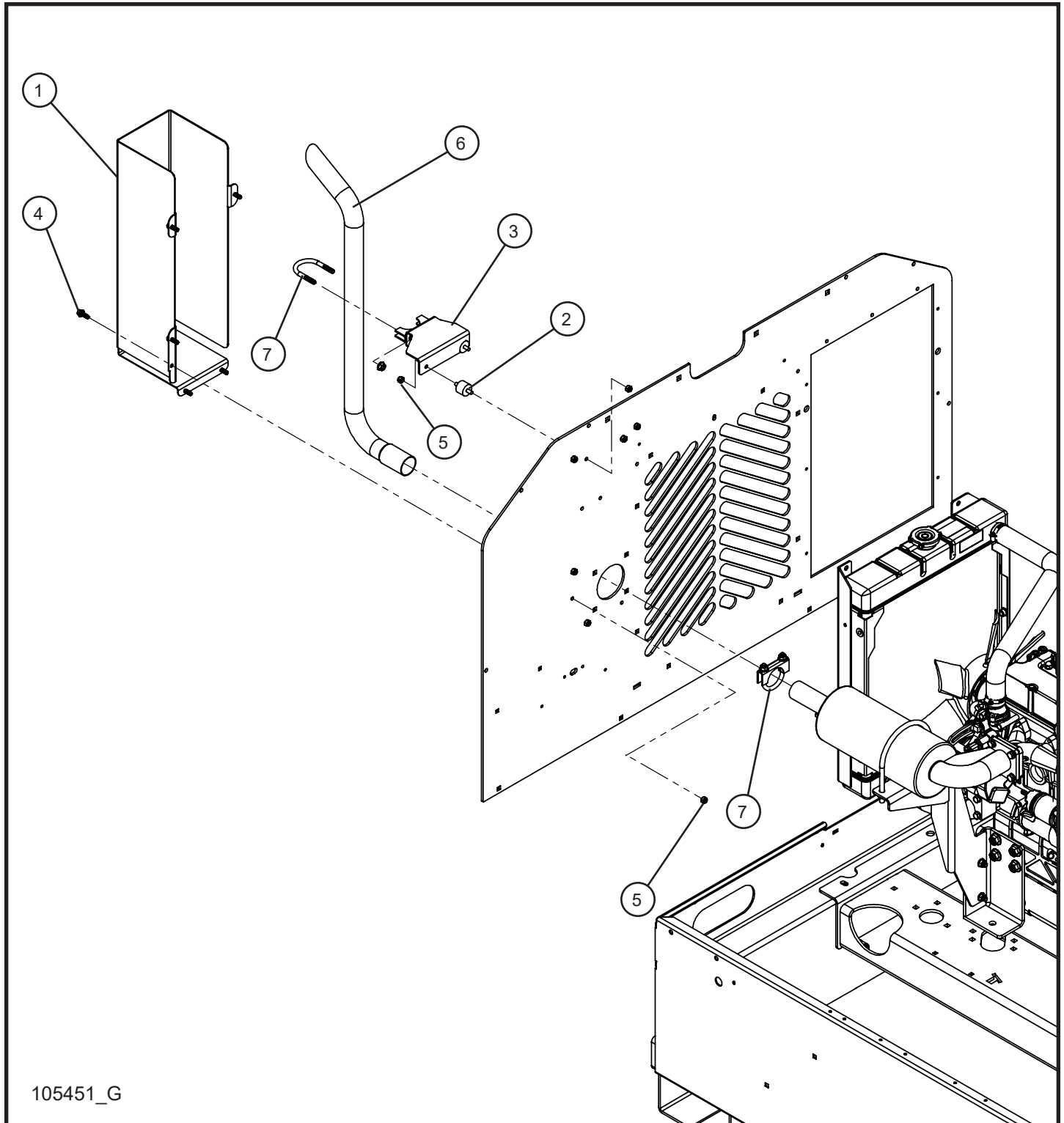

105451_G

12.8 - Kubota D1005/1105 Vertical Exhaust Pipe Option I

Item	Part No.	Part Description	Qty.
1	105034P	TAILPIPE SHIELD REAR/VERTICAL EXIT	1
2	330057	BOX MOUNT RUBBER	2
3	105454P	BRACKET SUPPORT VERTICAL EXHAUST	1
4	056002	1/4-20 X 3/4 HEX SERRATED FLANGE SCREW	6
5	044023	1/4-20 NYLOCK HEX NUT PL	10
6	105452	EXHAUST ELBOW VERTICAL 1.375" OD	1
7	713086	MUFFLER CLAMP 1-3/8	2

NS - Not Shown

* * * - Contact Allmand for more information.

12.9 - Kubota D1005/1105 Vertical Exhaust Pipe Option II

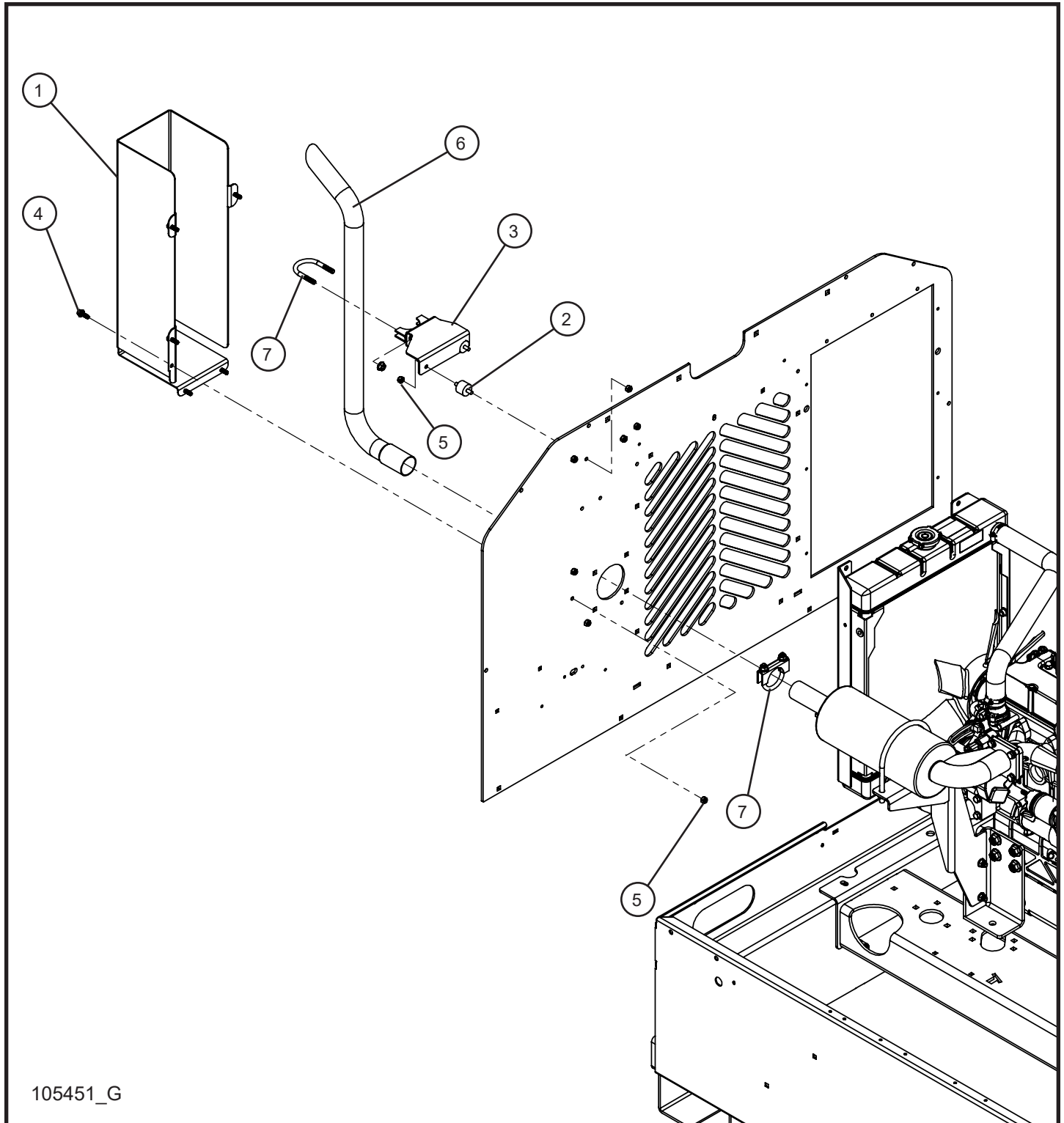

105451_G

12.9 - Kubota D1005/1105 Vertical Exhaust Pipe Option II

Item	Part No.	Part Description	Qty.
1	105034P	TAILPIPE SHIELD REAR/VERTICAL EXIT	1
2	330057	BOX MOUNT RUBBER	2
3	105454P	BRACKET SUPPORT VERTICAL EXHAUST	1
4	056002	1/4-20 X 3/4 HEX SERRATED FLANGE SCREW	6
5	044023	1/4-20 NYLOCK HEX NUT PL	10
6	105450	EXHAUST ELBOW VERTICAL 1.5" OD	1
7	112211	1-5/8 MUFFLER CLAMP EXHAUST	2

NS - Not Shown

* * * - Contact Allmand for more information.

13.1 - Isuzu 4LE2T Engine DSE 4520 Assembly Group (1 of 4)

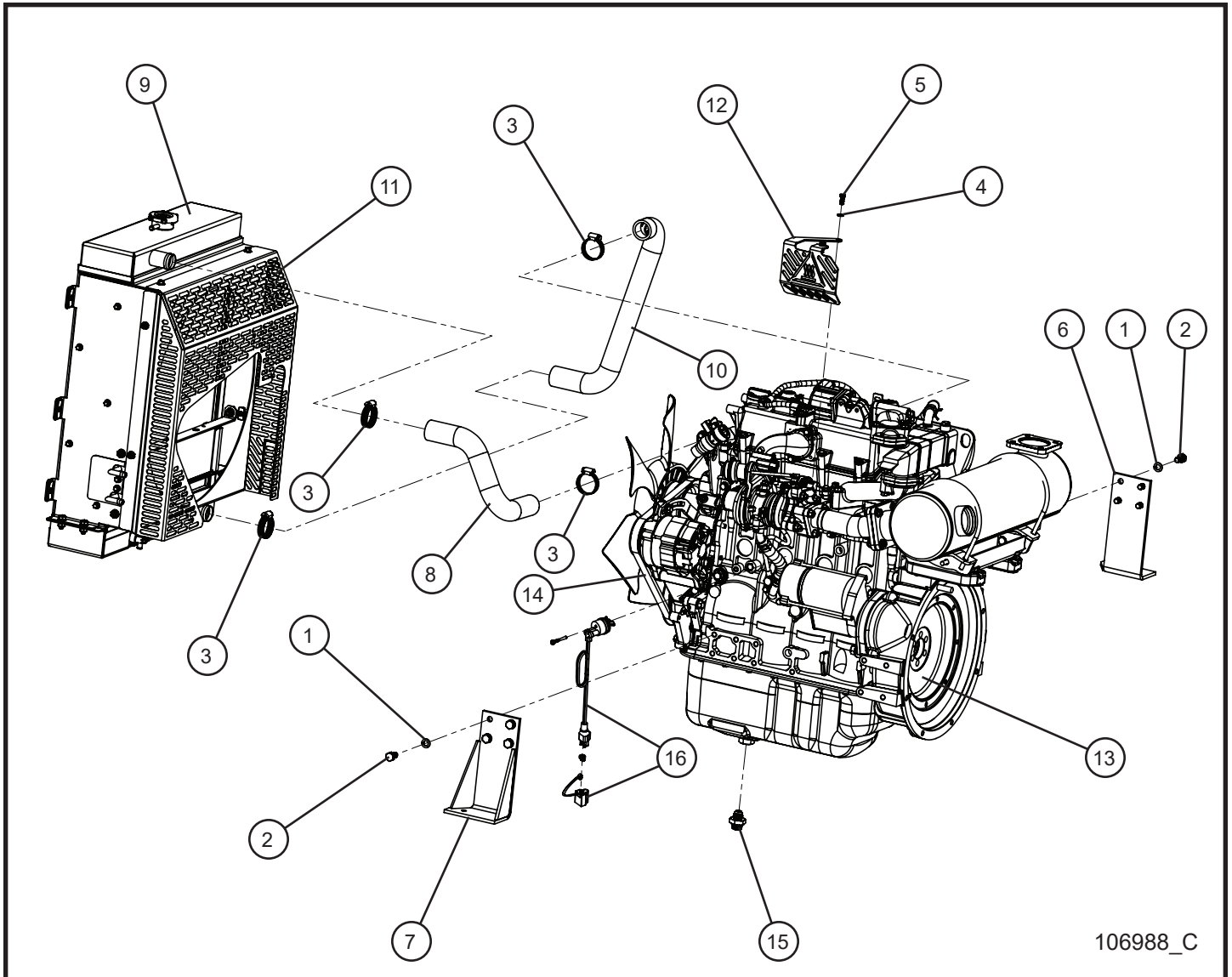

13.1 - Isuzu 4LE2T Engine DSE 4520 Assembly Group (1 of 4)

Item	Part No.	Part Description	Qty.
1	042151	M10 SPLITLOCK WASHER	8
2	042037	M10 x 20mm x 1.5mm HEX HEAD BOLT	8
3	045035	#20 HOSE CLAMP	4
4	043020	1/4 SPLITLOCK WASHER	2
5	042019	M6 x 16mm x 1.0mm HEX HEAD BOLT	2
6	107004P	ISUZU 4LE2T LEFT ENGINE MOUNT	1
7	107002P	ISUZU 4LE2T RIGHT ENGINE MOUNT	1
8	106986	ISUZU 4LE2T UPPER RADIATOR HOSE	1
9	106983	ISUZU 4LE2T RADIATOR	1
10	106985	ISUZU 4LE2T LOWER RADIATOR HOSE	1
11	107005P	ISUZU 4LE2T FINGER GUARD	1
12	107012P	ISUZU 4LE2T TURBO GUARD	1
13	109990	ISUZU 4LEST 60Hz T4F ENGINE	1
14	111649	FAN BELT	1
15	106989	JIC-10 to M24 x 2 FITTING W/ SEALING WASHER	1
16	352469	35mm BLOCK HEATER 400W / 120V	1
NS	111647	MAIN FUEL FILTER	1
NS	111648	PRE FUEL FILTER	1
NS	113008	ELECTRIC FUEL PUMP	1
NS	107927	HARNESS ISUZU 4LE2T T4F DSE 4520 MK II	1

13.1 - Isuzu 4LE2T Engine DSE 4520 Assembly Group (2 of 4)

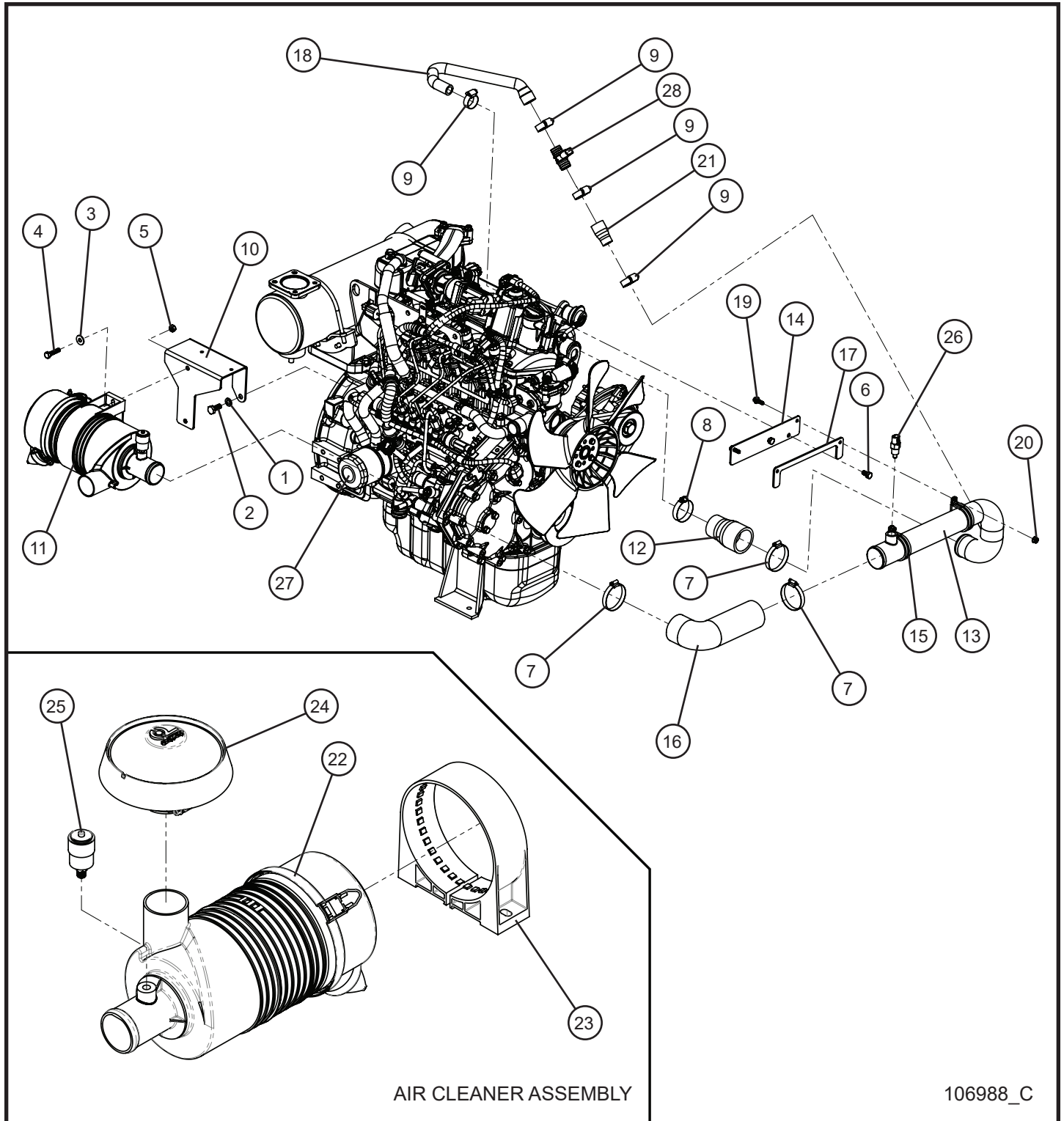

106988_C

13.1 - Isuzu 4LE2T Engine DSE 4520 Assembly Group (2 of 4)

Item	Part No.	Part Description	Qty.
1	042151	M10 SPLITLOCK WASHER	10
2	102130	M10 x 25mm x 1.25mm HEX HEAD BOLT	2
3	047010	5/16 FLAT WASHER	2
4	102127	M8 x 35mm x 1.25mm HEX HEAD BOLT	2
5	042081	M8 x 1.25mm NYLOCK HEX NUT	2
6	042027	M8 x 16mm x 1.25mm HEX HEAD BOLT	2
7	045038	#32 HOSE CLAMP	3
8	045036	#24 HOSE CLAMP	1
9	045032	#12 HOSE CLAMP	4
10	106996P	ISUZU 4LE2T AIR CLEANER BRACKET	1
11	106072	AIR CLEANER ASSEMBLY	1
12	106987	2.00 to 1.50 ISUZU 4LE2T AIR INTAKE ADAPTER	1
13	106254	ISUZU 4LE2T STEEL TUBE AIR INTAKE	1
14	107009P	ISUZU 4LE2T INTAKE SUPPORT BRACKET	1
15	022008	#32 CUSHION CLAMP 1/4 HOLE	2
16	106673	ISUZU 4LE2T 90° INTAKE HOSE ELBOW	1
17	107011P	ISUZU 4LE2T INTAKE SUPPORT SPACER	1
18	107117	ISUZU 4LE2T PCV HOSE	1
19	056002	1/4-20 x 3/4 HEX SERRATED FLANGE SCREW	8
20	057001	1/4-20 HEX NYLOCK FLANGE NUT	4
21	107121	ISUZU 4LE2T PCV HOSE REDUCER	1
22	104061	DONALDSON AIR CLEANER ASSEMBLY	1
	15-000125	PRIMARY AIR FILTER	1
	104071	SAFETY FILTER	1
23	921140	AIR CLEANER BAND MOUNT	1
24	340032	AIR CLEANER 2" ID CAP	1
25	104795	AIR FILTER SERVICE INDICATOR KIT	1
26	N/A	AIR TEMPERATURE SENDER	1
27	650221	OIL FILTER	
28	106943	HEATER PCV	1

13.1 - Isuzu 4LE2T Engine DSE 4520 Assembly Group (3 of 4)

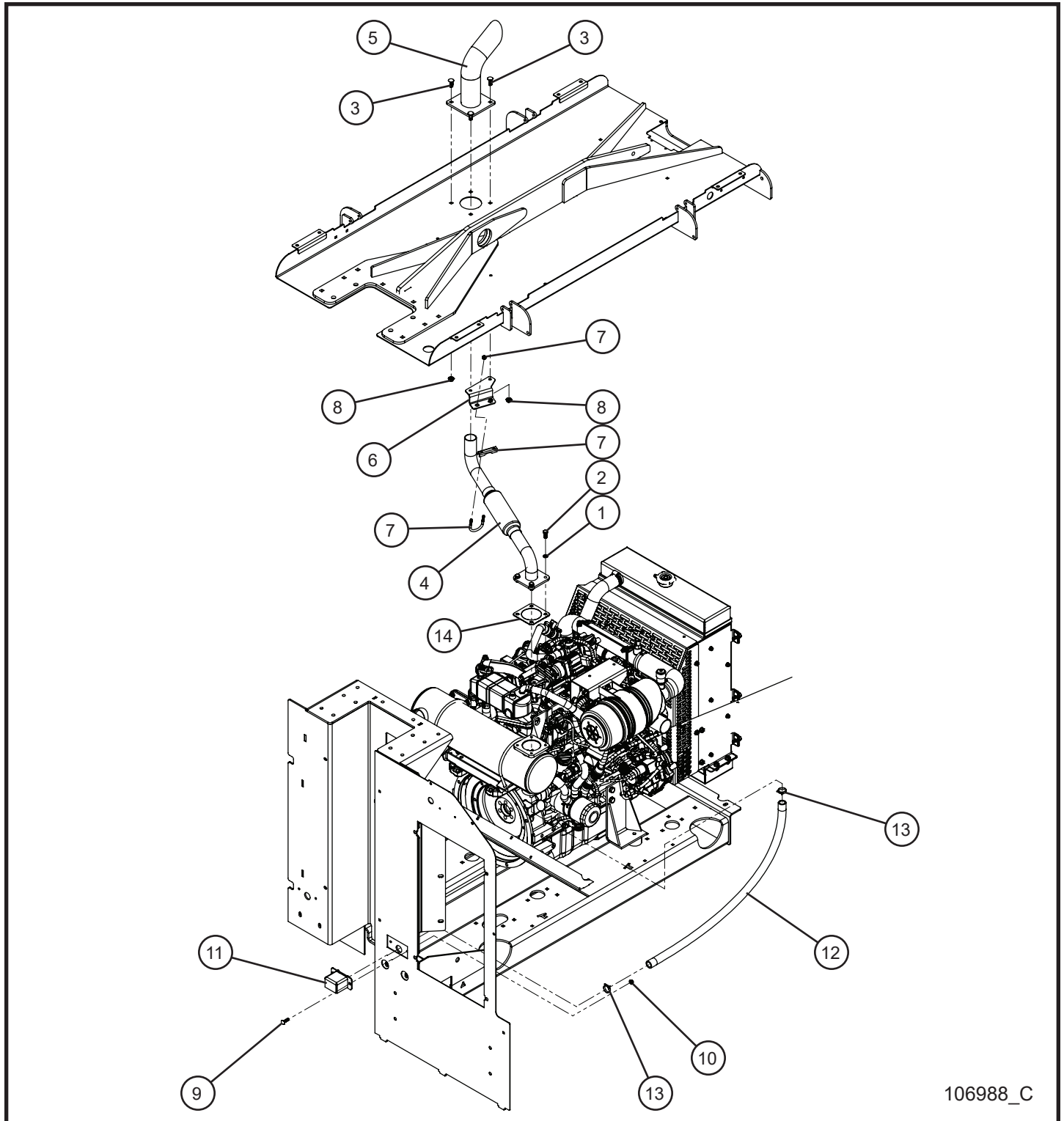

106988_C

13.1 - Isuzu 4LE2T Engine DSE 4520 Assembly Group (3 of 4)

Item	Part No.	Part Description	Qty.
1	043055	5/16 SPLITLOCK WASHER	10
2	042033	M8 x 20mm x 1.25mm HEX HEAD BOLT	4
3	053020	5/16-18 x 1 CARRIAGE BOLT	4
4	107125	ISUZU 4LE2T EXHAUST	1
5	107124	EXHAUST STACK	1
6	113477P	ISUZU 4LE2T EXHAUST CLAMP MOUNT	1
7	713086	1-3/8 MUFFLER CLAMP	1
8	057006	5/16-18 SERRATED FLANGE NUT	4
9	100342	1/4-20 x 1 CARRIAGE BOLT	2
10	057001	1/4-20 HEX NYLOCK FLANGE NUT	4
11	108894P	ISUZU 4LE2T SECONDARY EXHAUST GUARD	1
12	082000	7/16 PTFE TUBING x 31.0	1
13	045100	7.5 STSF SILVER CONSTANT TENSION CLAMP	2
14	N/A	EXHAUST FLANGE GASKET	1

13.1 - Isuzu 4LE2T Engine DSE 4520 Assembly Group (4 of 4)

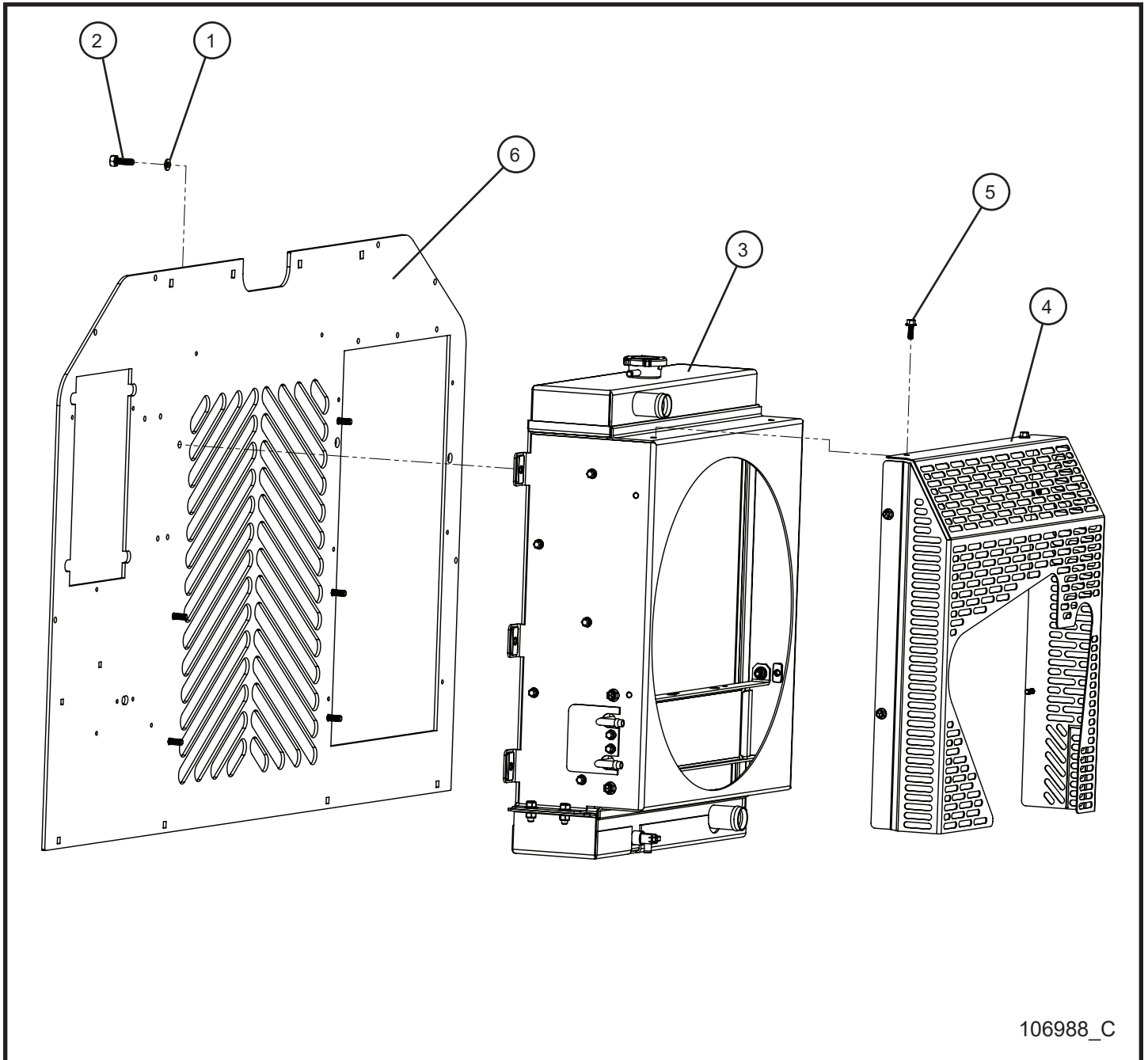

13.1 - Isuzu 4LE2T Engine DSE 4520 Assembly Group (4 of 4)

Item	Part No.	Part Description	Qty.
1	043055	5/16 SPLITLOCK WASHER	6
2	046050	5/16-18 x 1 HEX HEAD BOLT	6
3	106983	ISUZU 4LE2T RADIATOR	1
4	107005P	ISUZU 4LE2T FINGER GUARD	1
5	056002	1/4-20 x 3/4 HEX SERRATED FLANGE SCREW	8
6	107010P	ISUZU 4LE2T REAR PANEL	1

13.2 - Isuzu 4LE2T Engine DSE L401 Assembly Group (1 of 4)

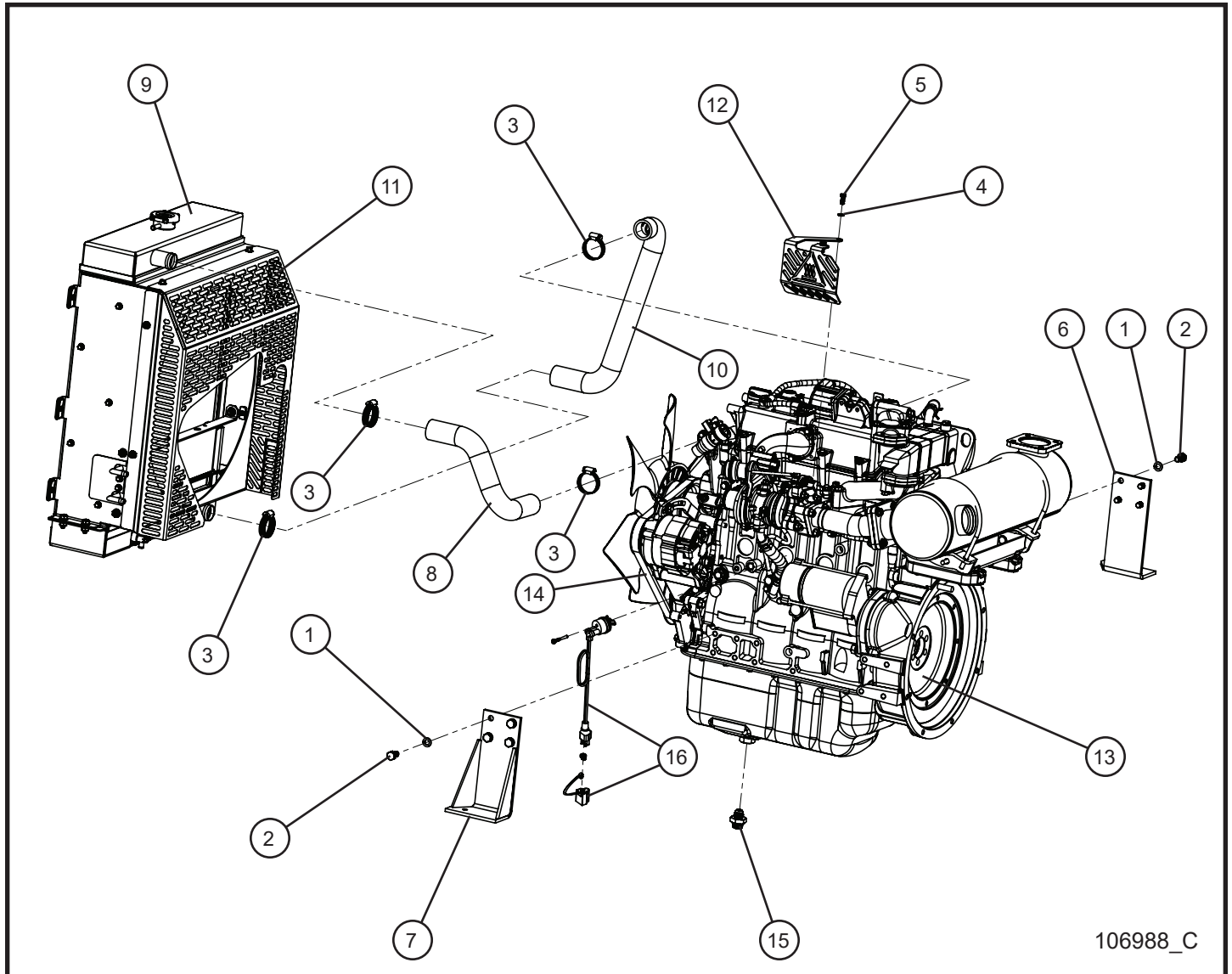

13.2 - Isuzu 4LE2T Engine DSE L401 Assembly Group (1 of 4)

Item	Part No.	Part Description	Qty.
1	042151	M10 SPLITLOCK WASHER	8
2	042037	M10 x 20mm x 1.5mm HEX HEAD BOLT	8
3	045035	#20 HOSE CLAMP	4
4	043020	1/4 SPLITLOCK WASHER	2
5	042019	M6 x 16mm x 1.0mm HEX HEAD BOLT	2
6	107004P	ISUZU 4LE2T LEFT ENGINE MOUNT	1
7	107002P	ISUZU 4LE2T RIGHT ENGINE MOUNT	1
8	106986	ISUZU 4LE2T UPPER RADIATOR HOSE	1
9	106983	ISUZU 4LE2T RADIATOR	1
10	106985	ISUZU 4LE2T LOWER RADIATOR HOSE	1
11	107005P	ISUZU 4LE2T FINGER GUARD	1
12	107012P	ISUZU 4LE2T TURBO GUARD	1
13	109990	ISUZU 4LE2T 60Hz T4F ENGINE	1
14	111649	FAN BELT	1
15	106989	JIC-10 to M24 x 2 FITTING W/ SEALING WASHER	1
16	352469	35mm BLOCK HEATER 400W / 120V	1
NS	111647	MAIN FUEL FILTER	1
NS	111648	PRE FUEL FILTER	1
NS	113008	ELECTRIC FUEL PUMP	1
NS	116064	ISUZU 4LE2T HARNESS DSE L401 MK II	1

13.2 - Isuzu 4LE2T Engine DSE L401 Assembly Group (2 of 4)

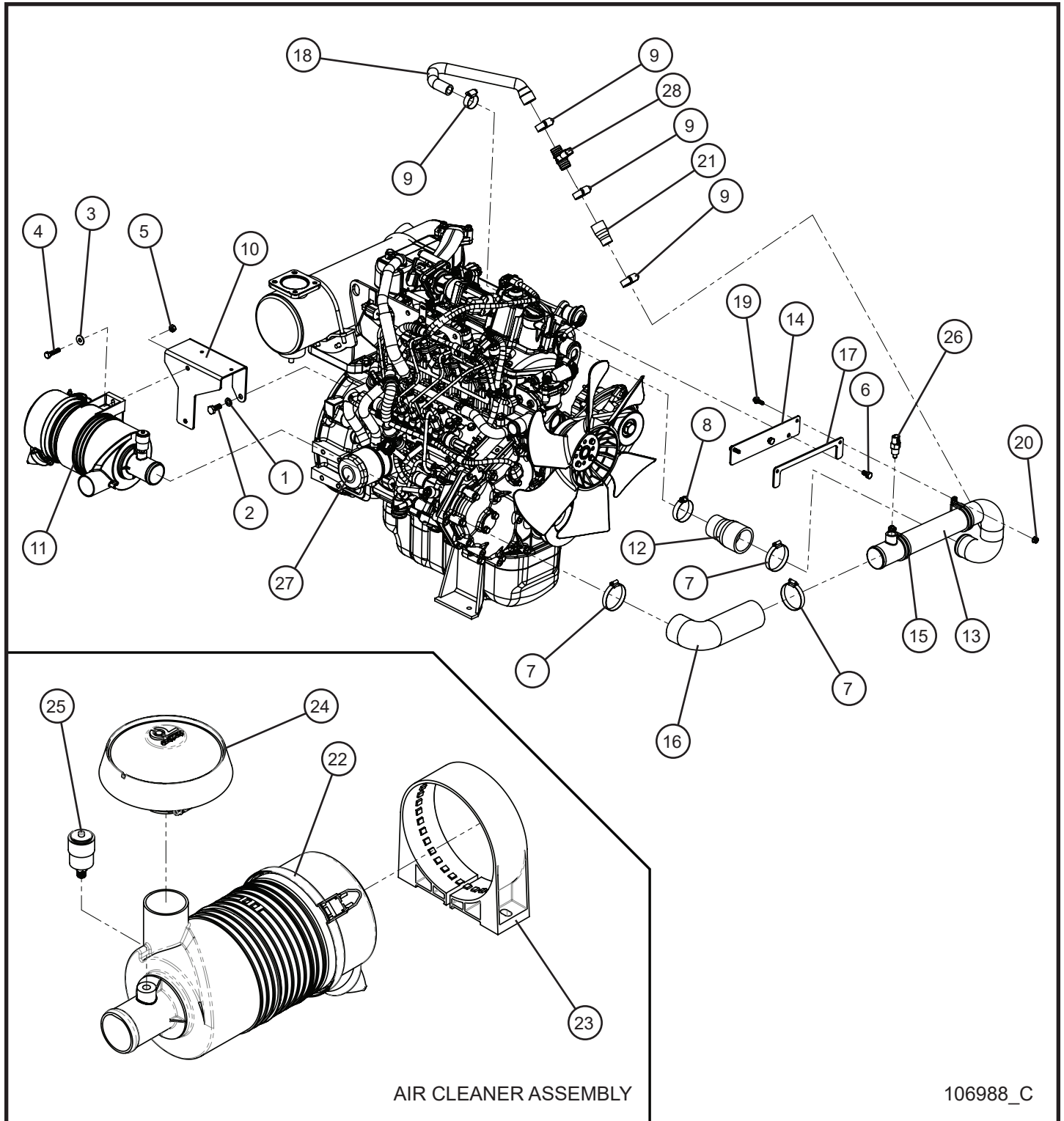

106988_C

13.2 - Isuzu 4LE2T Engine DSE L401 Assembly Group (2 of 4)

Item	Part No.	Part Description	Qty.
1	042151	M10 SPLITLOCK WASHER	10
2	102130	M10 x 25mm x 1.25mm HEX HEAD BOLT	2
3	047010	5/16 FLAT WASHER	2
4	102127	M8 x 35mm x 1.25mm HEX HEAD BOLT	2
5	042081	M8 x 1.25mm NYLOCK HEX NUT	2
6	042027	M8 x 16mm x 1.25mm HEX HEAD BOLT	2
7	045038	#32 HOSE CLAMP	3
8	045036	#24 HOSE CLAMP	1
9	045032	#12 HOSE CLAMP	4
10	106996P	ISUZU 4LE2T AIR CLEANER BRACKET	1
11	106072	AIR CLEANER ASSEMBLY	1
12	106987	2.00 to 1.50 ISUZU 4LE2T AIR INTAKE ADAPTER	1
13	106254	ISUZU 4LE2T STEEL TUBE AIR INTAKE	1
14	107009P	ISUZU 4LE2T INTAKE SUPPORT BRACKET	1
15	022008	#32 CUSHION CLAMP 1/4 HOLE	2
16	106673	ISUZU 4LE2T 90° INTAKE HOSE ELBOW	1
17	107011P	ISUZU 4LE2T INTAKE SUPPORT SPACER	1
18	107117	ISUZU 4LE2T PCV HOSE	1
19	056002	1/4-20 x 3/4 HEX SERRATED FLANGE SCREW	8
20	057001	1/4-20 HEX NYLOCK FLANGE NUT	4
21	107121	ISUZU 4LE2T PCV HOSE REDUCER	1
22	104061	DONALDSON AIR CLEANER ASSEMBLY	1
	15-000125	PRIMARY FILTER	1
	104071	SAFETY FILTER	1
23	921140	AIR CLEANER BAND MOUNT	1
24	340032	AIR CLEANER 2" ID CAP	1
25	104795	AIR FILTER SERVICE INDICATOR KIT	1
26	***	AIR TEMPERATURE SENDER	1
27	650221	OIL FILTER	1
28	106943	HEATER PCV	1

NS - Not Shown

*** - Contact Allmand for more information.

13.2 - Isuzu 4LE2T Engine DSE L401 Assembly Group (3 of 4)

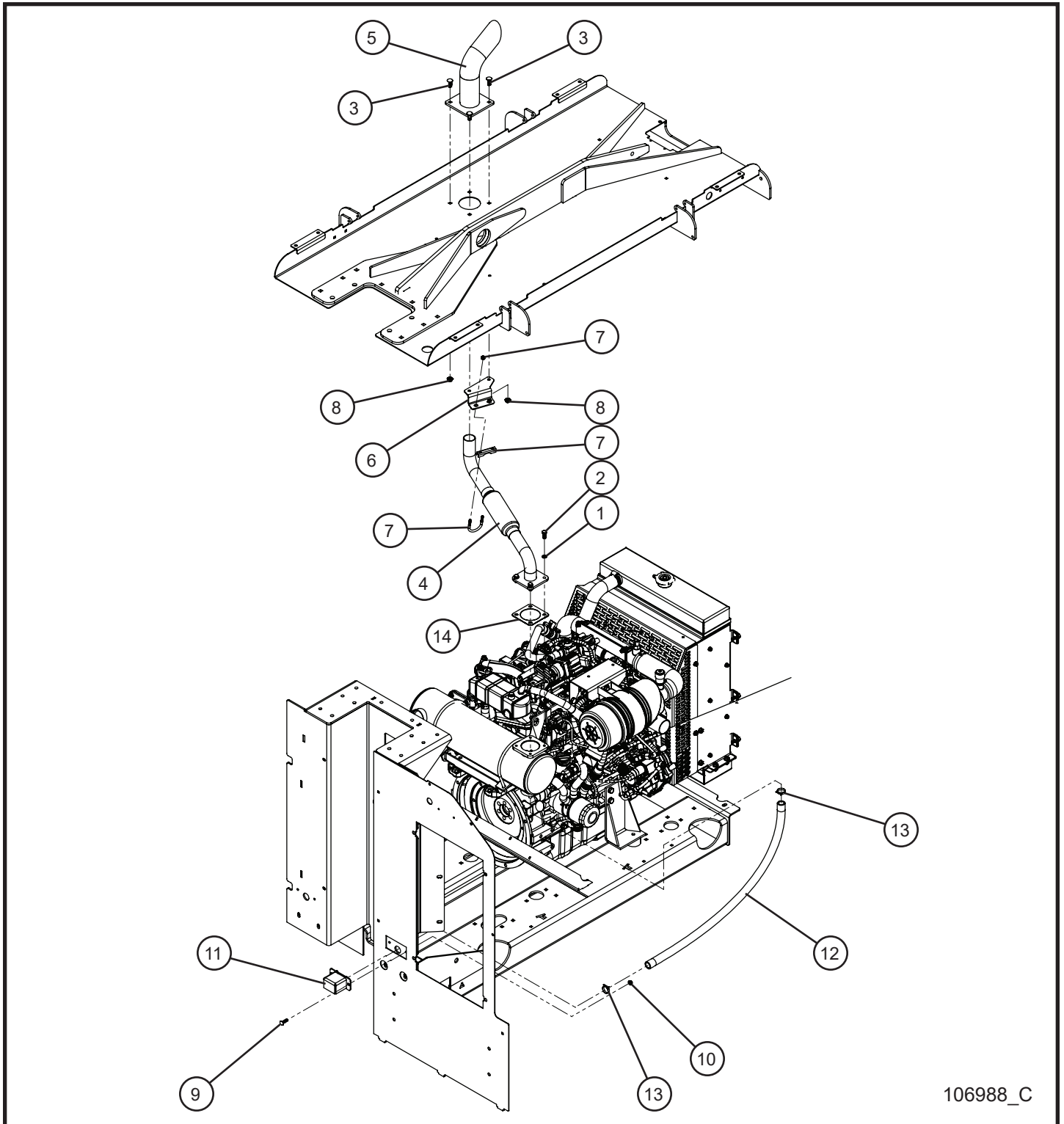

106988_C

13.2 - Isuzu 4LE2T Engine DSE L401 Assembly Group (3 of 4)

Item	Part No.	Part Description	Qty.
1	043055	5/16 SPLITLOCK WASHER	10
2	042033	M8 x 20mm x 1.25mm HEX HEAD BOLT	4
3	053020	5/16-18 x 1 CARRIAGE BOLT	4
4	107125	ISUZU 4LE2T EXHAUST	1
5	107124	EXHAUST STACK	1
6	113477P	ISUZU 4LE2T EXHAUST CLAMP MOUNT	1
7	713086	1-3/8 MUFFLER CLAMP	1
8	057006	5/16-18 SERRATED FLANGE NUT	4
9	100342	1/4-20 x 1 CARRIAGE BOLT	2
10	057001	1/4-20 HEX NYLOCK FLANGE NUT	4
11	108894P	ISUZU 4LE2T SECONDARY EXHAUST GUARD	1
12	082000	7/16 PTFE TUBING x 31.0	1
13	045100	7.5 STSF SILVER CONSTANT TENSION CLAMP	2
14	N/A	EXHAUST FLANGE GASKET	1

13.2 - Isuzu 4LE2T Engine DSE L401 Assembly Group (4 of 4)

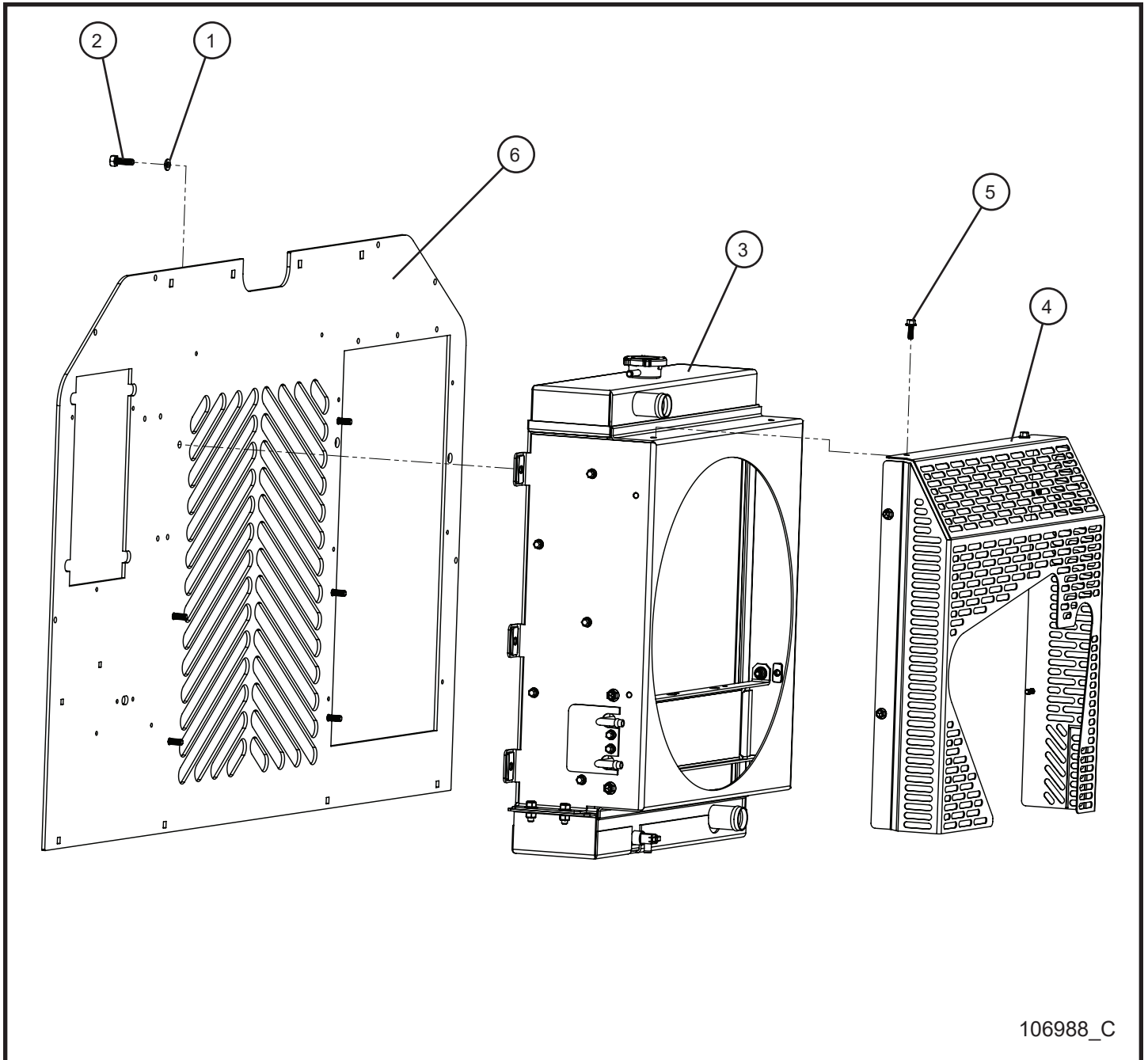

13.2 - Isuzu 4LE2T Engine DSE L401 Assembly Group (4 of 4)

Item	Part No.	Part Description	Qty.
1	043055	5/16 SPLITLOCK WASHER	6
2	046050	5/16-18 x 1 HEX HEAD BOLT	6
3	106983	ISUZU 4LE2T RADIATOR	1
4	107005P	ISUZU 4LE2T FINGER GUARD	1
5	056002	1/4-20 x 3/4 HEX SERRATED FLANGE SCREW	8
6	107010P	ISUZU 4LE2T REAR PANEL	1

13.3 - Isuzu 4LE2T Engine DSE L401 Assembly Group II (1 of 4)

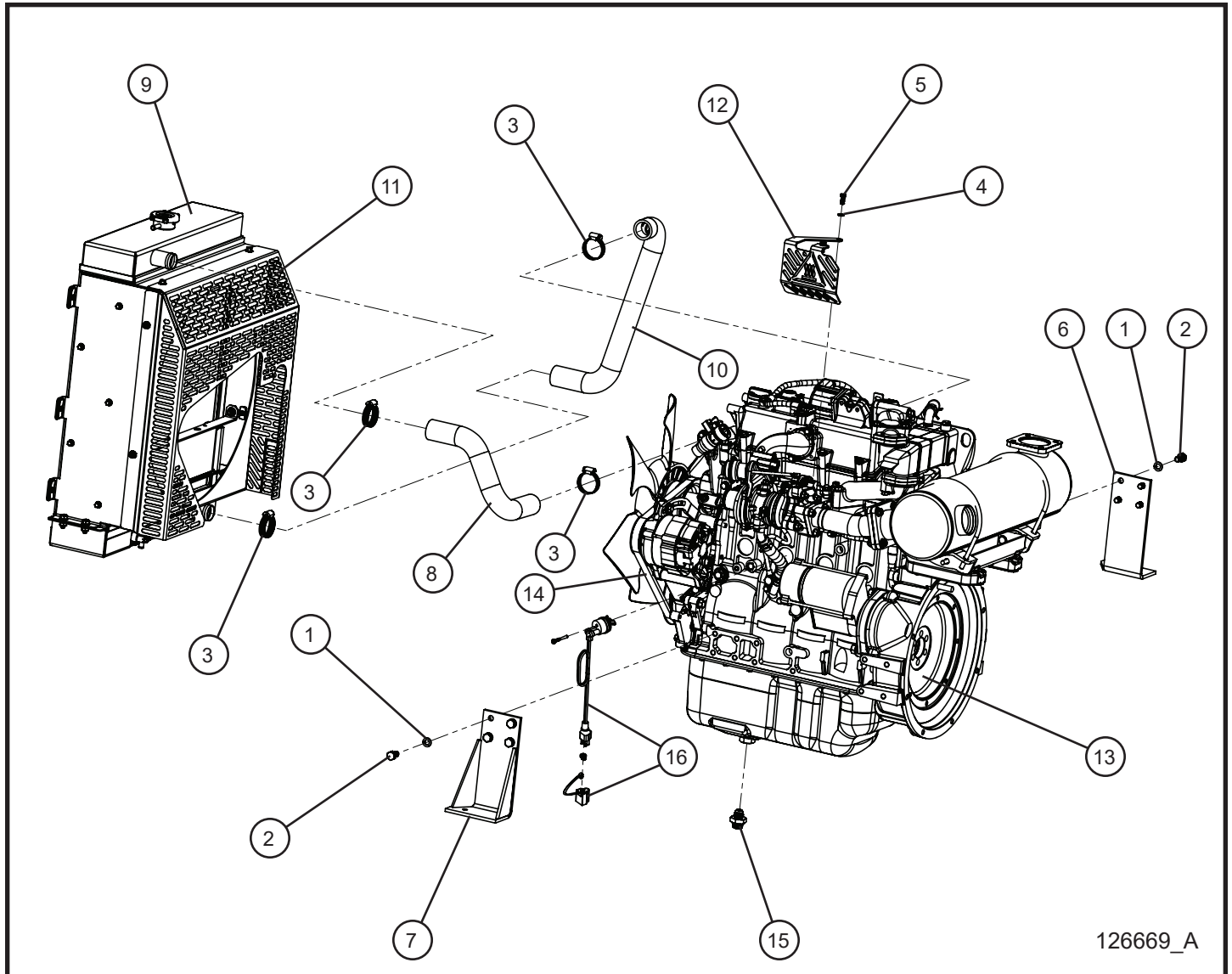

13.3 - Isuzu 4LE2T Engine DSE L401 Assembly Group II (1 of 4)

Item	Part No.	Part Description	Qty.
1	042151	M10 SPLITLOCK WASHER	8
2	042037	M10 x 20mm x 1.5mm HEX HEAD BOLT	8
3	045035	#20 HOSE CLAMP	4
4	043020	1/4 SPLITLOCK WASHER	2
5	042019	M6 x 16mm x 1.0mm HEX HEAD BOLT	2
6	107004P	ISUZU 4LE2T LEFT ENGINE MOUNT	1
7	107002P	ISUZU 4LE2T RIGHT ENGINE MOUNT	1
8	106986	ISUZU 4LE2T UPPER RADIATOR HOSE	1
9	125586	ISUZU 4LE2T RADIATOR SHORT SHROUD	1
10	106985	ISUZU 4LE2T LOWER RADIATOR HOSE	1
11	126667P	ISUZU 4LE2T FINGER GUARD SHORT SHROUD MAXI-LITE	1
12	107012P	ISUZU 4LE2T TURBO GUARD	1
13	122011	ISUZU 4LE2T ENGINE MP SPEC	1
14	111649	FAN BELT	1
15	106989	JIC-10 to M24 x 2 FITTING W/ SEALING WASHER	1
16	352469	35mm BLOCK HEATER 400W / 120V	1
NS	111647	MAIN FUEL FILTER	1
NS	111648	PRE FUEL FILTER	1
NS	113008	ELECTRIC FUEL PUMP	1
NS	116064	ISUZU 4LE2T HARNESS DSE L401 MK II	1

13.3 - Isuzu 4LE2T Engine DSE L401 Assembly Group II (2 of 4)

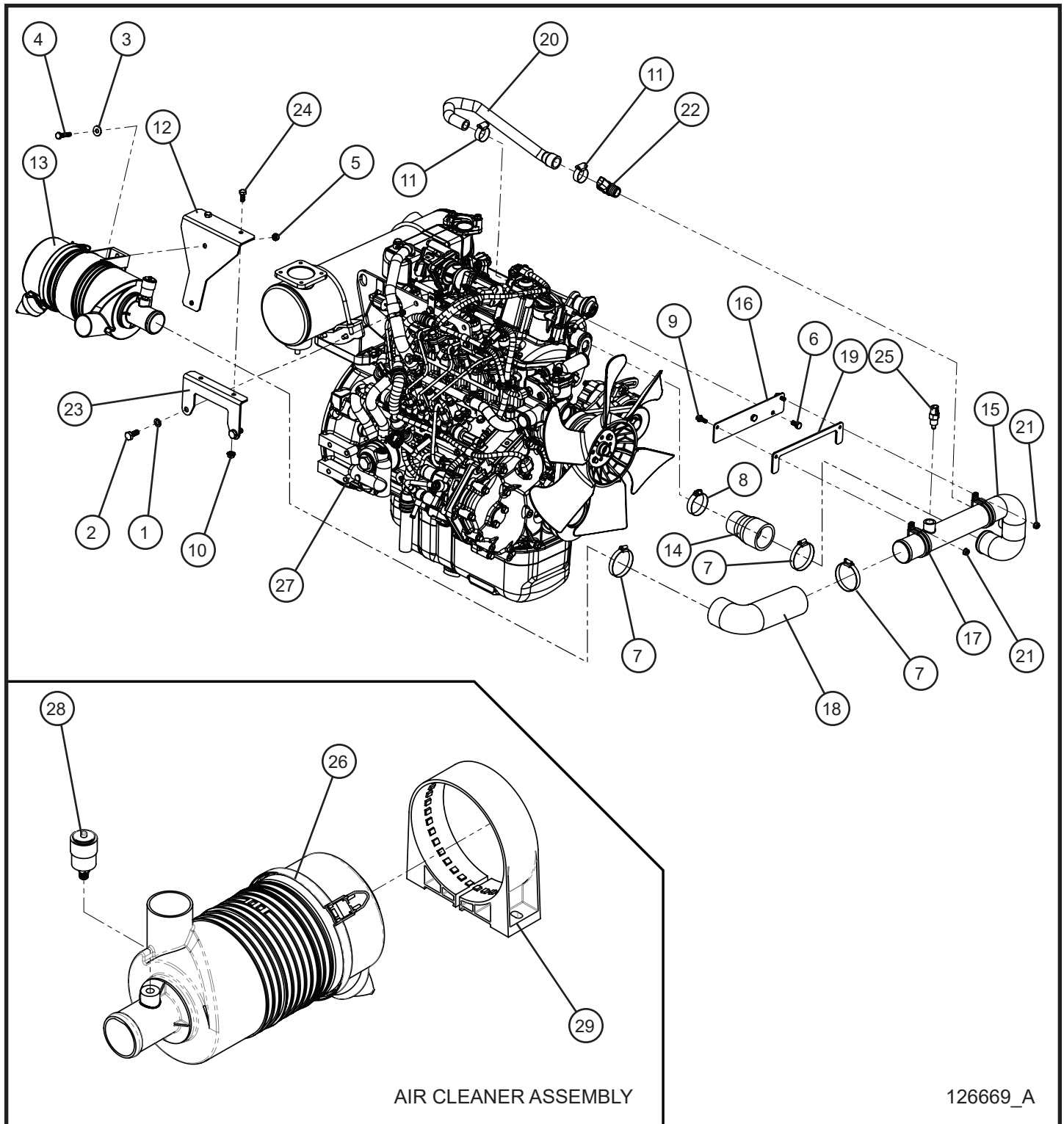

13.3 - Isuzu 4LE2T Engine DSE L401 Assembly Group II (2 of 4)

Item	Part No.	Part Description	Qty.
1	042151	M10 SPLITLOCK WASHER	10
2	102130	M10 x 25mm x 1.25mm HEX HEAD BOLT	2
3	047010	5/16 FLAT WASHER	2
4	102127	M8 x 35mm x 1.25mm HEX HEAD BOLT	2
5	042081	M8 x 1.25mm NYLOCK HEX NUT	2
6	042027	M8 x 16mm x 1.25mm HEX HEAD BOLT	2
7	045038	#32 HOSE CLAMP	3
8	045036	#24 HOSE CLAMP	1
9	056002	1/4-20 x 3/4 HEX SERRATED FLANGE SCREW	8
10	057006	5/16-18 SERRATED FLANGE NUT	2
11	045032	#12 HOSE CLAMP	2
12	121234P	AIR CLEANER BRACKET ISUZU 4LE2T MP25	1
13	106072	AIR CLEANER ASSEMBLY	1
14	106987	2.00 to 1.50 ISUZU 4LE2T AIR INTAKE ADAPTER	1
15	123258	AIR INTAKE TUBE PRESS FIT HEATER ISUZU 4LE2T	1
16	107009P	ISUZU 4LE2T INTAKE SUPPORT BRACKET	1
17	022008	#32 CUSHION CLAMP 1/4 HOLE	2
18	106673	ISUZU 4LE2T 90° INTAKE HOSE ELBOW	1
19	107011P	ISUZU 4LE2T INTAKE SUPPORT SPACER	1
20	125025	PCV HOSE ISUZU 4LE2T STRAIGHT HEATER	1
21	057001	1/4-20 HEX NYLOCK FLANGE NUT	4
22	106943	HEATER PCV	1
23	121096P	AIR CLEANER BRACKET ISUZU 4LE2T MP25	1
24	046045	5/16-18 X 3/4 HEX HEAD CS	2
25	N/A	AIR TEMPERATURE SENDER	1
26	104061	DONALDSON AIR CLEANER ASSEMBLY	1
	15-000125	PRIMARY FILTER	1
	104071	SAFETY FILTER	1
27	921140	AIR CLEANER BAND MOUNT	1
29	104795	AIR FILTER SERVICE INDICATOR KIT	1

13.3 - Isuzu 4LE2T Engine DSE L401 Assembly Group II (3 of 4)

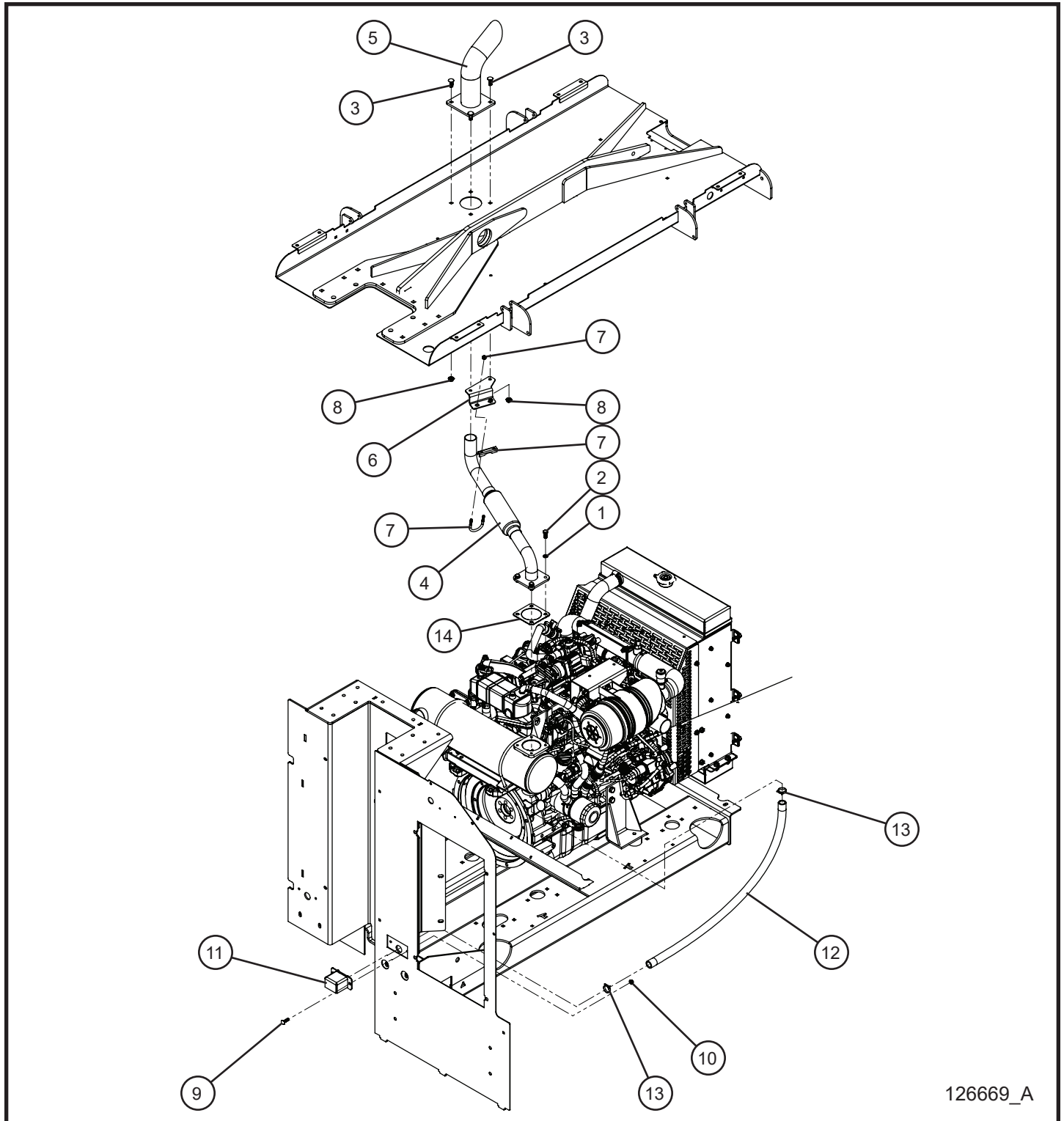

126669_A

13.3 - Isuzu 4LE2T Engine DSE L401 Assembly Group II (3 of 4)

Item	Part No.	Part Description	Qty.
1	043055	5/16 SPLITLOCK WASHER	10
2	042033	M8 x 20mm x 1.25mm HEX HEAD BOLT	4
3	053020	5/16-18 x 1 CARRIAGE BOLT	4
4	107125	ISUZU 4LE2T EXHAUST	1
5	107124	EXHAUST STACK	1
6	113477P	ISUZU 4LE2T EXHAUST CLAMP MOUNT	1
7	713086	1-3/8 MUFFLER CLAMP	1
8	057006	5/16-18 SERRATED FLANGE NUT	4
9	100342	1/4-20 x 1 CARRIAGE BOLT	2
10	057001	1/4-20 HEX NYLOCK FLANGE NUT	4
11	108894P	ISUZU 4LE2T SECONDARY EXHAUST GUARD	1
12	082000	7/16 PTFE TUBING x 31.0	1
13	045100	7.5 STSF SILVER CONSTANT TENSION CLAMP	2
14	N/A	EXHAUST FLANGE GASKET	1

13.3 - Isuzu 4LE2T Engine DSE L401 Assembly Group II (4 of 4)

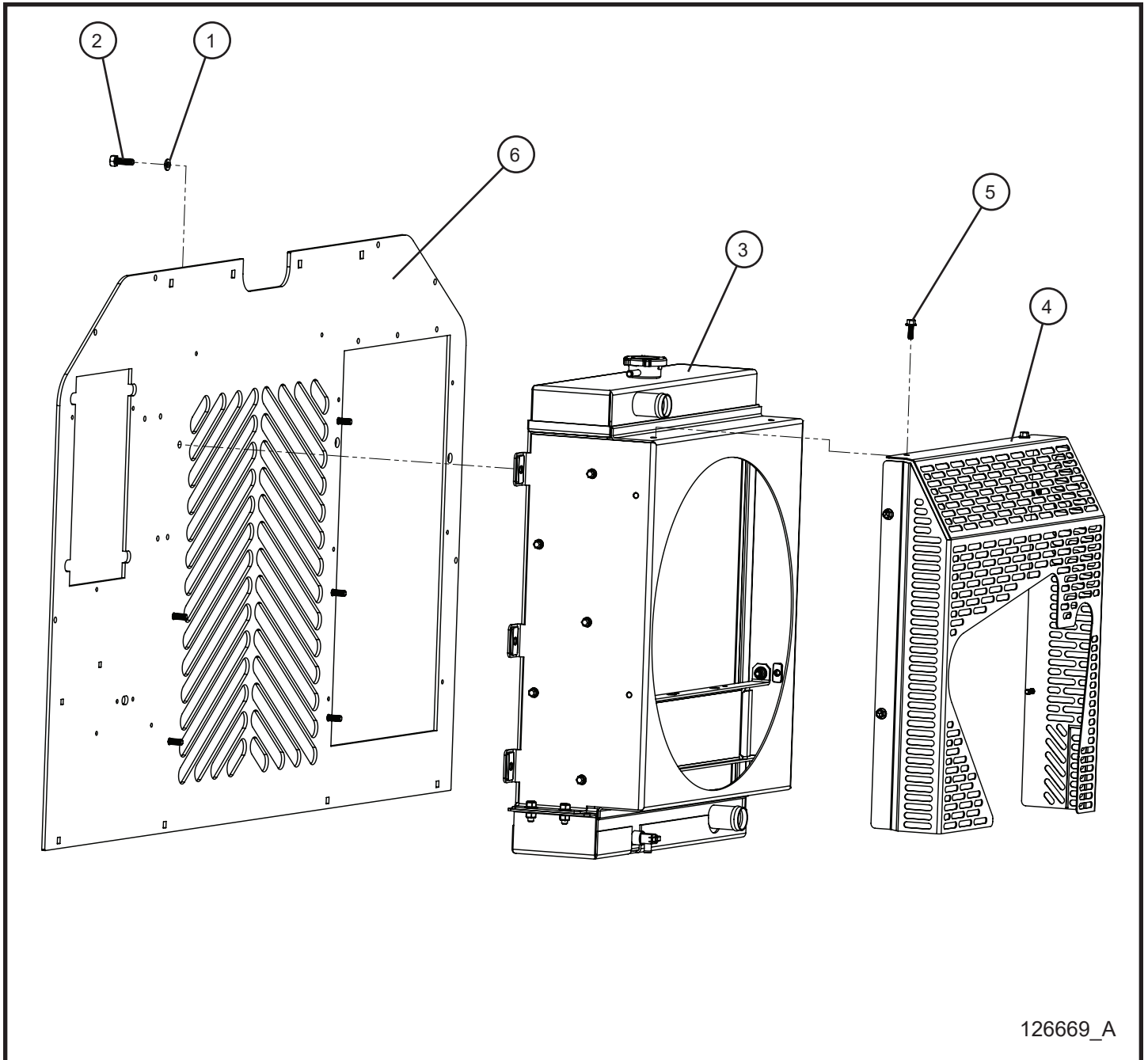

126669_A

13.3 - Isuzu 4LE2T Engine DSE L401 Assembly Group II (4 of 4)

Item	Part No.	Part Description	Qty.
1	043055	5/16 SPLITLOCK WASHER	6
2	046050	5/16-18 x 1 HEX HEAD BOLT	6
3	125586	RADIATOR ISUZU 4LE2T SHORT SHROUD	1
4	126667P	FINGER GUARD ISUZU 4LE2T SHORT SHROUD MAXI-LITE	1
5	056002	1/4-20 x 3/4 HEX SERRATED FLANGE SCREW	6
6	107010P	ISUZU 4LE2T REAR PANEL	1

13.3 - Isuzu 4LE2T Engine DSE L401 Assembly Group II (4 of 4)

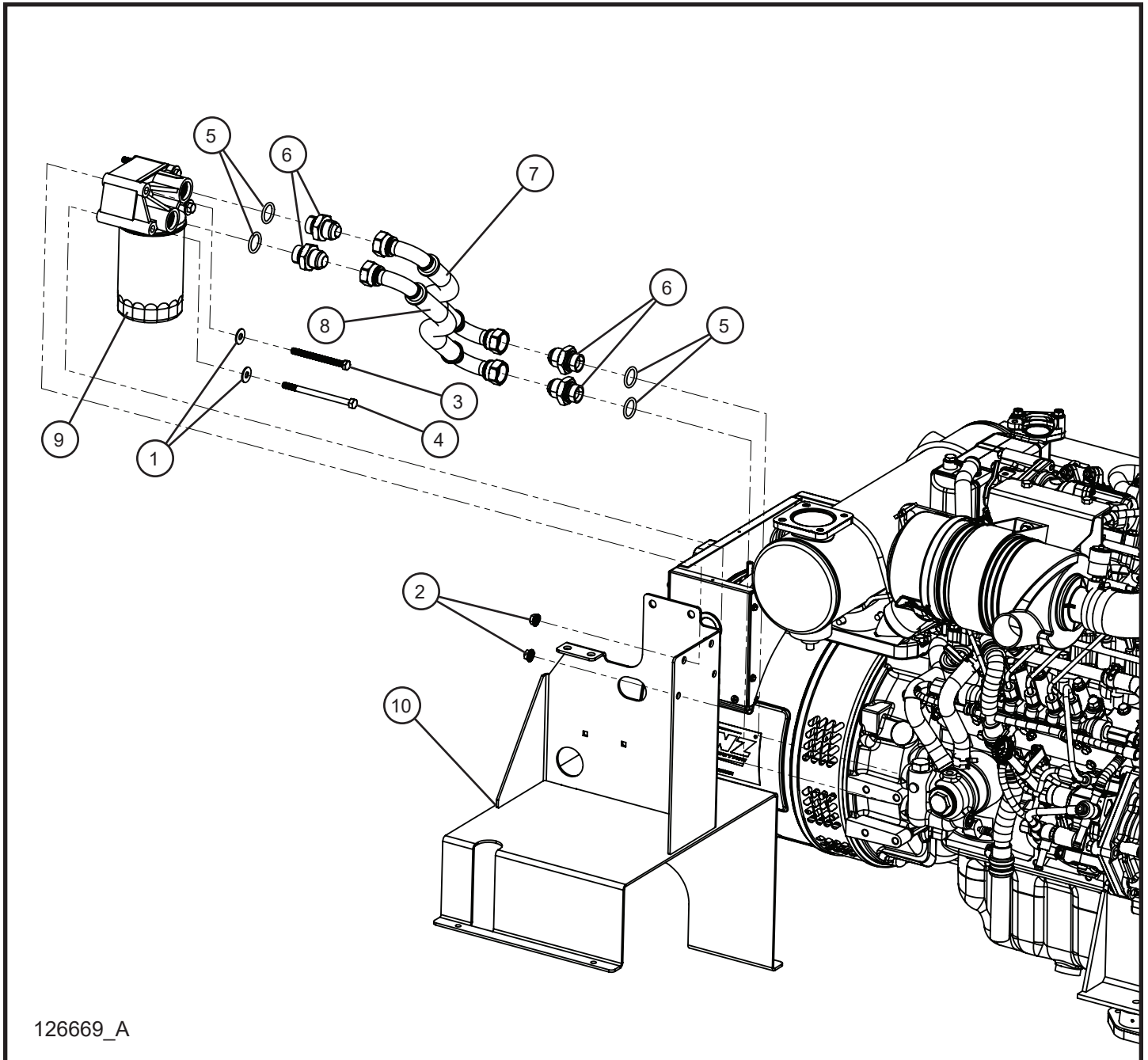

13.3 - Isuzu 4LE2T Engine DSE L401 Assembly Group II (4 of 4)

Item	Part No.	Part Description	Qty.
1	047010	5/16 FLAT WASHER	4
2	057006	5/16-18 SERRATED FLANGE NUT	4
3	046077	5/16-18 x 3 1/2 FT HEX HEAD BOLT	2
4	046080	5/16-18 x 4 1/2 HEX HEAD BOLT	2
5	123288	O-RING ISUZU REMOTE OIL	4
6	124424	12F40MXS TRIPLE LOK BSPP ORR	4
7	126692	ASSY HOSE REMOTE OIL FILTER PUSH LOK 12" MAXI-LITE	1
8	126693	ASSY HOSE REMOTE OIL FILTER PUSH LOK 13" MAXI-LITE	1
9	126689P	WELDMENT MOUNT FUEL/OIL FILTER ISUZU 4LE2T MAXI-LITE	1
10	650221	ISUZU OIL FILTER	1

13.3 - Isuzu 4LE2T Engine Fuel Lines with Fuel Cooler

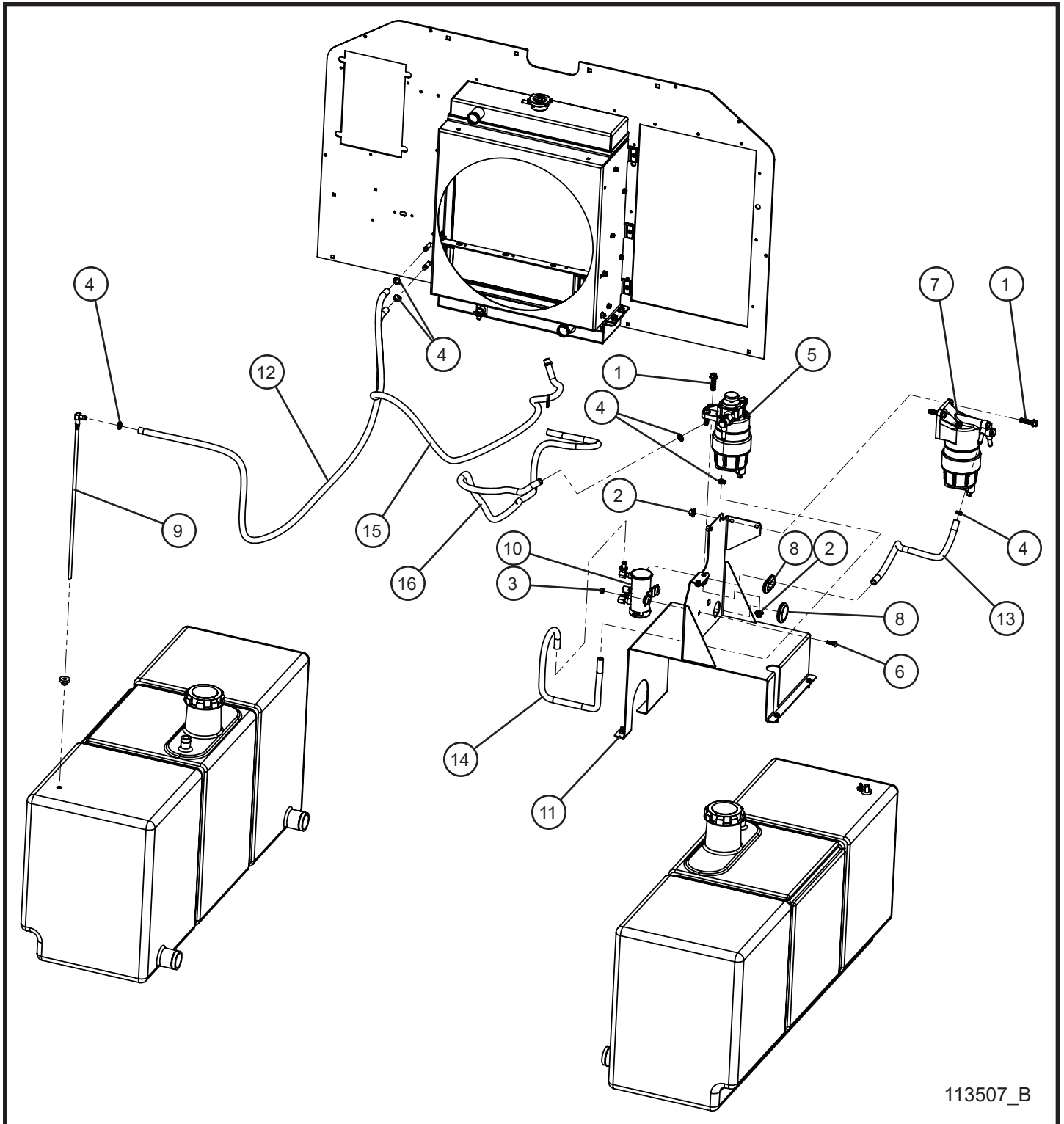

113507_B

13.3 - Isuzu 4LE2T Engine Fuel Lines with Fuel Cooler

Item	Part No.	Part Description	Qty.
1	056015	3/8-16 x 1 1/2 HEX FLANGE SCREW	4
2	044029	3/8-16 SERRATED FLANGE NUT	4
3	057001	1/4-20 HEX NYLOCK FLANGE NUT	4
4	433400	#4 HOSE CLAMP	12
5	111647	PRIMARY FUEL FILTER ELEMENT	1
6	100342	1/4-20 x 1 CARRIAGE BOLT	4
7	111648	SECONDARY FUEL FILTER ELEMENT	1
8	106542	RUBBER GROMMET	3
9	113326	3/8 HOSE BARB DROP TUBE MAXI-LITE	2
10	113008	ELECTRIC FUEL PUMP	1
	112896	ELECTRIC FUEL PUMP SERVICE FILTER ELEMENT	1
11	107007P	ISUZU 4LE2T FUEL FILTER & PUMP BRACKET	1
12	101266	HOSE 3/8 SAE 30R7 x 70.00	1
13	101266	HOSE 3/8 SAE 30R7 x 20.00	1
14	101266	HOSE 3/8 SAE 30R7 x 26.00	1
15	101266	HOSE 3/8 SAE 30R7 x 56.00	1
16	101266	HOSE 3/8 SAE 30R7 x 43.00	1
NS	041070	1/4-20 x 3/4 SL-HEX WASHER HEAD MACHINE SCREW	2
NS	101701	1/4 PUSH NUT	2
NS	101266	HOSE 3/8 SAE 30R7 x 60.00	1

13.4 - Isuzu 4LE2T Engine Fuel Lines I

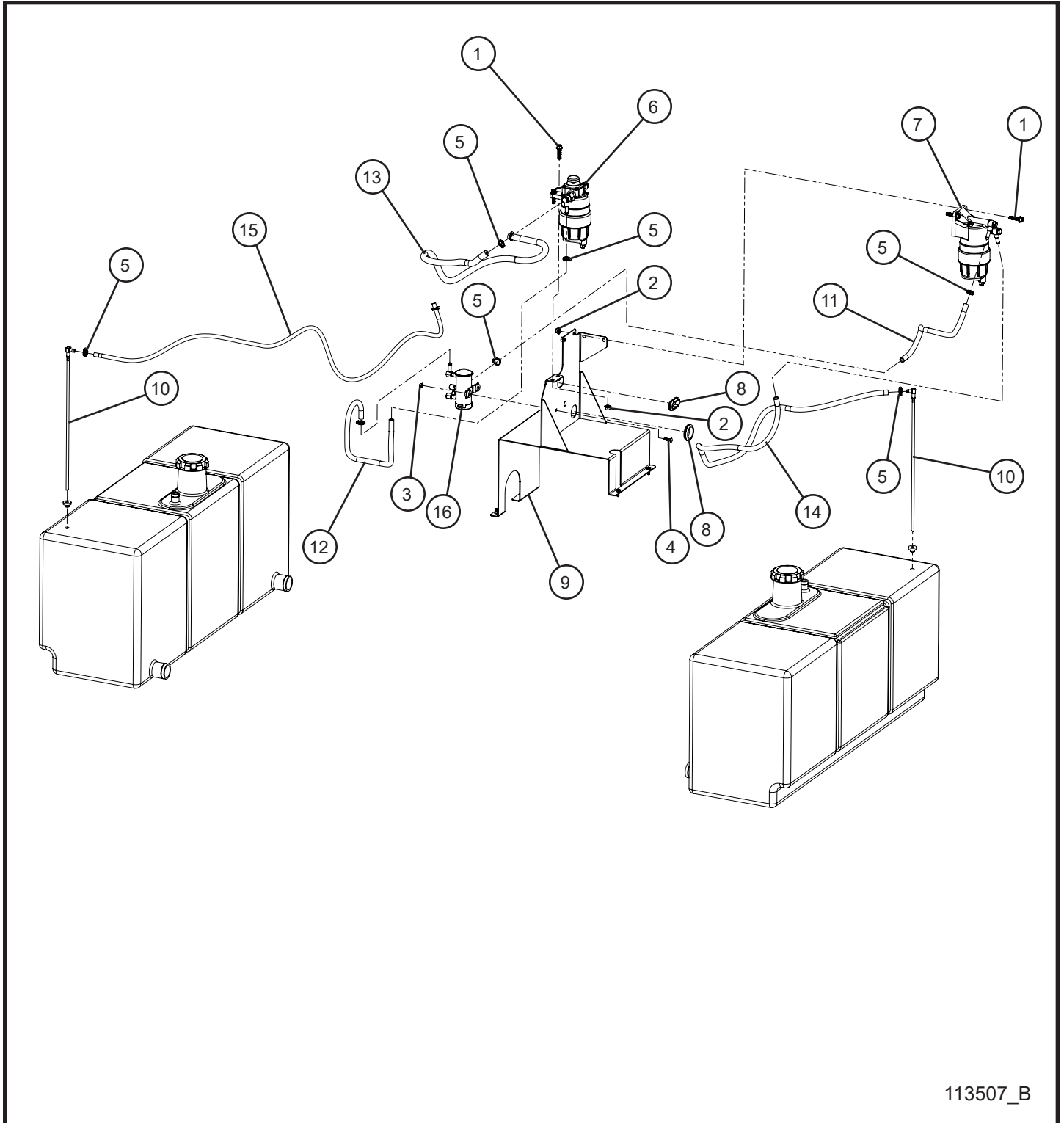

113507_B

13.4 - Isuzu 4LE2T Engine Fuel Lines I

Item	Part No.	Part Description	Qty.
1	056015	3/8-16 x 1 1/2 HEX FLANGE SCREW	4
2	044029	3/8-16 SERRATED FLANGE NUT	4
3	057001	1/4-20 HEX NYLOCK FLANGE NUT	4
4	100342	1/4-20 x 1 CARRIAGE BOLT	4
5	433400	#4 HOSE CLAMP	10
6	111647	PRIMARY FUEL FILTER ELEMENT	1
7	111648	SECONDARY FUEL FILTER ELEMENT	1
8	106542	RUBBER GROMMET	3
9	107007P	ISUZU 4LE2T FUEL FILTER & PUMP BRACKET	1
10	113326	3/8 HOSE BARB DROP TUBE MAXI-LITE	2
11	101266	HOSE 3/8 SAE 30R7 x 20.00	1
12	101266	HOSE 3/8 SAE 30R7 x 26.00	1
13	101266	HOSE 3/8 SAE 30R7 x 43.00	1
14	101266	HOSE 3/8 SAE 30R7 x 60.00	1
15	101266	HOSE 3/8 SAE 30R7 x 88.00	1
16	113008	ELECTRIC FUEL PUMP	1
	112896	ELECTRIC FUEL PUMP SERVICE FILTER ELEMENT	1
NS	041070	1/4-20 x 3/4 SL-HEX WASHER HEAD MACHINE SCREW	2
NS	101701	1/4 PUSH NUT	2
NS	022018	#8 CUSH CLAMP	1
NS	053020	5/16-18 X 1 CARRIAGE BOLT	1
NS	057006	5/16-18 SERRATED FLANGE NUT	1

13.5 - Isuzu 4LE2T Engine Fuel Lines II

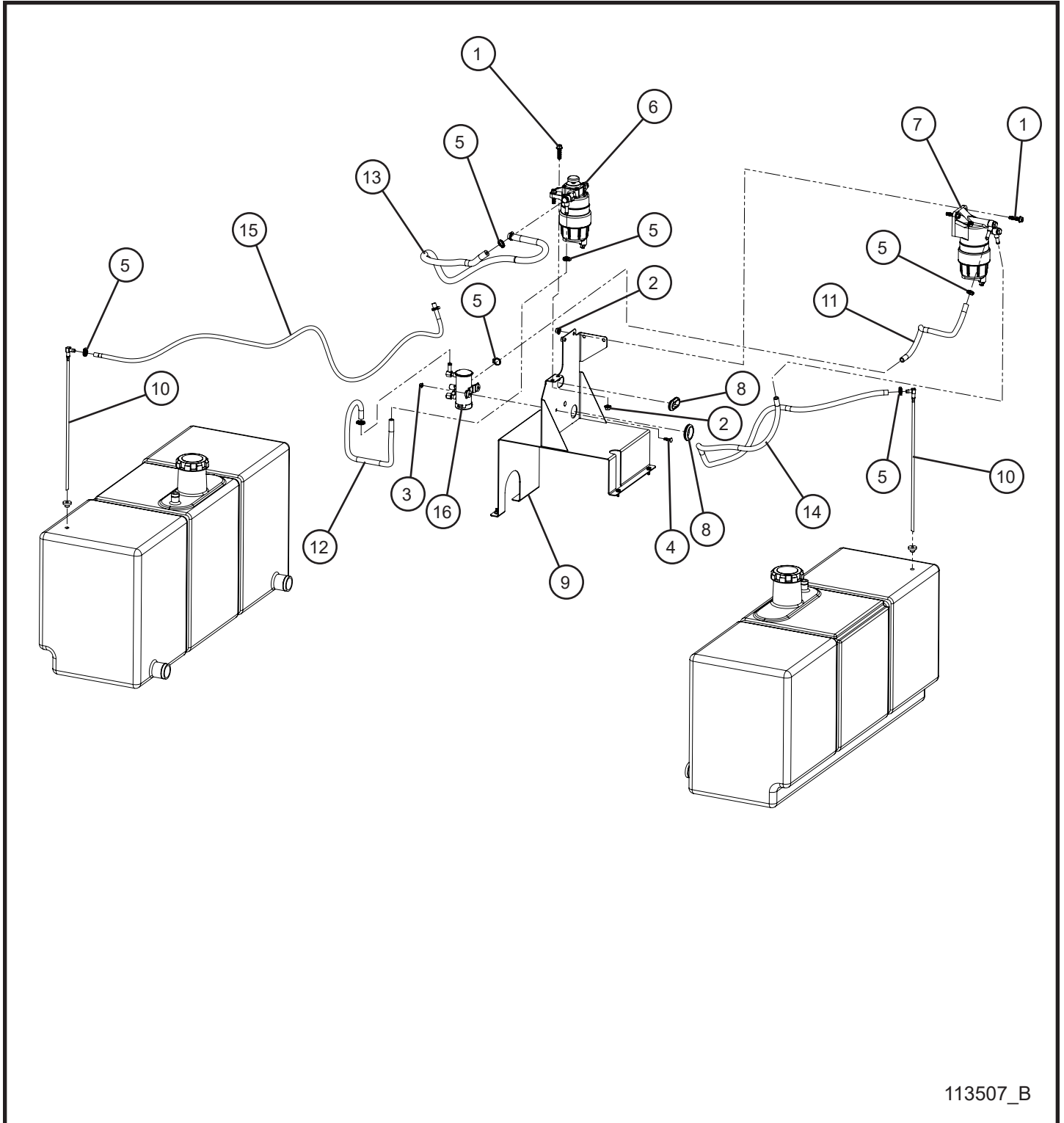

113507_B

13.5 - Isuzu 4LE2T Engine Fuel Lines II

Item	Part No.	Part Description	Qty.
1	056015	3/8-16 x 1 1/2 HEX FLANGE SCREW	4
2	044029	3/8-16 SERRATED FLANGE NUT	4
3	057001	1/4-20 HEX NYLOCK FLANGE NUT	4
4	100342	1/4-20 x 1 CARRIAGE BOLT	4
5	433400	#4 HOSE CLAMP	10
6	111647	PRIMARY FUEL FILTER ELEMENT	1
7	111648	SECONDARY FUEL FILTER ELEMENT	1
8	106542	RUBBER GROMMET	3
9	126689P	WELDMENT MOUNT FUEL/OIL FILTER ISUZU 4LE2T MAXI-LITE	1
10	113326	3/8 HOSE BARB DROP TUBE MAXI-LITE	2
11	101266	HOSE 3/8 SAE 30R7 x 20.00	1
12	101266	HOSE 3/8 SAE 30R7 x 26.00	1
13	101266	HOSE 3/8 SAE 30R7 x 43.00	1
14	101266	HOSE 3/8 SAE 30R7 x 60.00	1
15	101266	HOSE 3/8 SAE 30R7 x 88.00	1
16	113008	ELECTRIC FUEL PUMP	1
	112896	ELECTRIC FUEL PUMP SERVICE FILTER ELEMENT	1
NS	041070	1/4-20 x 3/4 SL-HEX WASHER HEAD MACHINE SCREW	2
NS	101701	1/4 PUSH NUT	2
NS	022018	#8 CUSH CLAMP	1
NS	053020	5/16-18 X 1 CARRIAGE BOLT	1
NS	057006	5/16-18 SERRATED FLANGE NUT	1

13.6 - Isuzu 4LE2T Webasto Thermo Top C Heater Lines

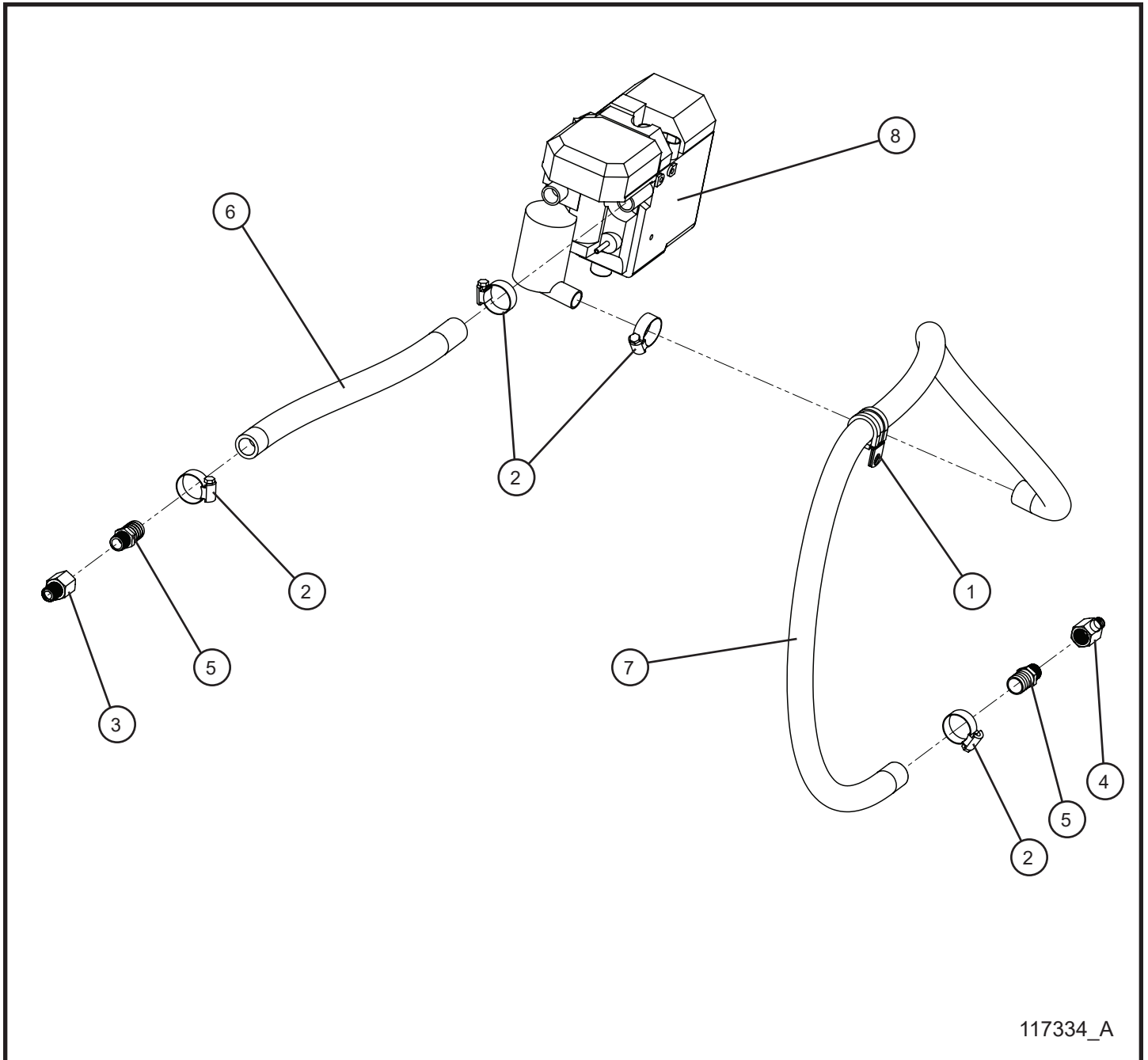

13.6 - Isuzu 4LE2T Webasto Thermo Top C Heater Lines

Item	Part No.	Part Description	Qty.
1	022083	#16 CLAMP CUSH 3/8 HOLE	1
2	045032	#12 HOSE CLAMP	4
3	104798	FITTING ADAPTOR 3/8" BSPT TO 3/8" NPT	1
4	112581	FITTING ADAPTOR 1/4" BSPT TO 3/8" NPT	1
5	104683	3/8" NPT - 3/4" BARB FITTING HOSE BARB	2
6	105016	3/4" HEATER HOSE x 17.0	1
7	105016	3/4" HEATER HOSE x 55.0	1
8	104946	WEBASTO TT C DIESEL FIRED COOLANT HEATER KIT	1

13.7 - Isuzu 4LE2T Webasto Thermo Top EVO Heater Lines

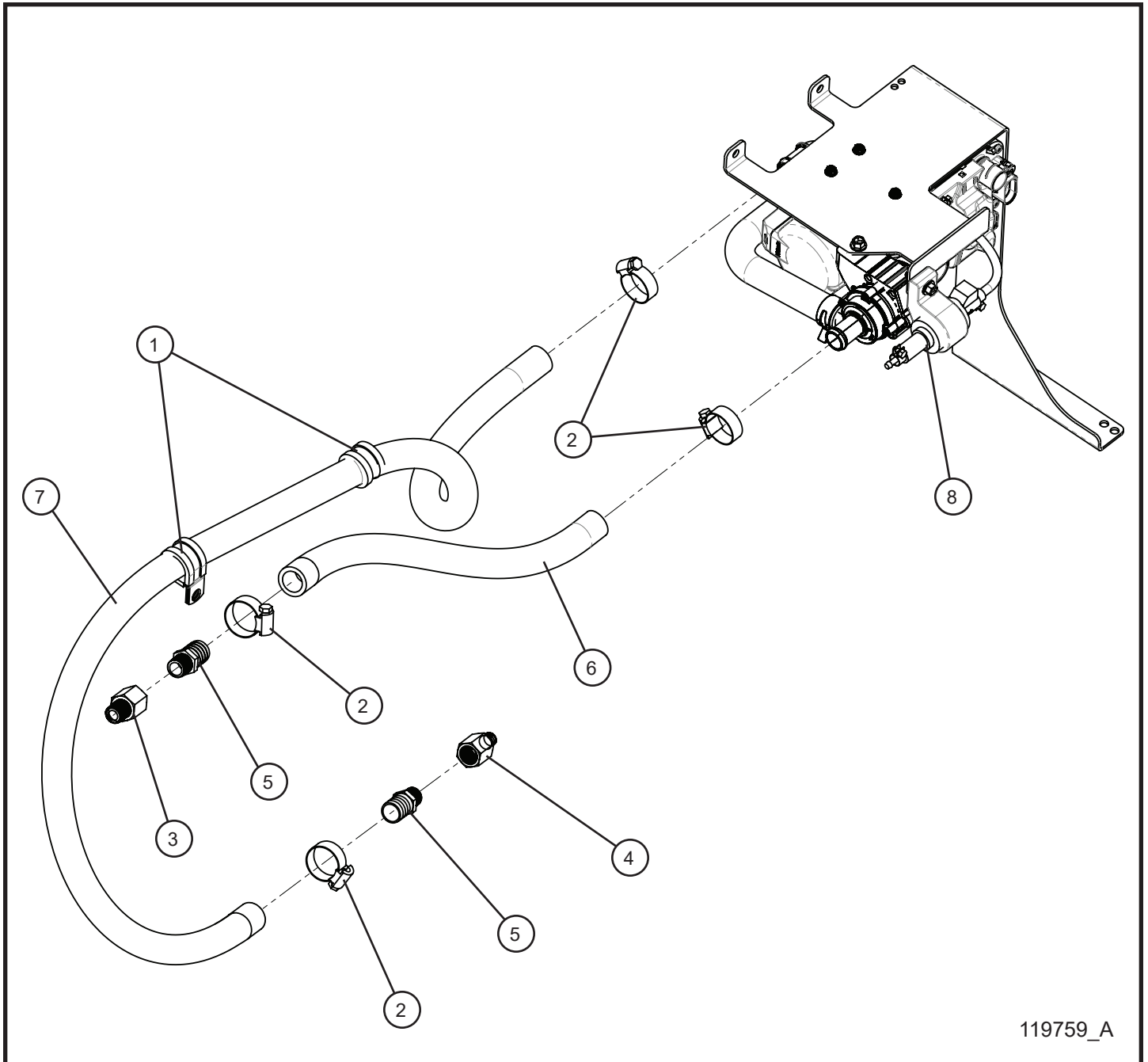

13.7 - Isuzu 4LE2T Webasto Thermo Top EVO Heater Lines

Item	Part No.	Part Description	Qty.
1	022083	#16 CLAMP CUSH 3/8 HOLE	1
2	045032	#12 HOSE CLAMP	4
3	104798	FITTING ADAPTOR 3/8" BSPT TO 3/8" NPT	1
4	112581	FITTING ADAPTOR 1/4" BSPT TO 3/8" NPT	1
5	104683	3/8" NPT - 3/4" BARB FITTING HOSE BARB	2
6	105016	3/4" HEATER HOSE x 13.0	1
7	105016	3/4" HEATER HOSE x 60.0	1
8	118278	WEBASTO TT EVO DIESEL FIRED COOLANT HEATER KIT	1

13.7 - Isuzu 4LE2T Engine Shocker Group (1 of 2)

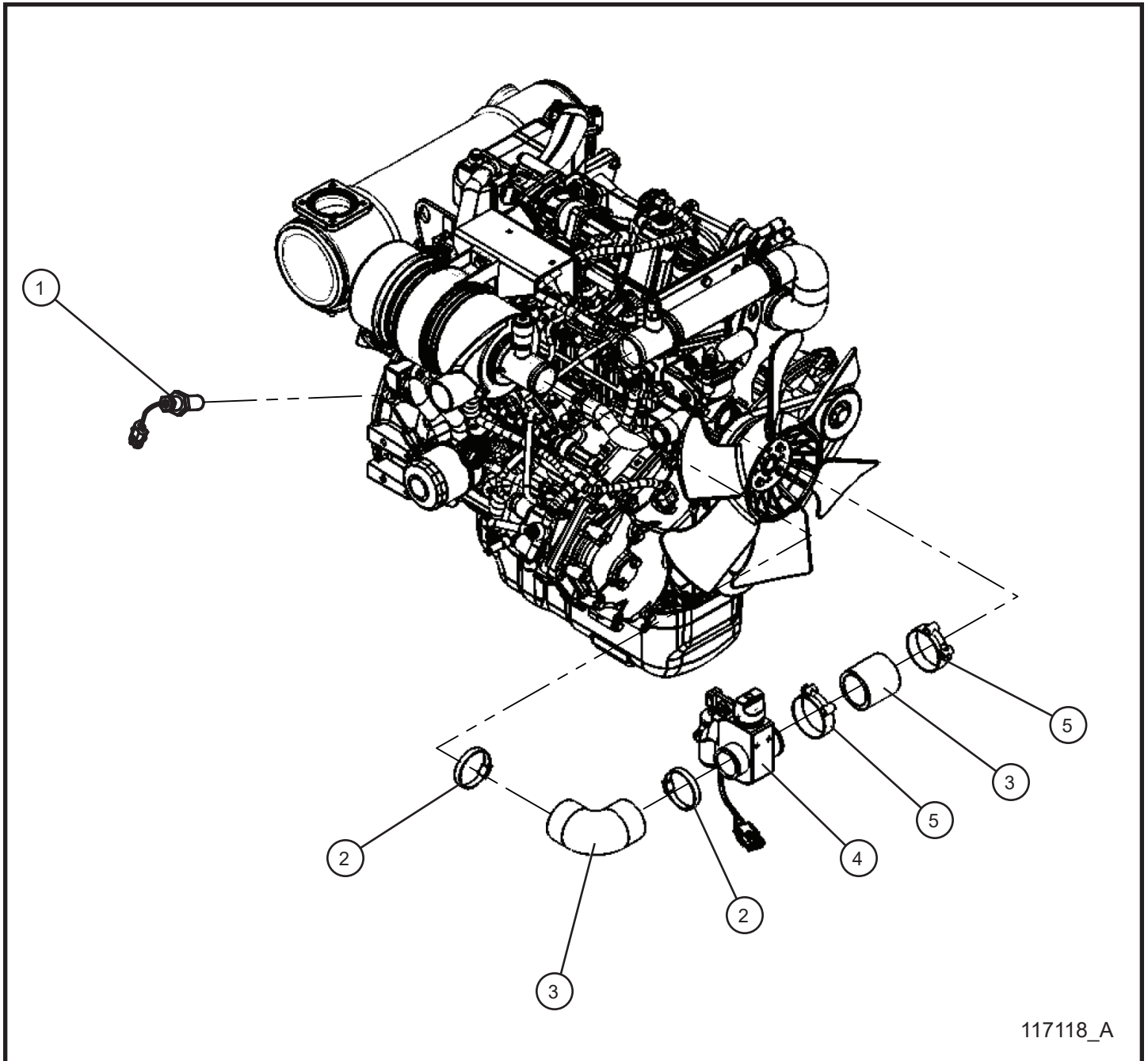

117118_A

13.7 - Isuzu 4LE2T Engine Shocker Group (1 of 2)

Item	Part No.	Part Description	Qty.
1	105537	MAGNETIC SENSOR 3/4 x 16 WITH PLUG	1
2	045038	#32 HOSE CLAMP	2
3	106673	ISUZU 4LE2T 90° INTAKE HOSE ELBOW	1
4	105810	SHOCKER 2" VALVE DELPHI 3 PIN CONNECTOR	1
5	105649	2 INCH STAINLESS STEEL T-BOLT CLAMP	2
NS	105705	SHOCKER 2" VALVE KIT	1
NS	106156	SCHEMATIC SHOCKER VALVE HARNESS	1
NS	105802	HARNESS SHOCKER VALVE	1
NS	105702	SHOCKER SETUP INSTRUCTIONS	1

13.7 - Isuzu 4LE2T Engine Shocker Group (2 of 2)

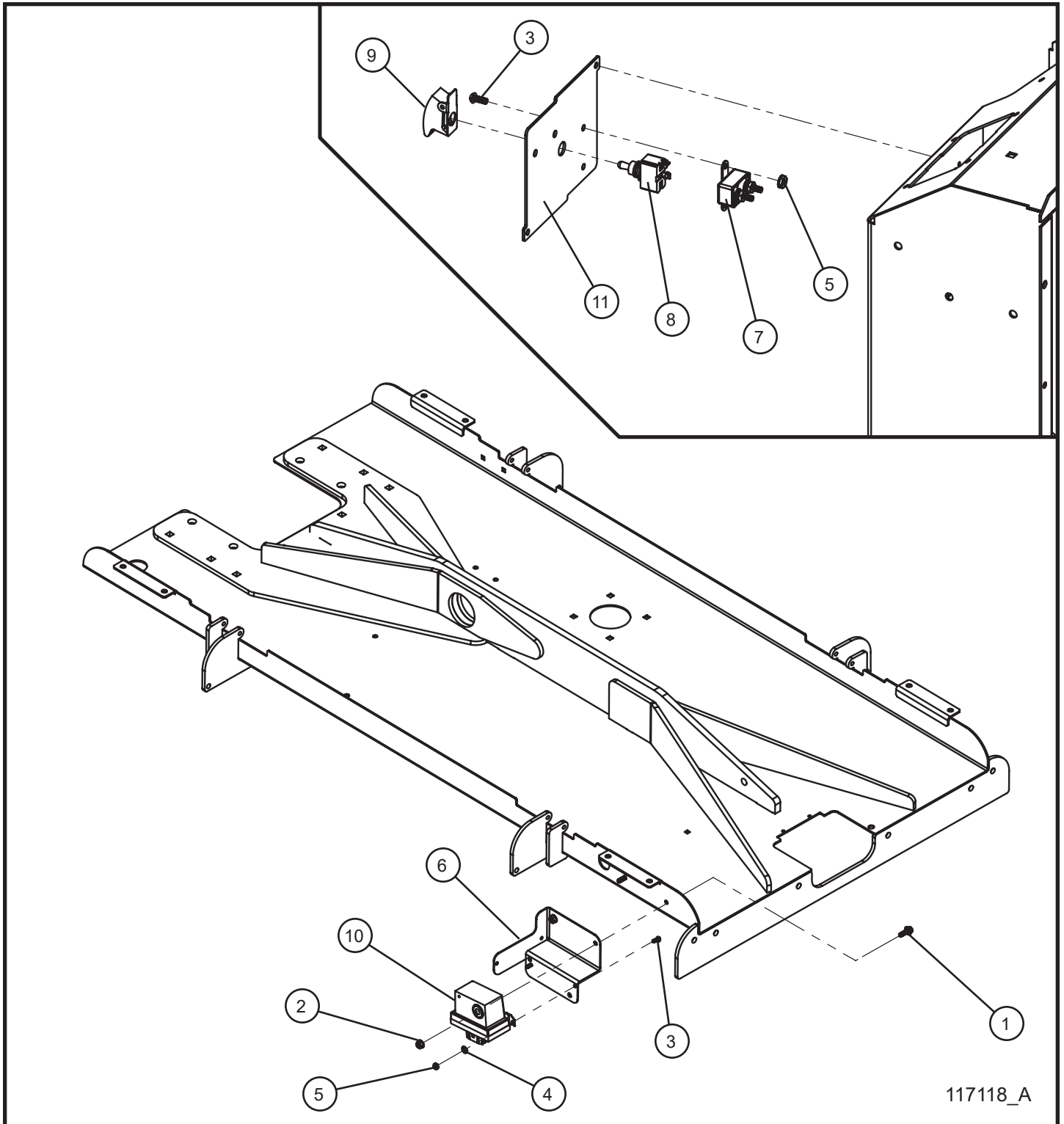

117118_A

13.7 - Isuzu 4LE2T Engine Shocker Group (2 of 2)

Item	Part No.	Part Description	Qty.
1	056002	1/4-20 x 3/4 HEX SERRATED FLANGE SCREW	2
2	057001	1/4-20 HEX NYLOCK FLANGE NUT	2
3	041021	#10-24 x 1/2 PH-ROUND HEAD MACHINE SCREW	4
4	047070	#10 FLAT WASHER	2
5	044018	#10-24 NYLOCK HEX NUT	4
6	113476P	MAXI-LITE SHOCKER CONTROLLER BRACKET	1
7	105636	20 AMP BREAKER	1
8	340009	15A 125V ON/OFF TOGGLE SWITCH	1
9	105645	CONTROLLER PASS TOGGLE SWITCH GUARD	1
10	105692	R5 SHOCKER CONTROLLER	1
11	111228P	MAXI-LITE COMPONENT BOX BACK COVER	1
NS	105705	SHOCKER 2" VALVE KIT	1
NS	106156	SCHEMATIC SHOCKER VALVE HARNESS	1
NS	105802	HARNESS SHOCKER VALVE	1
NS	105702	SHOCKER SETUP INSTRUCTIONS	1

13.8 - Isuzu 4LE2T Engine PacBrake Group

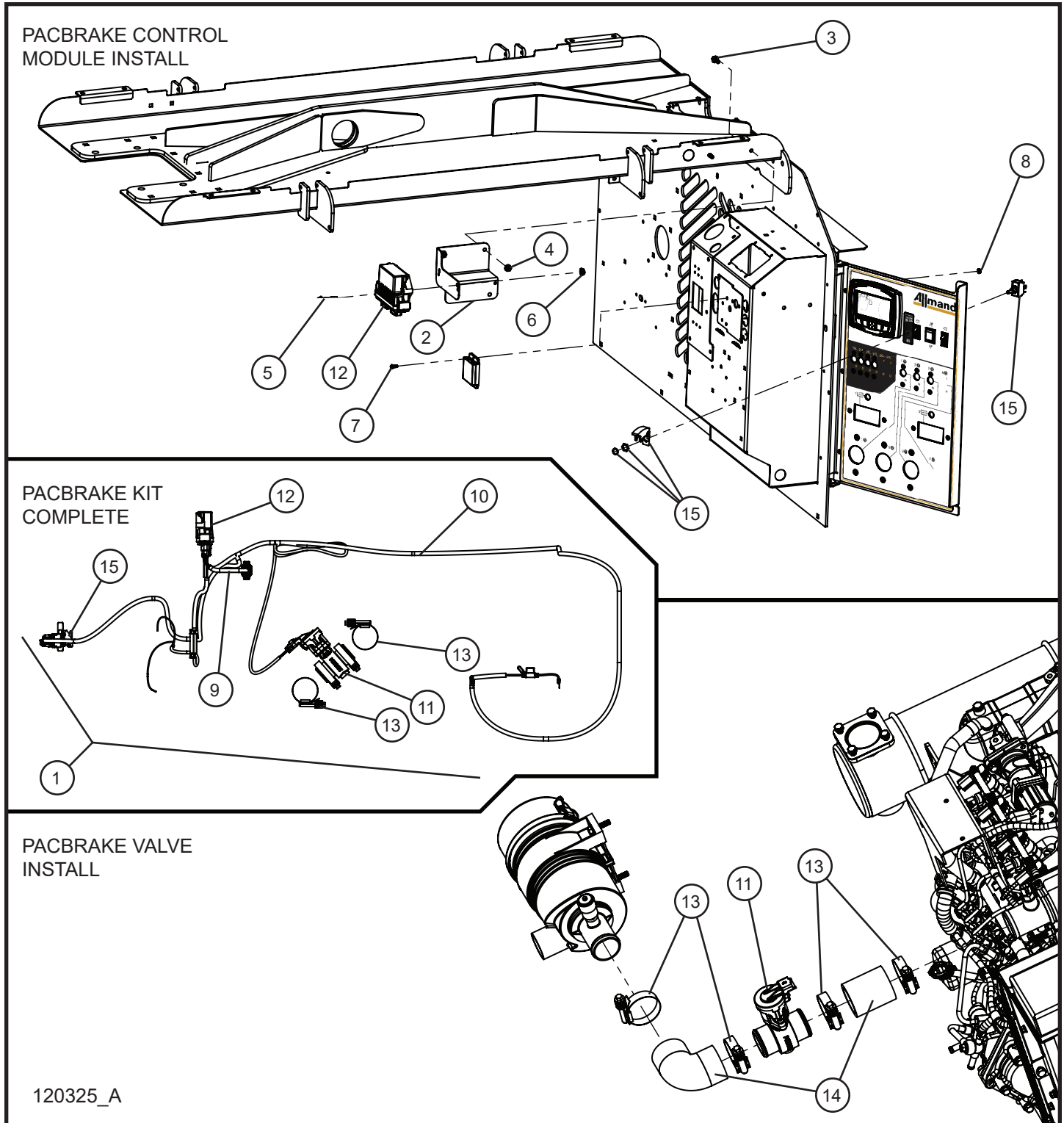

13.8 - Isuzu 4LE2T Engine PacBrake Group

Item	Part No.	Part Description	Qty.
1	122098	PACBRAKE 1.75" AIR INTAKE VALVE KIT COMPLETE MAXI-LITE	1
2	113476P	MAXI-LITE SHOCKER CONTROLLER BRACKET	1
3	056002	1/4-20 X 3/4 HEX SERRATED FLANGE SCREW	2
4	057001	1/4-20 HEX NYLOCK FLANGE NUT	2
5	056012	1/4-20 x 1 1/2 SERRATED FLANGE HEX HEAD SCREW	2
6	057000	1/4-20 HEX SERRATED FLANGE NUT	2
7	041012	#8-32 X 1/2 PL SCREW MS	2
8	044003	#8-32 NC KEPS NUT	2
9	122731	PACBRAKE AC FREQUENCY WIRE HARNESS MAXI-LITE	1
10	122732	PACBRAKE DC WIRE HARNESS MAXI-LITE	1
11	122747	PACBRAKE 2.00" AIR INTAKE VALVE	1
12	122736	PACBRAKE AIR INTAKE VALVE CONTROL MODULE	1
13	122737	PACBRAKE SAE 262 BAND CLAMP	4
14	106673	ISUZU 4LE2T 90° INTAKE HOSE ELBOW	1
15	122739	PACBRAKE TOGGLE SWITCH KIT	1
NS	103864	FUSE HOLDER INLINE BLADE	1
NS	104990	FUSE BLADE 2 AMP ATO/ATC	1
NS	105844	15 AMP MINI FUSE	1
NS	117814	WIRE SCHEMATIC PACBRAKE AIR VALVE	1

NS - Not Shown

* * * - Contact Allmand for more information.

13.9 - Isuzu 4LE2T Engine Exhaust Blanket

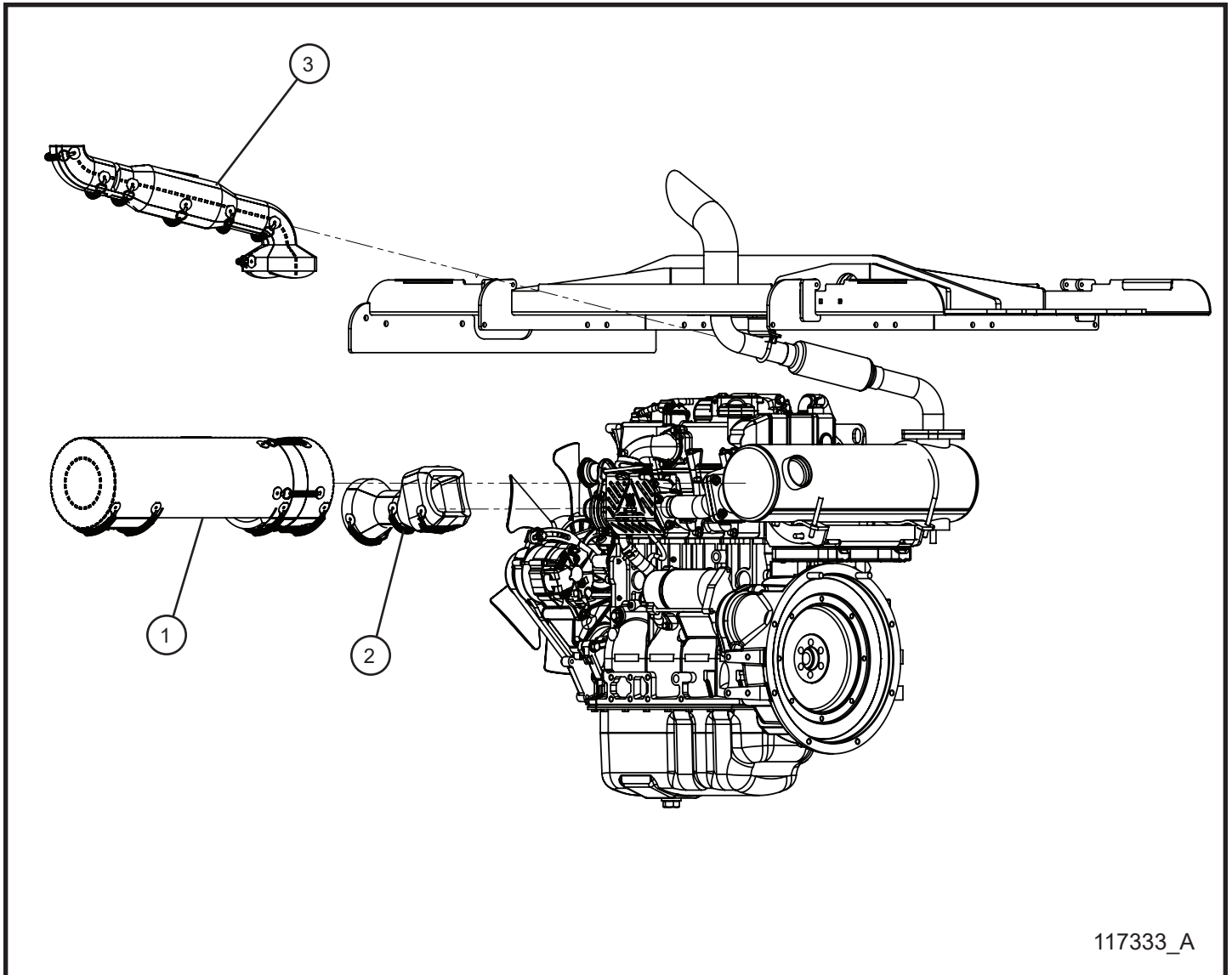

117333_A

13.9 - Isuzu 4LE2T Engine Exhaust Blanket

Item	Part No.	Part Description	Qty.
1	116396	ISUZU 4LE2T DOC EXHAUST BLANKET	1
2	116397	ISUZU 4LE2T TURBOCHARGER EXHAUST BLANKET	1
3	116398	ISUZU 4LE2T EXHAUST PIPE BLANKET	1

14.1 - 8kW Marathon Generator

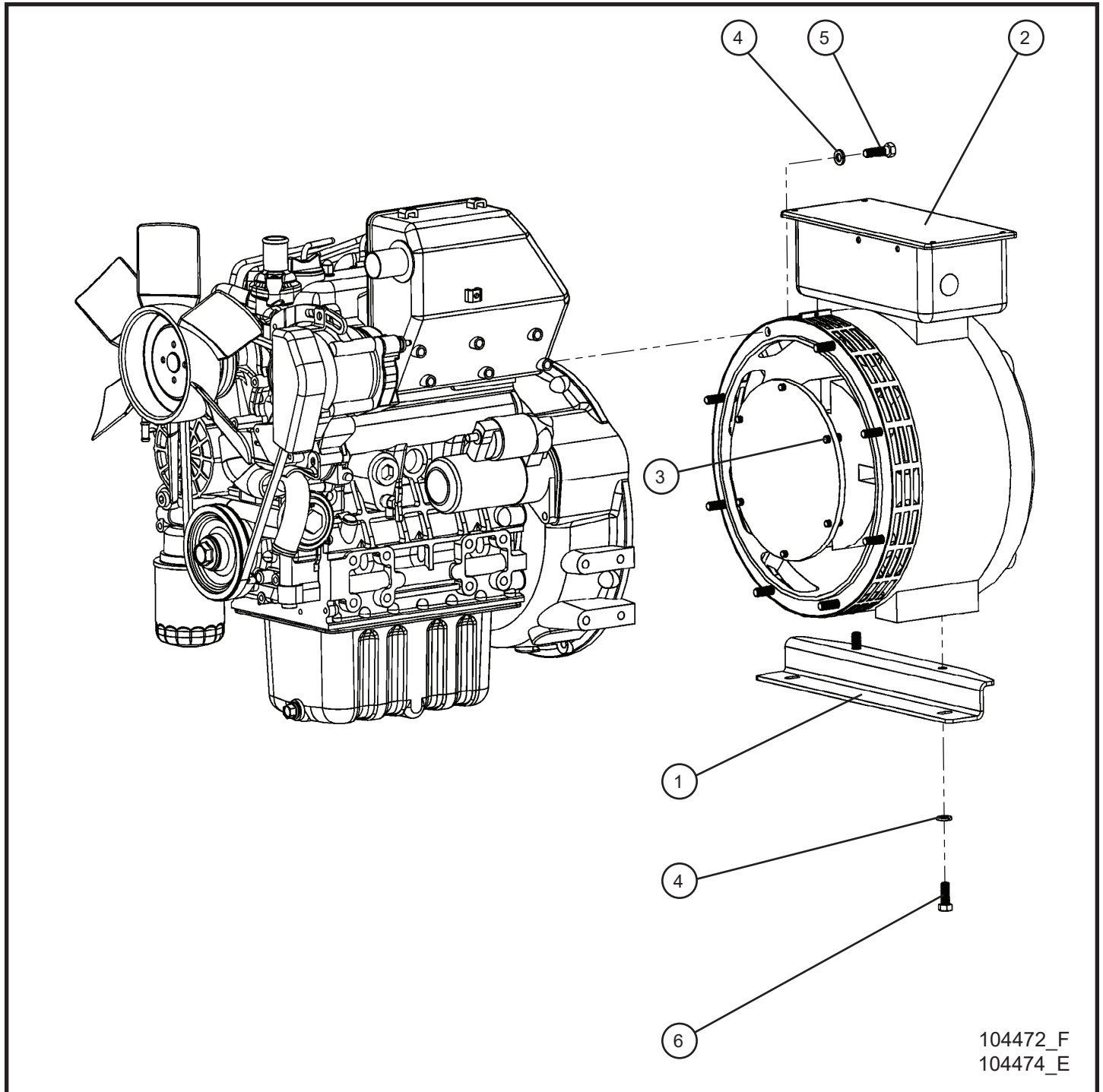

14.1 - 8kW Marathon Generator

Item	Part No.	Part Description	Qty.
1	651012P	GENERATOR MOUNT BRACKET	1
2	101075	GENERATOR MARATHON 8kW 60Hz	1
	654000	GENERATOR MARATHON 8kW 60Hz AVR	1
3	046041	5/16-18 x 1/2 PT FLANGE HEAD BOLT	6
4	043065	3/8 SPLITLOCK WASHER	10
5	046115	3/8-16 x 1 1/4 HEX HEAD BOLT	8
6	046110	3/8-16 x 1 HEX HEAD BOLT	2

14.2 - 8kW Marathon Generator Cord Install Group

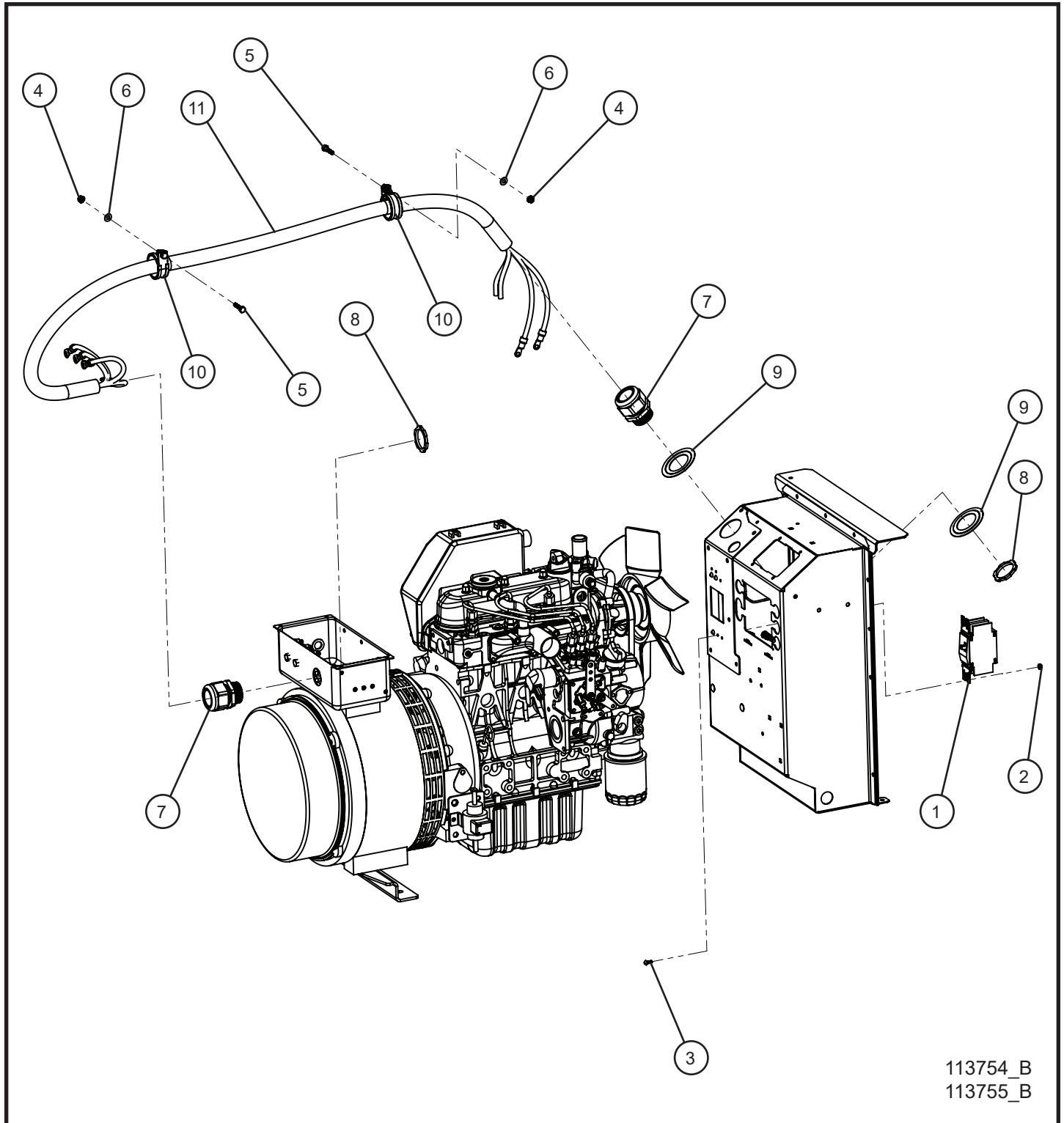

14.2 - 8kW Marathon Generator Cord Install Group

Item	Part No.	Part Description	Qty.
1	350354	35 AMP DOUBLE POLE BREAKER	1
2	057003	#8-32 SERRATED FLANGE HEX LOCKNUT	4
3	056006	#8-32 X 1/2 SERRATED FLANGE HEX SCREW	4
4	044021	1/4-20 KEPS HEX HUT	2
5	046015	1/4-20 x 1 HEX HEAD BOLT	2
6	047009	1/4 FLAT WASHER	2
7	105628	1-1/4 CORD GRIP	2
8	350363	1-1/4 LOCKNUT	2
9	022023	2 x 1-1/4 REDUCING WASHER	2
10	106144	1 1/2 CUSH CLAMP W/ 3/8 HOLE	2
11	113762	8kW 6/4 MAXI-LITE GENERATOR CORD (MARATHON AVR)	1
	125007	8kW 6/4 MAXI-LITE GENERATOR CORD (MARATHON)	1
NS	113929	DECAL MAIN BREAKER ML II	1
NS	124712	6/8kW 50/60Hz 6/4 MAXI-LITE GENERATOR CORD SCHEMATIC	1

14.3 - 15kW 1PH Marathon Generator

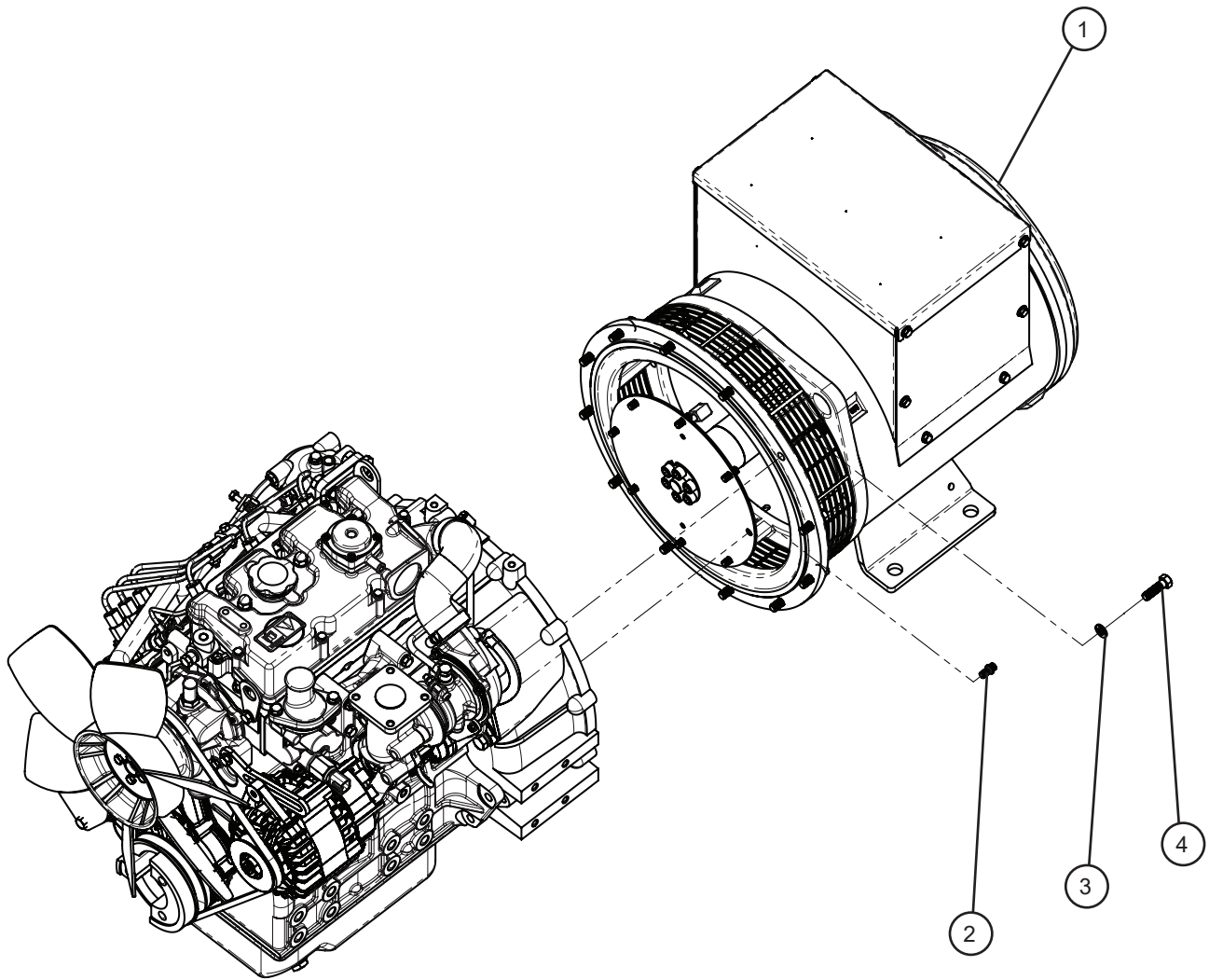

106224_A

14.3 - 15kW 1PH Marathon Generator

Item	Part No.	Part Description	Qty.
1	106214	GEN MARATHON 15kW 60Hz	1
2	046041	5/16-18 x 1/2" 12 PT FLANGE HEAD BOLT	8
3	043065	3/8 SPLITLOCK WASHER PL	12
4	046115	3/8-16 x 1 1/4 HEX HEAD CS GR5 PL	12

14.4 - 15kW 1PH Marathon Generator Cord Install Group

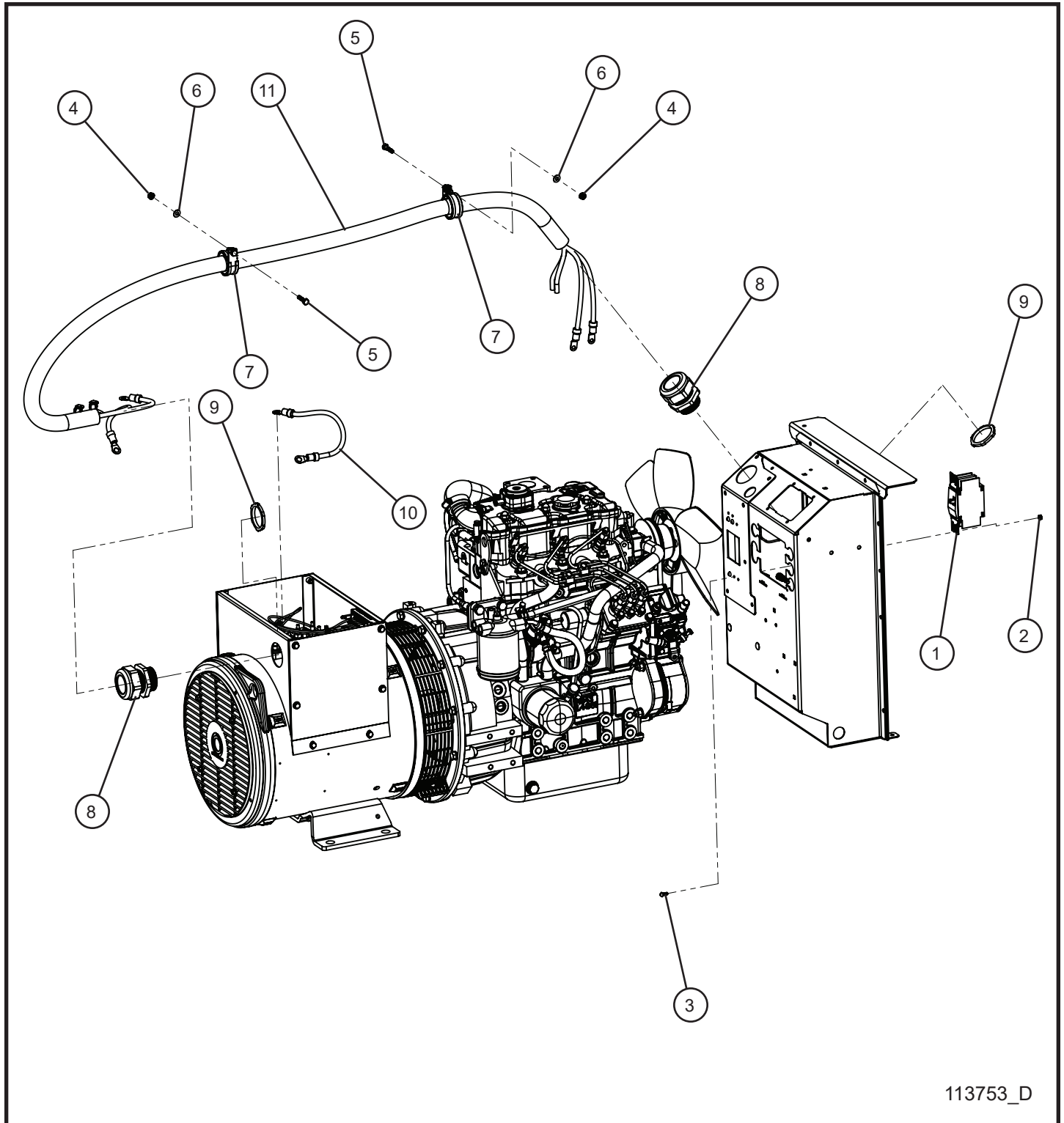

113753_D

14.4 - 15kW 1PH Marathon Generator Cord Install Group

Item	Part No.	Part Description	Qty.
1	353280	70 AMP DOUBLE POLE BREAKER	1
2	057003	#8-32 SERRATED FLANGE HEX LOCKNUT	4
3	056006	#8-32 X 1/2 SERRATED FLANGE HEX SCREW	4
4	044021	1/4-20 KEPS HEX HUT	2
5	046015	1/4-20 x 1 HEX HEAD BOLT	2
6	047009	1/4 FLAT WASHER	2
7	106144	1 1/2 CUSH CLAMP W/ 3/8 HOLE	2
8	105629	1-1/2 CORD GRIP	2
9	022232	1-1/2 LOCKNUT	2
10	106067	4 AWG GREEN/YELLOW WIRE x 14.00	1
11	125008	4/4 MAXI-LITE GENERATOR CORD	1
NS	113929	DECAL MAIN BREAKER ML II	1
NS	124713	11/15kW 50/60Hz 4/4 MAXI-LITE GENERATOR CORD SCHEMATIC	1

14.5 - 20kW 1PH Marathon Generator

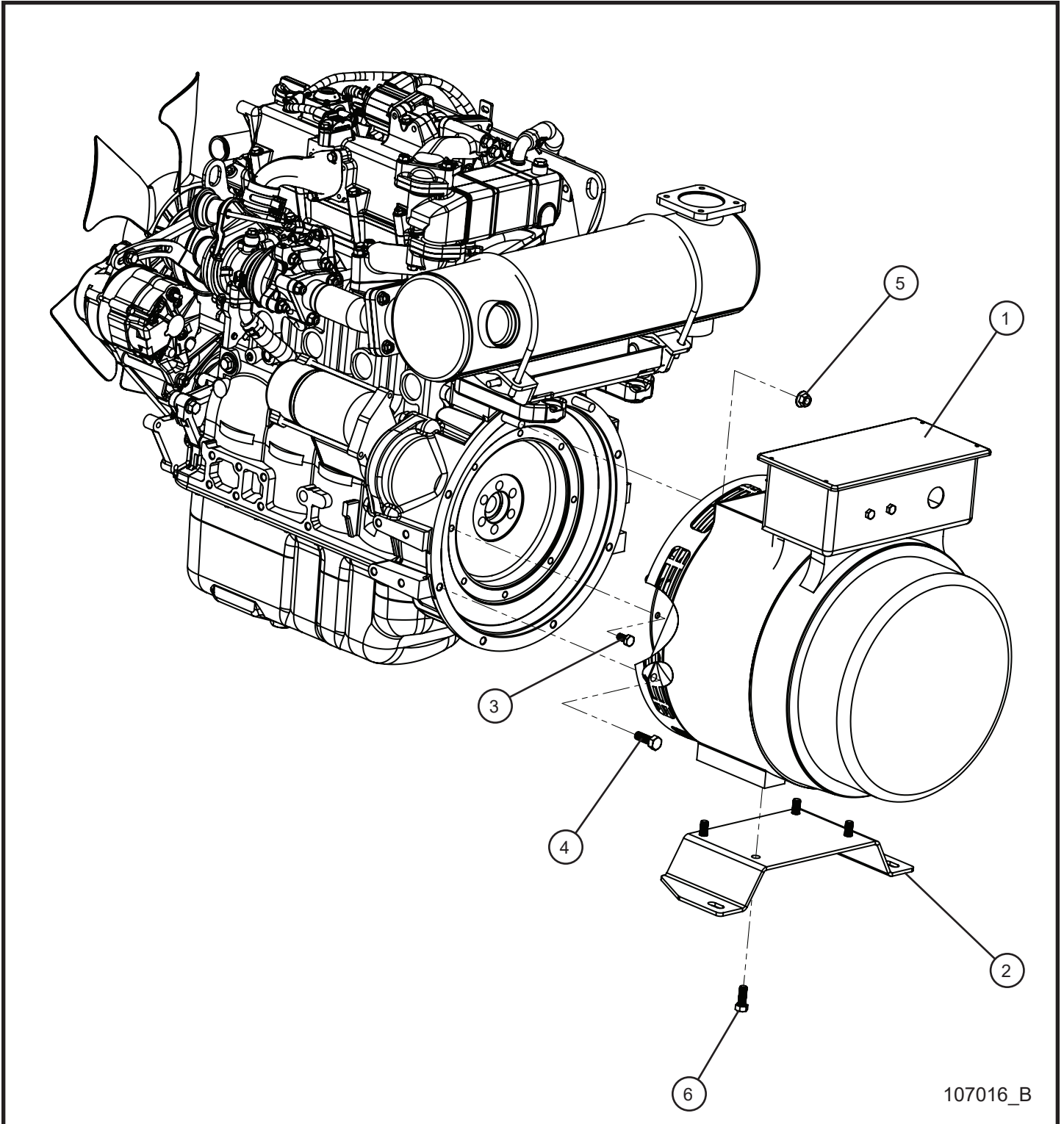

107016_B

14.5 - 20kW 1PH Marathon Generator

Item	Part No.	Part Description	Qty.
1	350356	20kW 1PH MARATHON GENERATOR	1
2	107017P	20kW MARATHON ISUZU 4LE2T GENERATOR MOUNT	1
3	055008	M8 x 1.25 x 16 HEX FLANGE SCREW W/ RED THREAD LOCK	8
4	055007	M10 x 1.5 x 30 HEX FLANGE BOLT W/ BLUE THREADLOCK	6
5	044029	3/8-16 SERRATED FLANGE NUT	2
6	056037	3/8-16 X 1 HEX FLANGE SCREW WITH BLUE THREAD LOCK	8

14.6 - 20kW 1PH Marathon Generator Cord Install Group

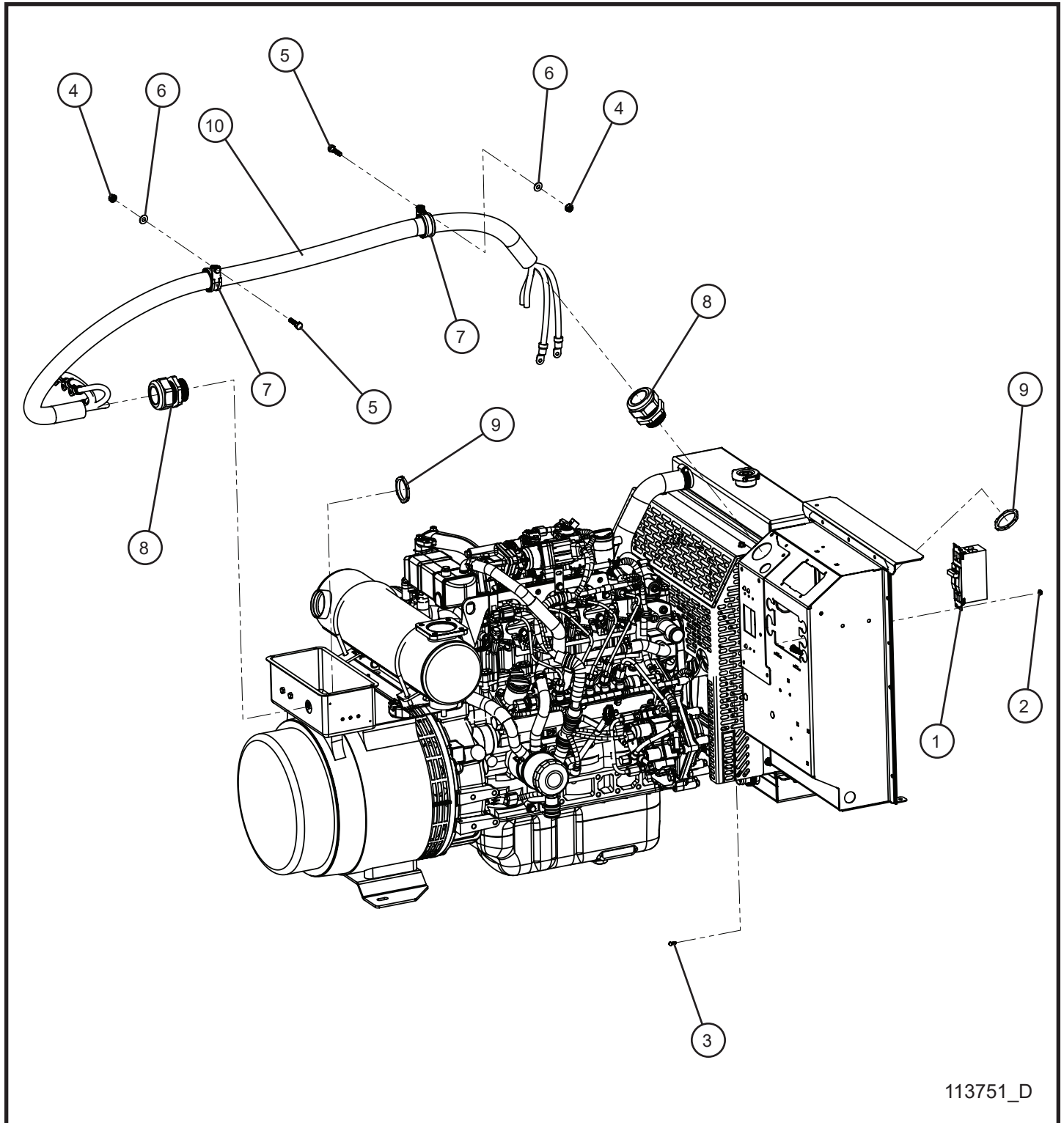

113751_D

14.6 - 20kW 1PH Marathon Generator Cord Install Group

Item	Part No.	Part Description	Qty.
1	353301	90 AMP DOUBLE POLE BREAKER	1
2	057003	#8-32 SERRATED FLANGE HEX LOCKNUT	4
3	056006	#8-32 X 1/2 SERRATED FLANGE HEX SCREW	4
4	044021	1/4-20 KEPS HEX HUT	2
5	046015	1/4-20 x 1 HEX HEAD BOLT	2
6	047009	1/4 FLAT WASHER	2
7	106144	1 1/2 CUSH CLAMP W/ 3/8 HOLE	2
8	105629	1-1/2 CORD GRIP	2
9	022232	1-1/2 LOCKNUT	2
10	125010	20kW 2/4 MAXI-LITE GENERATOR CORD	1
NS	113929	DECAL MAIN BREAKER ML II	1
NS	124715	20kW 1PH 2/4 MAXI-LITE GENERATOR CORD SCHEMATIC	1

14.7 - 20kW 1PH Linz Generator

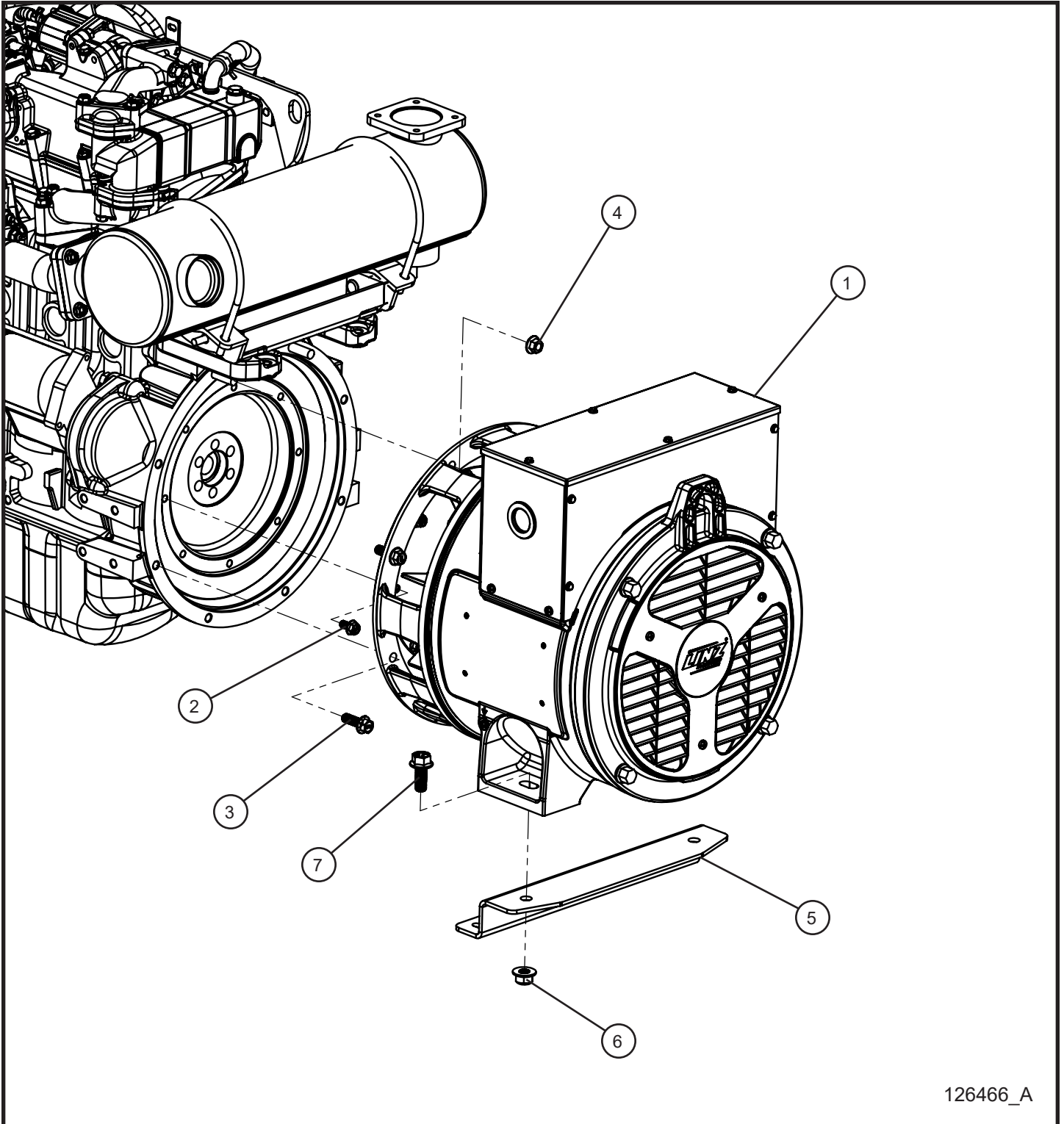

126466_A

14.7 - 20kW 1PH Linz Generator

Item	Part No.	Part Description	Qty.
1	125150	GENERATOR LINZ 20KW SINGLE PHASE 60 HZ AVR SAE 5 / 7.5	1
2	055008	M8 x 1.25 x 16 HEX FLANGE SCREW W/ RED THREAD LOCK	8
3	055007	M10 x 1.5 x 30 HEX FLANGE BOLT W/ BLUE THREADLOCK	6
4	044029	3/8-16 SERRATED FLANGE NUT	2
5	102794P	MOUNT GENERATOR 20 kW SINGLE PHASE LINZ	1
6	057009	1/2-13 HEX NYLOCK FLANGE NUT	2
7	056043	1/2-13 x 1 1/4 HEX FLANGE HEAD SCREW	2
NS	122041	HVR11 AVR MODULE	1

14.8 - 20kW 1PH Linz Generator Cord Install Group

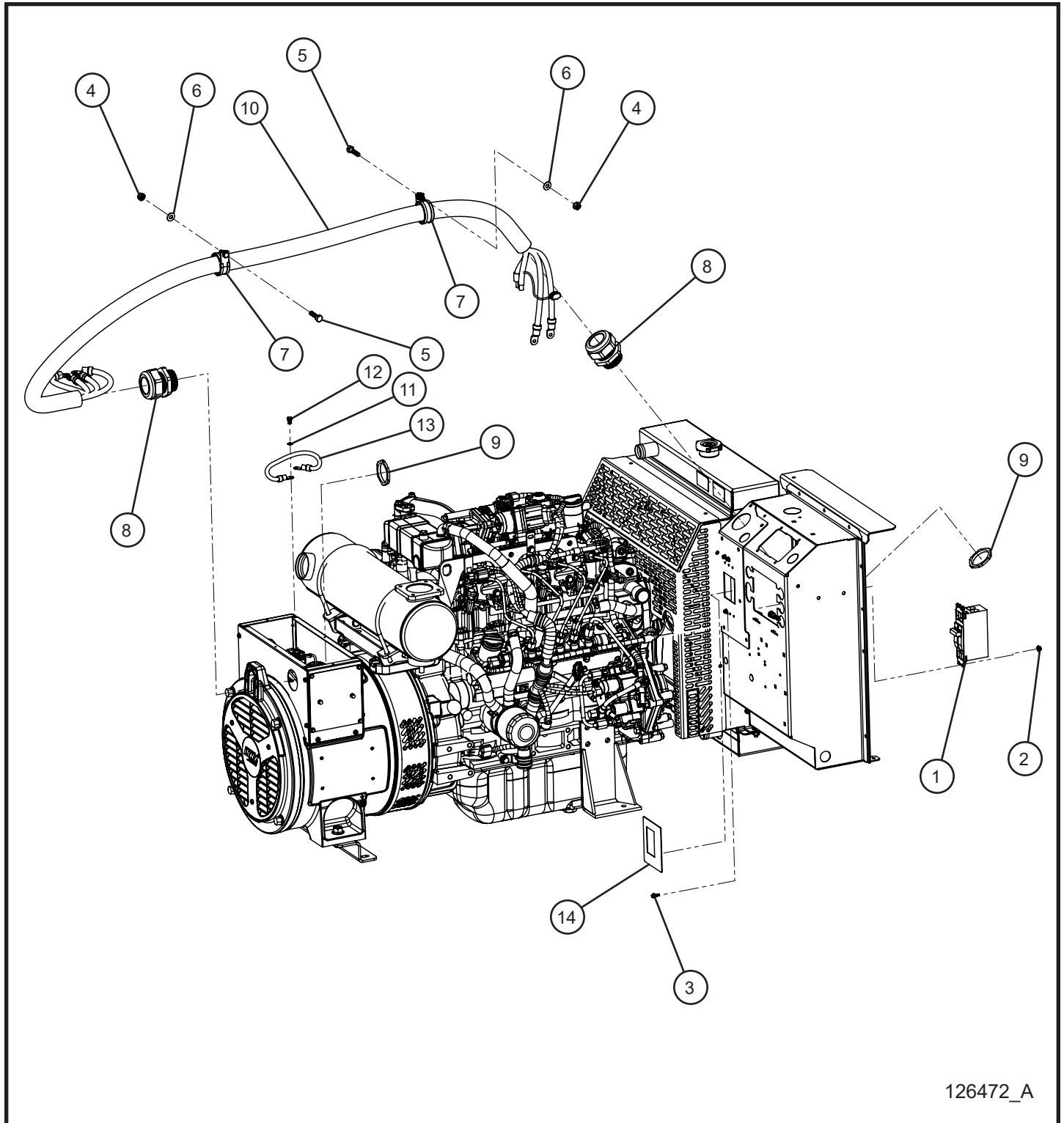

126472_A

14.8 - 20kW 1PH Linz Generator Cord Install Group

Item	Part No.	Part Description	Qty.
1	353301	90 AMP DOUBLE POLE BREAKER	1
2	057003	#8-32 SERRATED FLANGE HEX LOCKNUT	4
3	056006	#8-32 X 1/2 SERRATED FLANGE HEX SCREW	4
4	044021	1/4-20 KEPS HEX HUT	2
5	046015	1/4-20 x 1 HEX HEAD BOLT	2
6	047009	1/4 FLAT WASHER	2
7	106144	1 1/2 CUSH CLAMP W/ 3/8 HOLE	2
8	105629	1-1/2 CORD GRIP	2
9	022232	1-1/2 LOCKNUT	2
10	125010	2/4 GENERATOR CORD LINZ 20kW 1P MAXI II	1
11	043050	1/4 INTL TOOTH LOCK WASHER	1
12	042018	M6 x 1.0mm x 10mm HEX HEAD CS	1
13	126581	GENERATOR GROUND WIRE LINZ 20kW	1
14	113929	DECAL MAIN BREAKER ML II	1
NS	124715	20kW 1PH 2/4 MAXI-LITE GENERATOR CORD SCHEMATIC	1

14.9 - 20kW 3PH Coliseum Generator

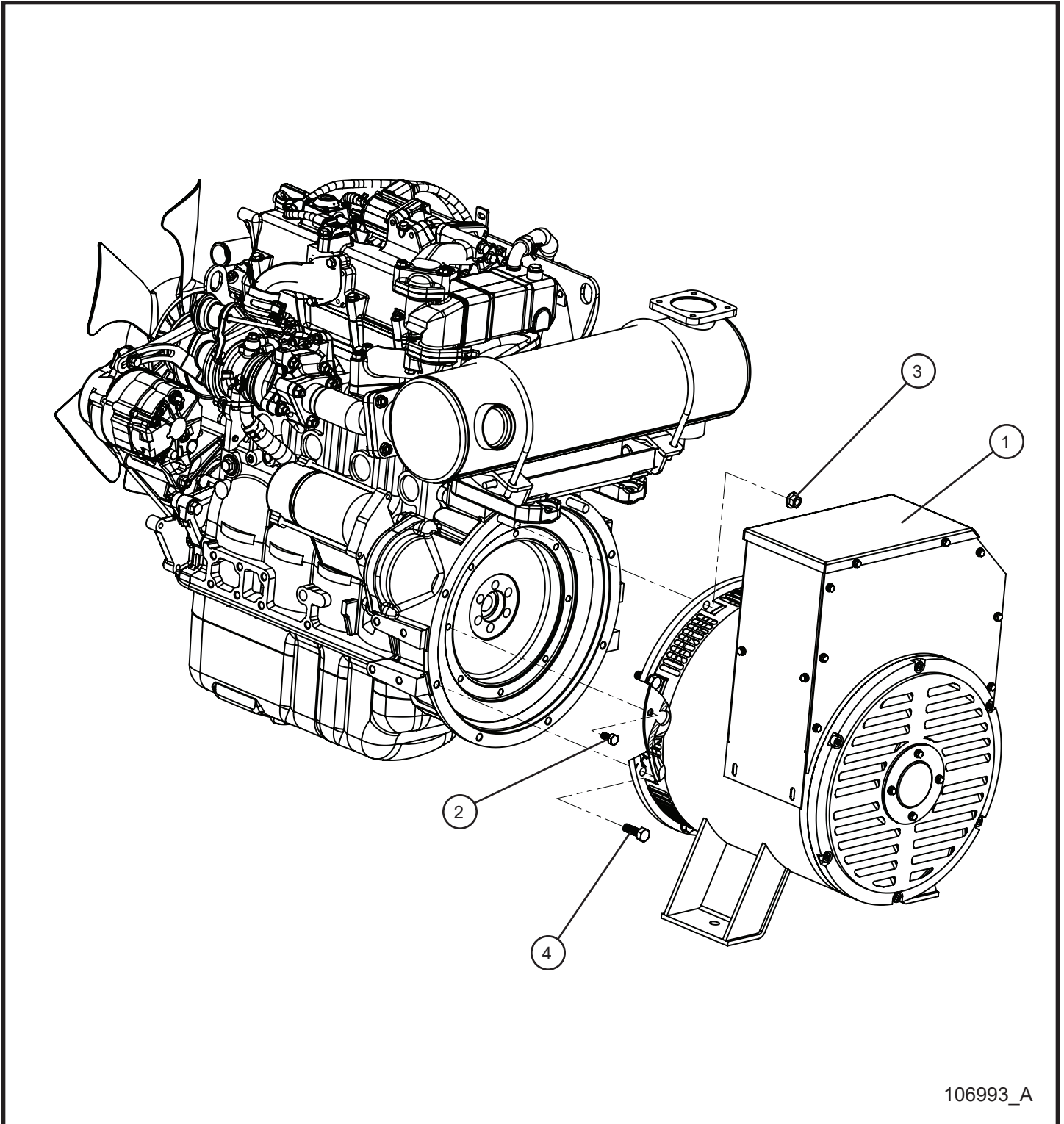

106993_A

14.9 - 20kW 3PH Coliseum Generator

Item	Part No.	Part Description	Qty.
1	126287	20kW 3PH AVR 60Hz COLISEUM GENERATOR SUBASSEMBLY	1
2	055008	M8 x 1.25 x 16 HEX FLANGE SCREW W/ RED THREAD LOCK	8
3	044029	3/8-16 SERRATED FLANGE NUT	2
4	055007	M10 x 1.5 x 30 HEX FLANGE BOLT W/ BLUE THREADLOCK	6
NS	103880	MARATHON AVR FOR 350356	1
NS	121273	#8-32 x 1 PH-PAN HEAD	2
NS	057003	#8-32 SERRATED FLANGE HEX LOCKNUT	2

14.10 - 20kW 3PH Coliseum Generator Cord Install Group

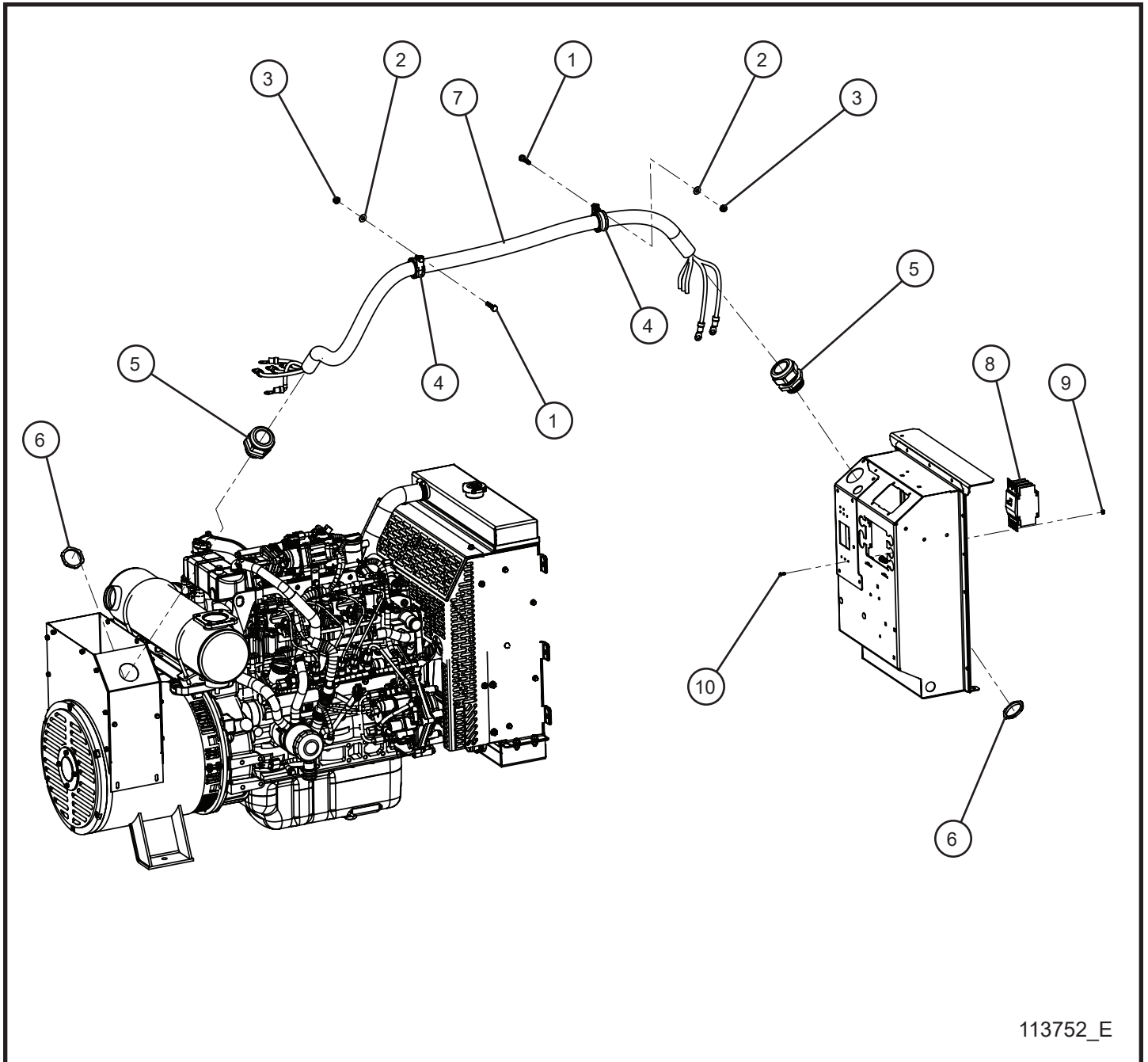

113752_E

14.10 - 20kW 3PH Coliseum Generator Cord Install Group

Item	Part No.	Part Description	Qty.
1	046015	1/4-20 x 1 HEX HEAD BOLT	2
2	047009	1/4 FLAT WASHER	2
3	044021	1/4-20 KEPS HEX NUT	2
4	106144	1 1/2 CUSH CLAMP W/ 3/8 HOLE	2
5	105629	1-1/2 NYLON BLACK CORD GRIP	2
6	022232	1 1/2 LOCKNUT	2
7	125009	4/5 208V CSA GENERATOR CORD	1
8	022235	60A 3 POLE BREAKER	1
9	057003	#8-32 SERRATED FLANGE HEX LOCKNUT	4
10	056006	#8-32 X 1/2 SERRATED FLANGE HEX SCREW	4
NS	113929	DECAL MAIN BREAKER ML II	1
NS	124714	20kW 3PH COLISEUM MAXI-LITE SCHEMATIC	1

15.1 - Door Branding Decals

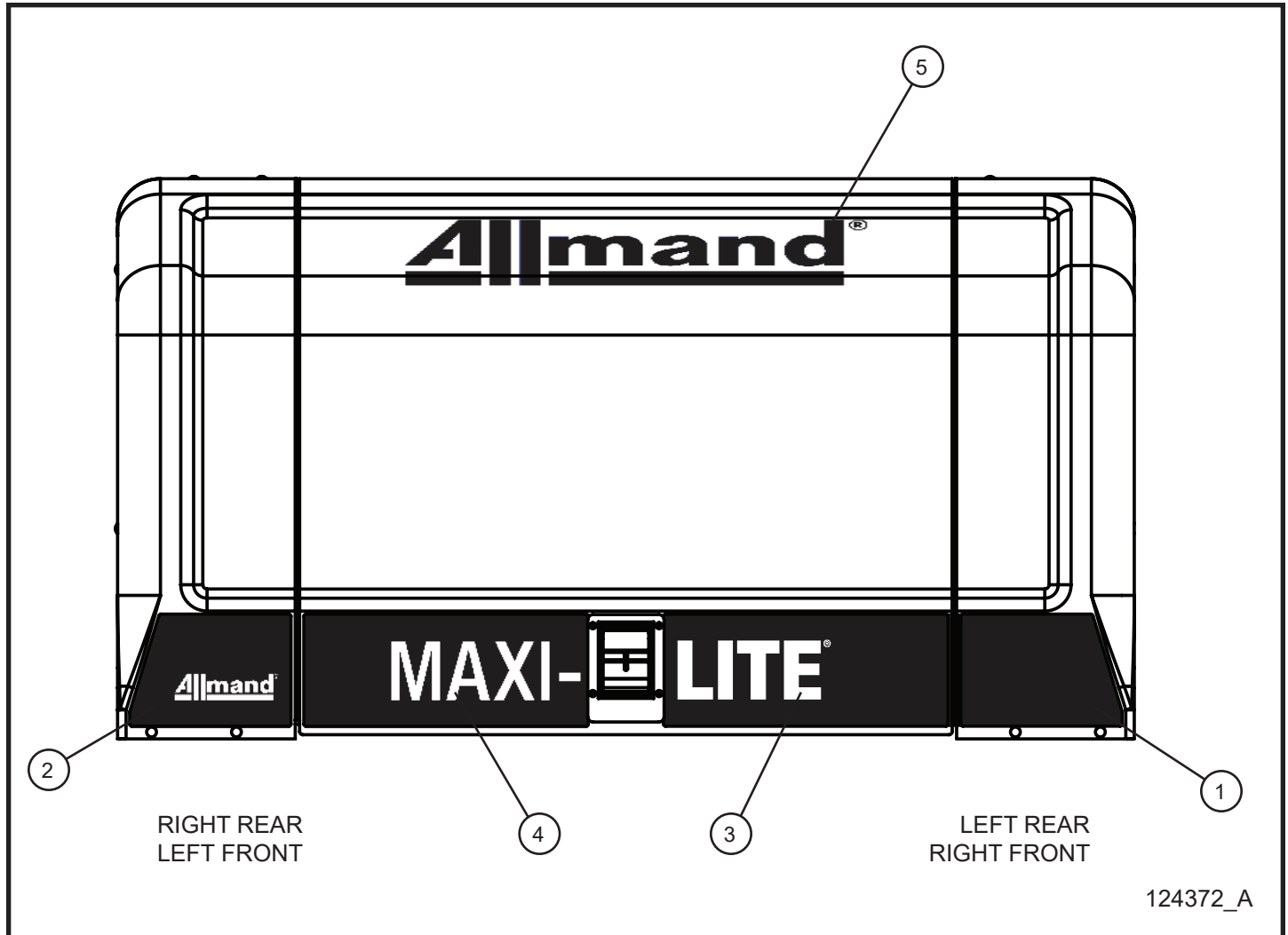

15.1 - Door Branding Decals

Item	Part No.	Part Description	Qty.
1	122997	DECAL BLANK QUARTER PANEL STRIPE MAXI	2
2	118343	DECAL ALLMAND LEFT HAND DOOR STRIPE MAXI DOOR	2
3	122996	DECAL LITE DOOR STRIPE MAXI-LITE	2
4	118345	DECAL MAXI- LEFT HAND DOOR STRIPE MAXI DOOR	2
5	118119	DECAL BRANDING ALLMAND-R BLACK 23.3 INCH	2
	118425	DECAL BRANDING ALLMAND-R GOLD-WHITE 23.3 INCH	2

NS - Not Shown

* * * - Contact Allmand for more information.

15.2 - Domestic English/French Safety Decals (1 of 6)

2	1	3	4	5	
 WARNING Failure to follow warnings, instructions, and operator's manual could result in death or serious injury. AVERTISSEMENT L'omission de respecter les avertissements, les instructions et le manuel d'utilisation pourrait entraîner des blessures graves ou la mort.	 WARNING Read and follow operator's manual before operating or servicing this equipment. AVERTISSEMENT Lire et suivre le manuel d'utilisation avant de faire fonctionner ou de faire l'entretien de cet équipement.	 WARNING Unexpected start of engine could result in death or serious injury. AVERTISSEMENT Le démarrage inattendu de moteur pourrait provoquer la mort ou des blessures graves.	 WARNING Read and follow electronic controller operator's manual before operating or servicing this equipment. AVERTISSEMENT Lire et suivre le manuel d'utilisation du contrôleur électronique avant d'utiliser ou de réparer cet équipement.	 WARNING Contact with hot exhaust gases and parts could cause serious injury. AVERTISSEMENT Tout contact avec les pièces et les gaz d'échappement chauds pourrait causer la mort ou des blessures graves.	 WARNING Avoid hot exhaust gases. Keep hands and combustible materials away from hot parts. AVERTISSEMENT Éviter les gaz d'échappement chauds. Tenir les mains et les produits inflammables à l'écart des pièces chaudes.
 WARNING Contact with rotating parts could result in death or serious injury. AVERTISSEMENT Le contact avec des pièces en mouvement pourrait causer la mort ou des blessures graves.	 WARNING Keep away from rotating parts. AVERTISSEMENT Se tenir à l'écart des pièces en mouvement.	 WARNING Opening cap on hot radiator could result in death or serious injury. AVERTISSEMENT L'ouverture du bouchon sur un radiateur chaud pourrait causer la mort ou des blessures graves.	 WARNING Allow radiator to cool down before opening cap. AVERTISSEMENT Laissez le radiateur refroidir avant de dévisser le bouchon.	 WARNING Exposure to corrosive material could result in death or serious injury. AVERTISSEMENT Toute exposition à des produits corrosifs pourrait causer la mort ou des blessures graves.	 WARNING Wear protective gloves when handling battery. AVERTISSEMENT Porter des gants de protection en manipulant la batterie.
 WARNING Smoking materials, open flames, or other forms of ignition could cause equipment resulting in death or serious injury. AVERTISSEMENT Les articles de fumées, les flammes nues ou les autres formes d'allumage à l'écart de la batterie.	 WARNING Keep smoking materials, open flames, and other forms of ignition away from the battery. AVERTISSEMENT Tenir les articles de fumées, les flammes nues ou les autres formes d'allumage à l'écart de la batterie.	 NOTICE Neutral bonded to frame. Machine to be grounded in accordance with requirements as outlined by local inspection authorities. AVIS Neutre mis à la masse à la carcasse du moteur. L'appareil doit être mis à la terre conformément aux exigences des services d'inspection locaux.			

LEFT SIDE

120917_B

15.2 - Domestic English Safety Decals (1 of 6)

Item	Part No.	Part Description	Qty.
1	118074	DECAL BILINGUAL DANGER HAZARDOUS VOLTAGE VERTICAL	1
2	122467	DECAL MULTIPLE WARNINGS DOOR	1
3	122470	DECAL NOTICE NEUTRAL BONDED & GROUNDED	1
4	107254	FORKLIFT POSITION DECAL	2
5	109005	TIE DOWN POSITION DECAL	2

15.2 - Domestic English/French Safety Decals (2 of 6)

<p>⚠ WARNING</p> <p>Failure to follow warnings, instructions, and operator's manual could result in death or serious injury.</p> <p>⚠ AVERTISSEMENT</p> <p>L'omission de respecter les avertissements, les instructions et le manuel de l'utilisateur peuvent entraîner des blessures graves ou la mort.</p>	<p>⚠ WARNING</p> <p>Read and follow operator's manual before operating or servicing this equipment.</p> <p>⚠ AVERTISSEMENT</p> <p>Lire et suivre le manuel d'utilisation avant de faire fonctionner ou de faire l'entretien de cet équipement.</p>	<p>⚠ WARNING</p> <p>Unexpected start of engine could result in death or serious injury.</p> <p>⚠ AVERTISSEMENT</p> <p>Le démarrage inattendu du moteur pourrait provoquer la mort ou des blessures graves.</p>	<p>⚠ WARNING</p> <p>Read and follow electronic controller operator's manual before operating or servicing the equipment.</p> <p>⚠ AVERTISSEMENT</p> <p>Lire et suivre le manuel d'utilisation du contrôleur électronique avant d'utiliser ou de réparer cet équipement.</p>	<p>⚠ WARNING</p> <p>Contact with hot exhaust gases and parts could cause serious injury.</p> <p>⚠ AVERTISSEMENT</p> <p>Tout contact avec les pièces et les gaz d'échappement chauds pourrait causer la mort ou des blessures graves.</p>	<p>⚠ WARNING</p> <p>Avoid hot exhaust gases. Keep hands and combustible materials away from hot parts.</p> <p>⚠ AVERTISSEMENT</p> <p>Éviter les gaz d'échappement chauds. Tenir les mains et les produits inflammables à l'écart des pièces chaudes.</p>	<p>⚠ WARNING</p> <p>Contact with rotating parts could result in death or serious injury.</p> <p>⚠ AVERTISSEMENT</p> <p>Le contact avec des pièces en mouvement pourrait résulter en de graves blessures voire la mort.</p>	<p>⚠ WARNING</p> <p>Keep away from rotating parts.</p> <p>⚠ AVERTISSEMENT</p> <p>Se tenir à l'écart des pièces en mouvement.</p>	<p>⚠ WARNING</p> <p>Opening cap on hot radiator could result in death or serious injury.</p> <p>⚠ AVERTISSEMENT</p> <p>L'ouverture du bouchon sur un radiateur chaud pourrait causer la mort ou des blessures graves.</p>	<p>⚠ WARNING</p> <p>Allow radiator to cool down before opening cap.</p> <p>⚠ AVERTISSEMENT</p> <p>Laissez le radiateur refroidir avant de dévisser le bouchon.</p>	<p>⚠ WARNING</p> <p>Exposure to caustic material could result in death or serious injury.</p> <p>⚠ AVERTISSEMENT</p> <p>Toute exposition à des produits caustiques pourrait causer la mort ou des blessures graves.</p>	<p>⚠ WARNING</p> <p>Wear protective gloves when handling battery.</p> <p>⚠ AVERTISSEMENT</p> <p>Porter des gants de protection en manipulant la batterie.</p>	<p>⚠ WARNING</p> <p>Smoking materials, open flames, or other forms of ignition near the battery could cause explosion resulting in death or serious injury.</p> <p>⚠ AVERTISSEMENT</p> <p>Les articles de fumure, les flammes nues ou les autres formes d'allumage à l'écart de la batterie.</p>	<p>⚠ WARNING</p> <p>Keep smoking materials, open flames, and other forms of ignition away from the battery.</p> <p>⚠ AVERTISSEMENT</p> <p>Tenir les articles de fumure, les flammes nues ou les autres formes d'allumage à l'écart de la batterie.</p>
--	--	--	---	--	--	--	--	---	--	---	---	--	--

122487

1

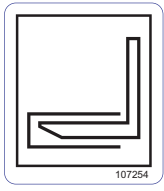

2

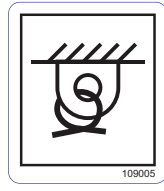

3

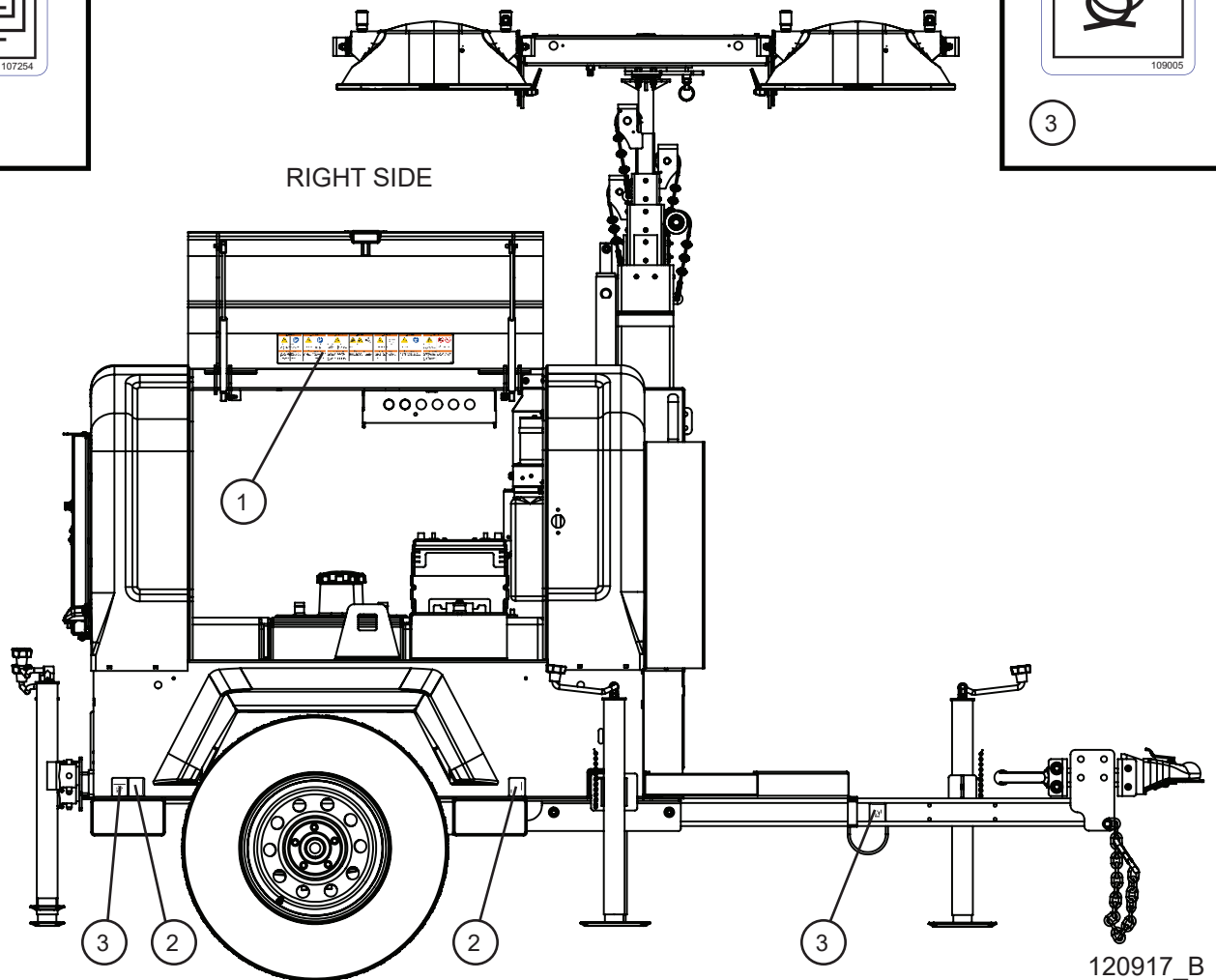

15.2 - Domestic English/French Safety Decals (2 of 6)

Item	Part No.	Part Description	Qty.
1	122467	DECAL MULTIPLE WARNINGS DOOR	1
2	107254	FORKLIFT POSITION DECAL	2
3	109005	TIE DOWN POSITION DECAL	2

15.2 - Domestic English/French Safety Decals (3 of 6)

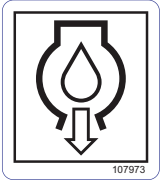

1

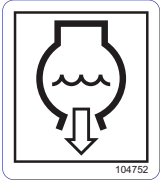

3

<p>⚠ WARNING</p> <p>Opening cap on hot radiator could result in death or serious injury.</p> <p>Allow radiator to cool down before opening cap.</p>		<p>⚠ AVERTISSEMENT</p> <p>L'ouverture du bouchon sur un radiateur chaud pourrait causer la mort ou des blessures graves.</p> <p>Laisser le radiateur refroidir avant de dévisser le bouchon.</p>
--	--	---

118651

6



4

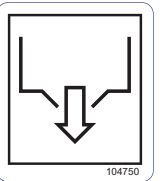

2



5

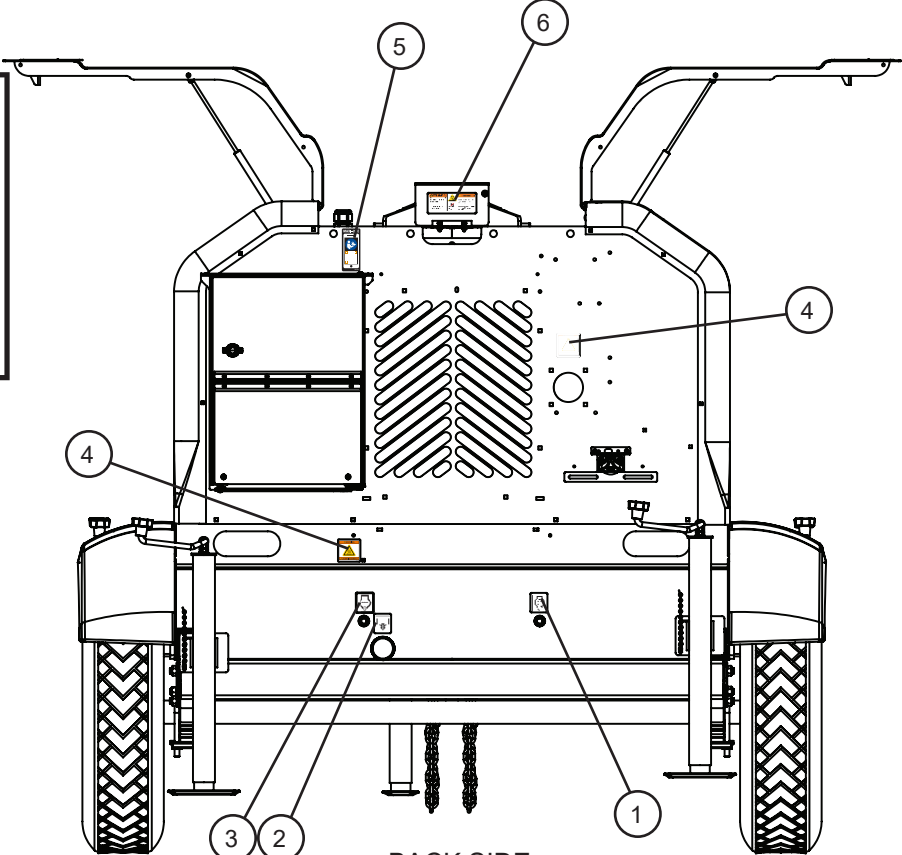

BACK SIDE

120917_B

15.2 - Domestic English Safety Decals (3 of 6)

Item	Part No.	Part Description	Qty.
1	107973	OIL DRAIN DECAL	1
2	107971	DRAIN FLUID CONTAINMENT DECAL	1
3	104752	DRAIN ENGINE COOLANT DECAL	1
4	118162	DECAL WARNING HOT SURFACE ENGLISH & FRENCH	2
5	123247	DECAL QR CODE MAXI-LITE	1
6	118651	DECAL RADIATOR WARNING BI-LINGUAL	1

15.2 - Domestic English Safety Decals (4 of 6)

<p>⚠ WARNING Standing under light tower mist and fixtures during lowering operation could result in death or serious injury.</p> <p>Keep bystanders away from light tower during lowering and raising operations.</p> <p>⚠ AVERTISSEMENT Le fait de se tenir debout sous une tour d'éclairage et de ses accessoires alors qu'elle est abaissée pourrait causer la mort ou des blessures graves.</p> <p>Tenir les spectateurs à l'écart de la tour d'éclairage pendant qu'on la souève ou l'abaisse.</p> <p>⚠ WARNING Handling light fixtures when they are hot could result in death or serious injury.</p> <p>Keep clear of light fixtures when illuminated or hot.</p> <p>⚠ AVERTISSEMENT La manipulation des luminaires alors qu'ils sont chauds pourrait causer la mort ou des blessures graves.</p> <p>Restez à l'écart des luminaires lorsqu'ils sont allumés ou chauds.</p> <p>⚠ WARNING Looking at illuminated light fixtures could result in serious injury.</p> <p>Do not look directly at illuminated light fixtures.</p> <p>⚠ AVERTISSEMENT Regardez des luminaires allumés pourrait provoquer de graves blessures.</p> <p>Ne jamais regarder directement des luminaires allumés.</p> <p>122478</p>	<p>1</p> <p>TOP OF THE LIGHT BAR</p>	<p>⚠ WARNING</p> <p>Failure to follow warnings, instructions, and operator's manual could result in death or serious injury.</p> <p>Read and follow operator's manual before operating or servicing this equipment.</p> <p>⚠ AVERTISSEMENT L'omission de respecter les avertissements, les instructions et le manuel de l'utilisateur pourrait entraîner des blessures graves ou la mort.</p> <p>Lire et suivre le manuel d'utilisation avant de faire fonctionner ou de faire l'entretien de cet équipement.</p> <p>⚠ WARNING</p> <p>Failure to lower tower into a secured position before towing could result in death or serious injury.</p> <p>Lower tower to a secured position before towing.</p> <p>⚠ AVERTISSEMENT Ne pas abaisser la tour d'éclairage en position sécurisée au préalable peut provoquer la mort ou des blessures graves.</p> <p>Abaissant la tour en position sécurisée avant le remorquage.</p> <p>⚠ WARNING</p> <p>Excessive towing speed could result in death or serious injury.</p> <p>Do not exceed 65mph (105km/h) when towing trailer.</p> <p>⚠ AVERTISSEMENT Une vitesse de remorquage excessive pourrait entraîner la mort ou de graves blessures.</p> <p>Ne pas dépasser 105 km/h (65 mi/h) lors du remorquage.</p> <p>122483</p>
<p>2</p> <p>120917_B</p> <p>4</p> <p>LIFT POINT LEFT SIDE DETAIL</p> <p>3</p> <p>TOP FRONT DETAIL</p> <p>5</p> <p>LIFT POINT RIGHT SIDE DETAIL</p>	<p>5</p> <p>TOWER DETAIL</p>	<p>3</p> <p>5</p> <p>122480</p>
	<p>⚠ WARNING</p> <p>116044</p> <p>4</p>	<p>⚠ DANGER</p> <p>118074</p> <p>1</p>

15.2 - Domestic English Safety Decals (4 of 6)

Item	Part No.	Part Description	Qty.
1	118074	DECAL BILINGUAL DANGER HAZARDOUS VOLTAGE VERTICAL	1
2	122478	VERTICAL TOWER DECAL PRO II/ MAXI II	1
3	122463	LIGHT TOWER UNIVERSAL WARNING TONGUE DECAL	1
4	116044	DECAL WARNING SURFACE HOT	1
5	122480	DECAL LIFT HOOK	2

15.2 - Domestic English Safety Decals (5 of 6)

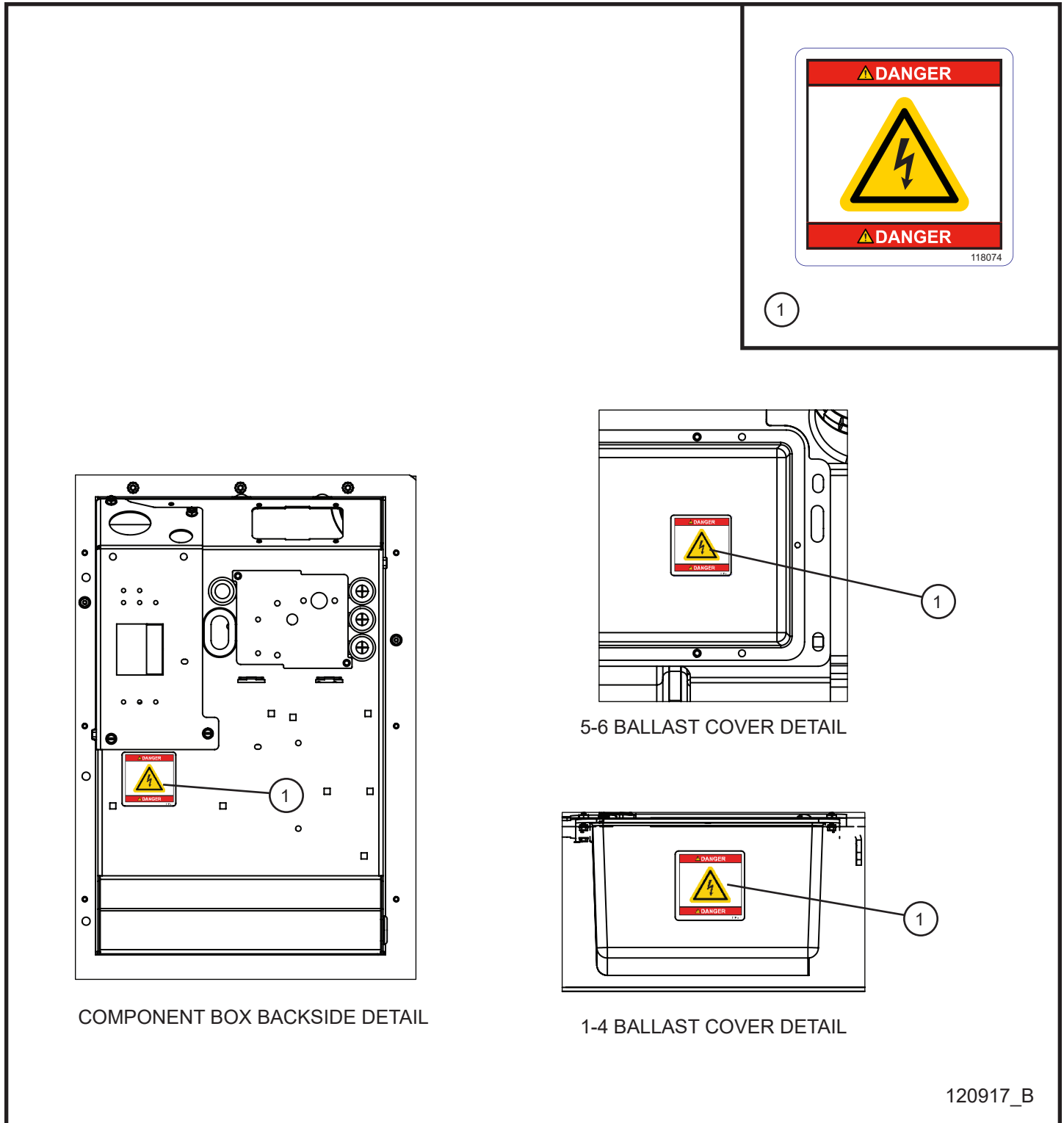

15.2 - Domestic English Safety Decals (5 of 6)

Item	Part No.	Part Description	Qty.
1	118074	DECAL BILINGUAL DANGER HAZARDOUS VOLTAGE VERTICAL	1

15.2 - Domestic English Safety Decals (6 of 6)

118074

<p>WARNING</p> <p>Failure to follow warnings, instructions, and operator's manual could result in death or serious injury.</p>	<p>AVERTISSEMENT</p> <p>L'omission de respecter les avertissements, les instructions et le manuel de l'utilisateur pourrait entraîner des blessures graves ou la mort.</p>	<p>DANGER</p> <p>Contacting power lines when raising light tower will result in death or serious injury.</p>	<p>DANGER</p> <p>Le contact avec une ligne électrique lorsque la tour d'éclairage est levée entraînera des blessures graves ou la mort.</p>	<p>WARNING</p> <p>Standing under light tower mast and fixtures during lowering operation could result in death or serious injury.</p>	<p>AVERTISSEMENT</p> <p>Le fait de se tenir debout sous une tour d'éclairage et de ses accessoires alors qu'elle est abaissée pourrait causer la mort ou des blessures graves.</p>
<p>WARNING</p> <p>Read and follow operator's manual before operating or servicing this equipment.</p>	<p>AVERTISSEMENT</p> <p>Lire et suivre le manuel d'utilisation avant de faire fonctionner ou de faire l'entretien de cet équipement.</p>	<p>WARNING</p> <p>Keep light tower far away from power lines.</p>	<p>AVERTISSEMENT</p> <p>Tenir la tour d'éclairage éloignée des lignes électriques.</p>	<p>WARNING</p> <p>Keep bystanders away from light tower during lowering and raising operations.</p>	<p>AVERTISSEMENT</p> <p>Tenir les spectateurs à l'écart de la tour d'éclairage pendant qu'on la soulève ou l'abaisse.</p>
<p>WARNING</p> <p>Raising light tower prior to positioning outriggers and lowering jacks could cause machine rollover resulting in death or serious injury.</p>	<p>AVERTISSEMENT</p> <p>Le fait de soulever la tour d'éclairage avant de positionner correctement les longrines et de baisser les vérins pourrait entraîner le basculement de la machine et provoquer des blessures graves ou la mort.</p>	<p>WARNING</p> <p>Engine exhaust contains carbon monoxide, a poisonous gas that could cause death or serious injury.</p>	<p>AVERTISSEMENT</p> <p>Le moteur contient du monoxyde de carbone, un gaz toxique pouvant provoquer la mort ou de graves blessures.</p>	<p>WARNING</p> <p>Breathing diesel engine exhaust fumes may be harmful to health. Diesel engine exhaust contains chemicals known to the State of California to cause cancer and birth defects or other reproductive harm.</p>	<p>AVERTISSEMENT</p> <p>L'inspiration de gaz d'échappement du moteur vous expose aux produits chimiques connus selon l'État de Californie pour causer le cancer, les anomalies congénitales ou d'autres effets reproductifs.</p>
<p>WARNING</p> <p>Position outriggers and lower jacks on a stable surface before raising light tower.</p>	<p>AVERTISSEMENT</p> <p>Il faut positionner les longrines et abaisser les vérins sur une surface stable avant de lever la tour d'éclairage.</p>	<p>WARNING</p> <p>Run equipment far from windows, doors and vents. Do not run equipment indoors or in partially enclosed spaces.</p>	<p>AVERTISSEMENT</p> <p>Faites tourner à l'extérieur, loin des fenêtres, des portes et des vents. Ne faites pas fonctionner à l'intérieur ni dans un espace partiellement fermé.</p>	<p>WARNING</p> <p>Always start and operate the engine in a well-ventilated area. If in an enclosed area, vent the exhaust to the outside. Do not modify or tamper with the exhaust system. Do not start the engine except as necessary.</p>	<p>AVERTISSEMENT</p> <p>Toujours démarrer et faire fonctionner le moteur dans un endroit bien ventilé. Si le moteur est utilisé dans un espace fermé, ventiler les gaz d'échappement à l'extérieur. Ne pas modifier ni altérer le système d'échappement. Ne pas mettre le moteur au ralenti sauf en cas de nécessité.</p>

122477

120917_B

CONTROL PANEL DOOR INTERIOR

15.2 - Domestic English Safety Decals (6 of 6)

Item	Part No.	Part Description	Qty.
1	122469	DECAL WARNINGS MAXI-LITE & NLV CONTROL BOX	1
2	122477	START INSTRUCTIONS DECAL	1
3	118074	DECAL BILINGUAL DANGER HAZARDOUS VOLTAGE VERTICAL	1

15.3 - International Wordless Safety Decals (1 of 6)

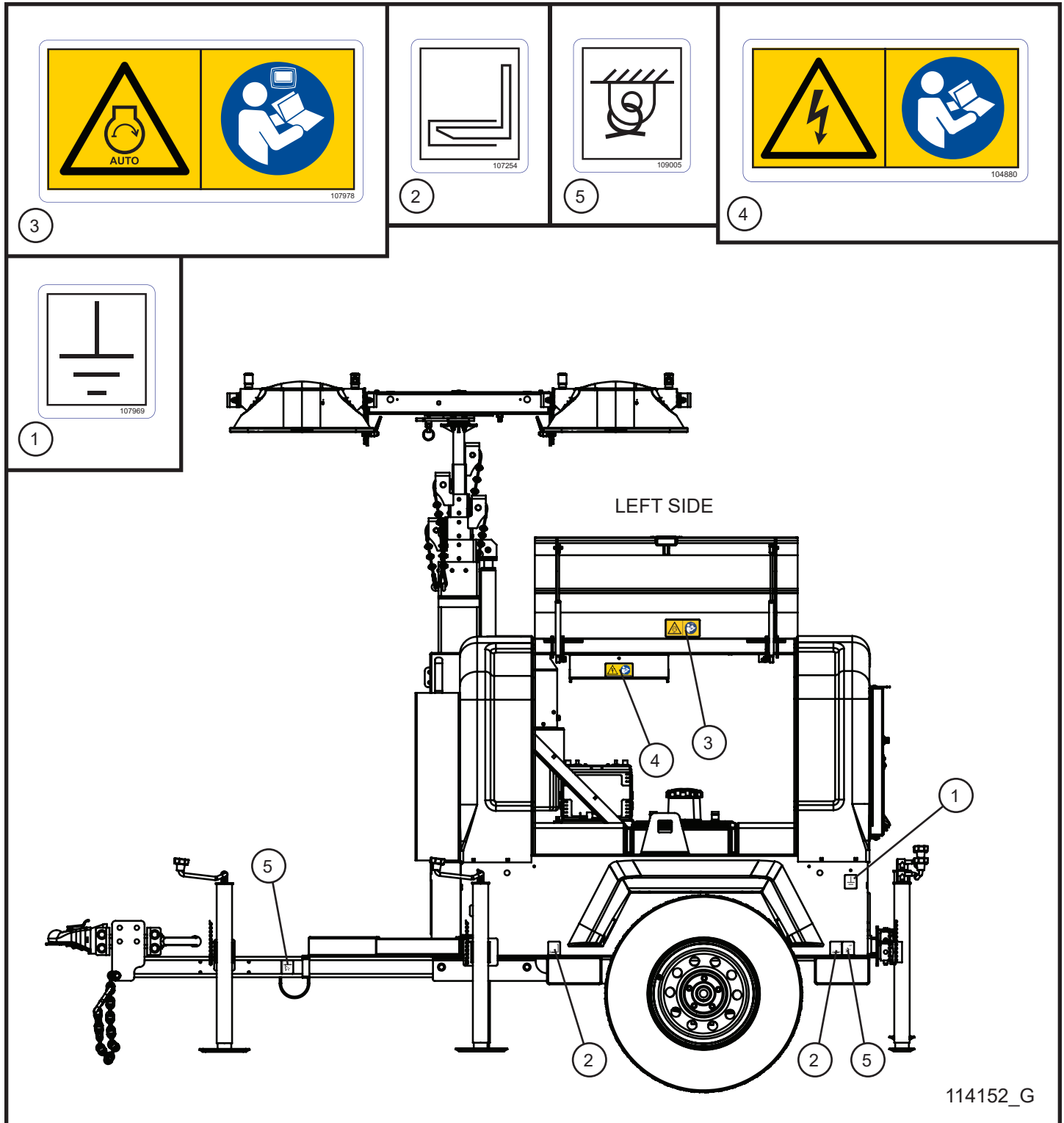

114152_G

15.3 - International Wordless Safety Decals (1 of 6)

Item	Part No.	Part Description	Qty.
1	107969	GROUND POSITION DECAL	1
2	107254	FORKLIFT POSITION DECAL	2
3	107978	WORDLESS LSC ENGINE WARNING DECAL	1
4	104880	WORDLESS HIGH VOLTAGE DECAL	1
5	109005	TIE DOWN POSITION DECAL	2

15.3 - International Wordless Safety Decals (2 of 6)

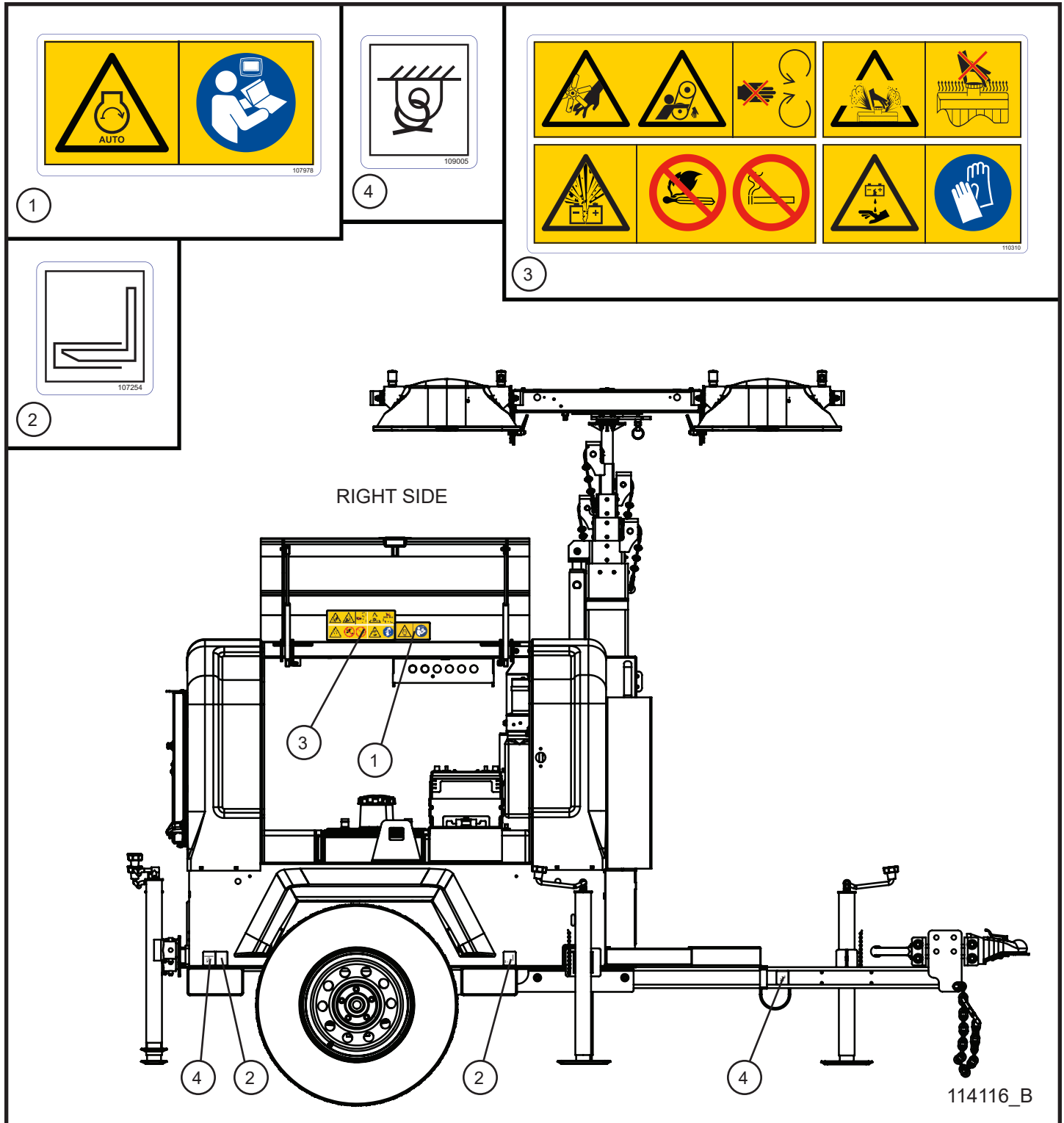

15.3 - International Wordless Safety Decals (2 of 6)

Item	Part No.	Part Description	Qty.
1	107978	WORDLESS LSC ENGINE WARNING DECAL	1
2	107254	FORKLIFT POSITION DECAL	2
3	110310	WORDLESS ENGINE-RADIATOR-BATTERY WARNING DECAL	1
4	109005	TIE DOWN POSITION DECAL	2

15.3 - International Wordless Safety Decals (3 of 6)

110389

8

104880

6

104750

2

107973

1

107529

4

104752

3

112163

5

BACK SIDE

MAXI-LITE

123247

7

114116_B

15.3 - International Wordless Safety Decals (3 of 6)

Item	Part No.	Part Description	Qty.
1	107973	OIL DRAIN DECAL	1
2	107971	DRAIN FLUID CONTAINMENT DECAL	1
3	104752	DRAIN ENGINE COOLANT DECAL	1
4	107529	WORDLESS HOT SURFACE WARNING DECAL	2
5	112163	MAXI-LITE CONTROL DOOR WORDLESS WARNING DECAL	1
6	104880	WORDLESS HIGH VOLTAGE DECAL	1
7	123247	DECAL QR CODE MAXI-LITE	1
8	122091	DECAL WARNING RADIATOR WORDLESS	1

15.3 - International Wordless Safety Decals (4 of 6)

107980

4

TOP OF THE LIGHT BAR

107408

116045

5

LIFT POINT LEFT SIDE DETAIL

104880

104880

1

VERTICAL TOWER FRONT DETAIL

122480

2

TOP FRONT DETAIL

5

LIFT POINT RIGHT SIDE DETAIL

107408

15.3 - International Wordless Safety Decals (4 of 6)

Item	Part No.	Part Description	Qty.
1	107980	WORDLESS 3 PANEL VERTICAL TOWER WARNING DECAL	1
2	116045	WORDLESS SMALL HOT SURFACE WARNING DECAL	1
3	107458	WORDLESS VERTICAL TOWER TOWING WARNING DECAL	1
4	104880	WORDLESS HIGH VOLTAGE DECAL	1
5	122480	DECAL LIFT HOOK	2

15.3 - International Wordless Safety Decals (5 of 6)

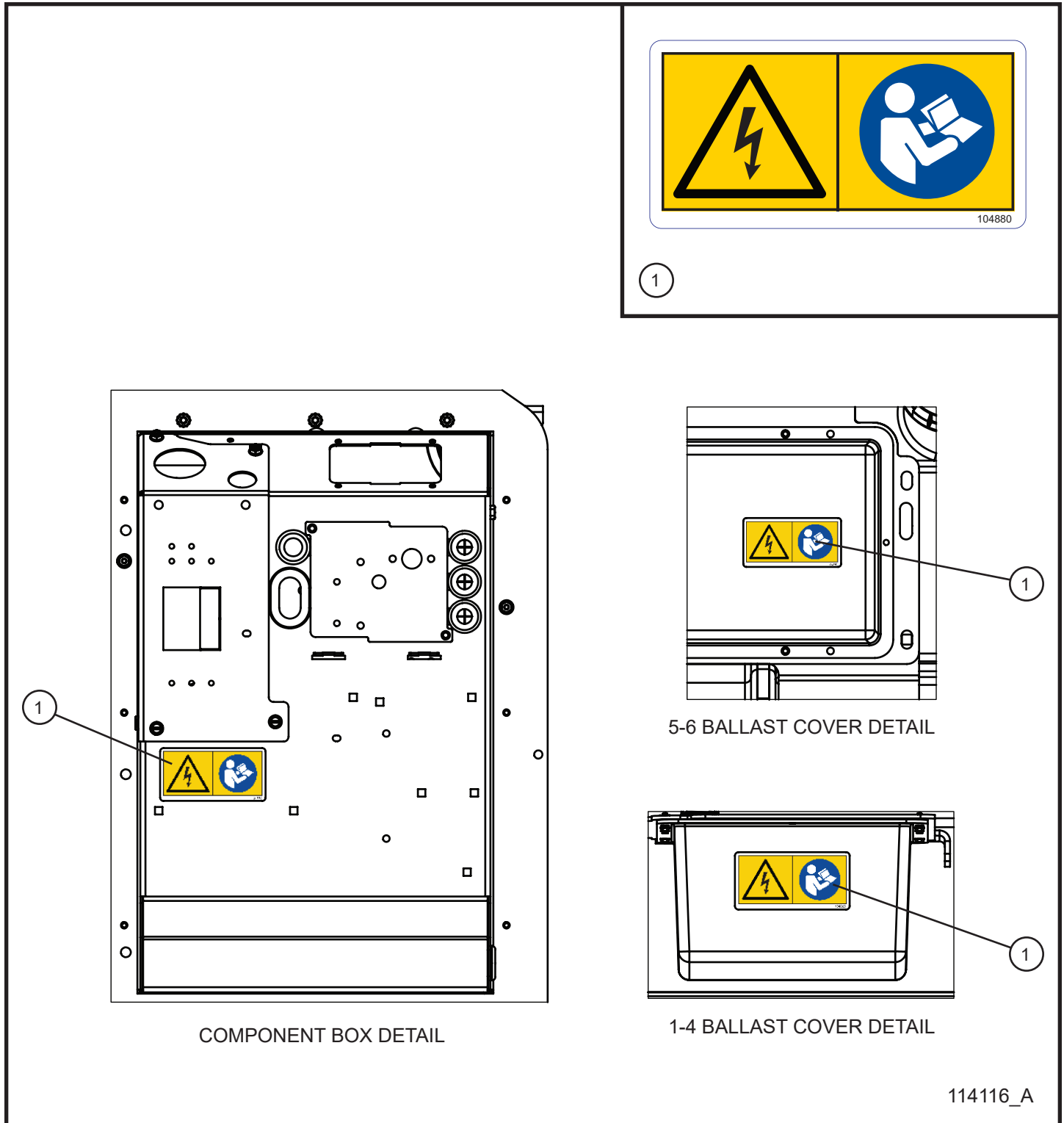

114116_A

15.3 - International Wordless Safety Decals (5 of 6)

Item	Part No.	Part Description	Qty.
1	104880	WORDLESS HIGH VOLTAGE DECAL	3
2	109012	WORDLESS HAZARDOUS VOLTAGE VERTICAL DANGER DECAL	1

15.3 - International Wordless Safety Decals (6 of 6)

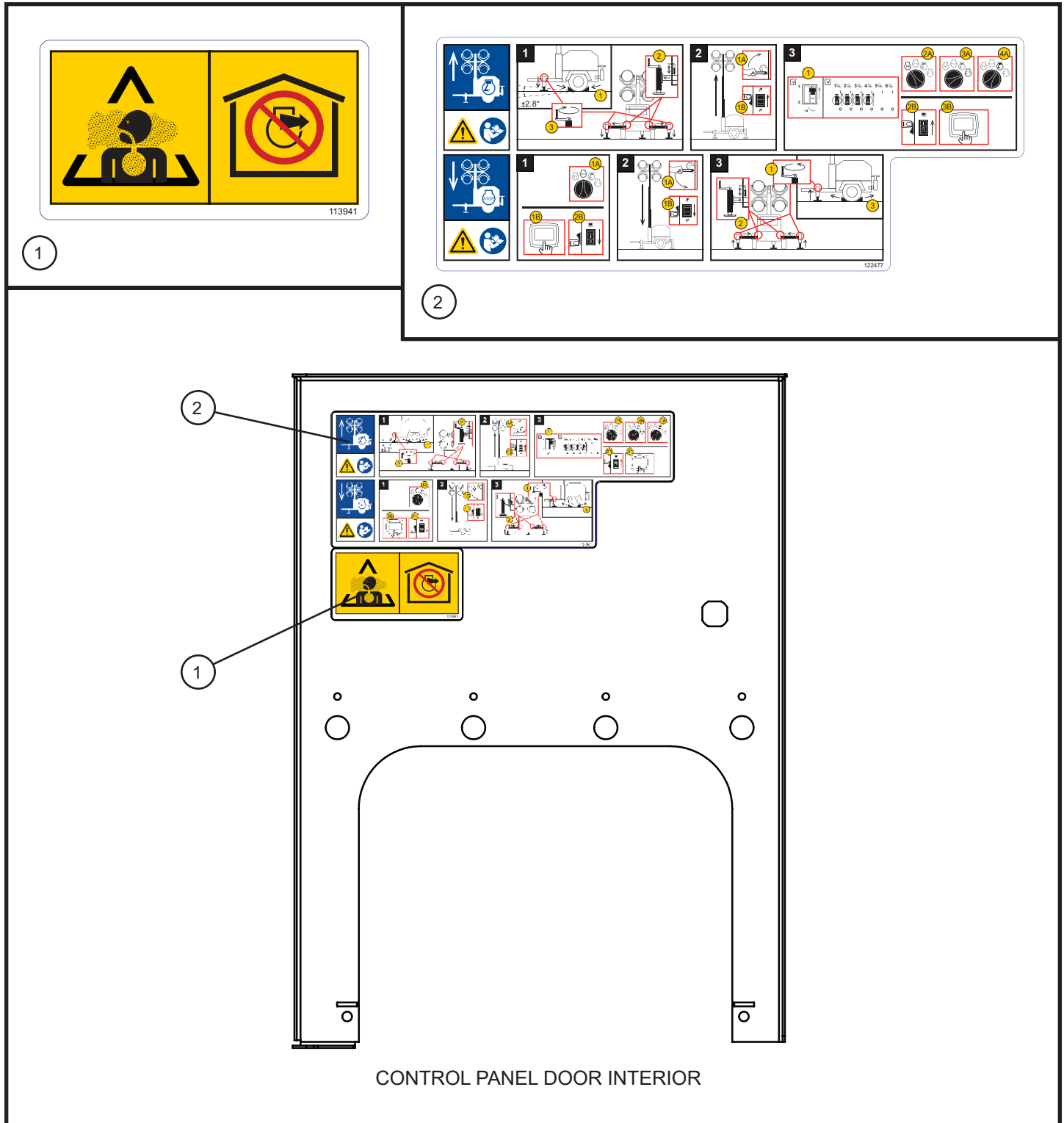

15.3 - International Wordless Safety Decals (6 of 6)

Item	Part No.	Part Description	Qty.
1	113941	DECAL EXHAUST WARNING WORDLESS	1
2	122477	START INSTRUCTIONS DECAL	1

15.4 - Electrical Decals (1 of 4)

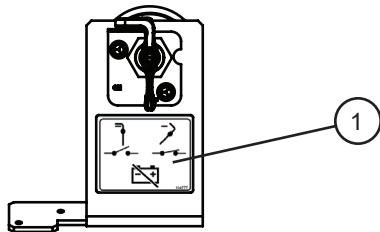

BATTERY DISCONNECT
DETAIL

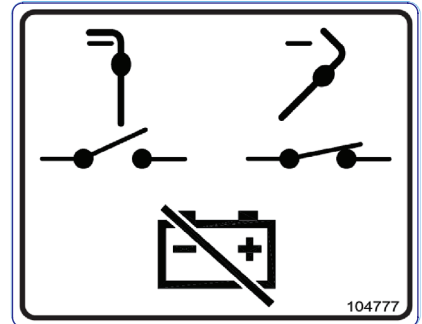

1

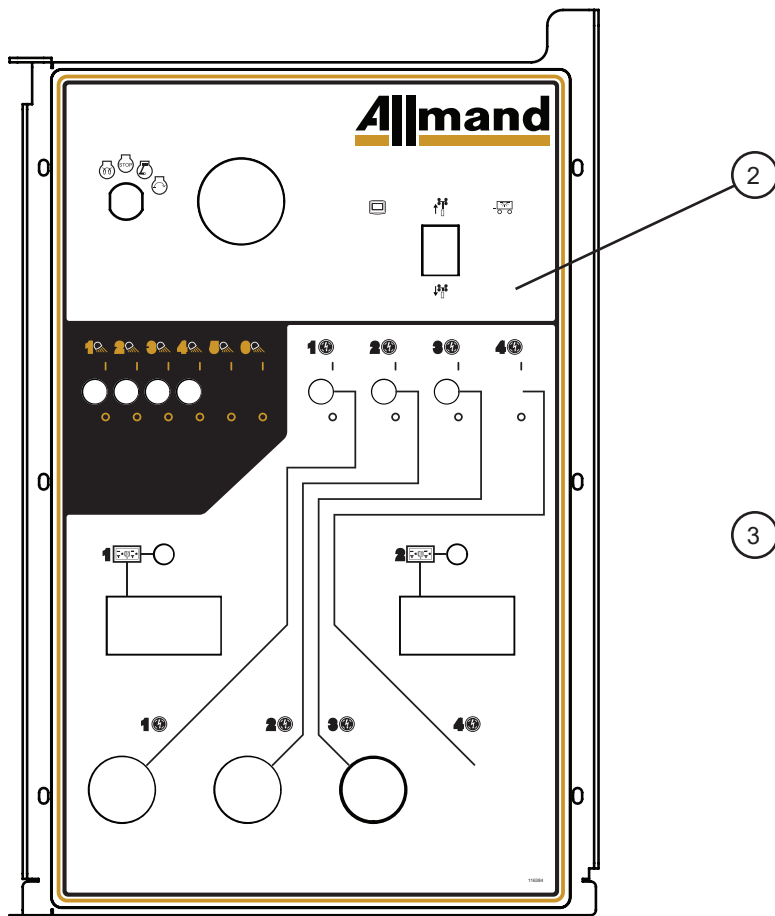

CONTROL PANEL
DETAIL



3

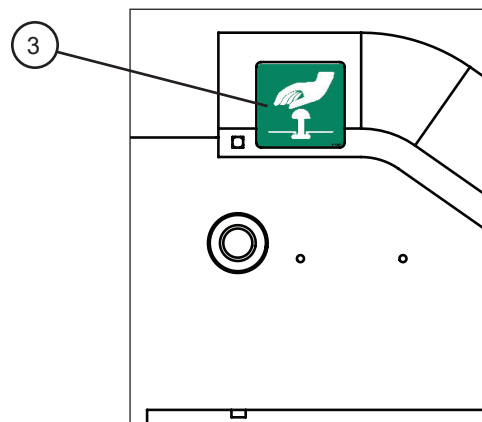

EMERGENCY STOP
DETAIL

15.4 - Electrical Decals (1 of 4)

Item	Part No.	Part Description	Qty.
1	104777	BATTERY DISCONNECT DECAL	1
2	116384	MAXI-LITE OUTLET PANEL DECAL	1
	116703	MAXI-LITE OUTLET PANEL DECAL	1
3	105567	EMERGENCY STOP DECAL	1

15.4 - Electrical Decals (2 of 4)

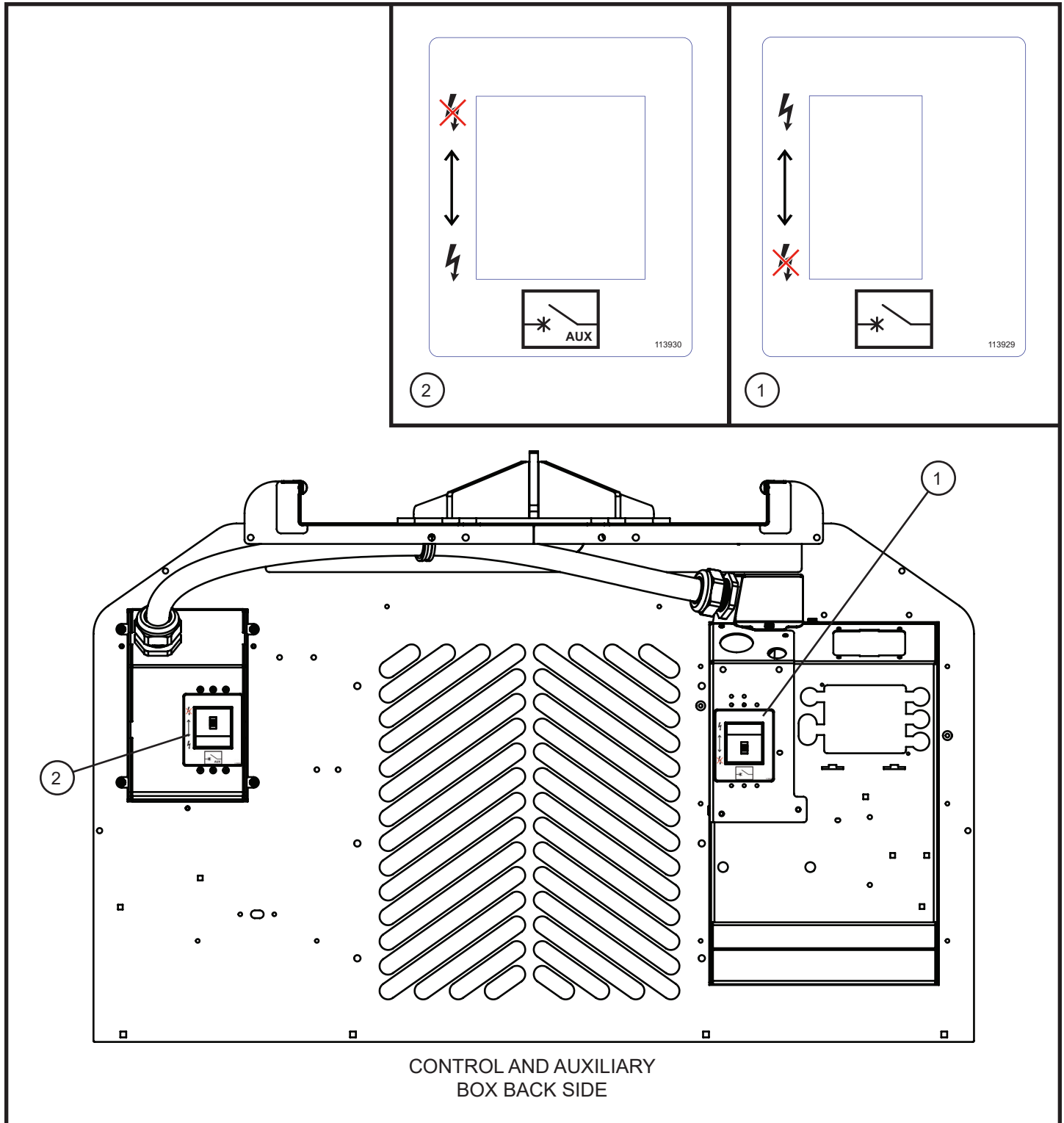

15.4 - Electrical Decals (2 of 4)

Item	Part No.	Part Description	Qty.
1	113929	MAXI-LITE MAIN BREAKER DECAL	1
2	113930	MAXI-LITE AUX BREAKER DECAL	1

15.4 - Electrical Decals (3 of 4)

<div style="border: 1px solid black; padding: 5px;"> <p style="text-align: center;">NOTICE</p> <p>Route power cables under panel door to power distribution terminals and single phase outlets.</p> <p style="text-align: center;">AVIS</p> <p>Acheminer les câbles d'alimentation sous la porte à panneau jusqu'aux bornes de distribution de courant et aux prises monophasées.</p> <p style="text-align: center;">↓ ↓</p> <p style="text-align: right; font-size: small;">122081</p> </div> <p style="text-align: center; font-size: 24px; border: 1px solid black; border-radius: 50%; width: 30px; margin: 10px auto;">3</p>	<div style="border: 1px solid black; padding: 5px;"> <p style="text-align: right; font-size: small;">123961</p> </div> <p style="text-align: center; font-size: 24px; border: 1px solid black; border-radius: 50%; width: 30px; margin: 10px auto;">1</p>	<div style="border: 1px solid black; padding: 5px;"> <p style="text-align: center; background-color: red; color: white; font-weight: bold;">⚠ DANGER</p> <div style="text-align: center;"> </div> <p style="text-align: center; background-color: red; color: white; font-weight: bold;">⚠ DANGER</p> <p style="text-align: right; font-size: small;">118074</p> </div> <p style="text-align: center; font-size: 24px; border: 1px solid black; border-radius: 50%; width: 30px; margin: 10px auto;">2</p>
<div style="display: flex; justify-content: space-between;"> <div style="width: 45%;"> <p style="text-align: center;">POWER LUGS DOOR EXTERIOR</p> </div> <div style="width: 45%;"> <p style="text-align: center;">POWER LUGS BOX BACKSIDE</p> </div> </div> <div style="margin-top: 20px;"> <p style="text-align: center;">POWER LUGS DOOR INTERIOR</p> </div>		

15.4 - Electrical Decals (3 of 4)

Item	Part No.	Part Description	Qty.
1	123961	DECAL ELECTRIC WIRING INFO MAXI-POWER SINGLE PHASE	1
2	118074	DECAL BILINGUAL DANGER HAZARDOUS VOLTAGE VERTICAL	2
3	122081	DECAL TERMINAL CONNECTIONS NOTICE MAXI-POWER	1

15.4 - Electrical Decals (4 of 4)

<div data-bbox="133 478 402 835"> <table border="1"> <tr><td>8 kW</td></tr> <tr><td>60 Hz</td></tr> <tr><td>120/240 V</td></tr> <tr><td>67/33 A</td></tr> <tr><td>1 Ø</td></tr> </table> <p>112127</p> </div> <div data-bbox="116 856 165 907">1</div>	8 kW	60 Hz	120/240 V	67/33 A	1 Ø	<div data-bbox="483 478 753 835"> <table border="1"> <tr><td>15 kW</td></tr> <tr><td>60 Hz</td></tr> <tr><td>120/240 V</td></tr> <tr><td>125/63 A</td></tr> <tr><td>1 Ø</td></tr> </table> <p>112130</p> </div> <div data-bbox="467 856 516 907">2</div>	15 kW	60 Hz	120/240 V	125/63 A	1 Ø	<div data-bbox="841 478 1110 835"> <table border="1"> <tr><td>20 kW</td></tr> <tr><td>60 Hz</td></tr> <tr><td>120/240 V</td></tr> <tr><td>167/83 A</td></tr> <tr><td>1 Ø</td></tr> </table> <p>112132</p> </div> <div data-bbox="824 856 873 907">3</div>	20 kW	60 Hz	120/240 V	167/83 A	1 Ø	<div data-bbox="1209 478 1479 835"> <table border="1"> <tr><td>20 kW</td></tr> <tr><td>60 Hz</td></tr> <tr><td>120/208 V</td></tr> <tr><td>56 A</td></tr> <tr><td>3 Ø</td></tr> </table> <p>112133</p> </div> <div data-bbox="1193 856 1242 907">4</div>	20 kW	60 Hz	120/208 V	56 A	3 Ø
8 kW																							
60 Hz																							
120/240 V																							
67/33 A																							
1 Ø																							
15 kW																							
60 Hz																							
120/240 V																							
125/63 A																							
1 Ø																							
20 kW																							
60 Hz																							
120/240 V																							
167/83 A																							
1 Ø																							
20 kW																							
60 Hz																							
120/208 V																							
56 A																							
3 Ø																							

CONTROL PANEL
DOOR DETAIL

114170_A
114172_A
114174_A
114175_A

15.4 - Electrical Decals (4 of 4)

Item	Part No.	Part Description	Qty.
1	112127	DECAL ELECTRICAL INFO 8kW 60Hz 1 PHASE	1
2	112130	DECAL ELECTRICAL INFO 15kW 60Hz 1 PHASE	1
3	112132	DECAL ELECTRICAL INFO 20kW 60Hz 1 PHASE	1
4	112133	DECAL ELECTRICAL INFO 20kW 60Hz 3 PHASE	1

15.5 - Conspicuity Tape

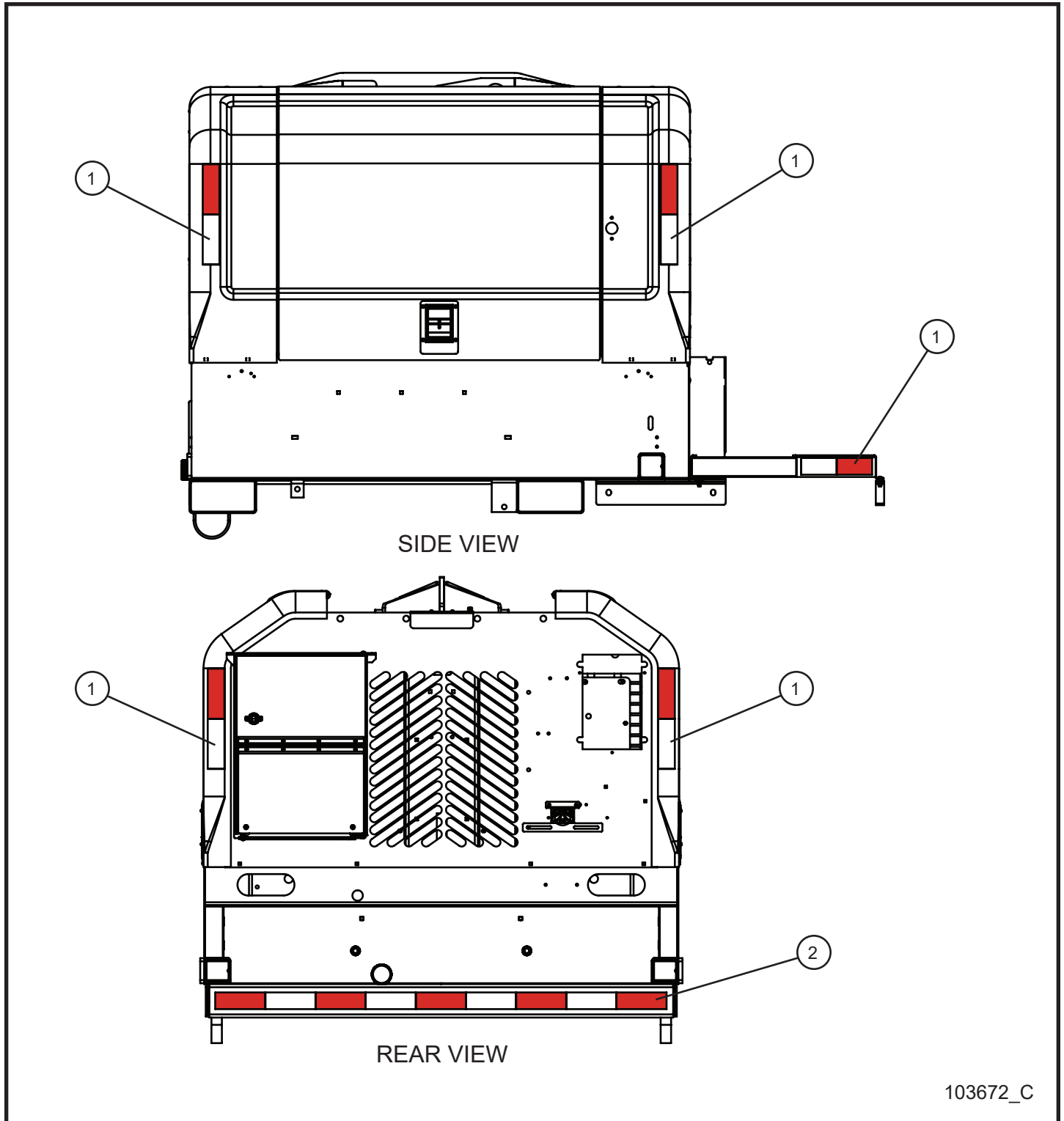

15.5 - Conspicuity Tape

Item	Part No.	Part Description	Qty.
1	654004	CONSPICUITY TAPE x 12.0	10
2	654004	CONSPICUITY TAPE x 54.0	1

Maxi-Lite®

Allmand®

**1502 West 4th Avenue
Holdrege, NE 68949**

phone: (308) 995-4495 • toll free: (800) 562-1373

fax: (308) 995-5887

www.allmand.com