

Allmand™

Brighter. Warmer. Safer.



(en) **Parts & Wire Schematic Manual**
PORT-A-LITE®
PAL2000 & PAL2500

Not for Reproduction

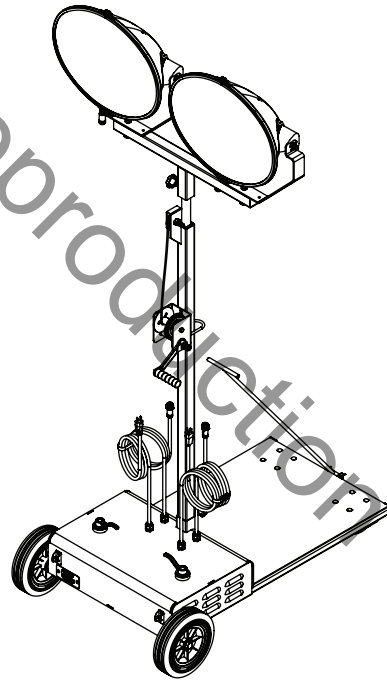

Copyright © 2016 Allmand Bros., Inc.
Holdrege, NE, USA. All rights reserved.

Part No.: 109002
Revision: A

**Portable
Industrial
Heaters**

**Portable
Light Towers**

**Portable
Light Stands**

**Solar Flashing
Arrow Boards**

LIGHT TOWER APP



Reliability, Performance, and Integrity Since 1938

www.allmand.com

TABLE OF CONTENTS

1.0 BASE AND MAST ASSEMBLY GROUP

PAL 2000 Base Assembly Group	(1.1)
PAL 2500 Base Assembly Group	(1.2)
PAL Outer Mast Assembly Group	(1.3)
PAL Inner Mast Assembly Group	(1.4)

2.0 LAMP ASSEMBLY

1000W Lamp Assembly Group	(2.1)
1250W Lamp Assembly Group	(2.2)
Lampholder Assembly Group	(2.3)

3.0 DECALS

PAL 2000 Decal Group	(3.1)
PAL 2500 Decal Group	(3.2)

4.0 WIRING SCHEMATICS

PAL 2000 50Hz Base Schematic	(4.1)
PAL 2500 60Hz Base Schematic	(4.2)

PAL2000 & PAL2500

Not for Reproduction

PAGE LEFT BLANK
INTENTIONALLY

1.1 - PAL 2000 Base Assembly Group (1 of 3)

SN 16-000001 and UP

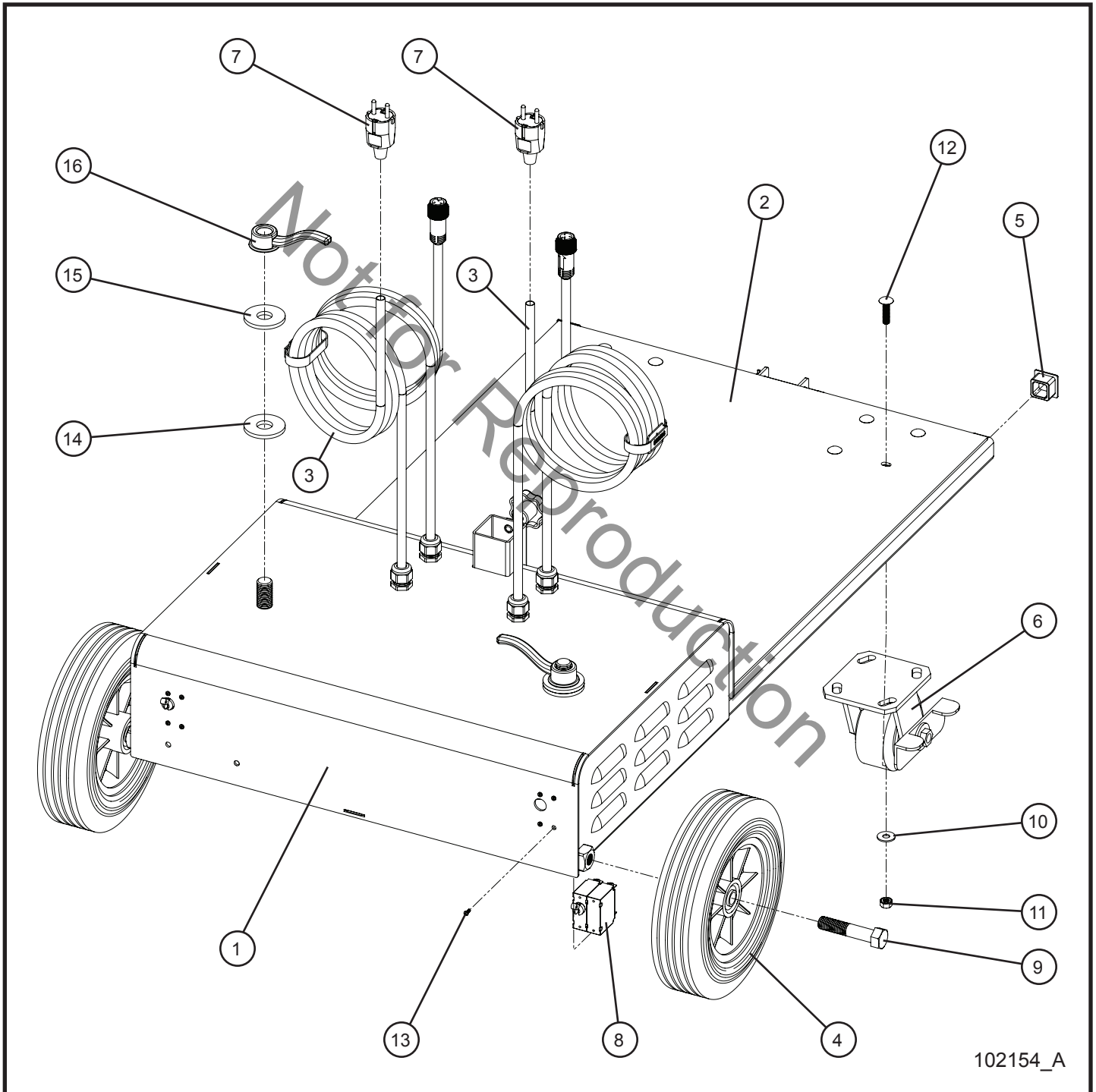

102154_A

PAL2000 & PAL2500

1.1 - PAL 2000 Base Assembly Group (1 of 3)

SN 16-000001 and UP

Item	Part No.	Part Description	Qty.
1	102375P	BASE WELDMENT PAL2000	1
	108977P	BASE WELDMENT PAL2000 1/2-13 LOCK KNOB	1
2	530506P	GENERATOR PLATE	1
3	530126	PRIMARY 16/3 CORD	2
4	530128	10" x 1 3/4 WHEEL	2
5	530137	END CAP	2
6	530336	CASTER W/ BRAKES	2
7	108840	PLUG SCHUKO 50Hz	2
8	650530	15 AMP DPST BREAKER SWITCH	2
9	046244	5/8-11 x 3 HEX HEAD CS GR5 PL	2
10	047010	5/16 FLAT WASHER PL	8
11	044031	5/16-18 KEPS HEX NUT PL	8
12	053022	5/16-18 x 1 1/4 CARRIAGE BOLT PL	8
13	041251	M3 x 0.5mm x 8mm PH-PAN HEAD MS ZC	8
14	650550	.785" x 2" HDPE WASHER	2
15	047035	3/4 FLAT WASHER PL	2
16	630728	SHO HANDLE NUT	2
17	108795	SCHEMATIC PAL2000 50Hz BASE	1

1.1 - PAL 2000 Base Assembly Group (2 of 3)

SN 16-00001 and UP

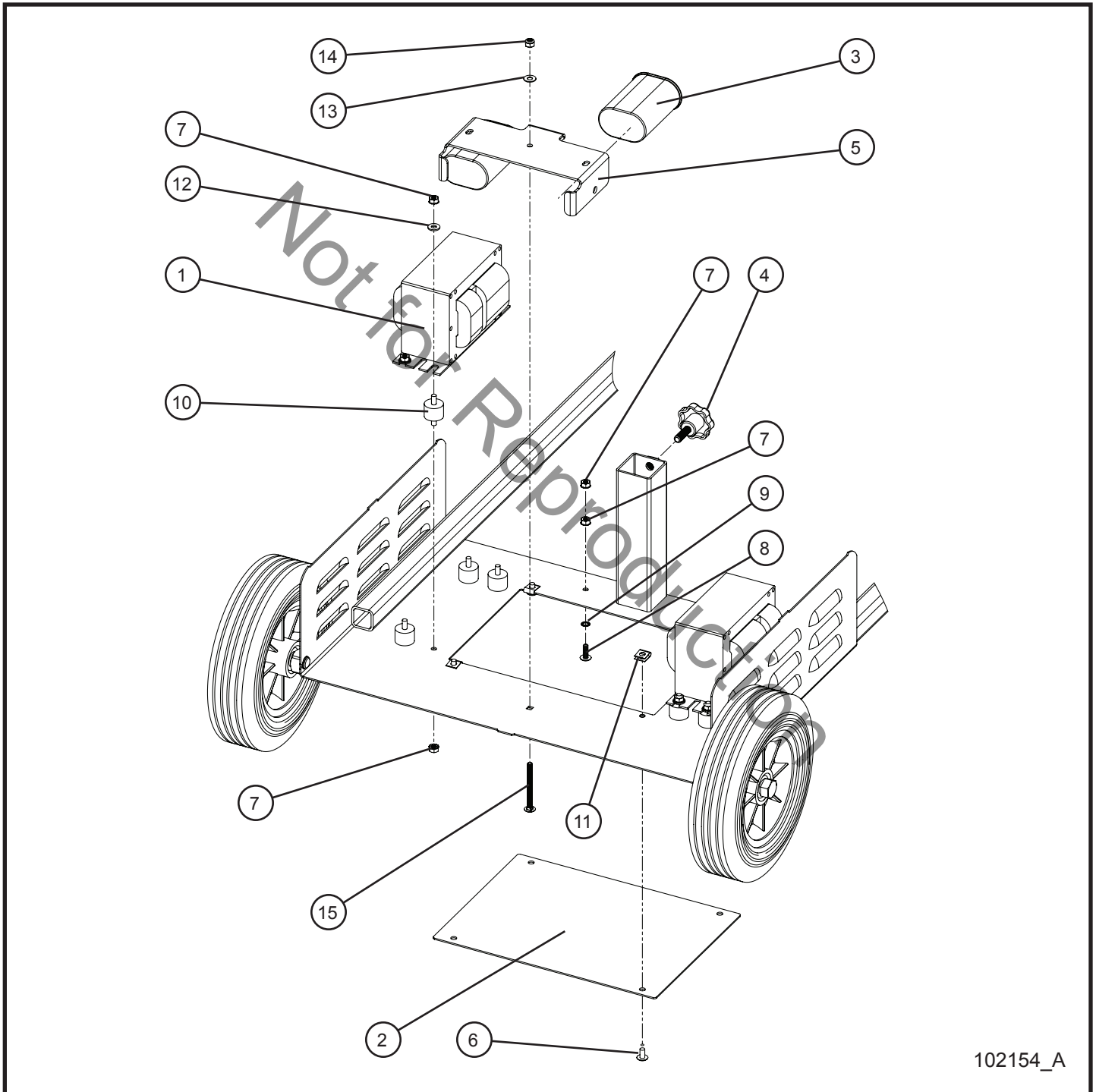

102154_A

PAL2000 & PAL2500

1.1 - PAL 2000 Base Assembly Group (2 of 3)

SN 16-000001 and UP

Item	Part No.	Part Description	Qty.
1	310116A	BALLAST KIT 1000W 50Hz (INCLUDES 310115A)	2
2	530508P	COVER BOTTOM PAL 2500	1
3	310115A	CAPACITOR 26uF 60/50Hz 540V	2
4	100516	LOCKING KNOB	1
	620550	1/2-13 LOCKING KNOB	1
5	100392P	TABBED CAPACITOR CLAMP	1
6	041078	1/4-20 x 1/2 PH-TRUSS HEAD MS SS	4
7	044021	1/4-20 KEPS HEX NUT PL	18
8	041050	1/4-20 x 3/4 PH-TRUSS HEAD MS SS	1
9	043050	1/4 INTL TOOTH LOCK WASHER	1
10	330057	BOX MOUNT RUBBER	8
11	045216	1/4-20 TINNERMAN NUT	4
12	047005	1/4 FLAT WASHER PL	8
13	047009	1/4 FLAT WASHER SAE SS	1
14	044023	1/4-20 NYLOCK HEX NUT PL	1
15	100718	1/4-20 x 2 1/4 CARRIAGE BOLT	1

1.1 - PAL 2000 Base Assembly Group (3 of 3)

SN 16-000001 and UP

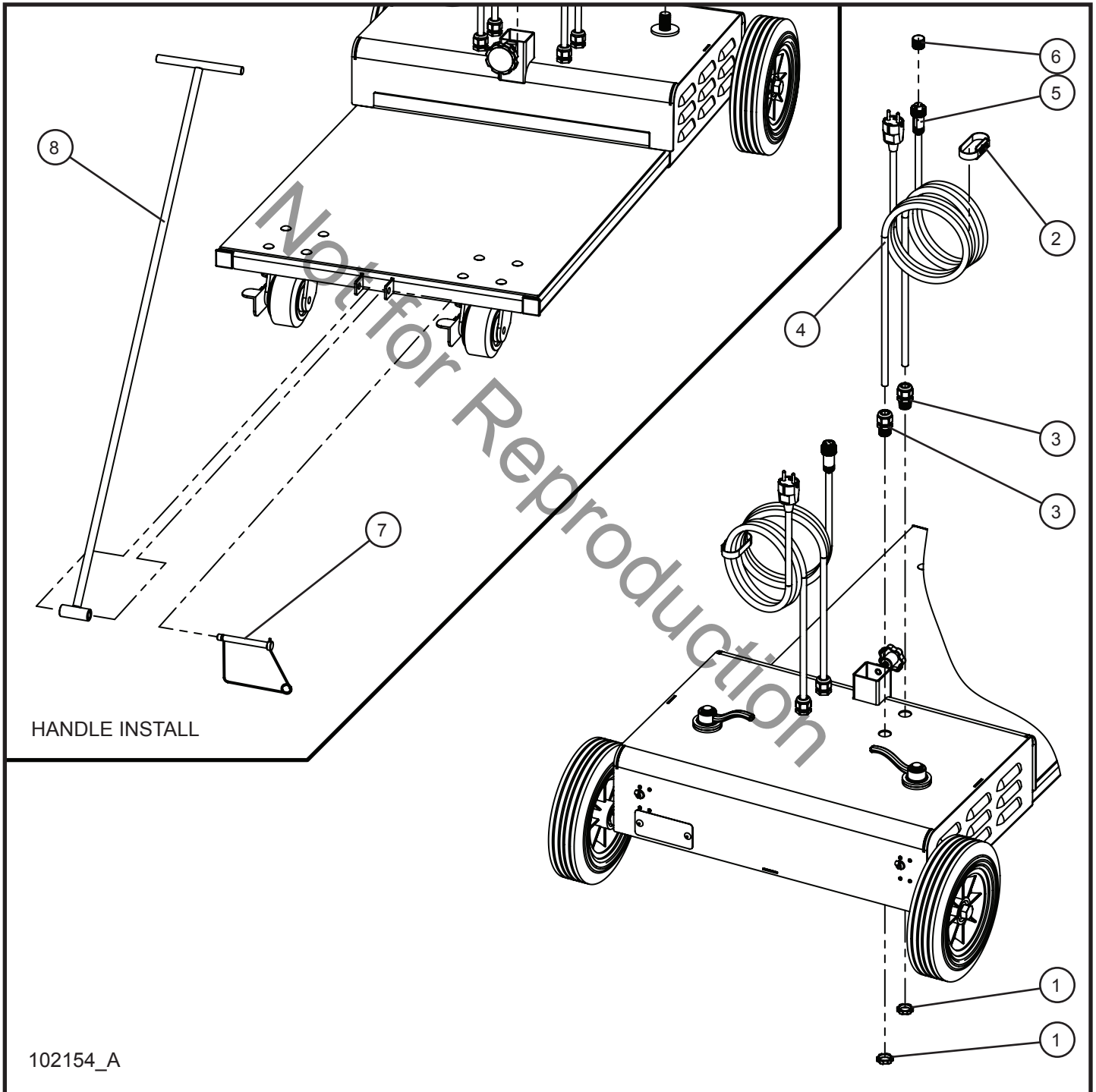

102154_A

PAL2000 & PAL2500

1.1 - PAL 2000 Base Assembly Group (3 of 3)

SN 16-000001 and UP

Item	Part No.	Part Description	Qty.
1	022035	1/2 CORD GRIP NUT	4
2	068098	VELCRO TIE CABLE	2
3	105626	CORD GRIP 1/2" NYLON BLACK	4
4	530126	PRIMARY 16/3 CORD	2
5	530127	FEMALE CONNECTOR CABLE MINI QUICK	2
6	530136	ALUMINUM COUPLER	2
7	712017	LOCK PIN SNAP	1
8	530522	T-HANDLE WELDMENT	1

For Reproduction

1.2 - PAL 2500 Base Assembly Group (1 of 3)

SN 04-000001 and UP

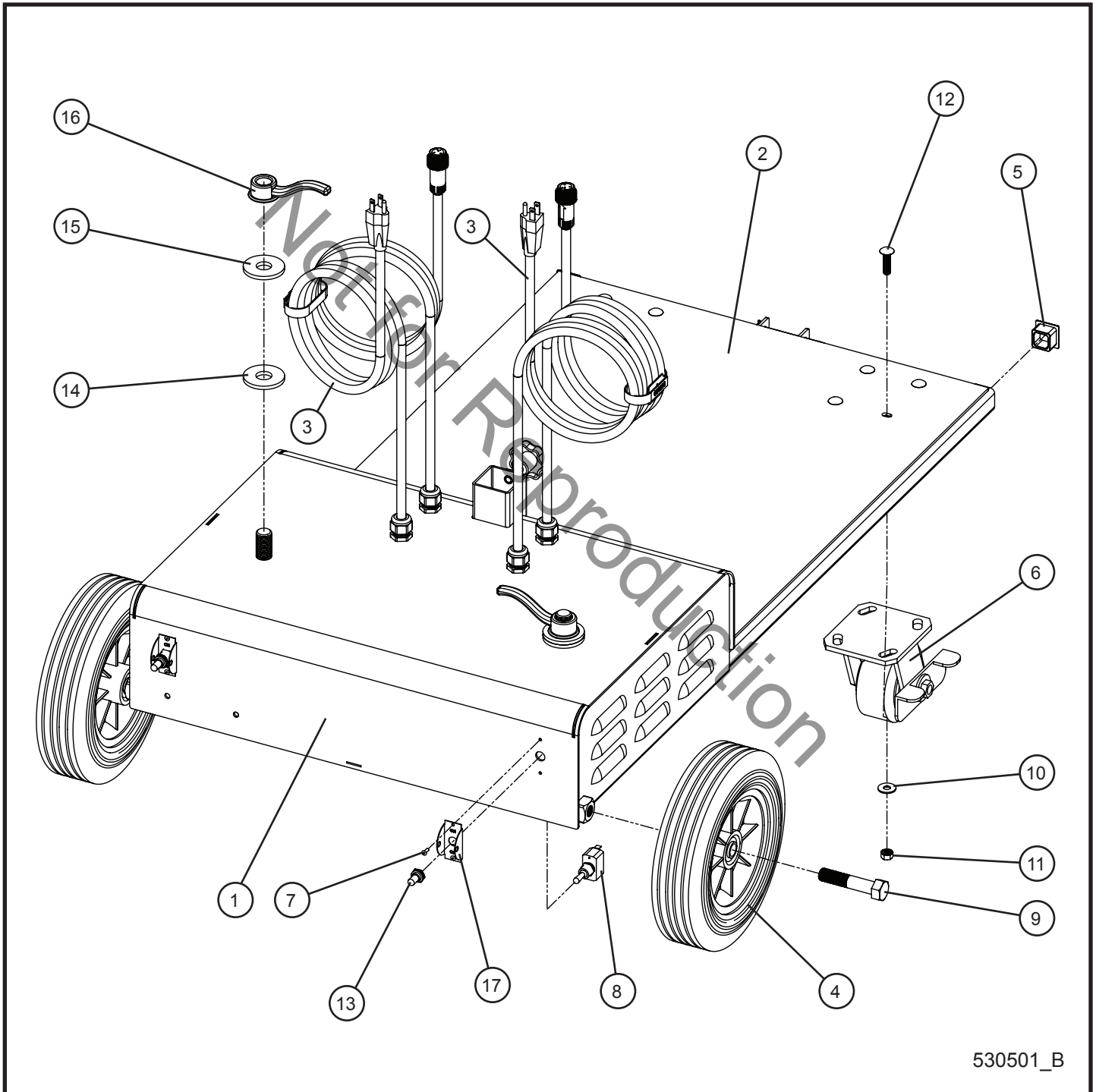

PAL2000 & PAL2500

1.2 - PAL 2500 Base Assembly Group (1 of 3)

SN 04-000001 and UP

Item	Part No.	Part Description	Qty.
1	530507P	BASE WELDMENT PAL2500	1
	108978P	BASE WELDMENT PAL2500 1/2-13 LOCK KNOB	1
2	530506P	GENERATOR PLATE	1
3	530126	PRIMARY 16/3 CORD	2
4	530128	10" x 1 3/4 WHEEL	2
5	530137	END CAP	2
6	530336	CASTER W/ BRAKES	2
7	045116	1/8 x 1/4 BLIND RIVET	4
8	530123	20A SPST TOGGLE SWITCH	2
9	046244	5/8-11 x 3 HEX HEAD CS GR5 PL	2
10	047010	5/16 FLAT WASHER PL	8
11	044031	5/16-18 KEPS HEX NUT PL	8
12	053022	5/16-18 x 1 1/4 CARRIAGE BOLT PL	8
13	530124	BOOT SWITCH COVER	2
14	650550	.785" x 2" HDPE WASHER	2
15	047035	3/4 FLAT WASHER PL	2
16	630728	SHO HANDLE NUT	2
17	530125	SWITCH GUARD	2
18	108793	SCHEMATIC PAL2500 60Hz BASE	1

1.2 - PAL 2500 Base Assembly Group (2 of 3)

SN 04-000001 and UP

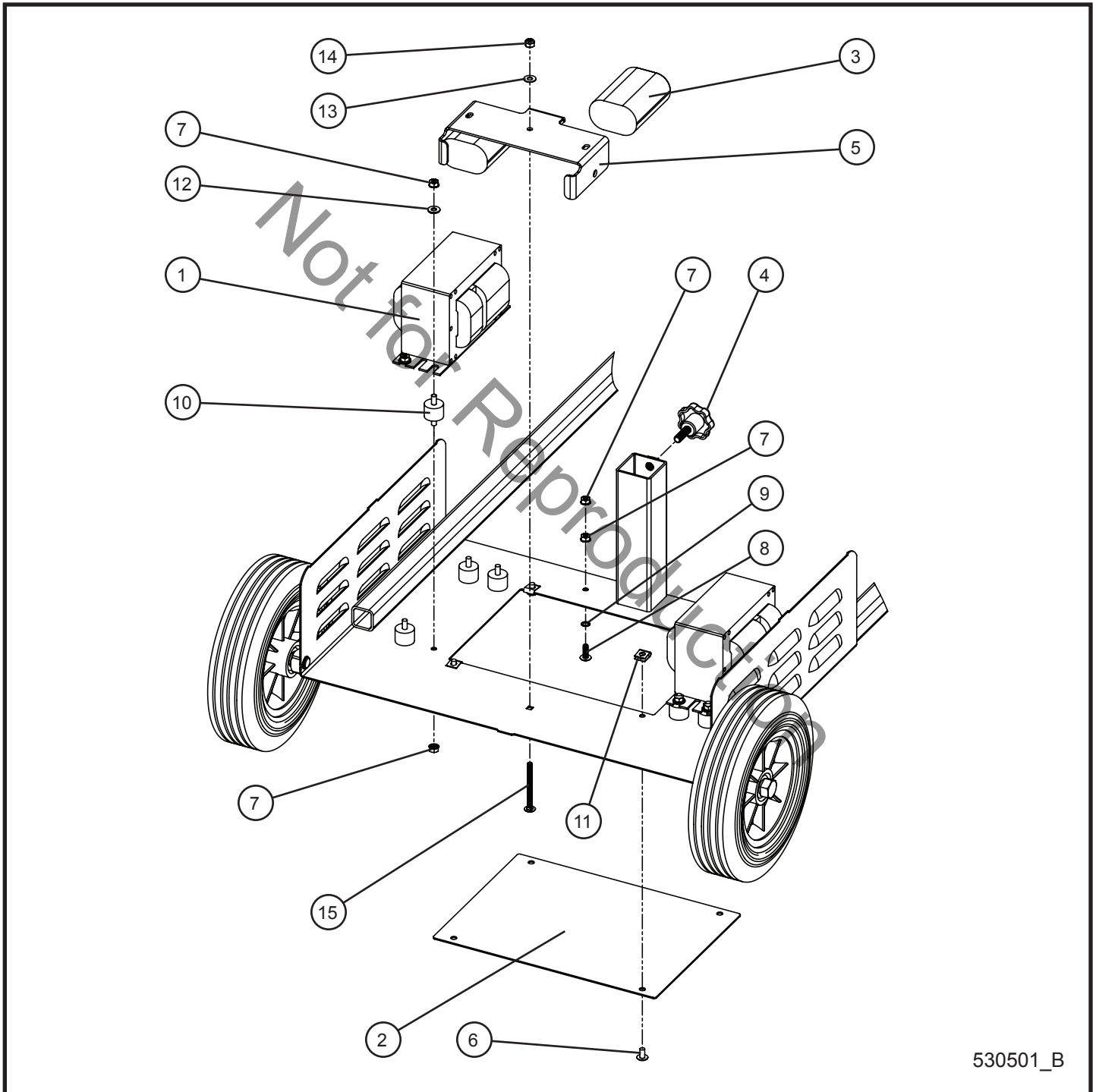

530501_B

PAL2000 & PAL2500

1.2 - PAL 2500 Base Assembly Group (2 of 3)

SN 04-000001 and UP

Item	Part No.	Part Description	Qty.
1	310124	TRANSFORMER 60Hz 110-480 VOLTS	2
2	530508P	COVER BOTTOM PAL 2500	1
3	310391	CAPACITOR 28uF	2
4	100516	LOCKING KNOB	1
	620550	1/2-13 LOCKING KNOB	1
5	100392P	TABBED CAPACITOR CLAMP	1
6	041078	1/4-20 x 1/2 PH-TRUSS HEAD MS SS	4
7	044021	1/4-20 KEPS HEX NUT PL	18
8	041050	1/4-20 x 3/4 PH-TRUSS HEAD MS SS	1
9	043050	1/4 INTL TOOTH LOCK WASHER	1
10	330057	BOX MOUNT RUBBER	8
11	045216	1/4-20 TINNERMAN NUT	4
12	047005	1/4 FLAT WASHER PL	8
13	047009	1/4 FLAT WASHER SAE SS	1
14	044023	1/4-20 NYLOCK HEX NUT PL	1
15	100718	1/4-20 x 2 1/4 CARRIAGE BOLT	1

1.2 - PAL 2500 Base Assembly Group (3 of 3)

SN 04-000001 and UP

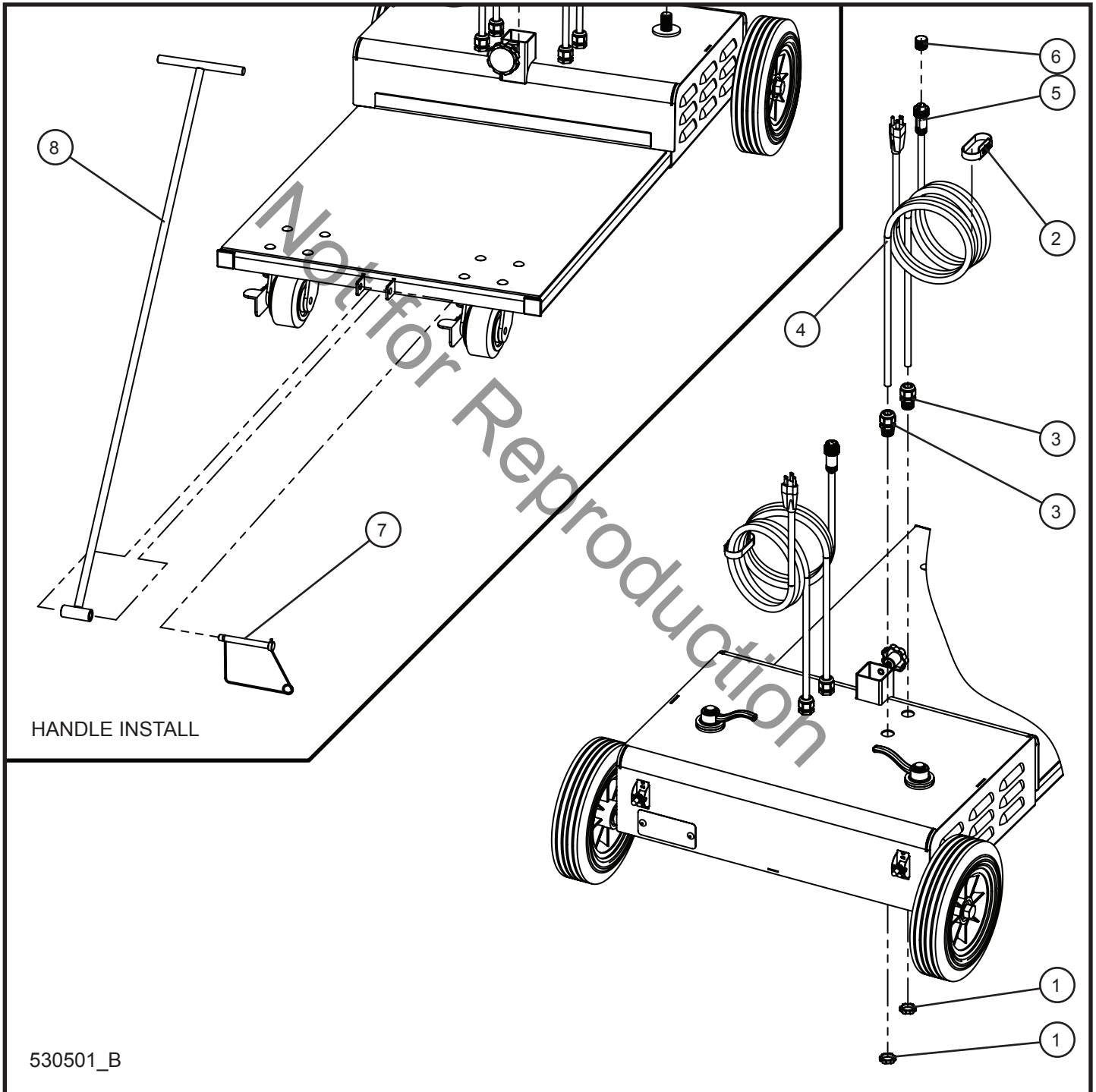

530501_B

PAL2000 & PAL2500

1.2 - PAL 2500 Base Assembly Group (3 of 3)

SN 04-000001 and UP

Item	Part No.	Part Description	Qty.
1	022035	1/2 CORD GRIP NUT	4
2	068098	VELCRO TIE CABLE	2
3	105626	CORD GRIP 1/2" NYLON BLACK	4
4	530126	PRIMARY 16/3 CORD	2
5	530127	FEMALE CONNECTOR CABLE MINI QUICK	2
6	530136	ALUMINUM COUPLER	2
7	712017	LOCK PIN SNAP	1
8	530522	T-HANDLE WELDMENT	1

For Reproduction

1.3 - PAL Outer Mast Assembly Group

SN 16-000001 and UP
SN 04-000001 and UP

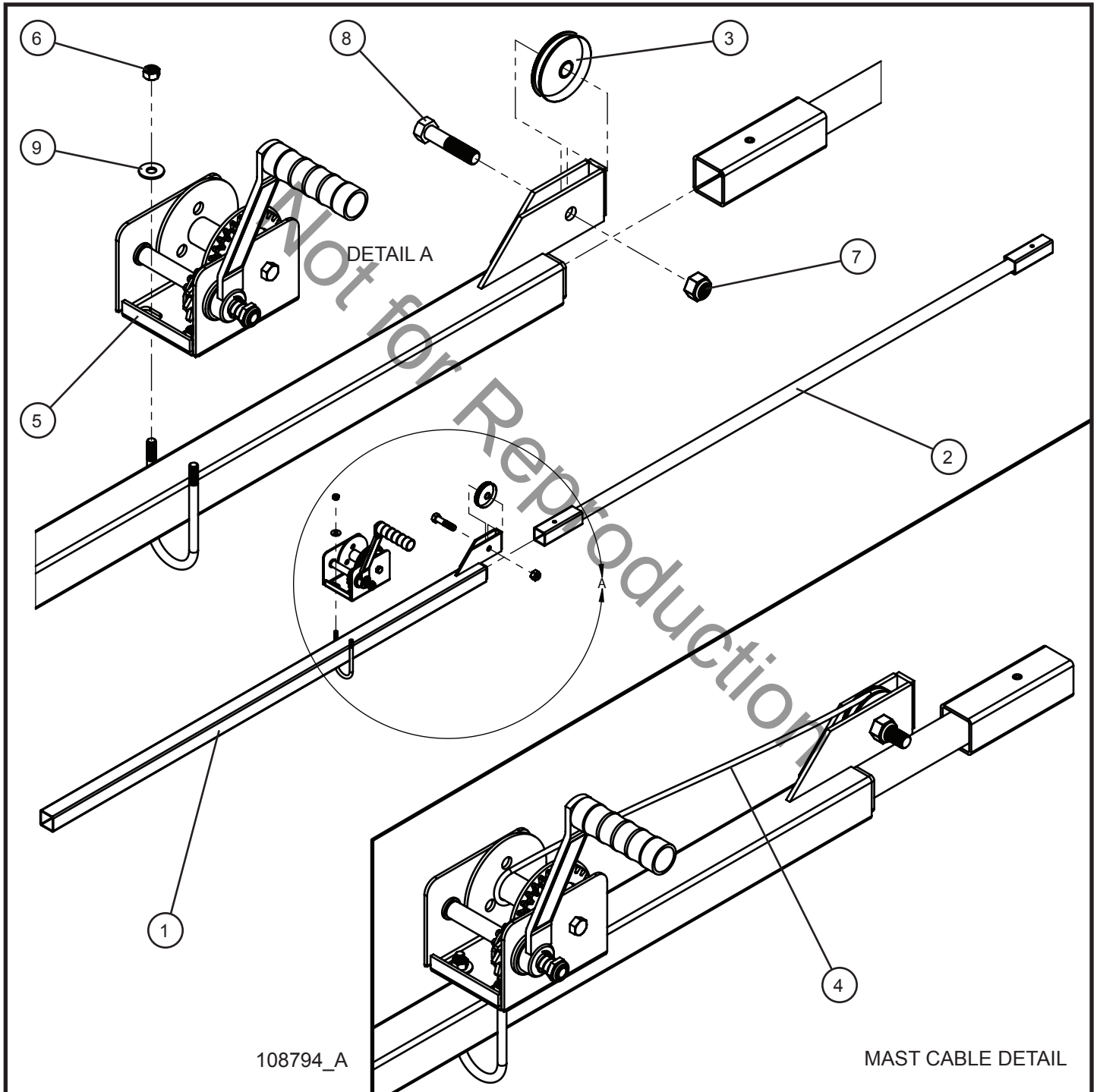

PAL2000 & PAL2500

1.3 - PAL Outer Mast Assembly Group

SN 16-000001 and UP
SN 04-000001 and UP

Item	Part No.	Part Description	Qty.
1	530513P	OUTER MAST WELDMENT	1
2	530509	INNER MAST ASSEMBLY	1
3	320112	2-1/2 PULLEY W/ BUSHING	1
4	320185	CABLE 3/16 STEEL 10'	1
5	530337	WINCH DLB 350	1
6	044033	5/16-18 NYLOCK HEX NUT PL	2
7	044048	1/2-13 NYLOCK HEX NUT PL	1
8	046200	1/2-13 x 2 1/4 HEX HEAD CS GR5 PL	1
9	047010	5/16 FLAT WASHER PL	2

1.4 - PAL Inner Mast Assembly Group

SN 16-000001 and UP
SN 04-000001 and UP

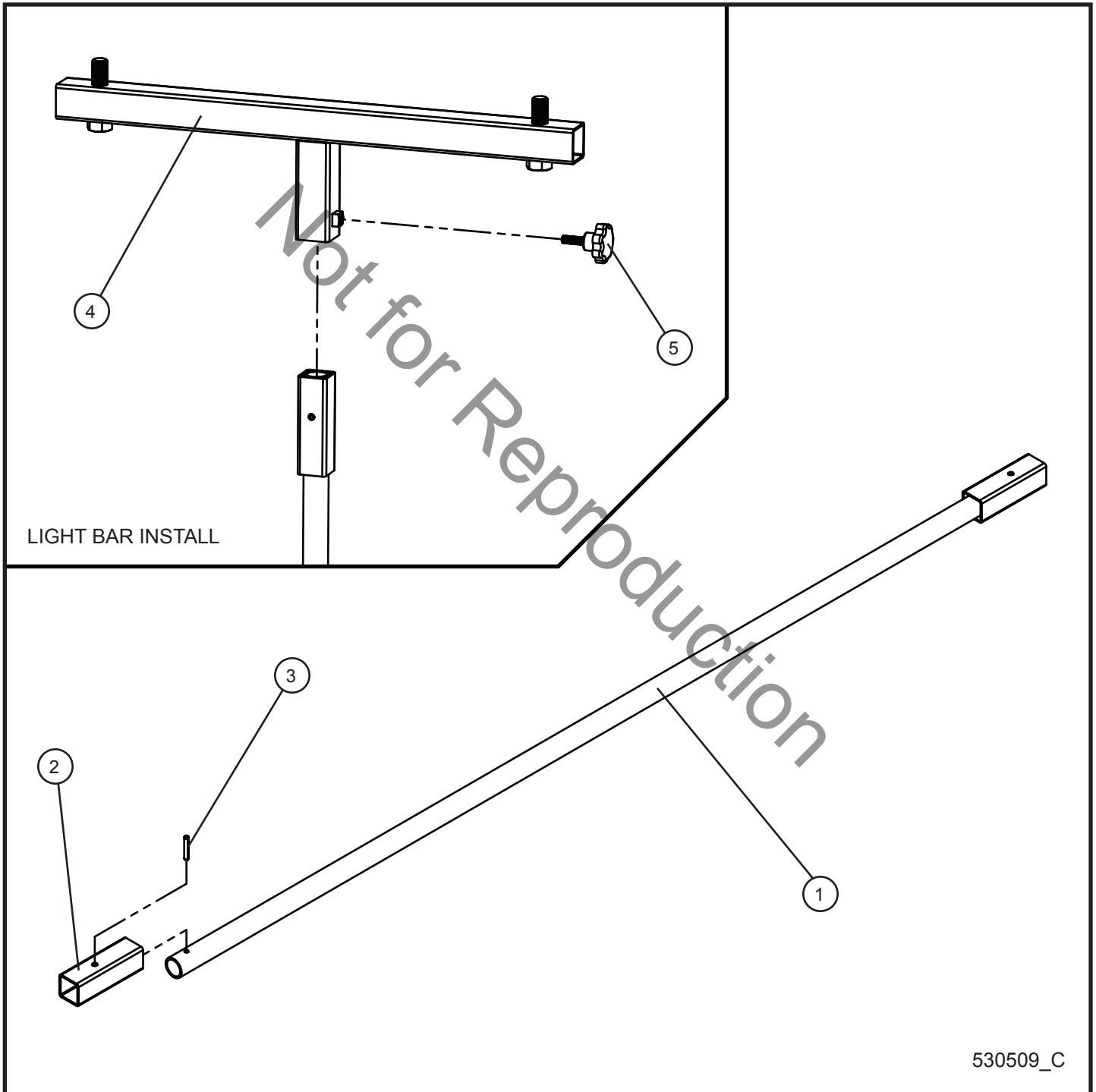

PAL2000 & PAL2500

1.4 - PAL Inner Mast Assembly Group

SN 16-000001 and UP
SN 04-000001 and UP

Item	Part No.	Part Description	Qty.
1	530510P	MAST TUBE INNER	1
2	530511P	GUIDE TUBE INNER MAST	2
3	045145	1/4 x 1 1/2 SPRING ROLL PIN PL	2
4	530430P	LIGHT BAR WELDMENT PAL	1
	108980P	1/2-13 LOCKING KNOB LIGHT BAR WELDMENT PAL	1
5	100516	LOCKING KNOB	1
	620550	1/2-13 LOCKING KNOB	1

Not for Reproduction

2.1 - 1000W Lamp Assembly Group

SN 16-000001 and UP

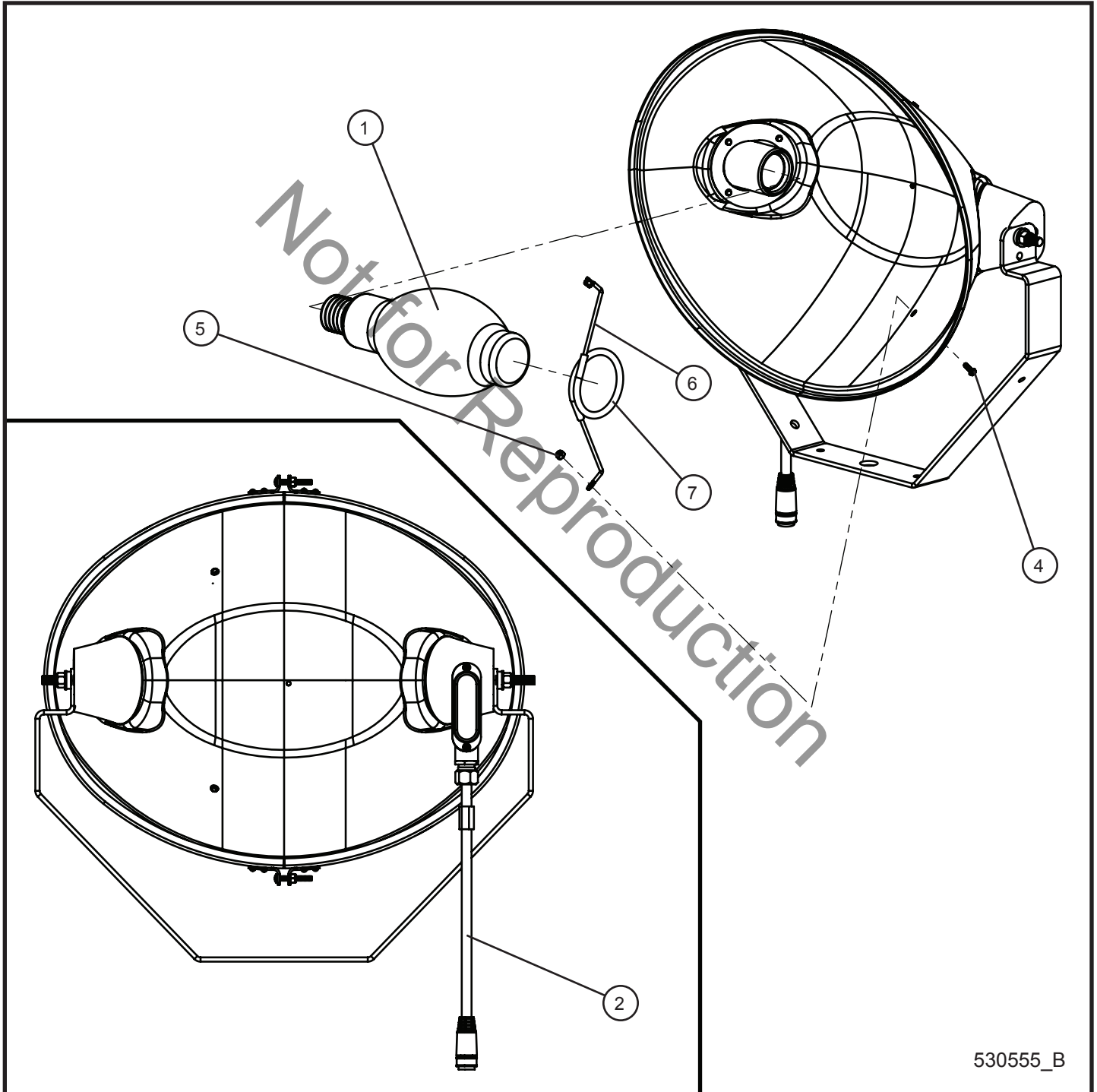

530555_B

PAL2000 & PAL2500

2.1 - 1000W Lamp Assembly Group

SN 16-000001 and UP

Item	Part No.	Part Description	Qty.
--	530555	1000W LAMP COMPLETE ASSEMBLY	1
1	610211	LAMP 1000W BT37 (MH)	1
2	310434	MALE CONNECTOR CABLE MINI QUICK	1
3	102624	2 WIRE LEVER LOCK (NOT SHOWN)	3
4	041200	#8-32 x 1/2 HEX WASHER HEAD INDT	2
5	044013	#8-32 NYLOCK HEX NUT SS	2
6	610209	SUPPORT TIP LAMP SHO	1
7	610210	FIBERGLASS TUBE 12" LAMP SUPPORT	1

For Reproduction

2.2 - 1250W Lamp Assembly Group

SN 04-000001 and UP

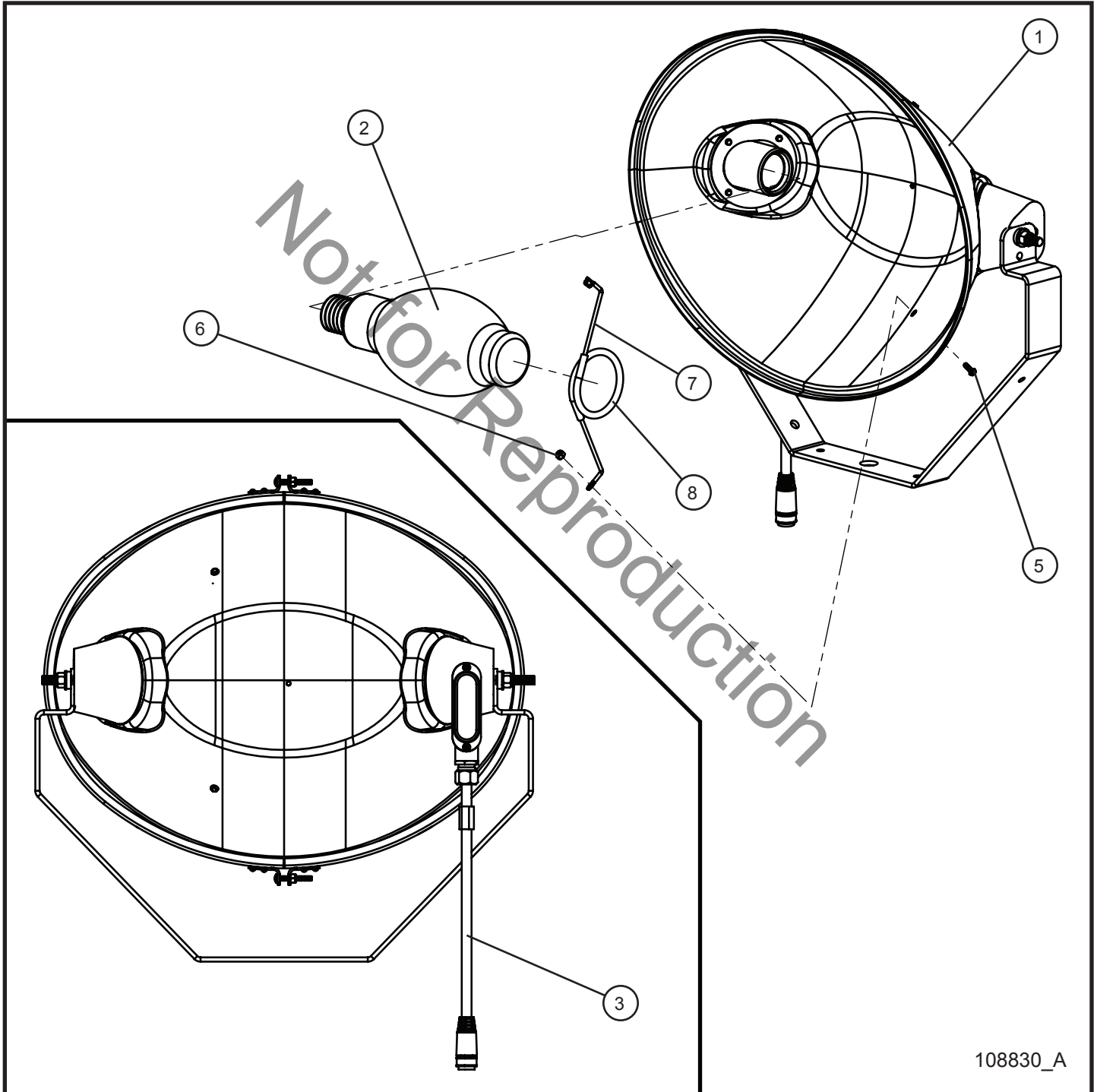

108830_A

PAL2000 & PAL2500

2.2 - 1250W Lamp Assembly Group

SN 04-000001 and UP

Item	Part No.	Part Description	Qty.
--	108830	1250W LAMP COMPLETE ASSEMBLY	1
1	650147	LAMPHOLDER SHO ASSEMBLED	1
2	610221	LAMP 1250W BT37 (MH)	1
3	310434	MALE CONNECTOR CABLE MINI QUICK	1
4	102624	2 WIRE LEVER LOCK (NOT SHOWN)	3
5	041200	#8-32 x 1/2 HEX WASHER HEAD INDT	2
6	044013	#8-32 NYLOCK HEX NUT SS	2
7	610209	SUPPORT TIP LAMP SHO	1
8	610210	FIBERGLASS TUBE 12" LAMP SUPPORT	1

2.3 - Lampholder Assembly Group

SN 16-000001 and UP
SN 04-000001 and UP

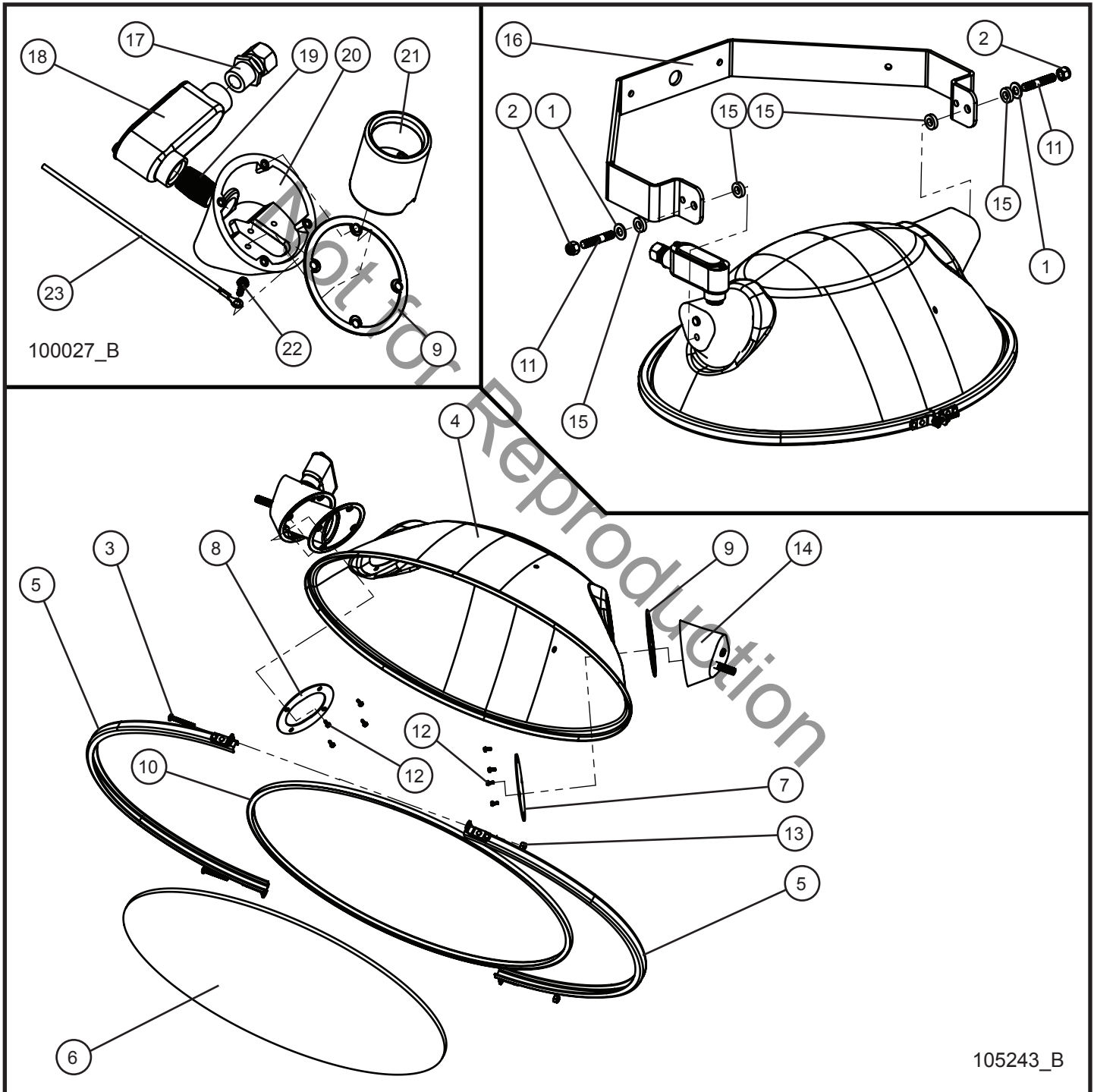

PAL2000 & PAL2500

2.3 - Lampholder Assembly Group

SN 16-000001 and UP
SN 04-000001 and UP

Item	Part No.	Part Description	Qty.
1	047016	3/8 FLAT WASHER SAE ZINC	2
2	044037	3/8-24 NYLOCK HEX NUT PL	2
3	041040	#10-24 x 1 1/2 PH-ROUND HEAD MS SS	2
4	610201	REFLECTOR	1
5	610202	LENS CHANNEL SET SHO LIGHTS	2
6	610203F	LENS GLASS FROSTED	1
7	610207	INTERIOR COVER PLATE WITHOUT HOLE	1
8	610208	INTERIOR COVER PLATE WITH HOLE	1
9	610213	GASKET SOCKET END CAP	2
10	610217	SILICONE GASKET	1
11	045142	3/8-24 x 3/8-16 x 2 STUD	2
12	041028	#10-24 x 1/2 HEX WASHER HEAD INDT	8
13	044019	#10-24 NYLOCK HEX NUT SS	2
14	610206	CASTING END SHO	1
15	047019	NYLON BUSHING 3/4 OD x .385 ID	4
16	660130P	YOKE MOUNT SHO LAMP	1
17	510007	1/2 CORD GRIP	1
18	610214	ELBOW 1/2 SLB SHO ENTRANCE	1
19	610215	1/2 NPT NIPPLE	1
20	610205	SOCKET CASTING END SHO	1
21	610212	CERAMIC SOCKET	1
22	041257	#10-32 x 3/8 SL-HEX WASHER HEAD MS GROUND	1
23	610219	GROUND WIRE LAMPHOLDER SHO ENTRANCE	1

3.1 - PAL 2000 Decal Group (1 of 2)

SN 16-000001 and UP

LIGHT BAR DETAIL

TOP DETAIL

BOTTOM DETAIL

1

2

3

4

5

Allmand

	16 lb (7 kg)
	7 lb (3 kg)
	30 lb (14 kg)
	160 lb (73 kg)
229 lb (104 kg)	

104880

108816

Allmand
For parts and service contact your authorized dealer or visit Allmand on the web at **www.allmand.com** or call **1-800-562-1373**

090465

108827_A

PAL2000 & PAL2500

3.1 - PAL 2000 Decal Group (1 of 2)

SN 16-000001 and UP

Item	Part No.	Part Description	Qty.
1	090270	DECAL ALLMAND GOLD STANDARD 5 1/2	2
2	090465	PARTS & SERVICE DECAL	1
3	104880	DECAL WORDLESS HIGH VOLTAGE	1
4	108810	DECAL OPERATION PAL 2000 & 2500	1
5	108816	DECAL WEIGHTS PAL 2000 & 2500	1

Not for Reproduction

3.1 - PAL 2000 Decal Group (2 of 2)

SN 16-000001 and UP

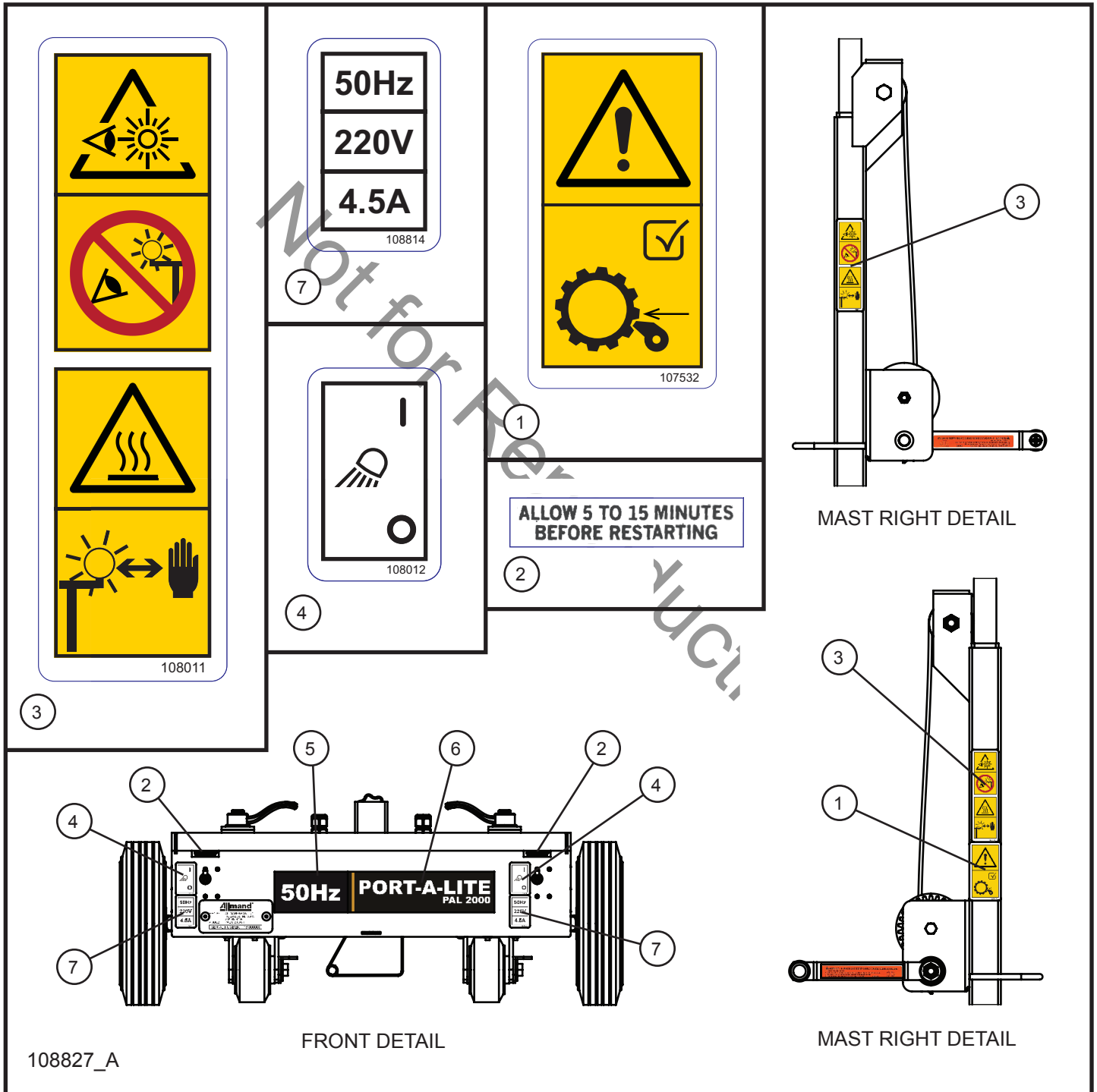

PAL2000 & PAL2500

3.1 - PAL 2000 Decal Group (2 of 2)

SN 16-000001 and UP

Item	Part No.	Part Description	Qty.
1	107532	CAUTION WINCH WORDLESS ARTWORK	1
2	090335	RESTART DECAL	1
3	108011	DECAL LAMP WARNING WORDLESS	2
4	108012	DECAL ON-OFF WORDLESS	1
5	108354	DECAL 50Hz	1
6	108825	DECAL PAL 2000	1
7	108814	DECAL 50Hz ELECTRICAL SPECIFICATIONS	1

Not for Reproduction

3.2 - PAL 2500 Decal Group (1 of 2)

SN 04-000001 and UP

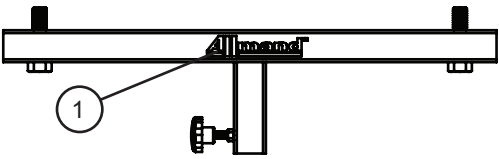

LIGHT BAR DETAIL

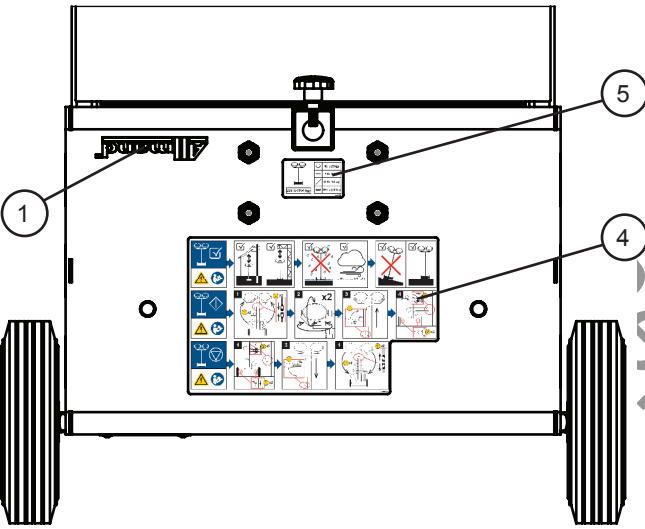

TOP DETAIL

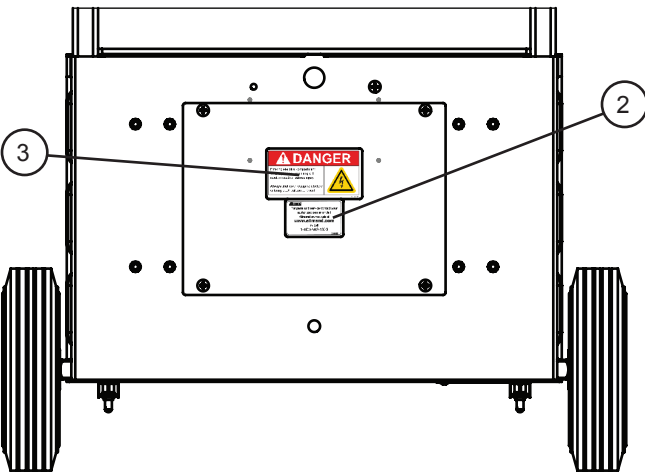

BOTTOM DETAIL



1



3

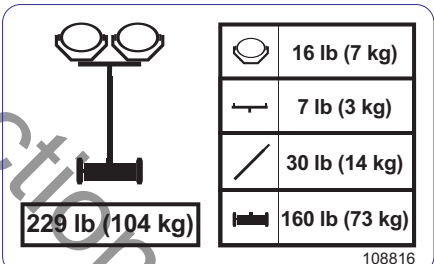

5



2

108828_A

PAL2000 & PAL2500 Parts & Wire Schematic Catalog
©2016 Allmand™ Bros., Inc.

3.2

PAL2000 & PAL2500

3.2 - PAL 2500 Decal Group (1 of 2)

SN 04-000001 and UP

Item	Part No.	Part Description	Qty.
1	090270	DECAL ALLMAND GOLD STANDARD 5 1/2	2
2	090465	PARTS & SERVICE DECAL	1
3	107251	HAZARDOUS VOLTAGE DANGER ARTWORK	1
4	108810	DECAL OPERATION PAL 2000 & 2500	1
5	108816	DECAL WEIGHTS PAL 2000 & 2500	1

Not for Reproduction

3.2 - PAL 2500 Decal Group (2 of 2)

SN 04-000001 and UP

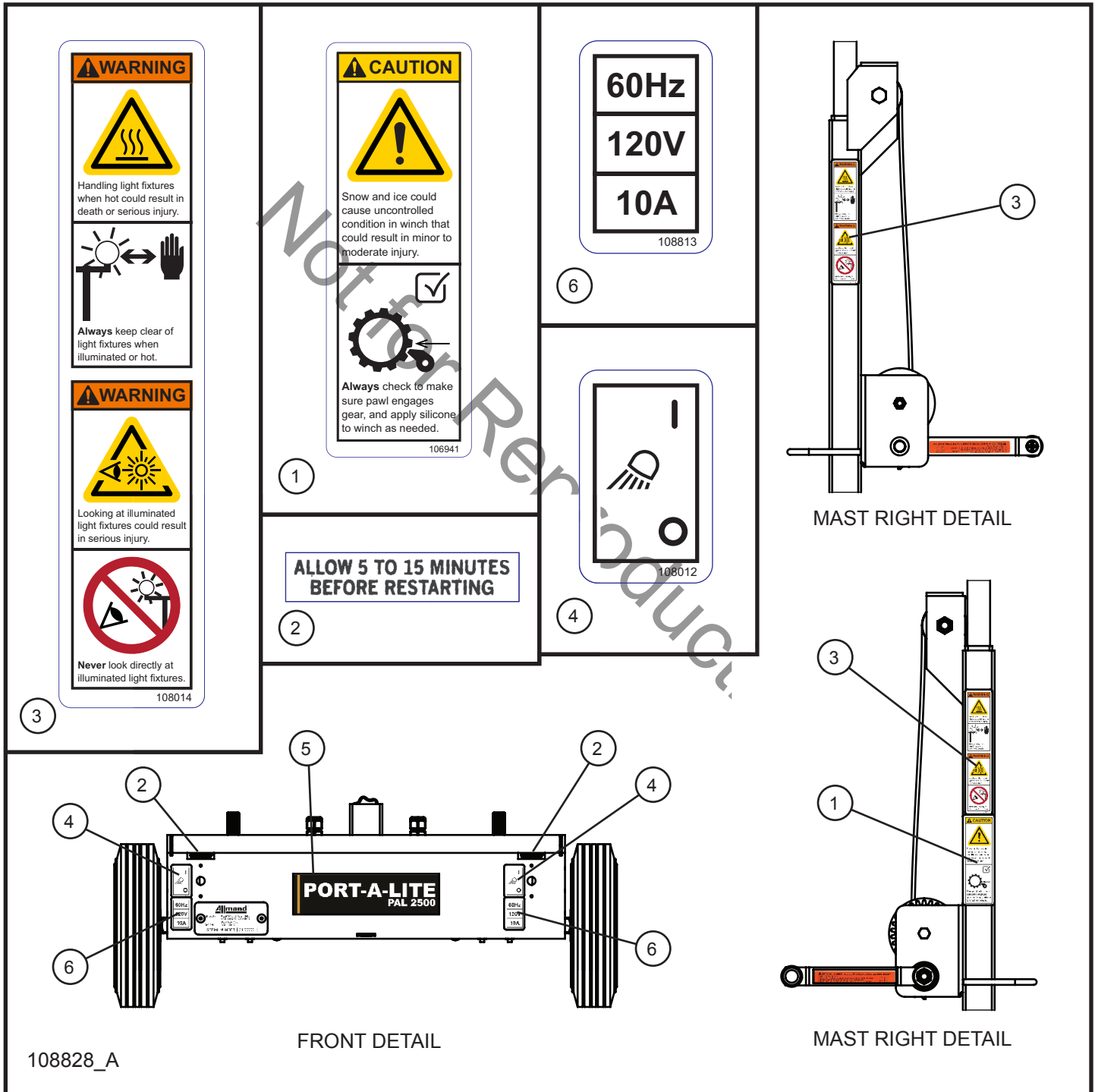

PAL2000 & PAL2500

3.2 - PAL 2500 Decal Group (2 of 2)

SN 04-000001 and UP

Item	Part No.	Part Description	Qty.
1	106941	CAUTION WINCH ICY CONDITIONS DECAL	1
2	090335	RESTART DECAL	1
3	108014	DECAL WARNING DO NOT LOOK	2
4	108012	DECAL ON-OFF WORDLESS	1
5	108826	DECAL PAL 2500	1
6	108813	DECAL 60Hz ELECTRICAL SPECIFICATIONS	1

Not for Reproduction

4.1 - PAL 1000 50Hz Base Schematic (1 of 2)

SN 16-000001 and UP

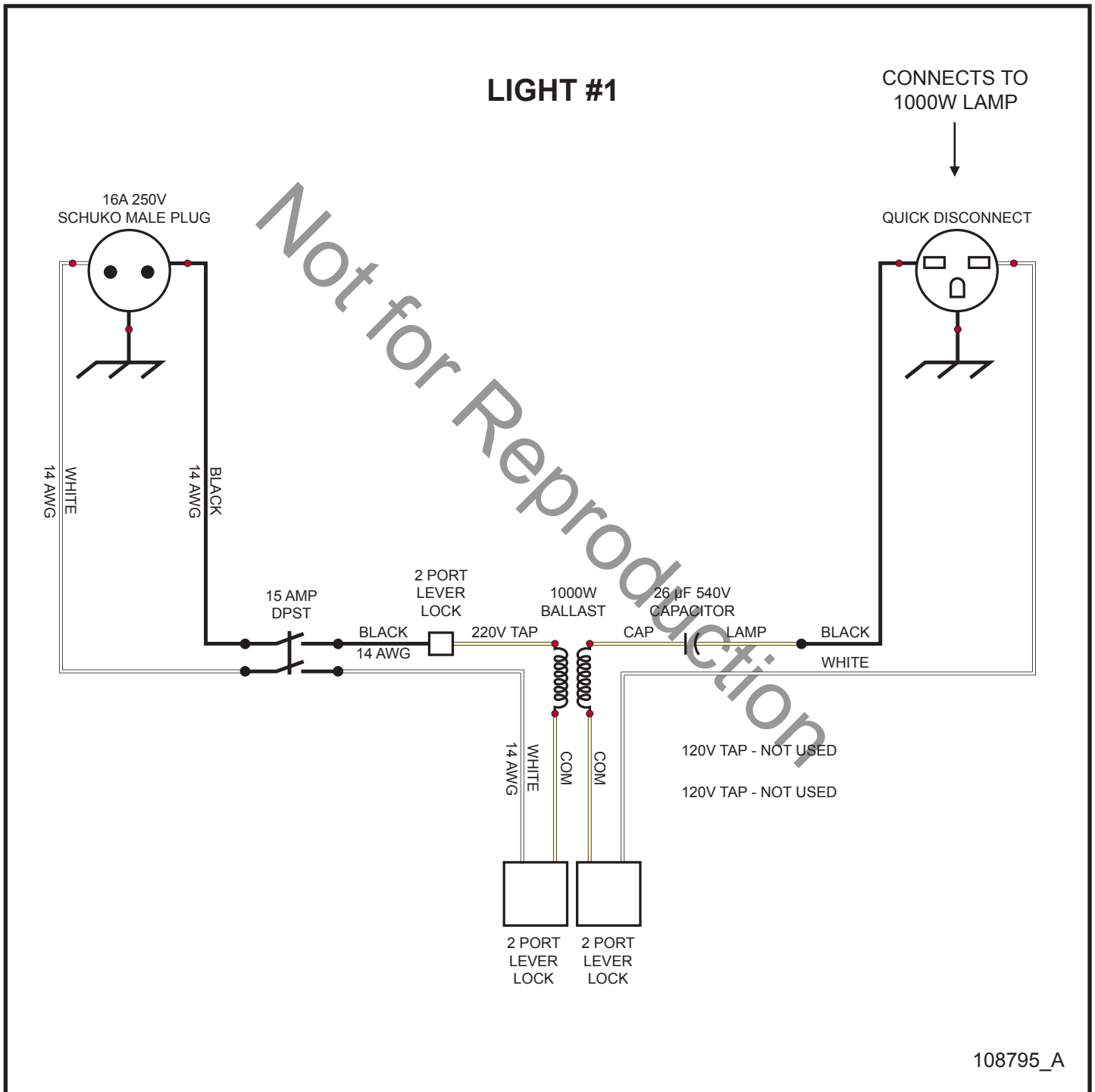

PAL2000 & PAL2500

4.1 - PAL 1000 50Hz Base Schematic (2 of 2)

SN 16-000001 and UP

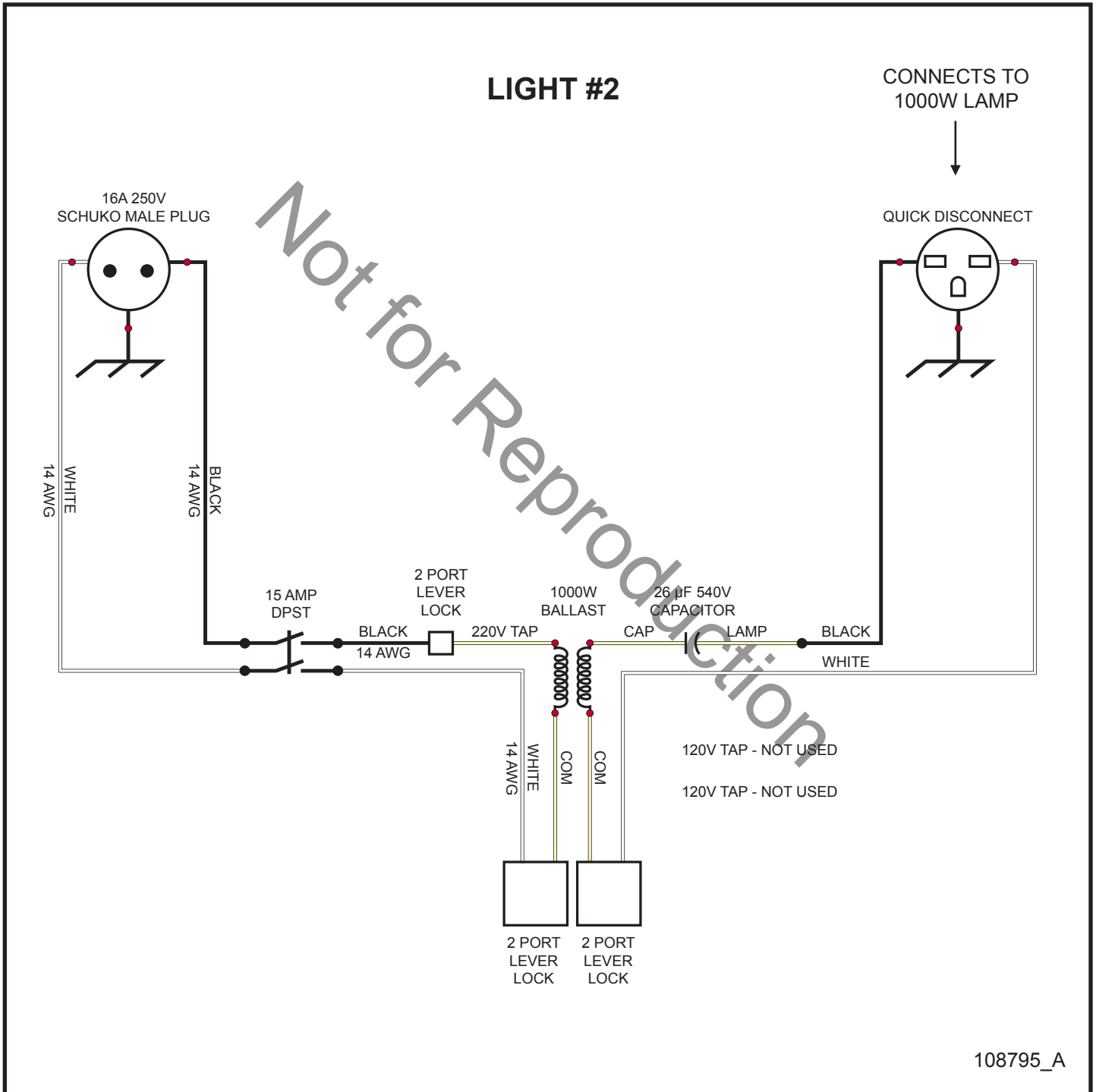

4.2 - PAL 1250 60Hz Base Schematic (1 of 2)

SN 04-000001 and UP

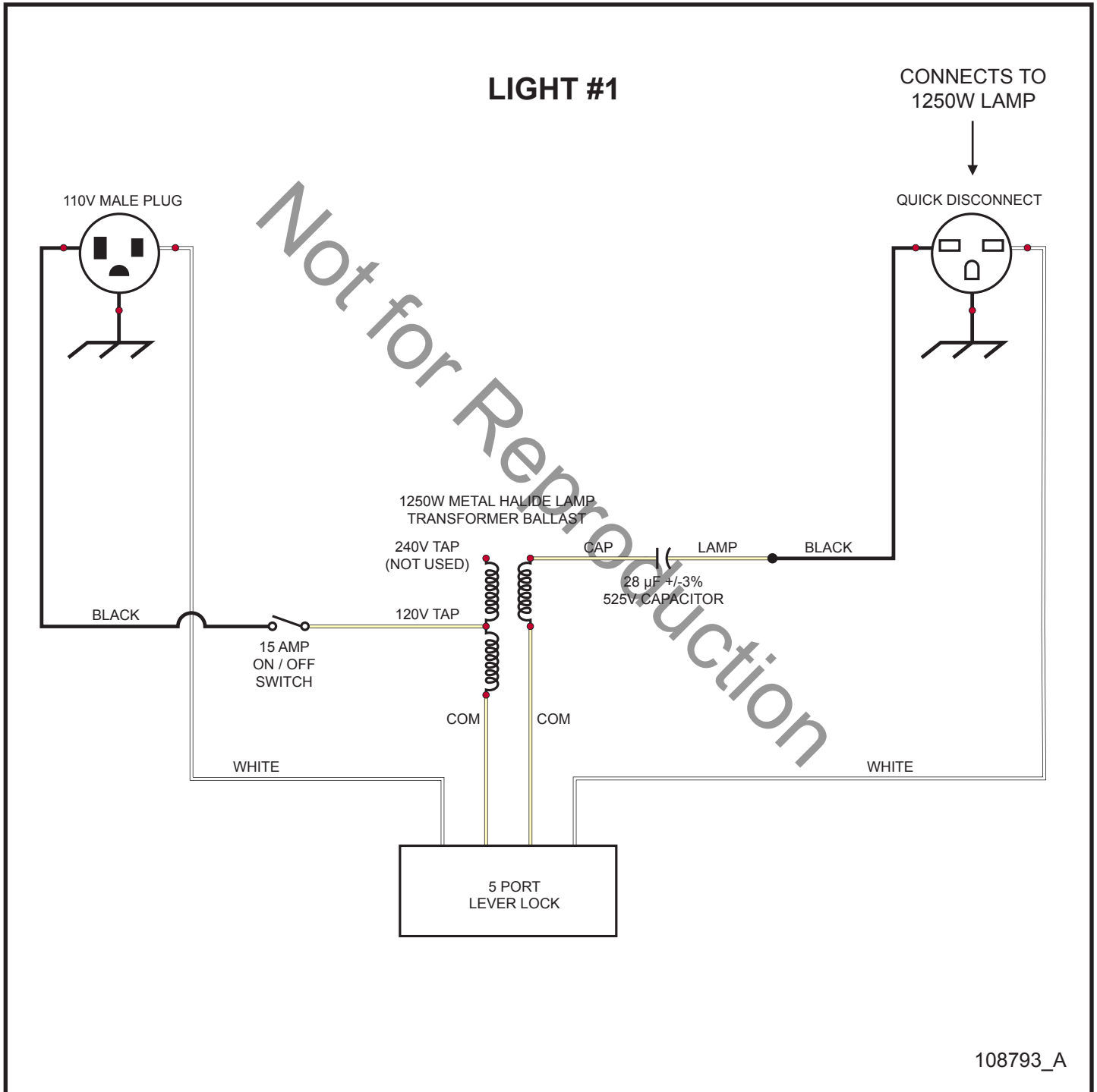

PAL2000 & PAL2500

4.2 - PAL 1250 60Hz Base Schematic (2 of 2)

SN 04-000001 and UP

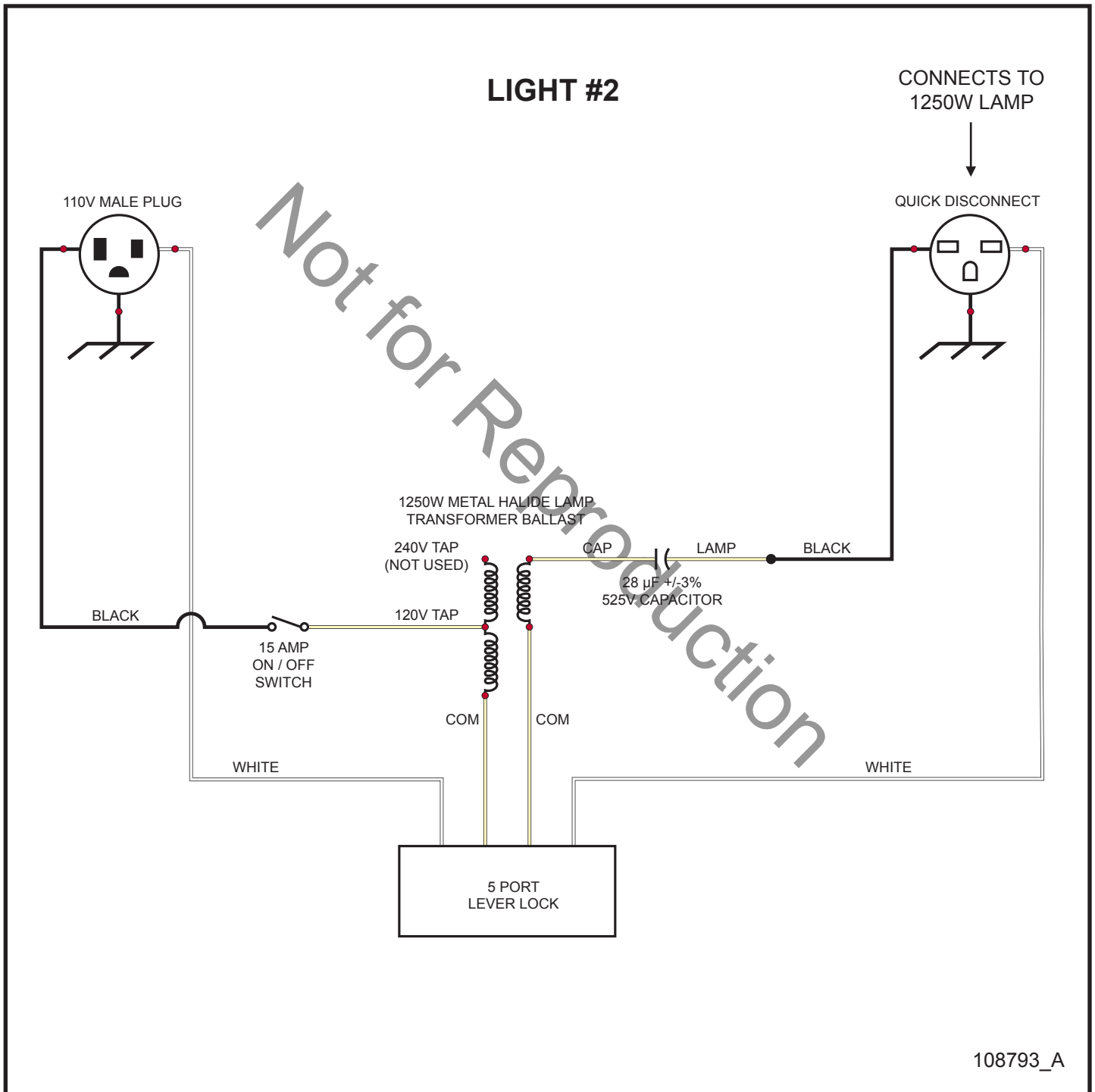

Allmand™

BRIGHTER. WARMER. SAFER.

Allmand Bros., Inc.
1502 West 4th Avenue
Holdrege, NE 68949
phone: (308) 995-4495 • toll free: (800) 562-1373
fax: (308) 995-5887

www.allmand.com



Reliability, performance, and integrity since 1938

13-0267