

(en) Schematic Manual
MAXI-LITE[®]

TABLE OF CONTENTS

Tail Light and Electric Brake Harness Schematic (114032)	(1.1)
6/4 50/60Hz 6/8kW Generator Cord Schematic (115223)	(1.2)
4/4 50/60Hz 11/15kW Generator Cord Schematic (115225)	(1.3)
2/4 60Hz 20kW 1PH Generator Cord Schematic (115224)	(1.4)
4/5 60Hz 20kW 3PH Generator Cord Schematic (115226)	(1.5)
SLS Relay Schematic (106877)	(1.6)
LSC 2.1 Transformer Schematic (108058)	(1.7)
Kubota D1005 Engine Harness Schematic (108044)	(1.8)
Kubota D1105 Engine Harness Schematic (112776)	(1.9)
CAT C1.1 Engine Harness Schematic (110112)	(1.10)
CAT C1.5T Engine Harness Schematic (106553)	(1.11)
Isuzu 4LE2T T4F Engine Harness Schematic (107927)	(1.12)
SLS / Key Start Schematic (110123)	(1.13)
LSC / SLS Schematic (113652)	(1.14)
Low Fuel Module Schematic (105901)	(1.15)
Low Fuel Sender Schematic (110089)	(1.16)
2-GFCI, 2-30A Twistlock, 1-30A RV 8kW Outlet Schematic (114027)	(1.17)
2-GFCI, 4-30A Twistlock 15/20kW Outlet Schematic (114026)	(1.18)
2-GFCI, 2-30A Twistlock, 1-30A RV, 1-50A RV 15/20kW Outlet Schematic (117452)	(1.19)
2-GFCI, 2-30A RV, 2-50A RV 15/20kW Outlet Schematic (117461)	(1.20)
2-GFCI, 3-30A Twistlock, 1-50A Twistlock 15/20kW Outlet Schematic (114025)	(1.21)
60A 3P Auxiliary Outlet Schematic (115261)	(1.22)
4-Light 1P Relay Schematic (114021)	(1.23)
4-Light 3P Relay Schematic (114023)	(1.24)
6-Light 1P Relay Schematic (114022)	(1.25)

Maxi-Lite

TABLE OF CONTENTS

6-Light 3P Relay Schematic (114024)	(1.26)
4-Light SHO 16/8 Cord Junction Box Schematic (113626)	(1.27)
6-Light SHO 16/10 Cord Junction Box Schematic (113627)	(1.28)
4-Light LED 16/8 Cord Junction Box Schematic (113624)	(1.29)
6-Light LED 16/14 Cord Junction Box Schematic (113625)	(1.30)
1000W 60Hz 120V Ballast Schematic (105287)	(1.31)
1000W 60Hz 120V HPS Ballast Schematic (105184)	(1.32)
1000W 50Hz 120V Ballast Schematic (105288)	(1.33)
1000W 50Hz 220V Ballast Schematic (105289)	(1.34)
1250W 60Hz 120V Ballast Schematic (105286)	(1.35)
1-4 LED Drivers Schematic (117355)	(1.36)
5-6 LED Drivers Schematic (110094)	(1.37)
4-Light SHO 16/8 Cord Light Bar Schematic (105292)	(1.38)
6-Light SHO 16/10 Cord Light Bar Schematic (105293)	(1.39)
4-Light LED 16/8 Cord Light Bar Schematic (117357)	(1.40)
6-Light LED 16/14 Cord Light Bar Schematic (117359)	(1.41)
Solid Wired SHO Lamp Schematic (105294)	(1.42)
Quick Disconnect SHO Lamp Schematic (105295)	(1.43)
Vertical Hydraulic Powered Schematic (113143)	(1.44)
Isuzu Heated Fuel/Water Separator Schematic (117335)	(1.45)
LSC or SLS Heated Fuel/Water Separator Schematic (105886)	(1.46)
Shocker Valve Harness Schematic (106156)	(1.47)
Fuel Run Beacon Schematic (115127 & 117407)	(1.48)
Low Fuel Beacon Schematic (115128 & 117406)	(1.49)
Interior Work Light Schematic (115247)	(1.50)
Diesel Fired Block Heater Schematic (106045)	(1.51)

1.1 - Tail Light and Electric Brake Harness Schematic

No Connections

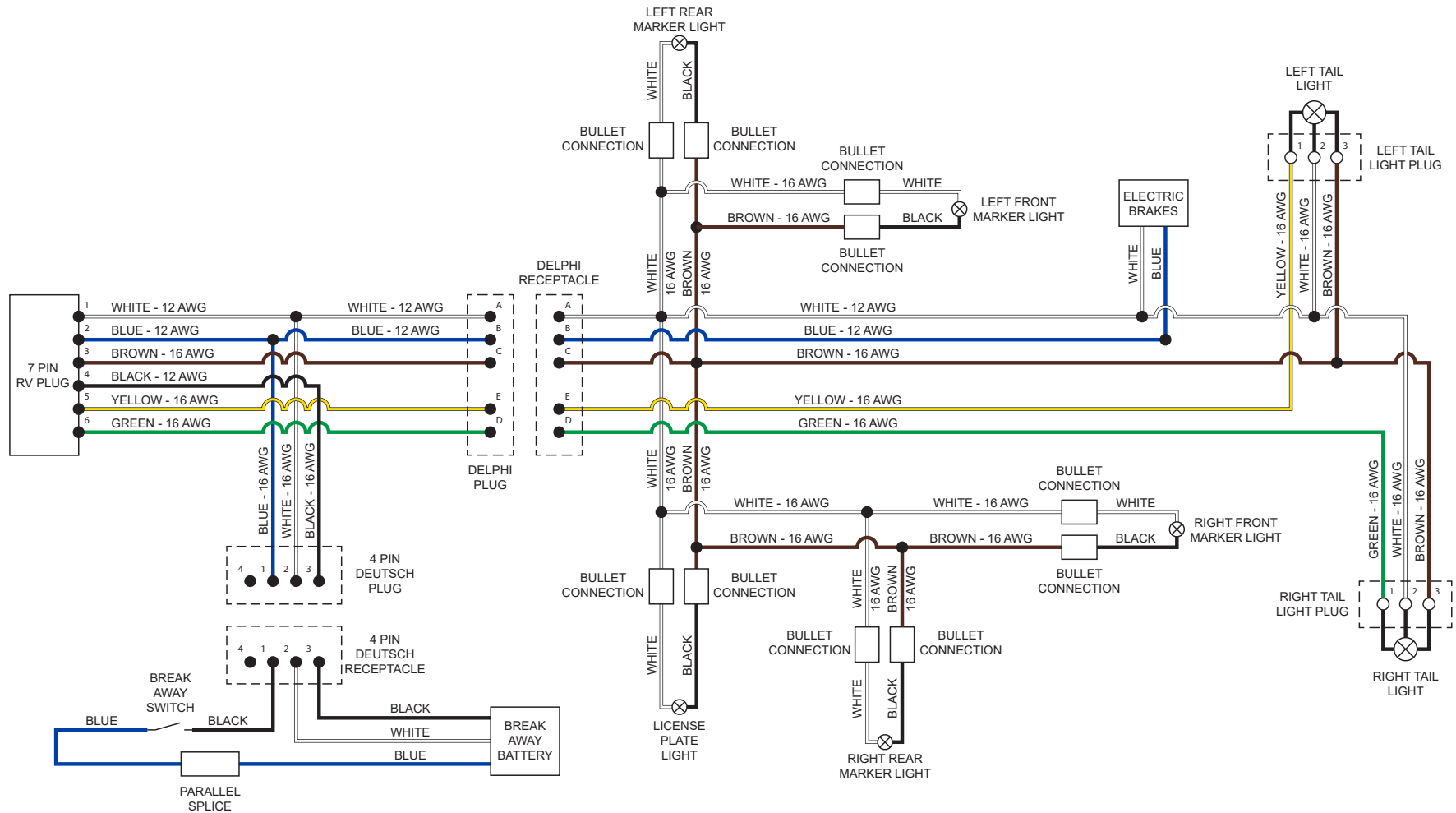

114032

Maxi-Lite

1.2 - 6/4 50/60Hz 6/8kW Generator Cord Schematic

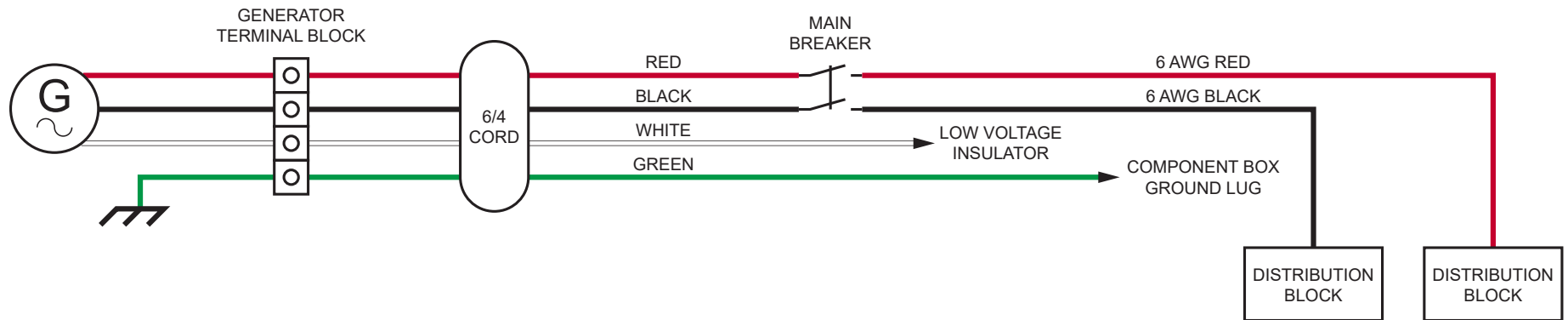

GENERATOR TERMINAL BLOCK CONNECTIONS				
6/4 CORD WIRE	MARATHON 50/60 Hz	ATHLON 50/60 Hz	COLISEUM 60 Hz	COLISEUM 50 Hz
RED	3	L1	11	11
WHITE	2	L2	33	33
BLACK	1	L3	44	66
GREEN	GROUND STUD	GROUND STUD	22	55

115223

1.3 - 4/4 50/60Hz 11/15kW Generator Cord Schematic

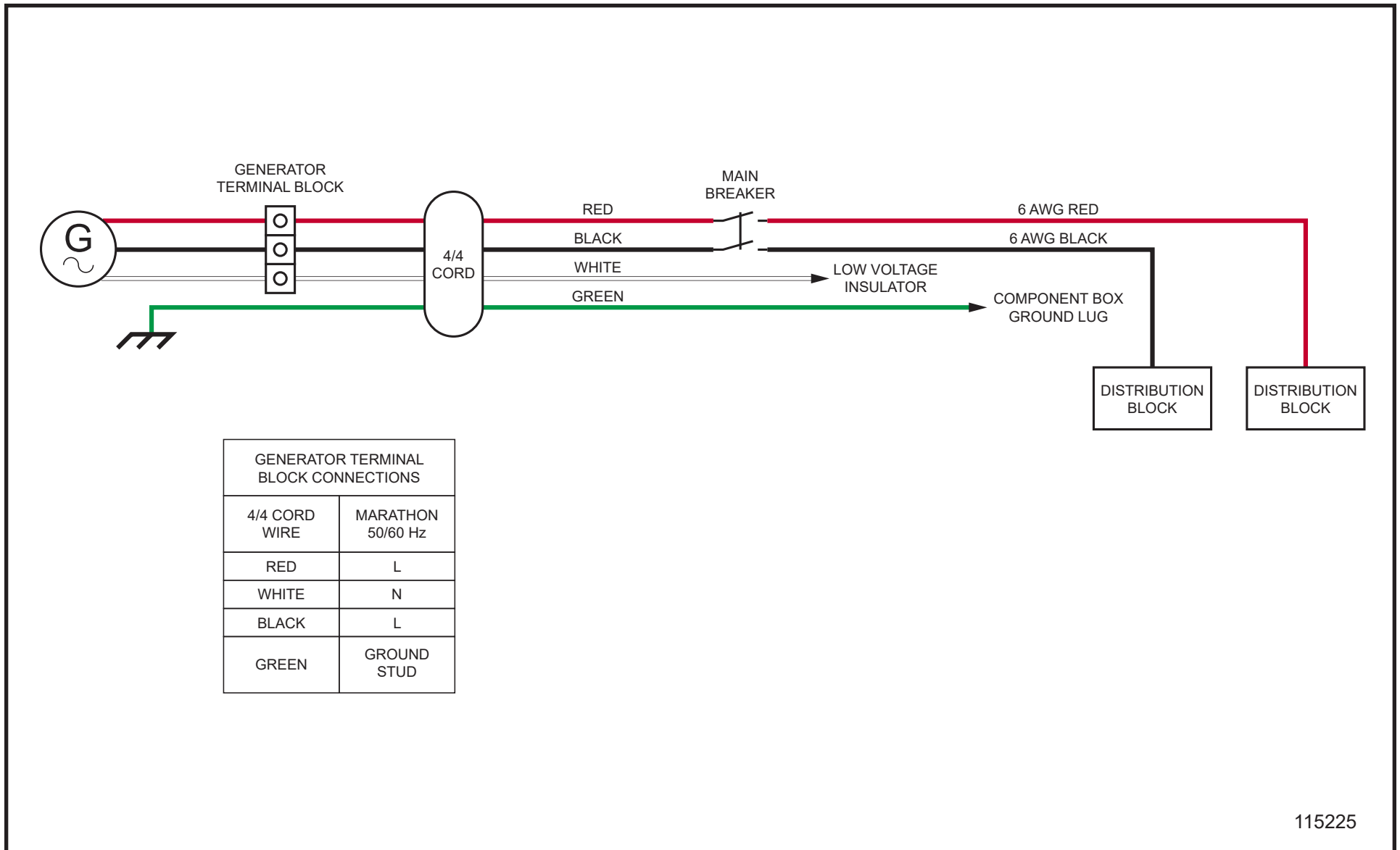

115225

Maxi-Lite

1.4 - 2/4 60Hz 20kW 1PH Generator Cord Schematic

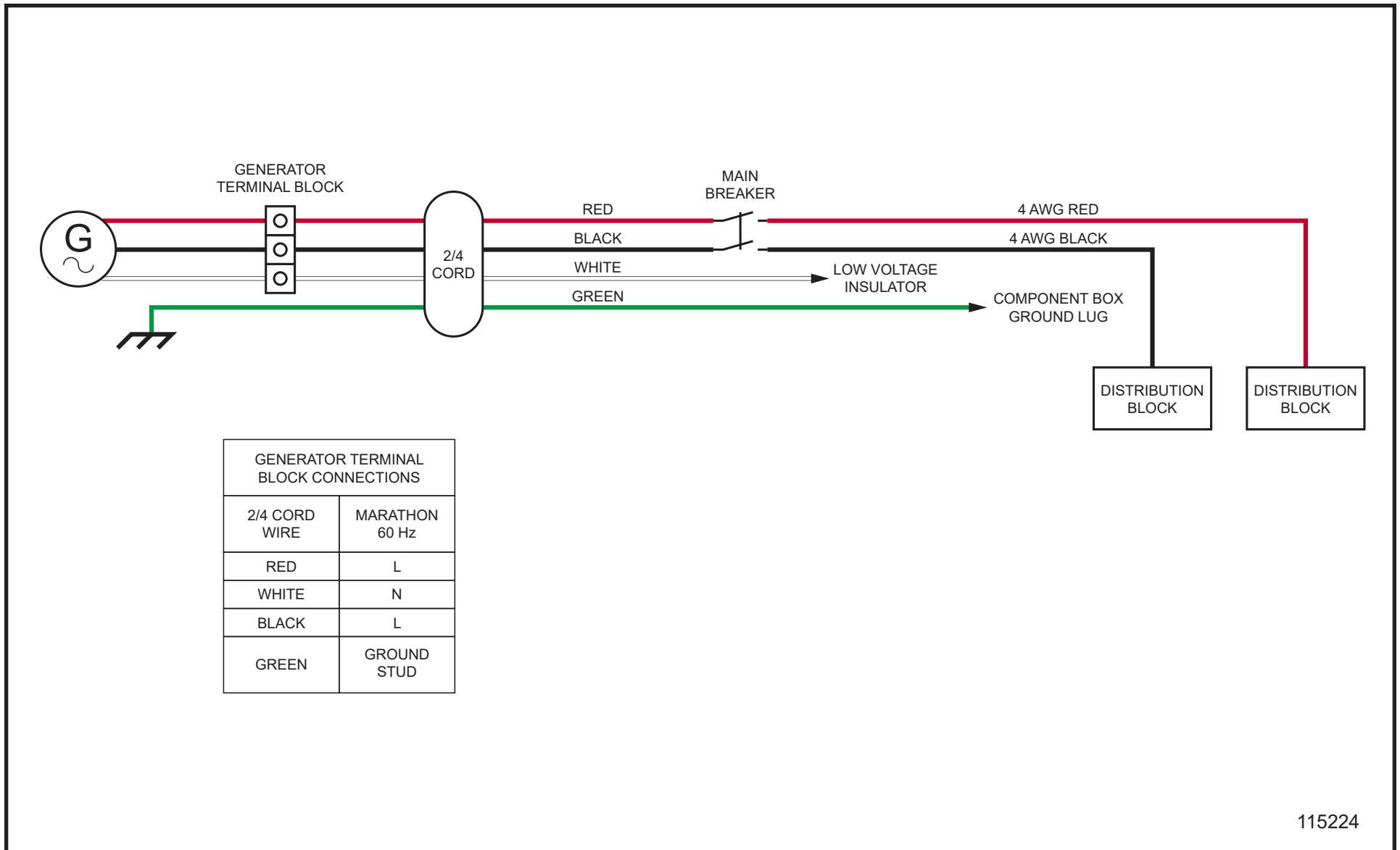

1.5 - 4/5 60Hz 20kW 3PH Generator Cord Schematic

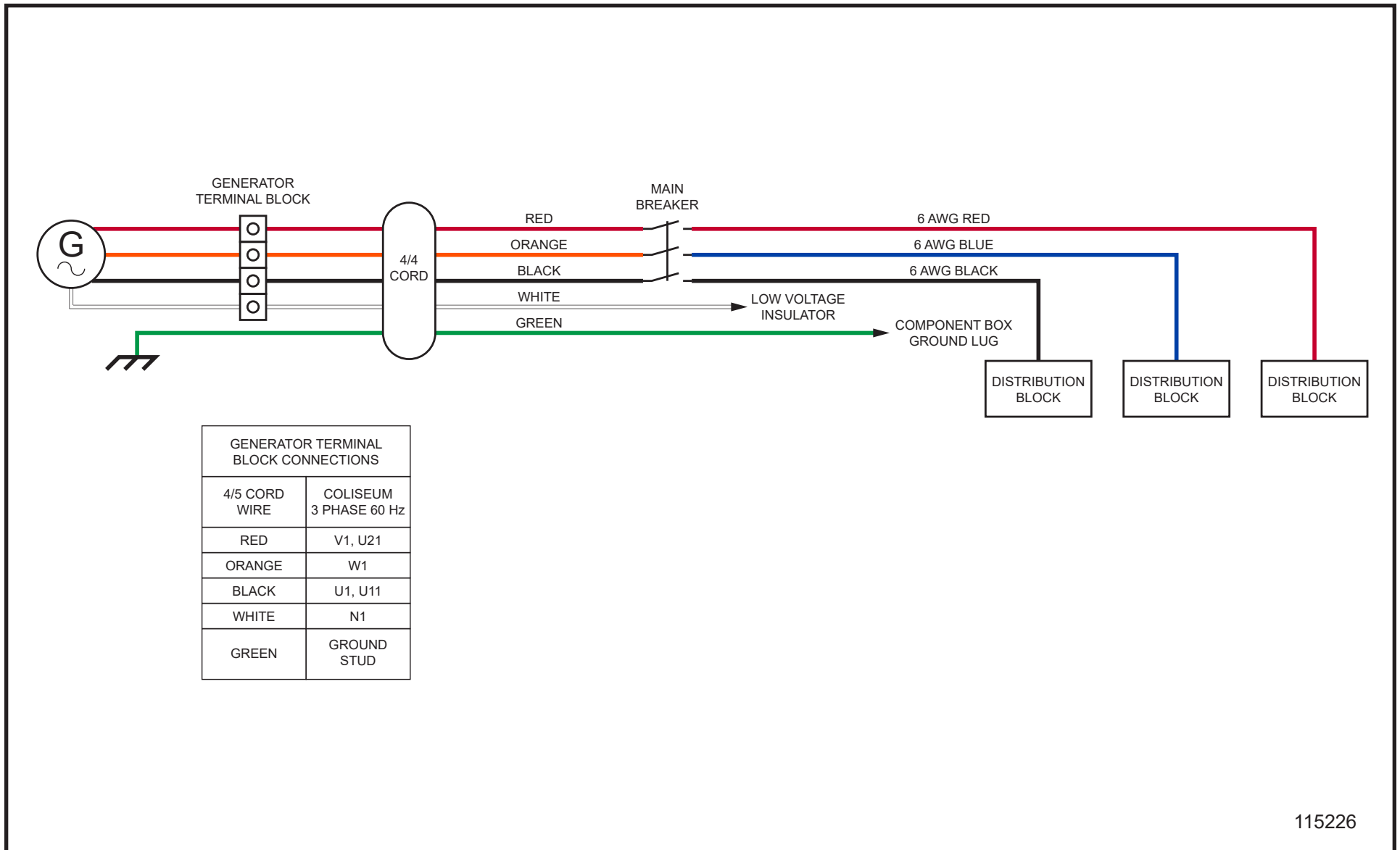

115226

1.6 - SLS Relay Schematic

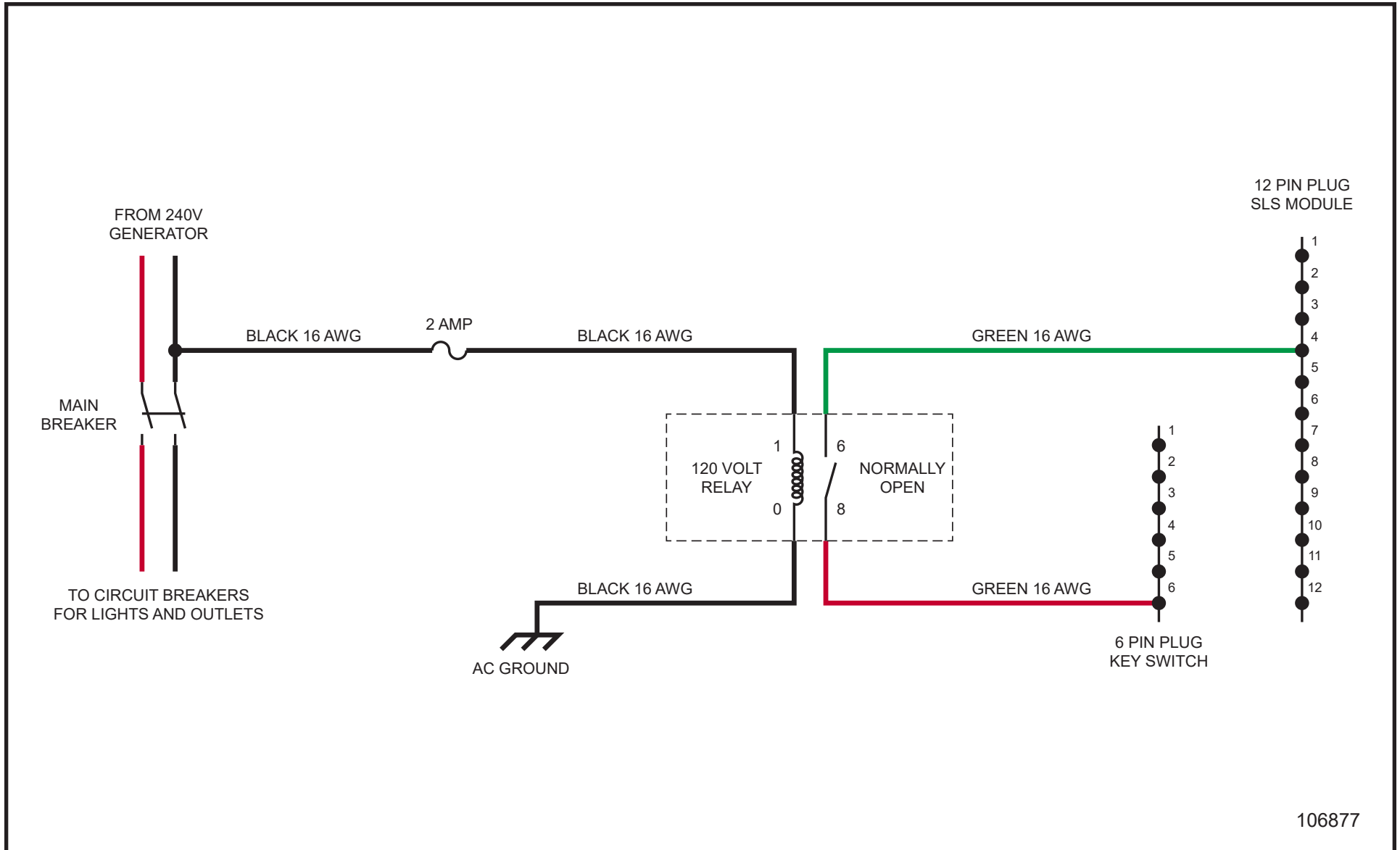

1.7 - LSC 2.1 Transformer Schematic

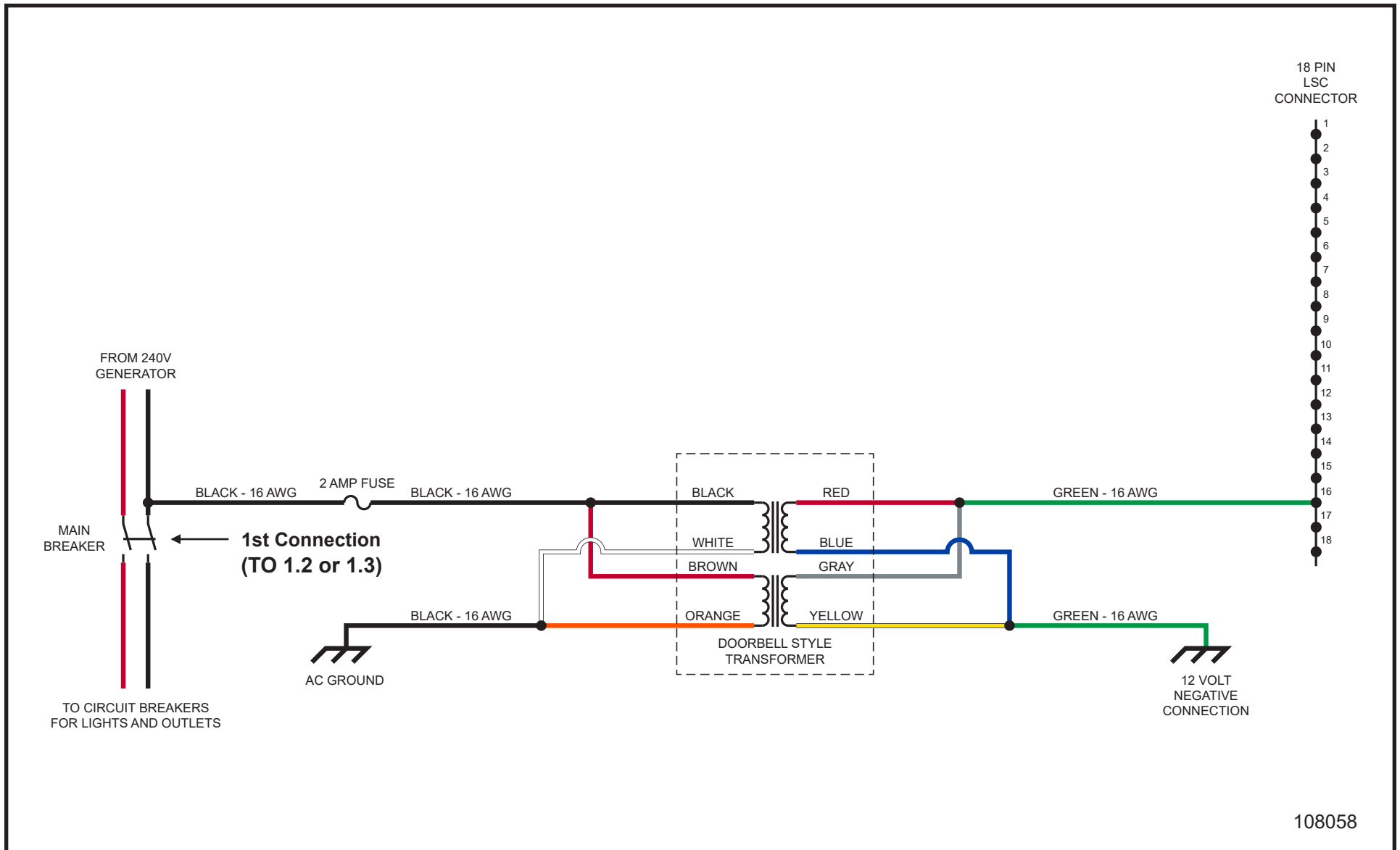

Maxi-Lite

1.8 - Kubota D1005 Engine Harness Schematic

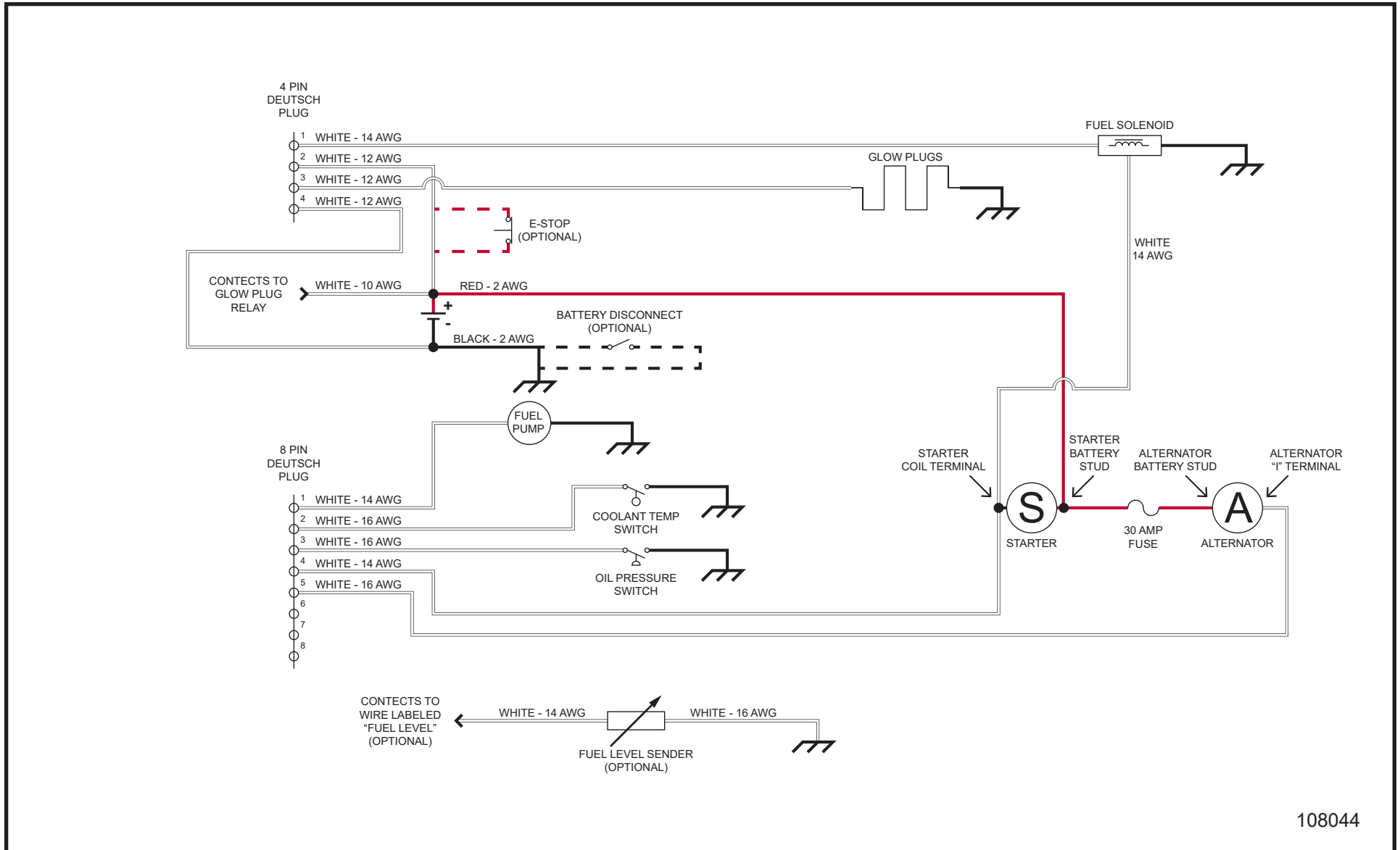

108044

1.9 - Kubota D1105 Engine Harness Schematic

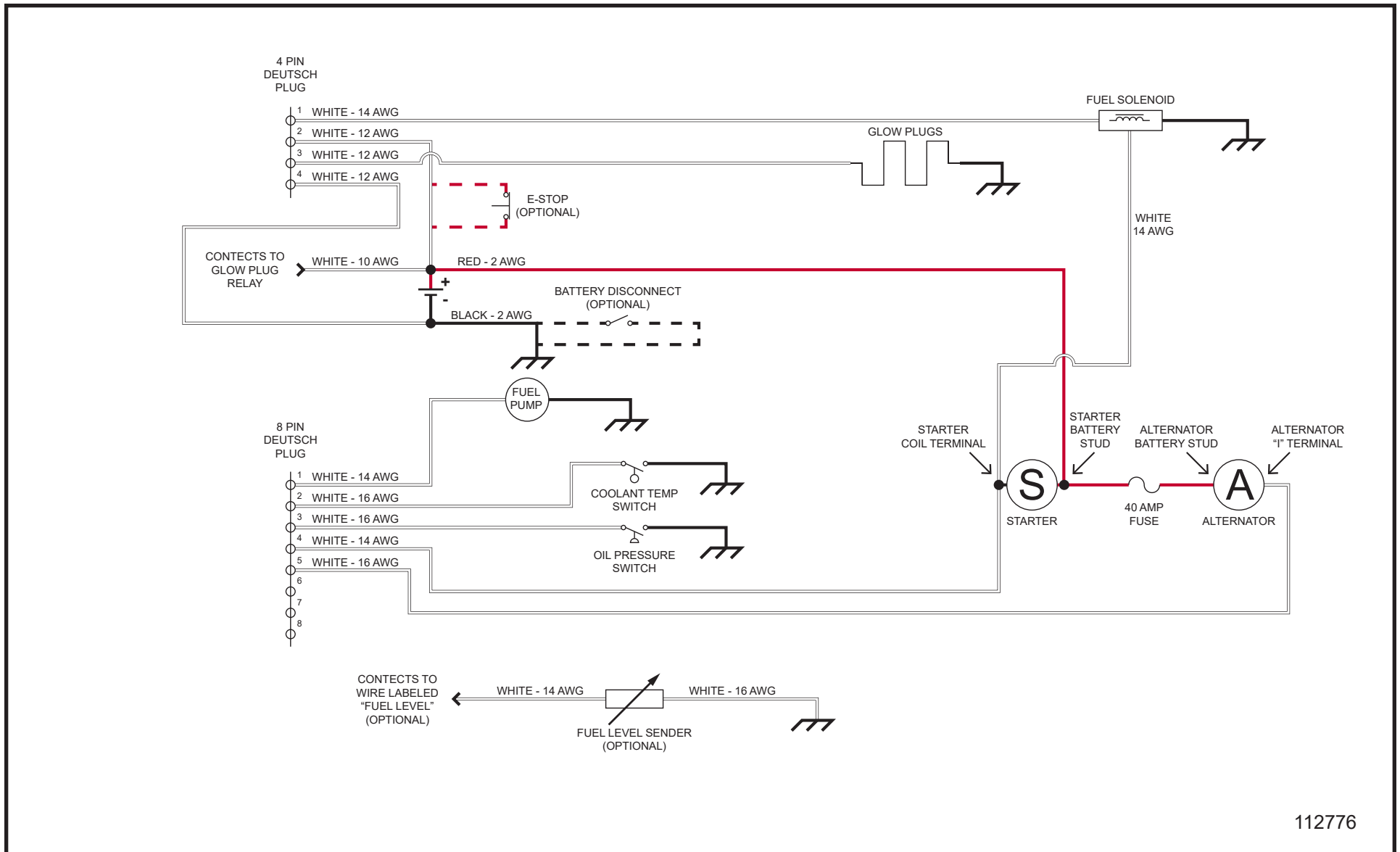

112776

Maxi-Lite

1.10 - CAT C1.1 Engine Harness Schematic

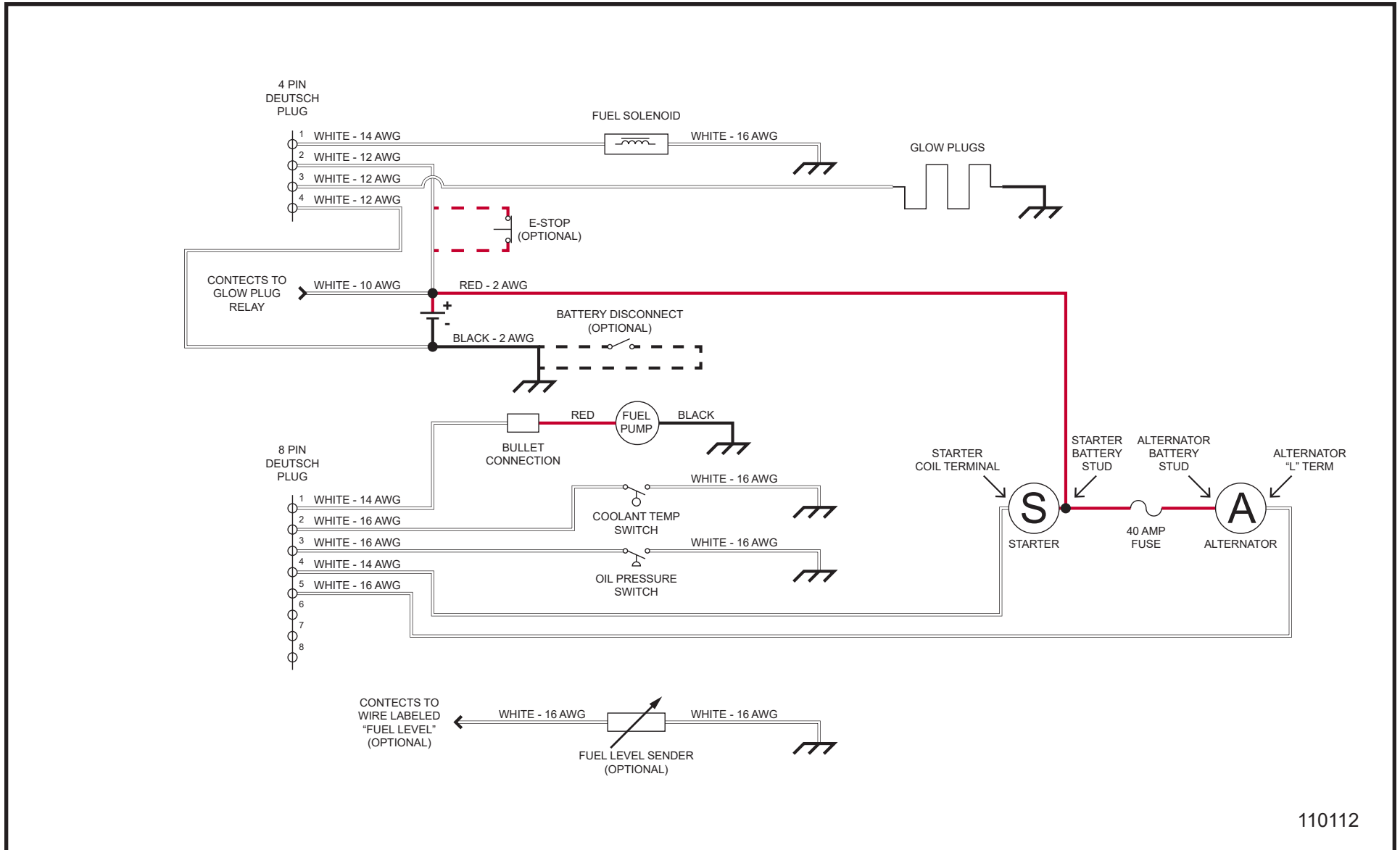

110112

1.11 - CAT C1.5T Engine Harness Schematic

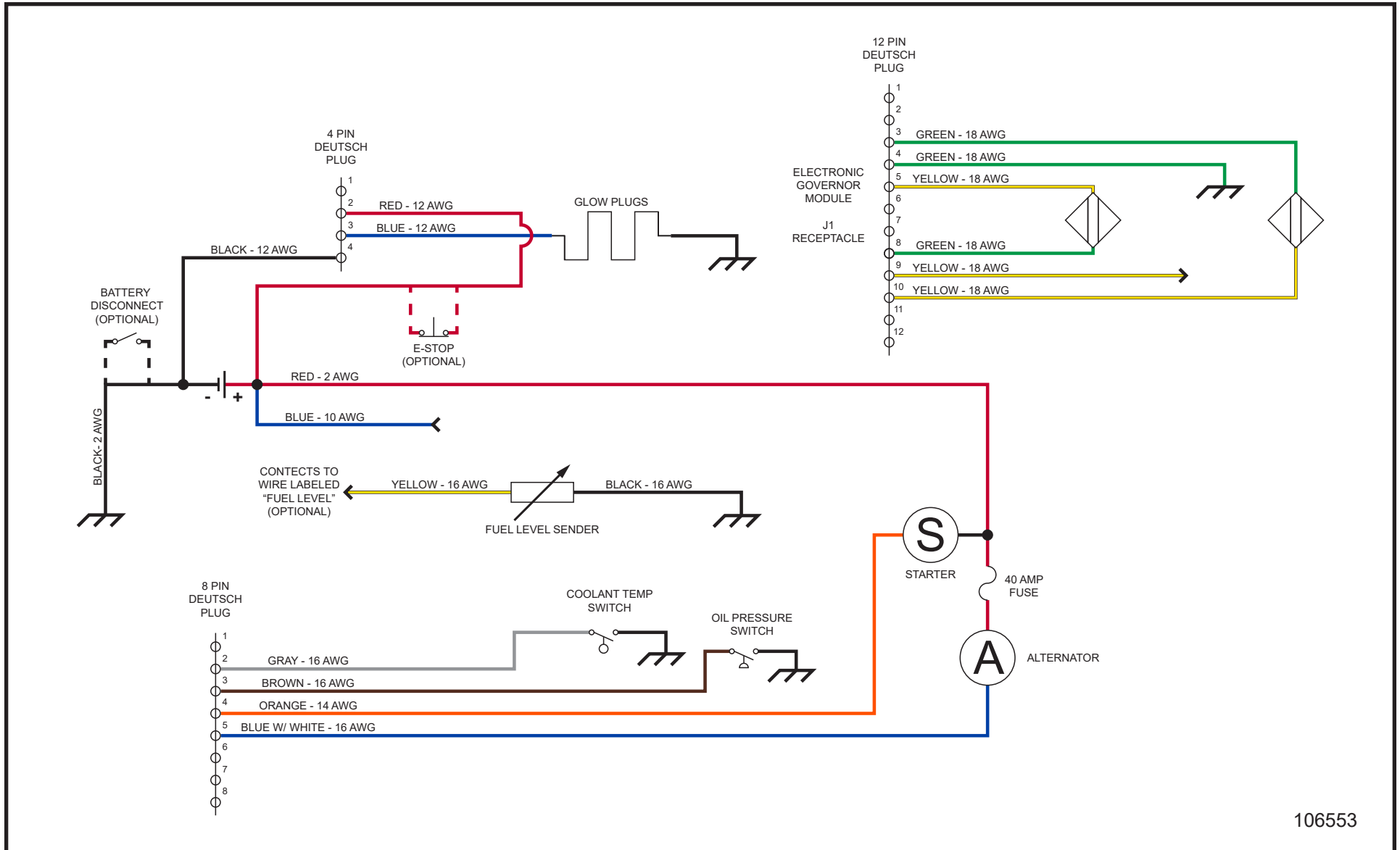

106553

Maxi-Lite

1.12 - Isuzu 4LE2T T4F Engine Harness Schematic (1 of 3)

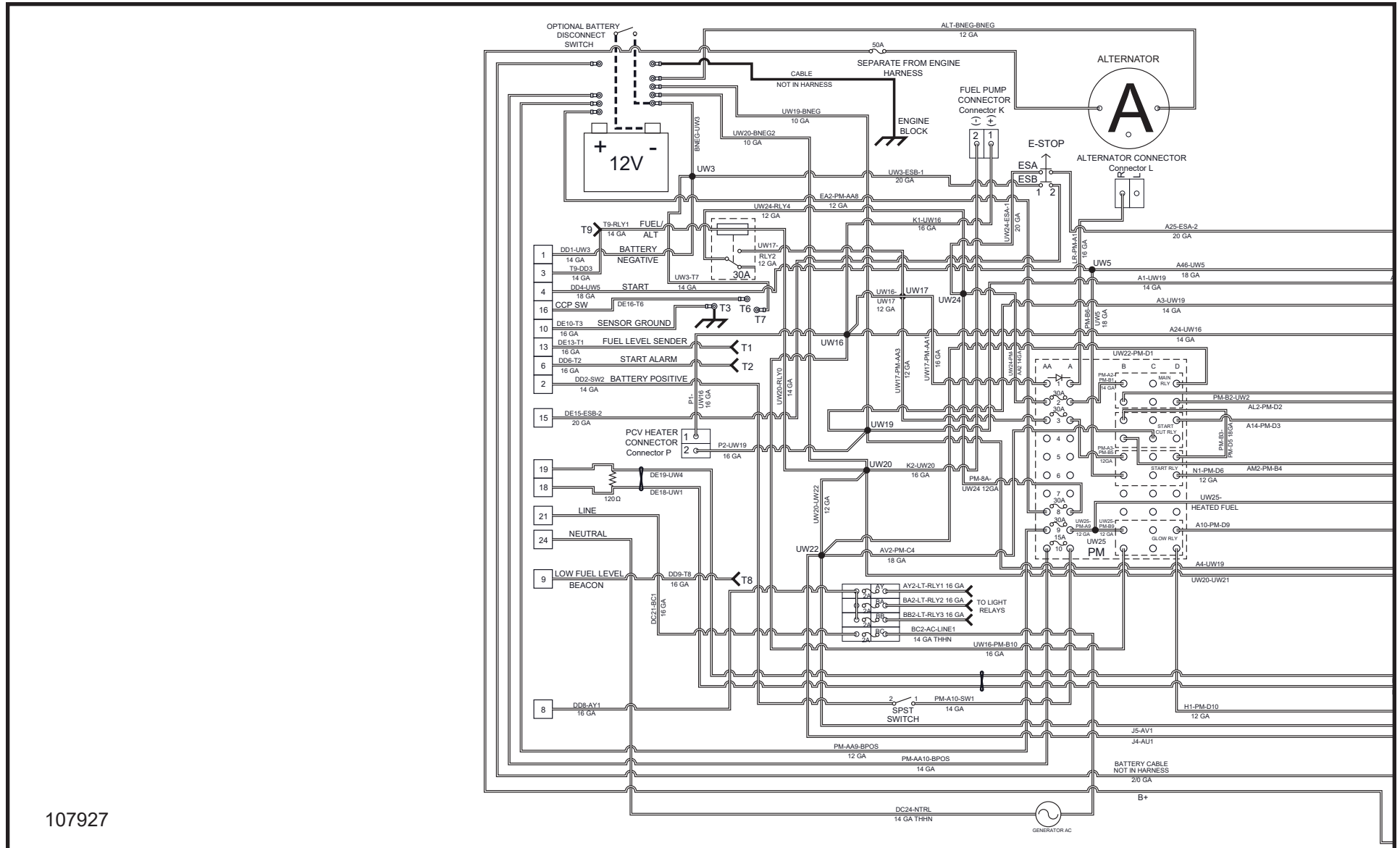

1.12 - Isuzu 4LE2T T4F Engine Harness Schematic (2 of 3)

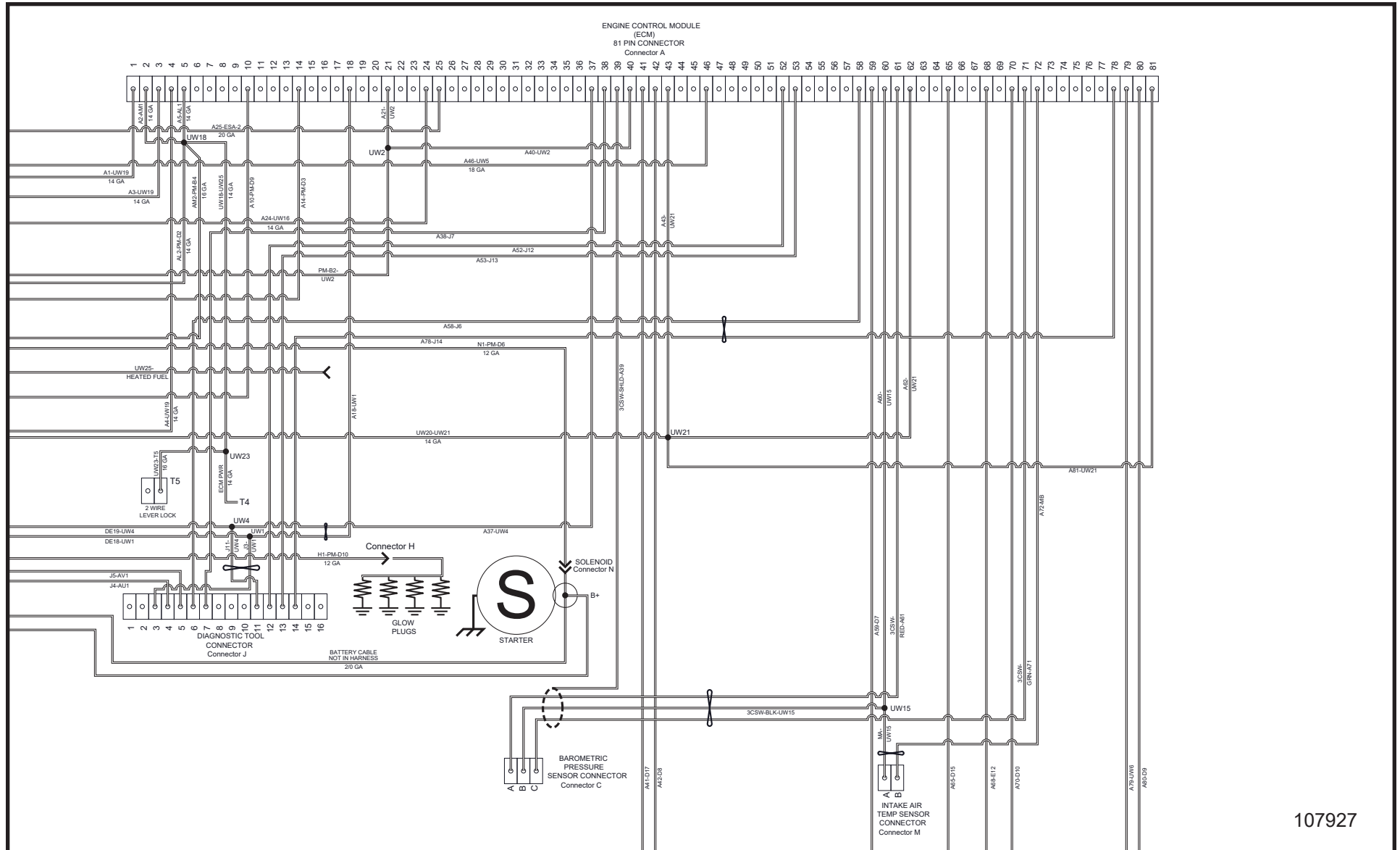

107927

Maxi-Lite

1.12 - Isuzu 4LE2T T4F Engine Harness Schematic (3 of 3)

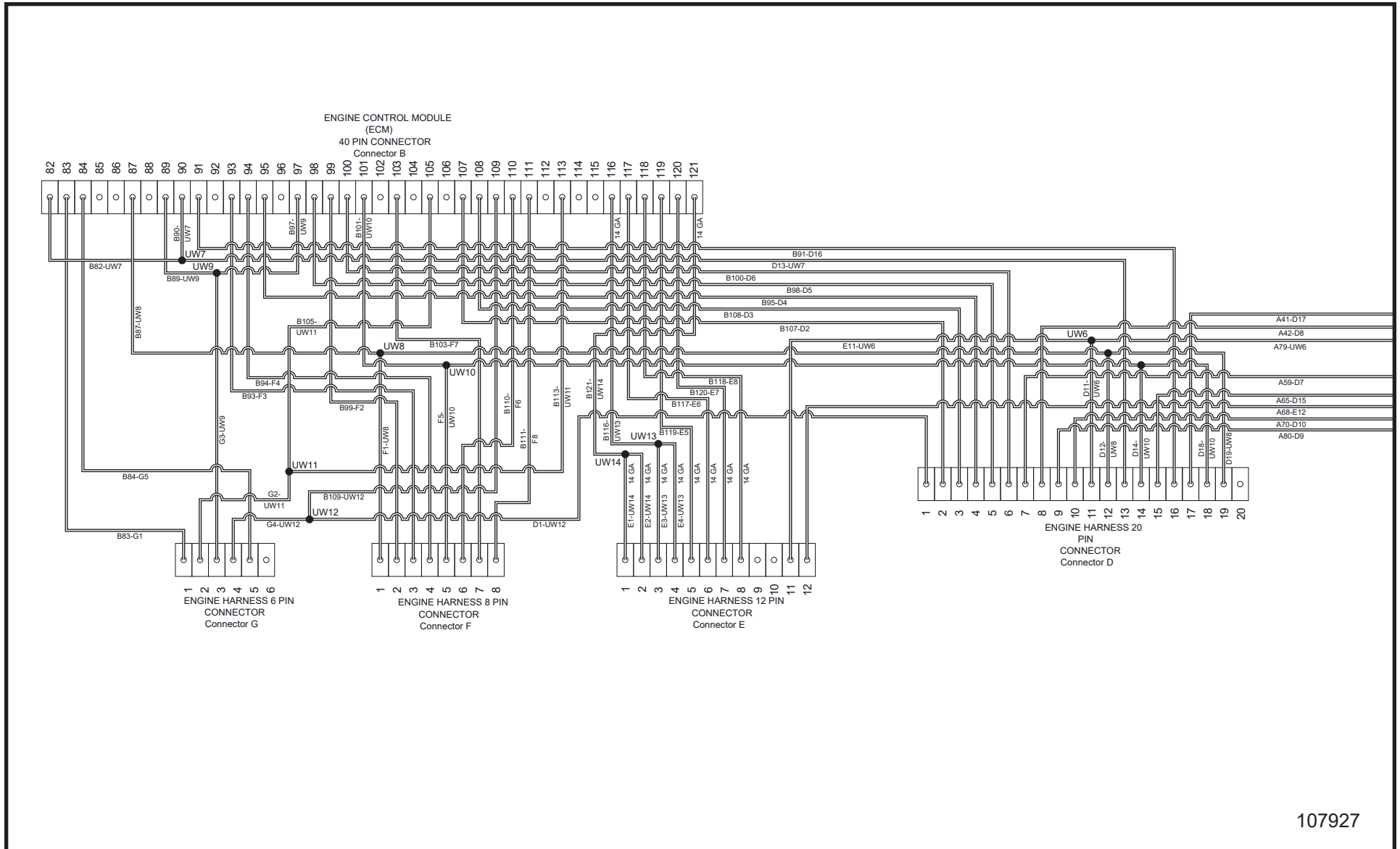

107927

Maxi-Lite

1.14 - LSC / SLS Schematic

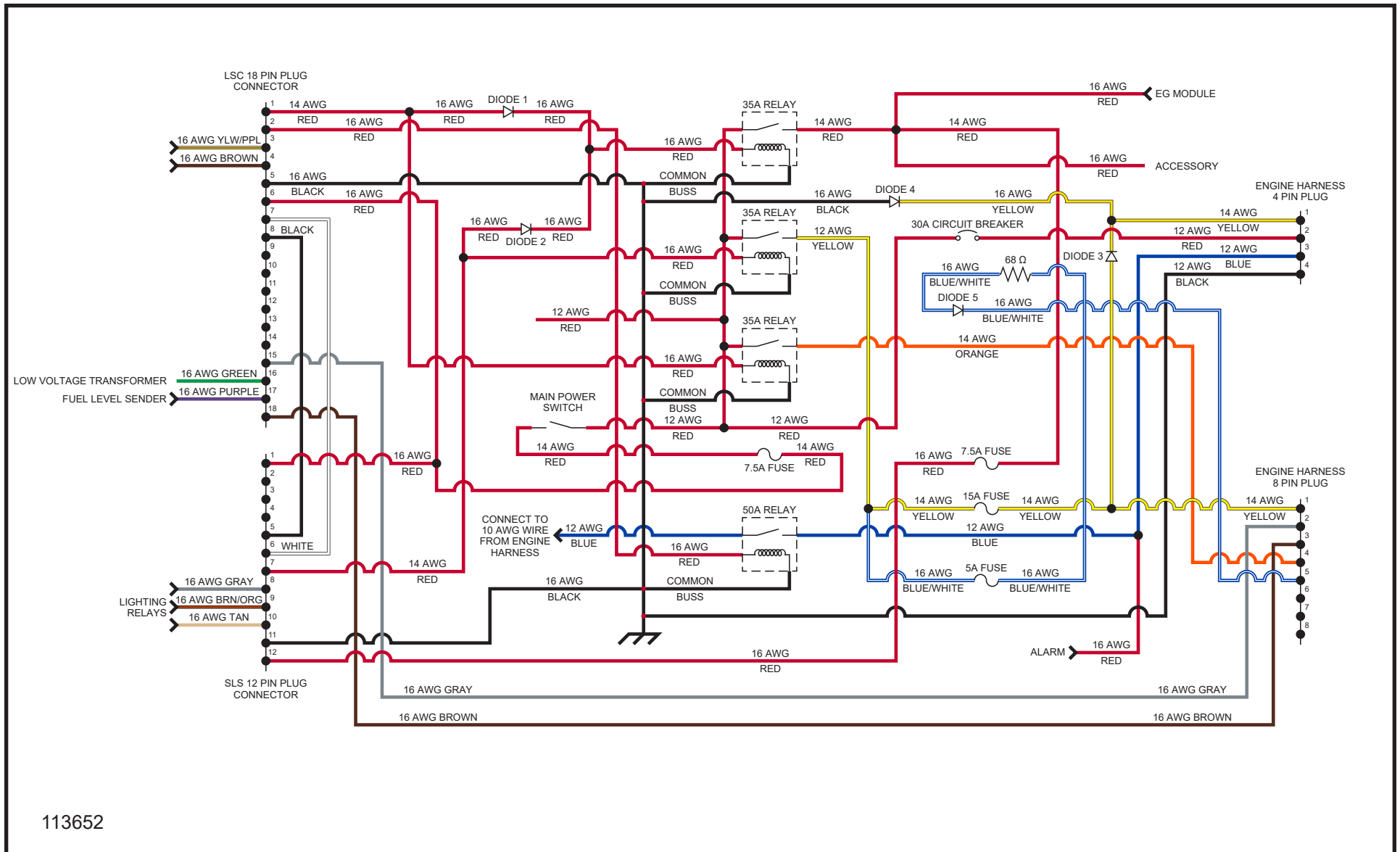

113652

1.15 - Low Fuel Module Schematic

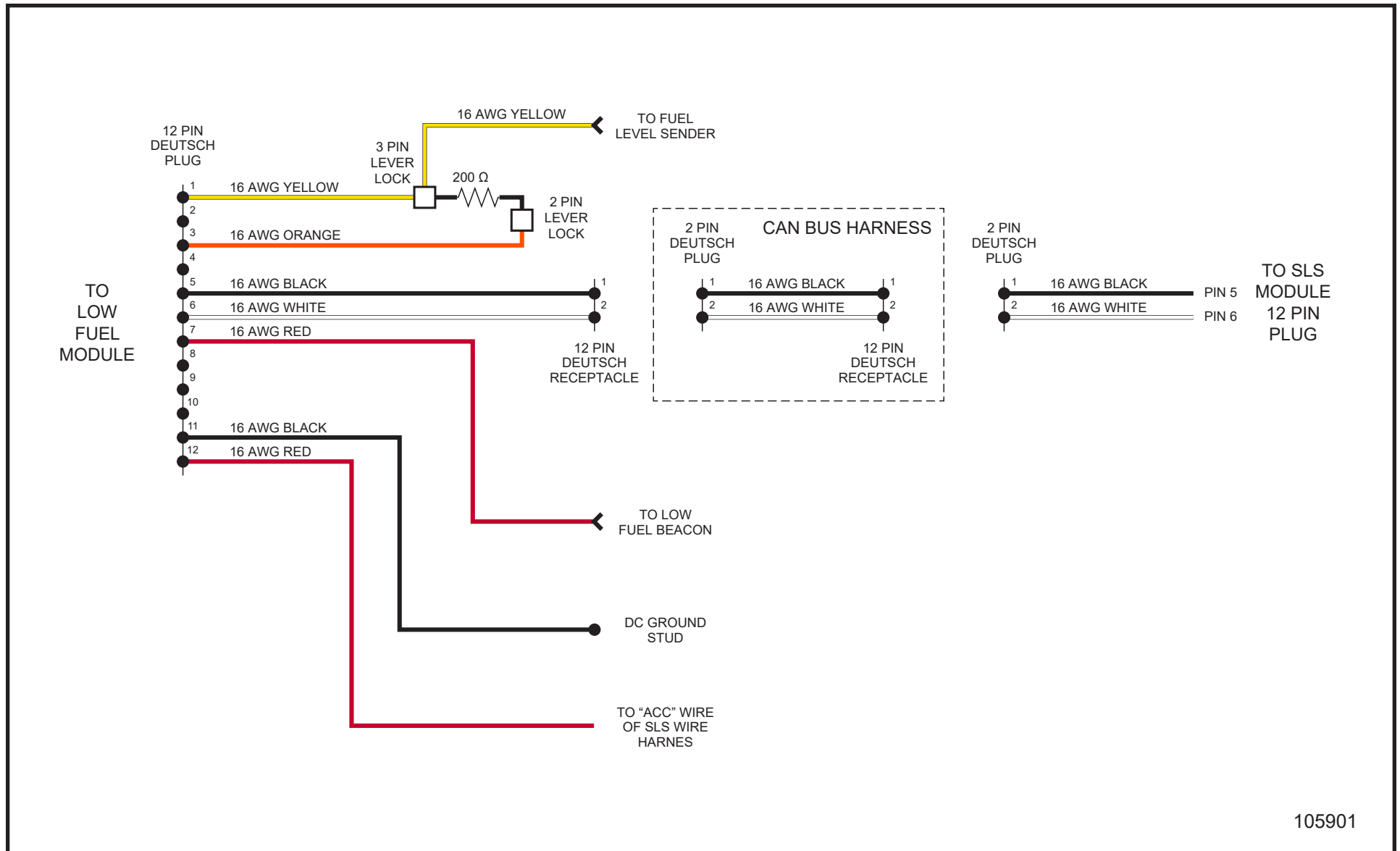

105901

Maxi-Lite

1.16 - Low Fuel Sender Schematic

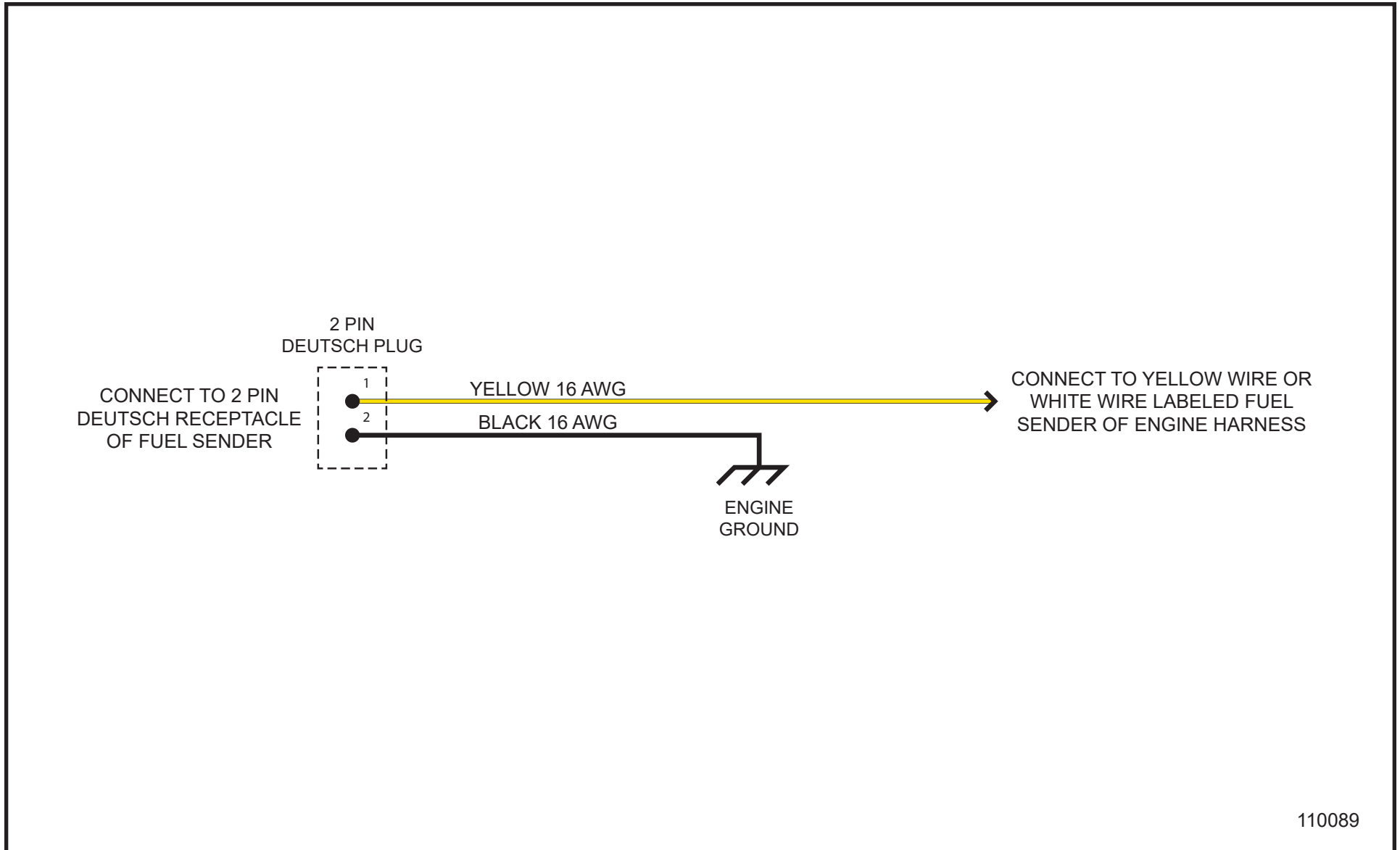

1.17 - 2-GFCI, 2-30A Twistlock, 1-30A RV 8kW Outlet Schematic

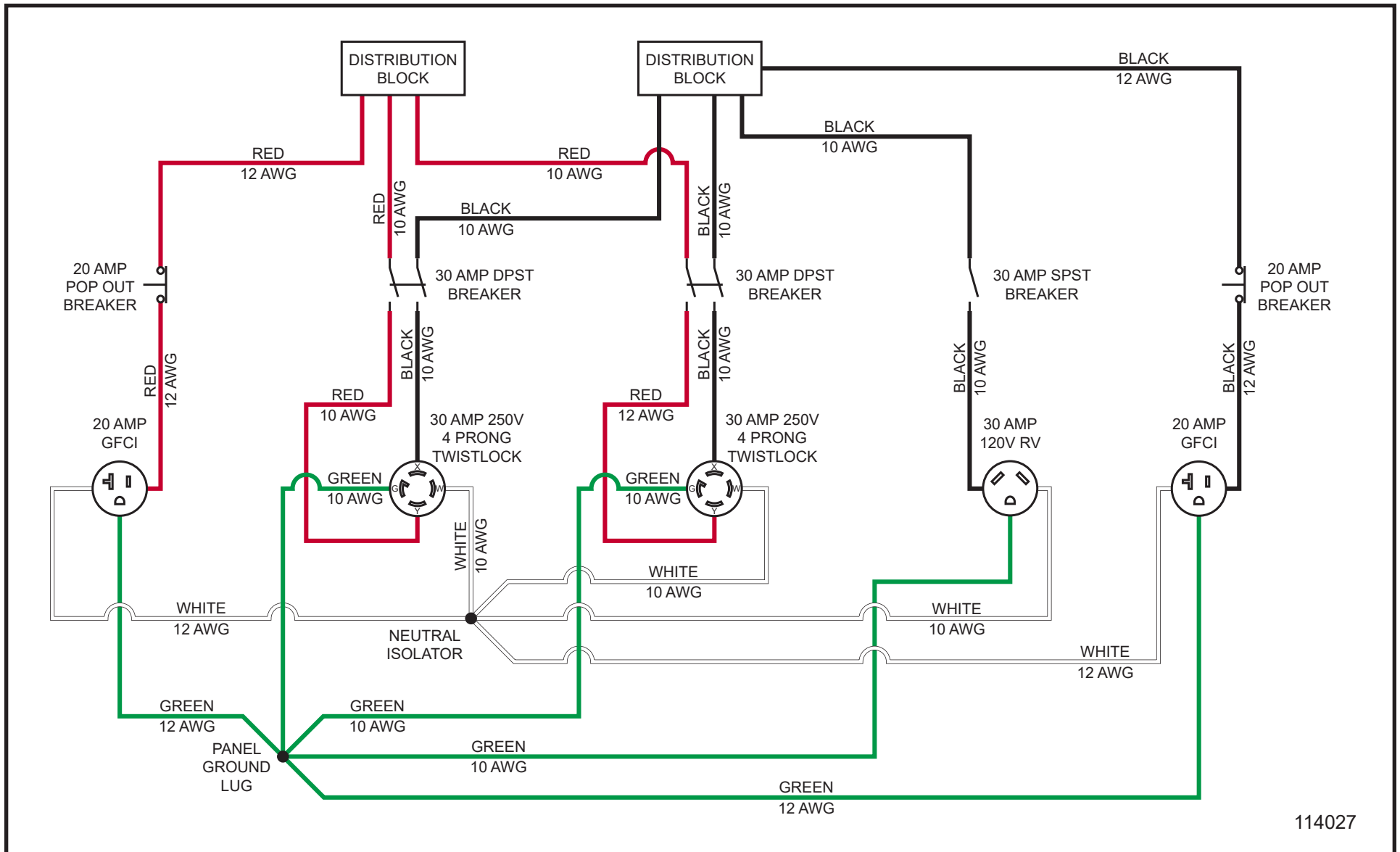

114027

Maxi-Lite

1.18 - 2-GFCI, 4-30A Twistlock 15/20kW Outlet Schematic

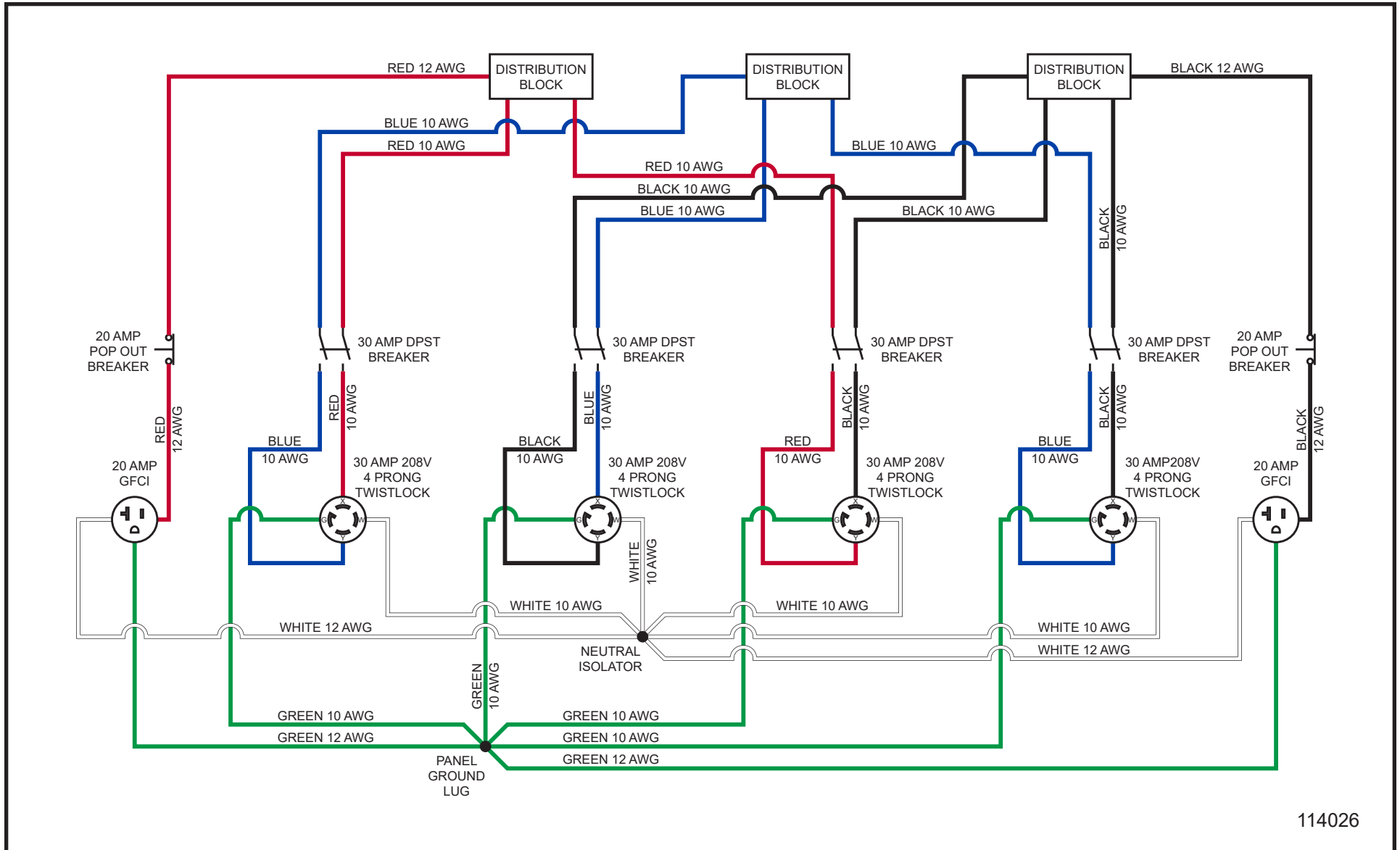

114026

Maxi-Lite

1.20 - 2-GFCI, 2-30A RV, 2-50A RV 15/20kW Outlet Schematic

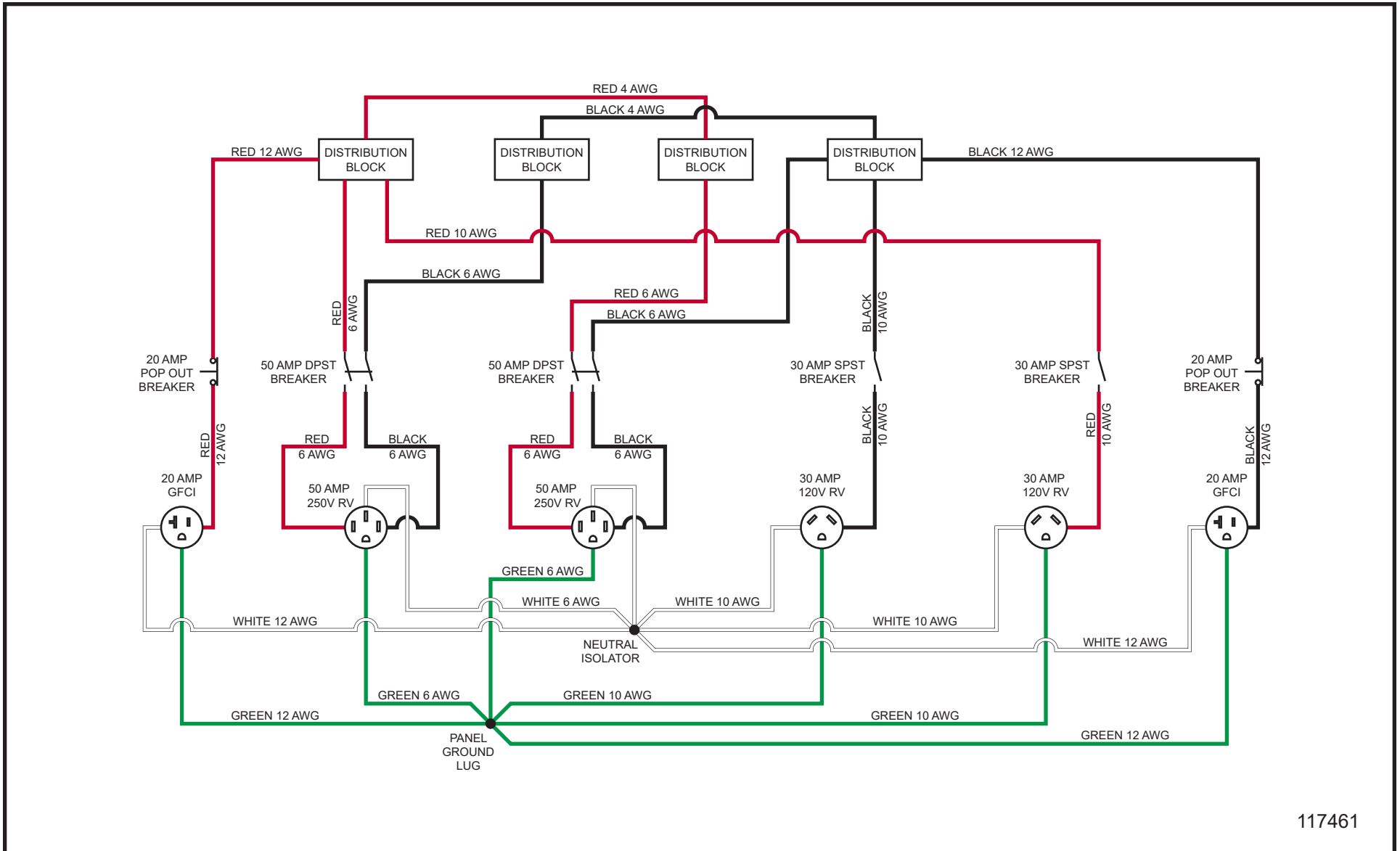

117461

1.21 - 2-GFCI, 3-30A Twistlock, 1-50A Twistlock 15/20kW Outlet Schematic

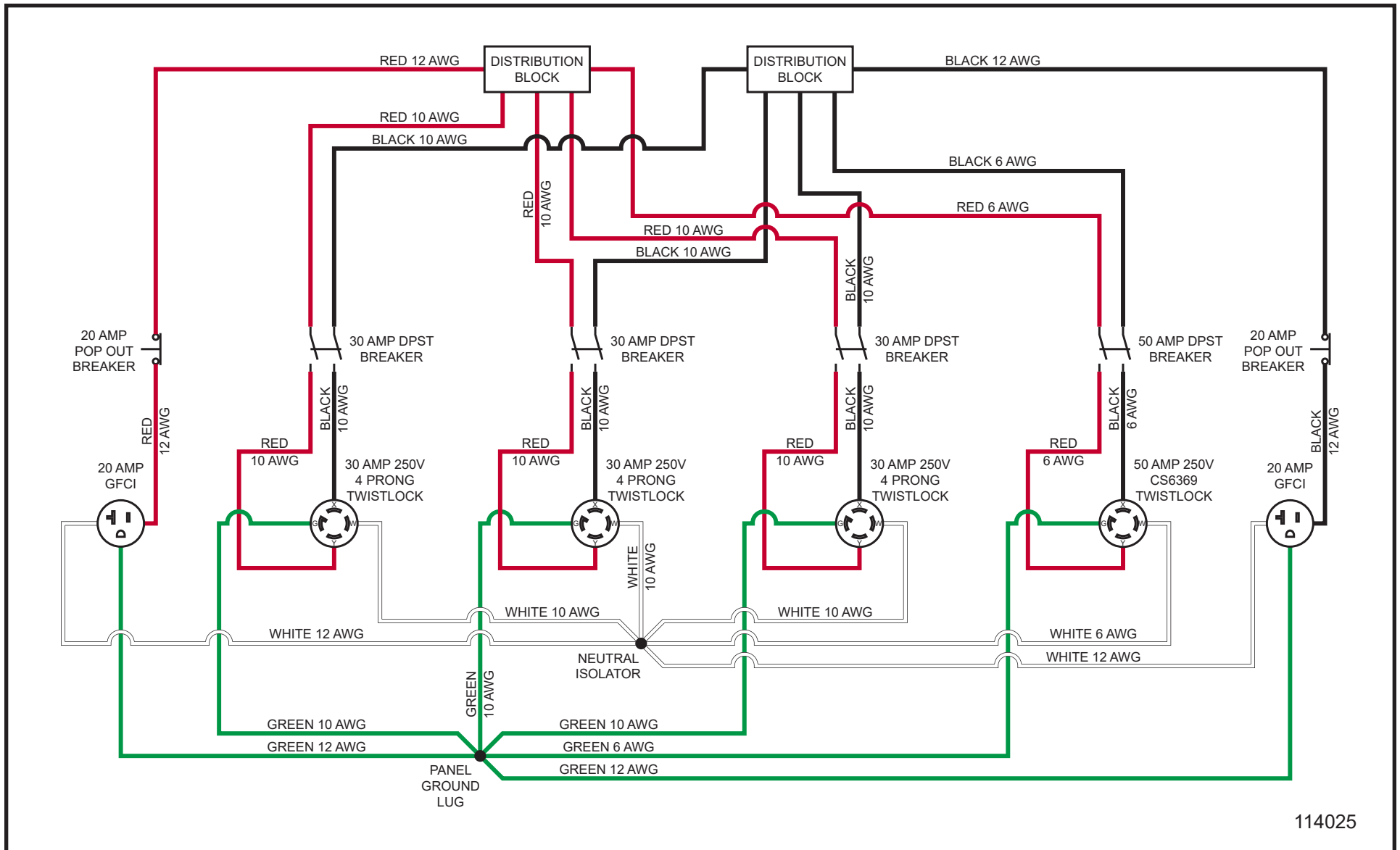

114025

Maxi-Lite

1.22 - 60A 3P Auxiliary Outlet Schematic

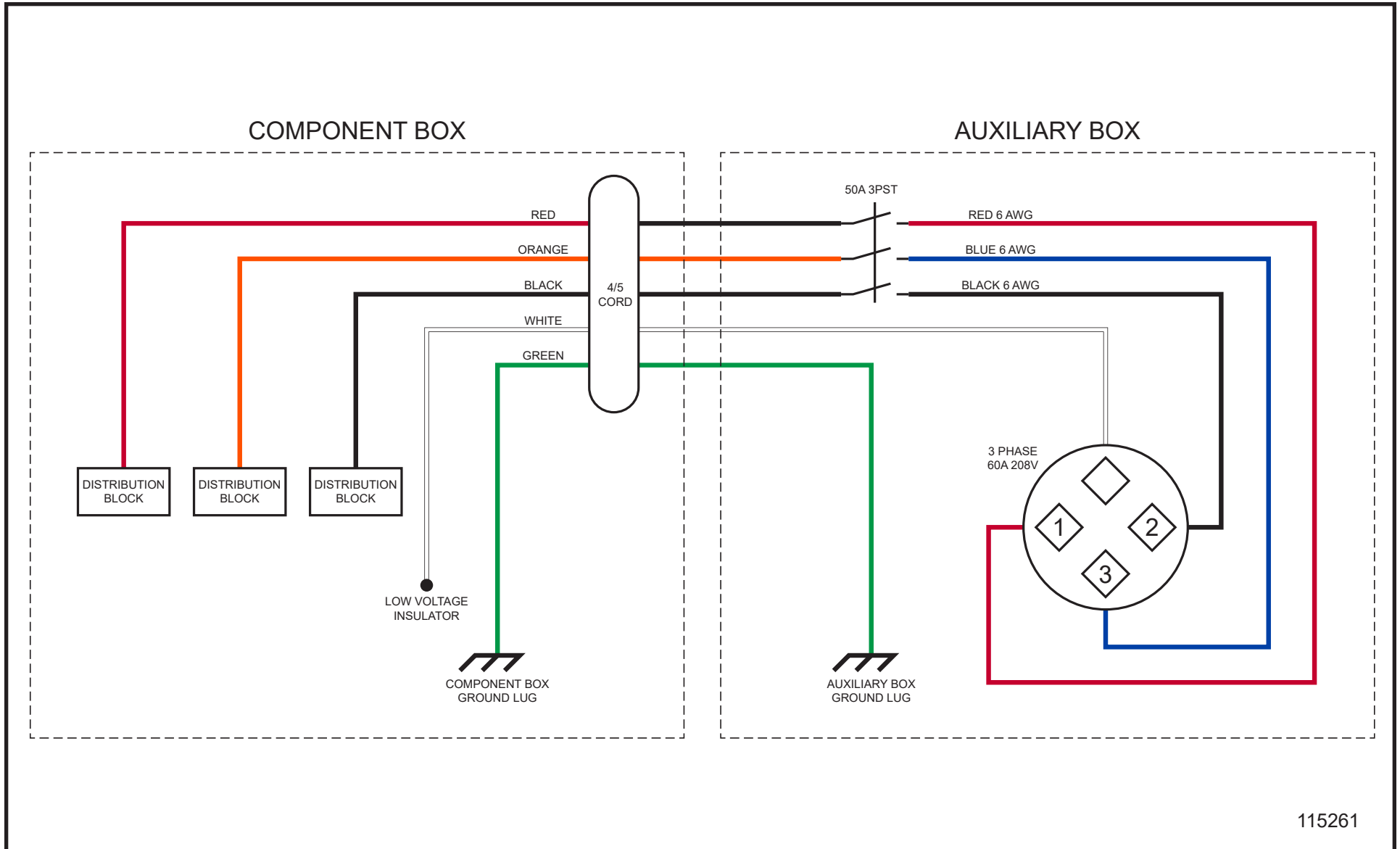

115261

1.23 - 4-Light 1P Relay Schematic

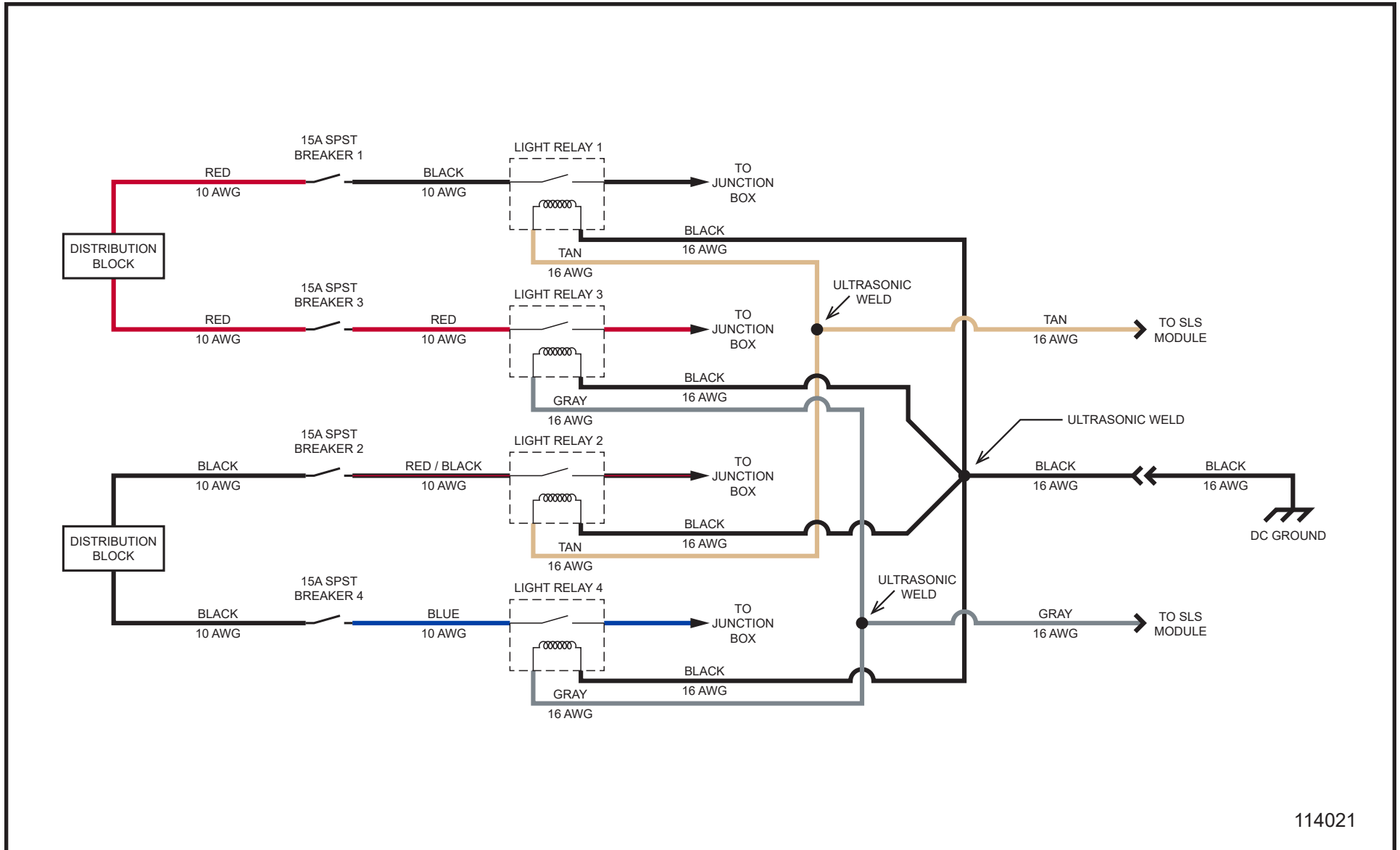

114021

Maxi-Lite

1.24 - 4-Light 3P Relay Schematic

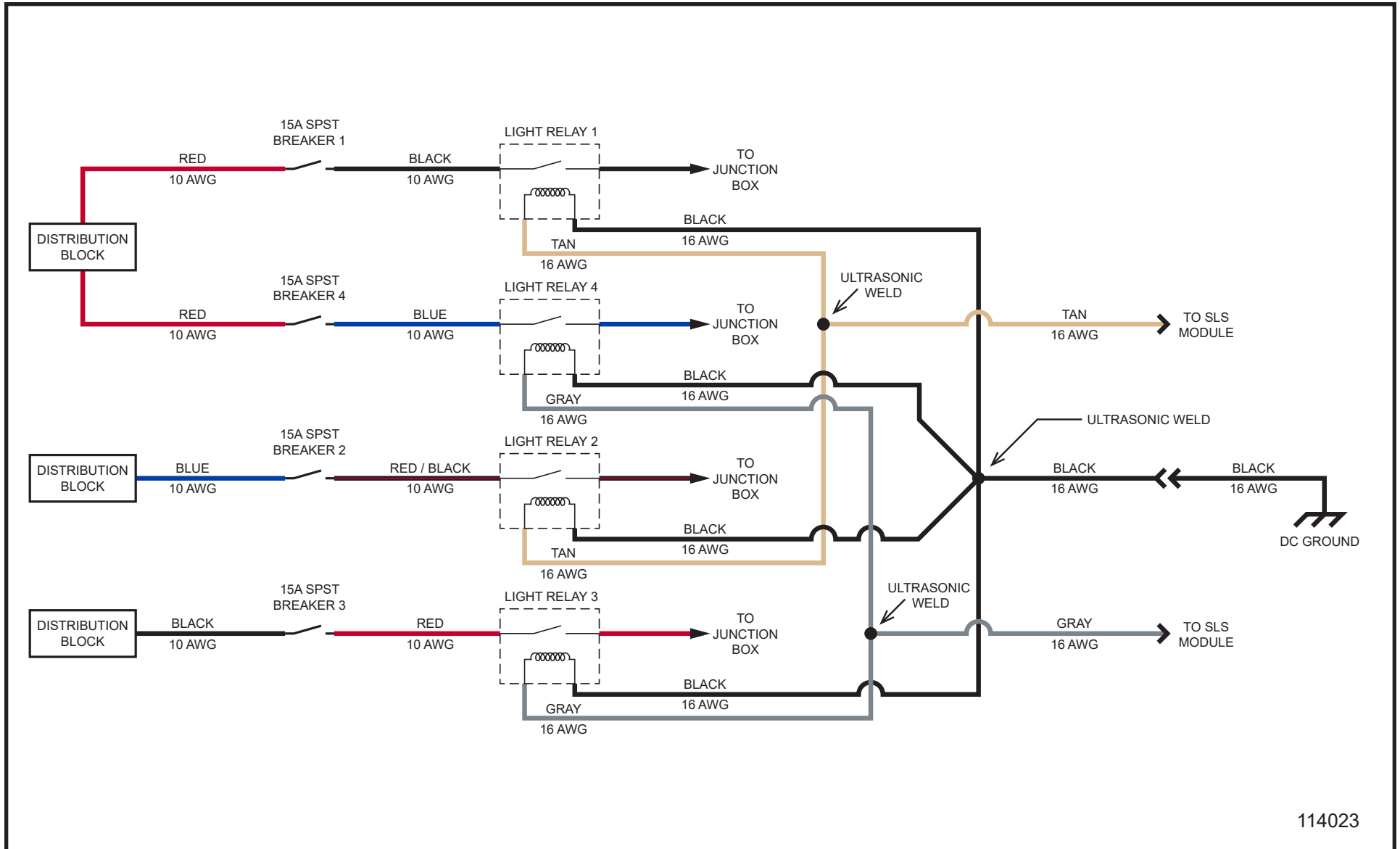

114023

1.25 - 6-Light 1P Relay Schematic

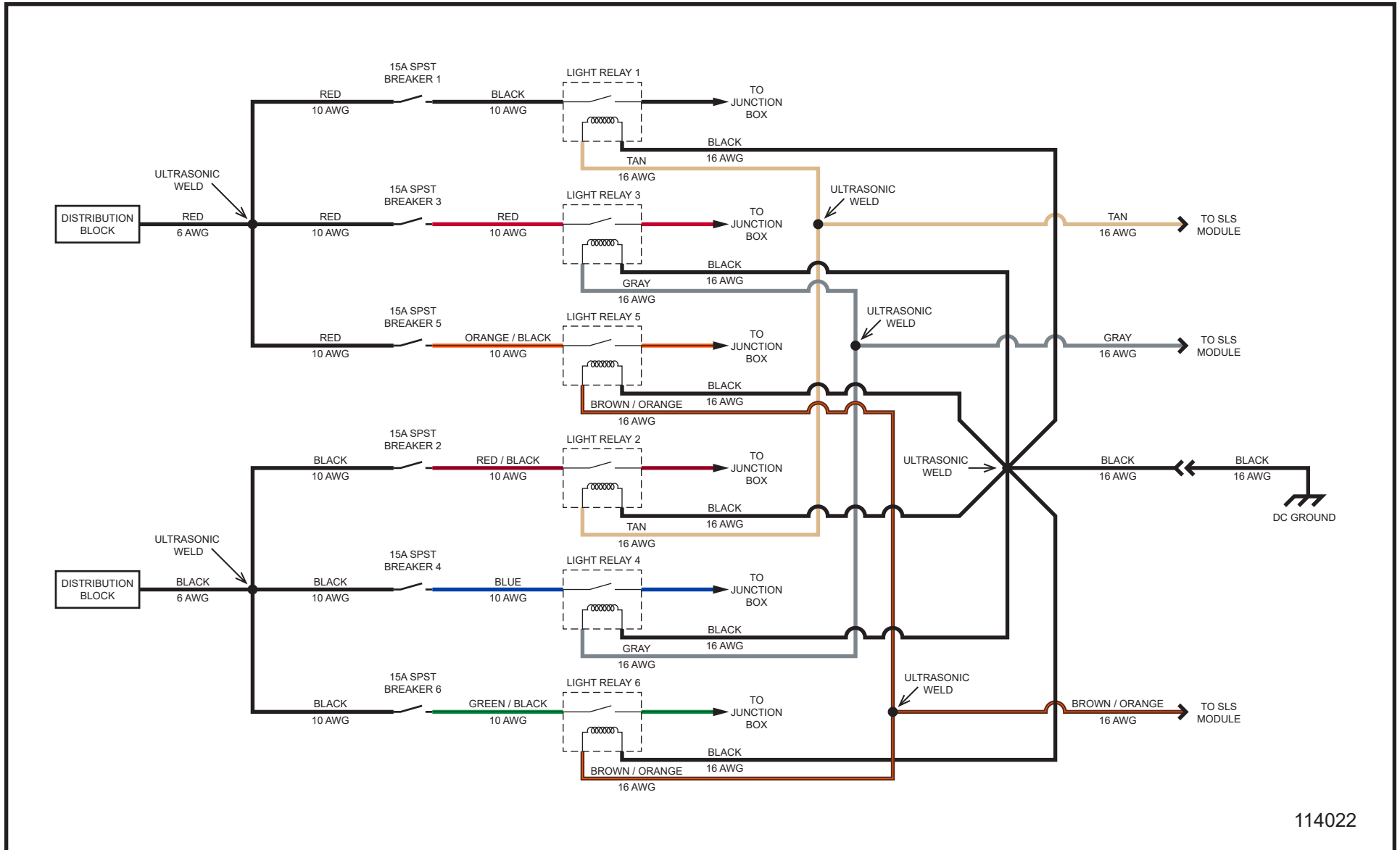

114022

Maxi-Lite

1.26 - 6-Light 1P Relay Schematic

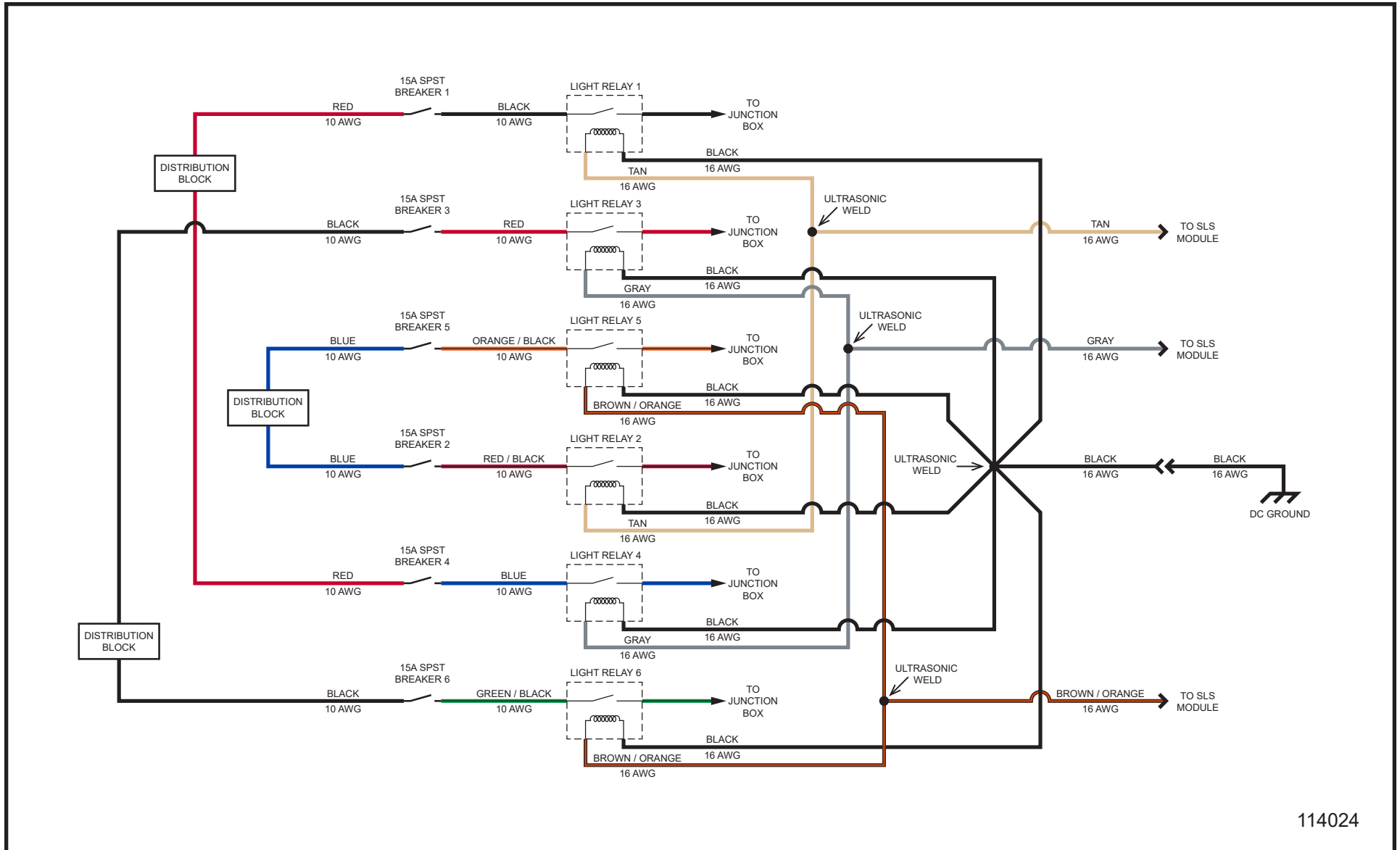

114024

1.27 - 4-Light SHO 16/8 Cord Junction Box Schematic

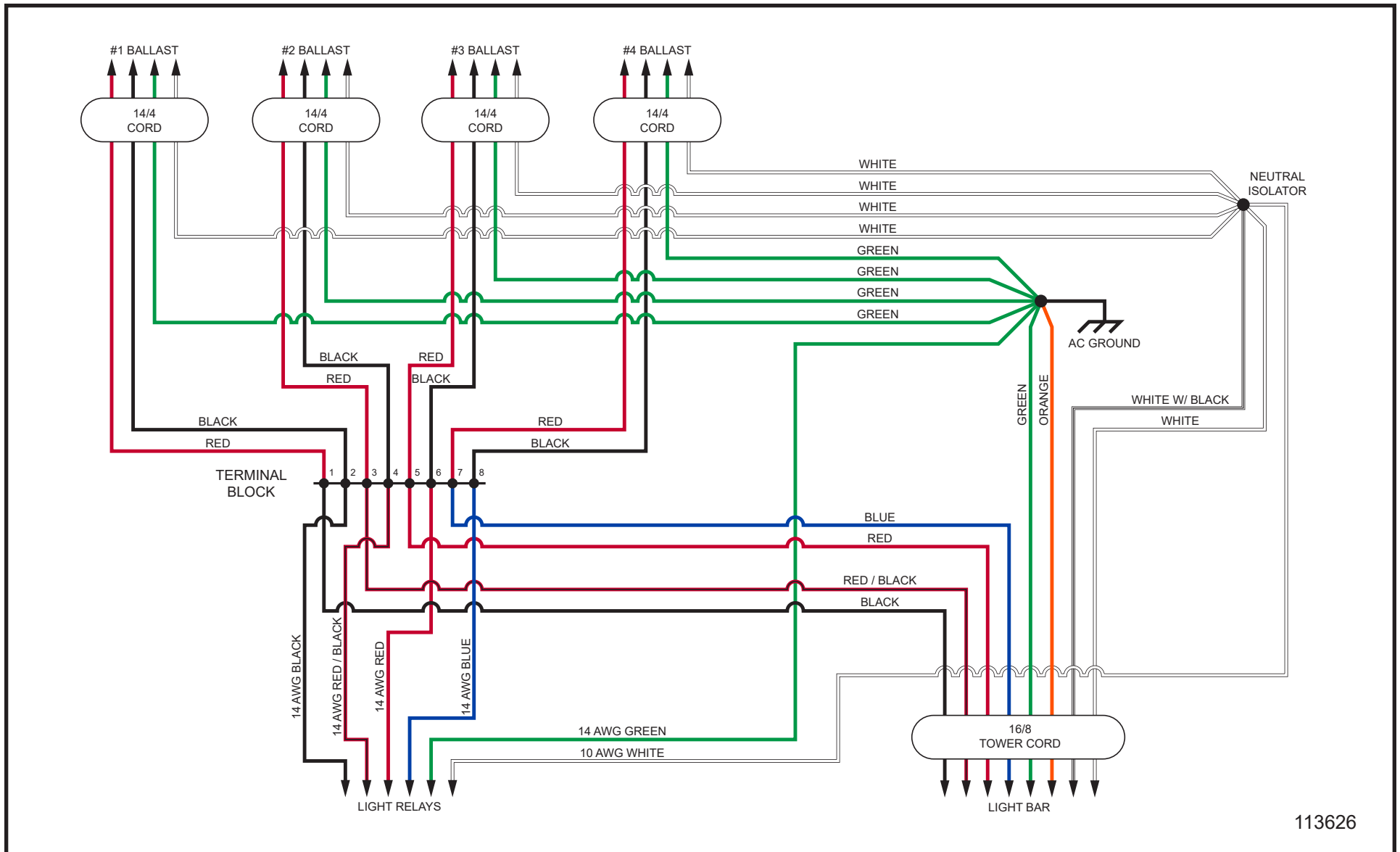

113626

Maxi-Lite

1.28 - 6-Light SHO 16/10 Cord Junction Box Schematic

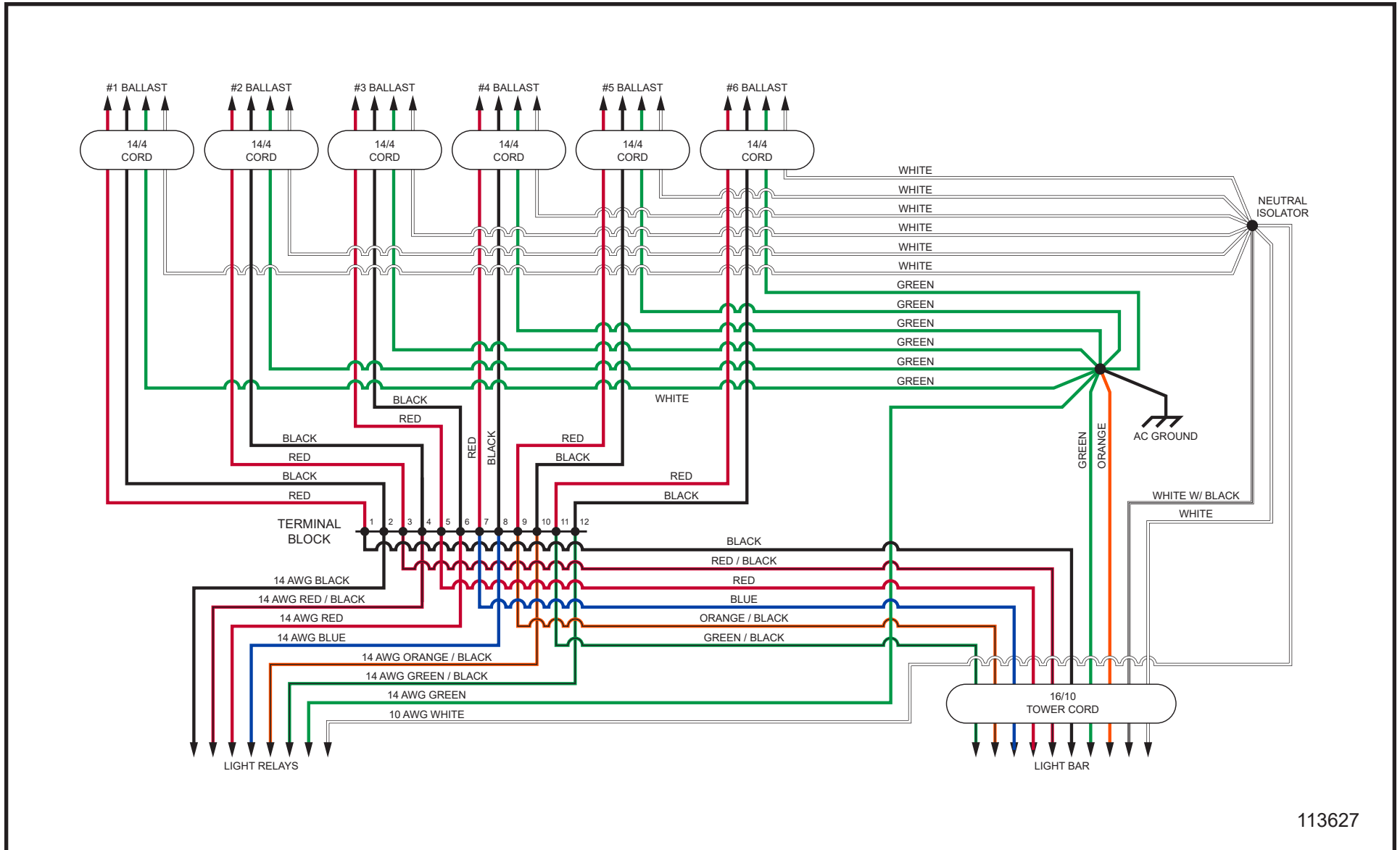

113627

1.29 - 4-Light LED 16/8 Cord Junction Box Schematic

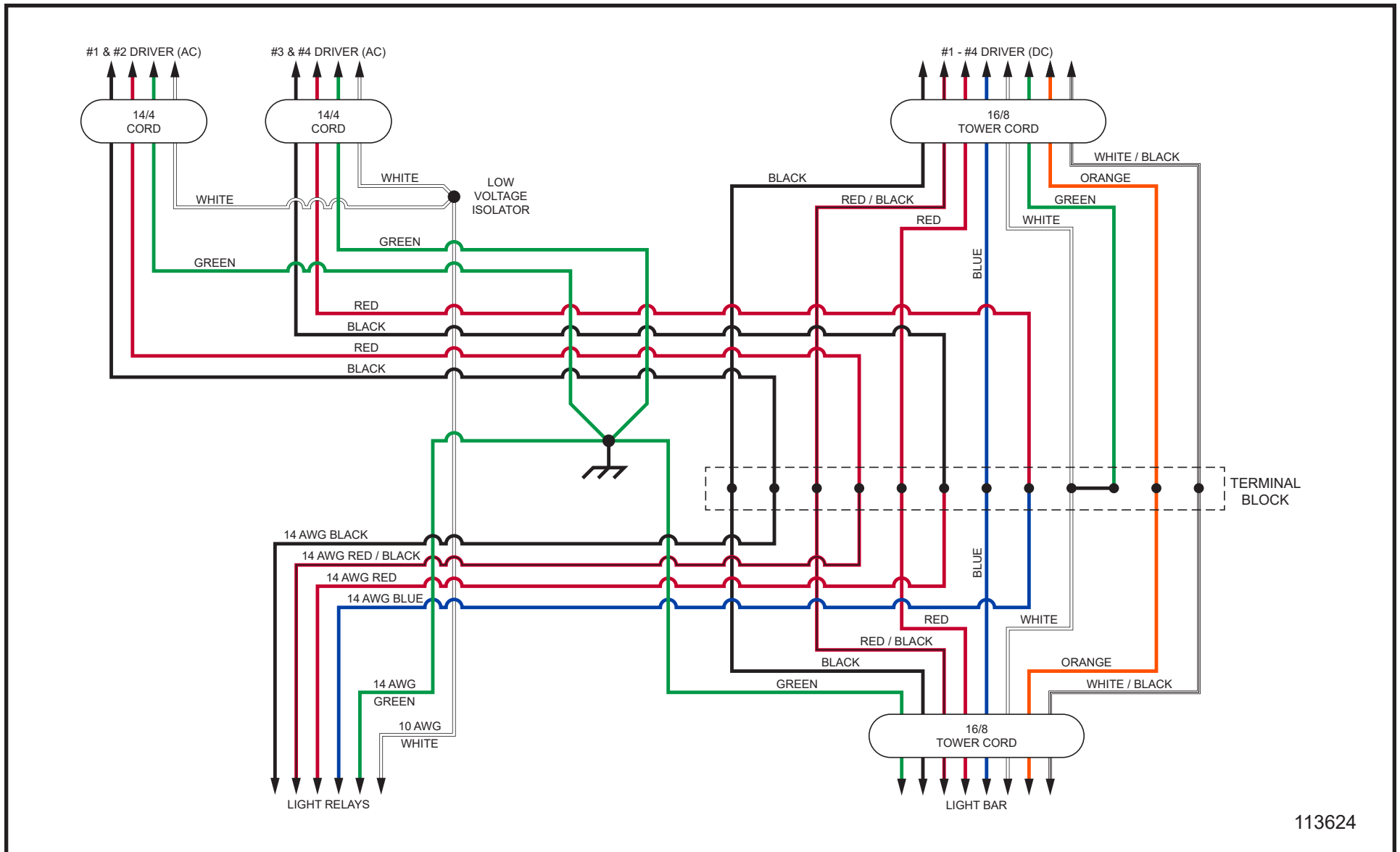

113624

Maxi-Lite

1.30 - 6-Light LED 16/14 Cord Junction Box Schematic

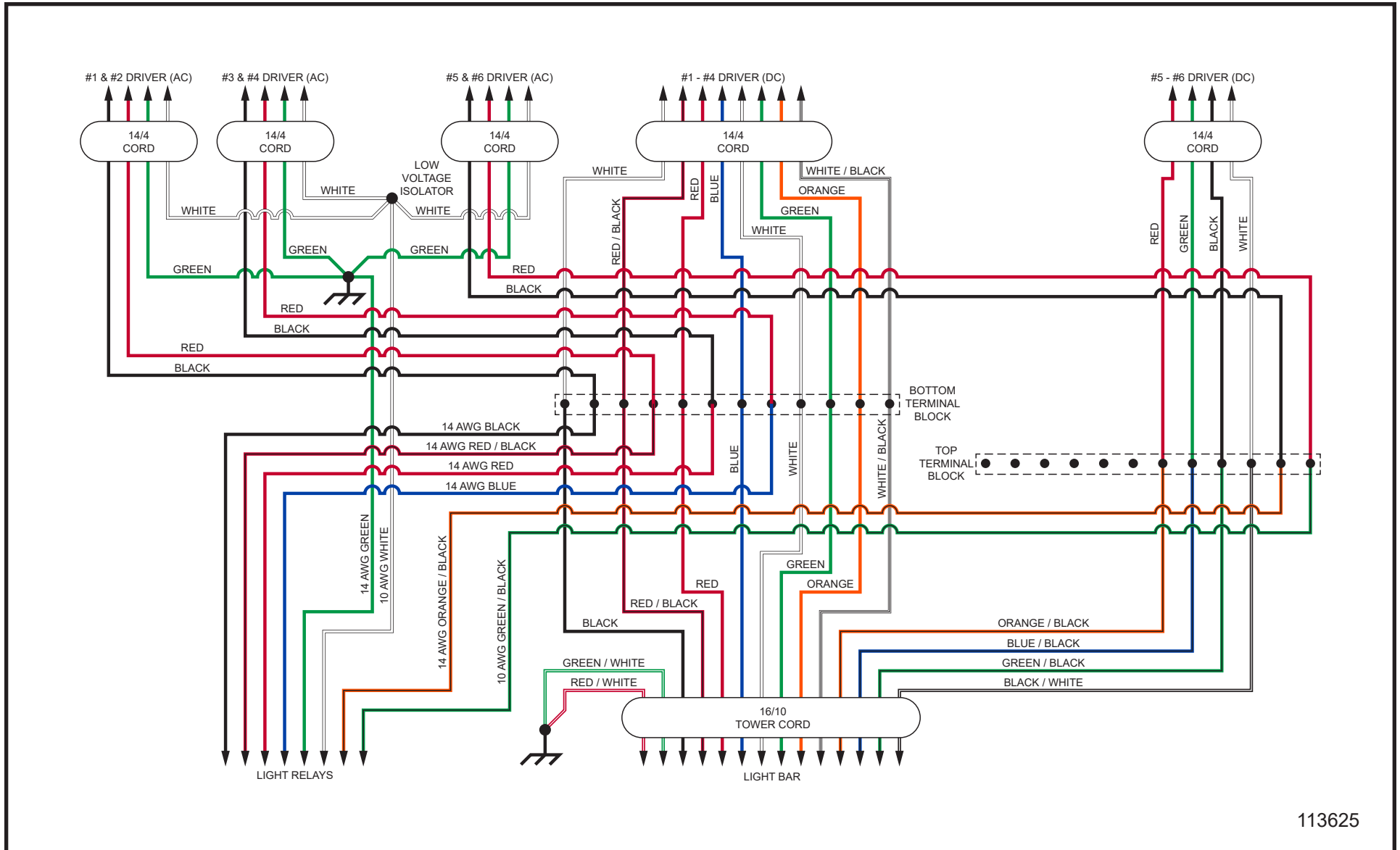

113625

1.31 - 1000W 60Hz 120V Ballast Schematic

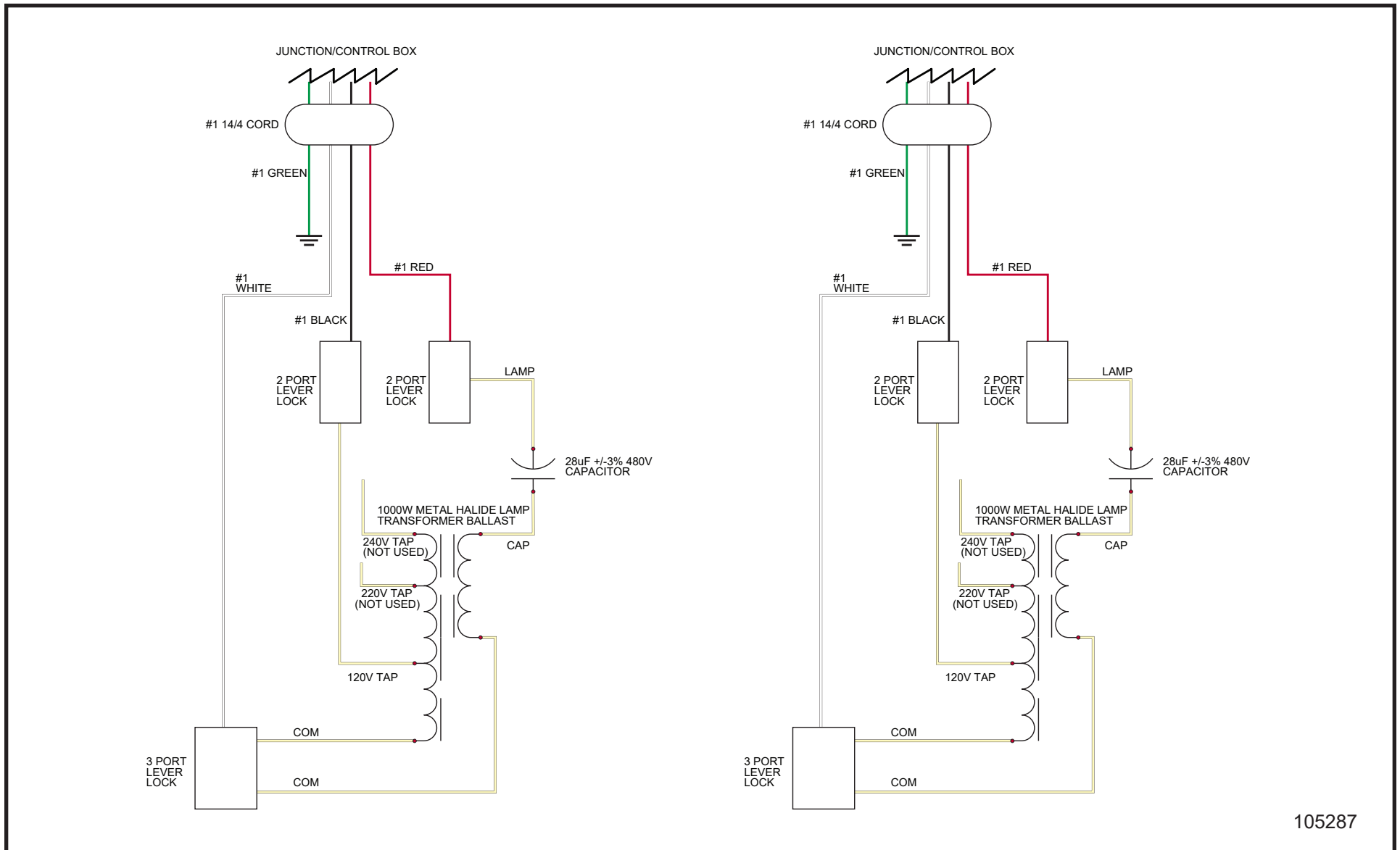

105287

Maxi-Lite

1.32 - 1000W 60Hz 120V HPS Ballast Schematic

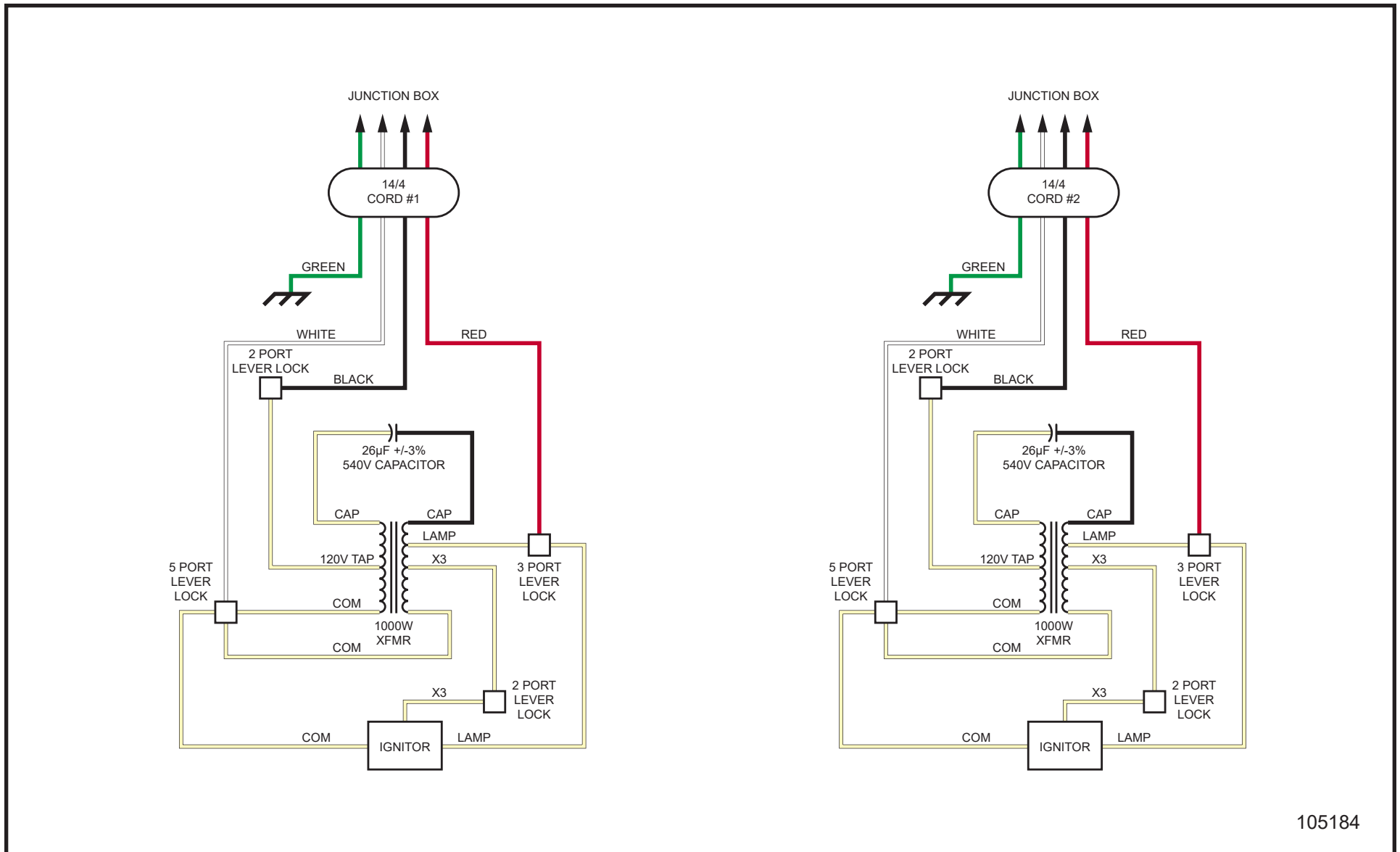

1.33 - 1000W 50Hz 120V Ballast Schematic

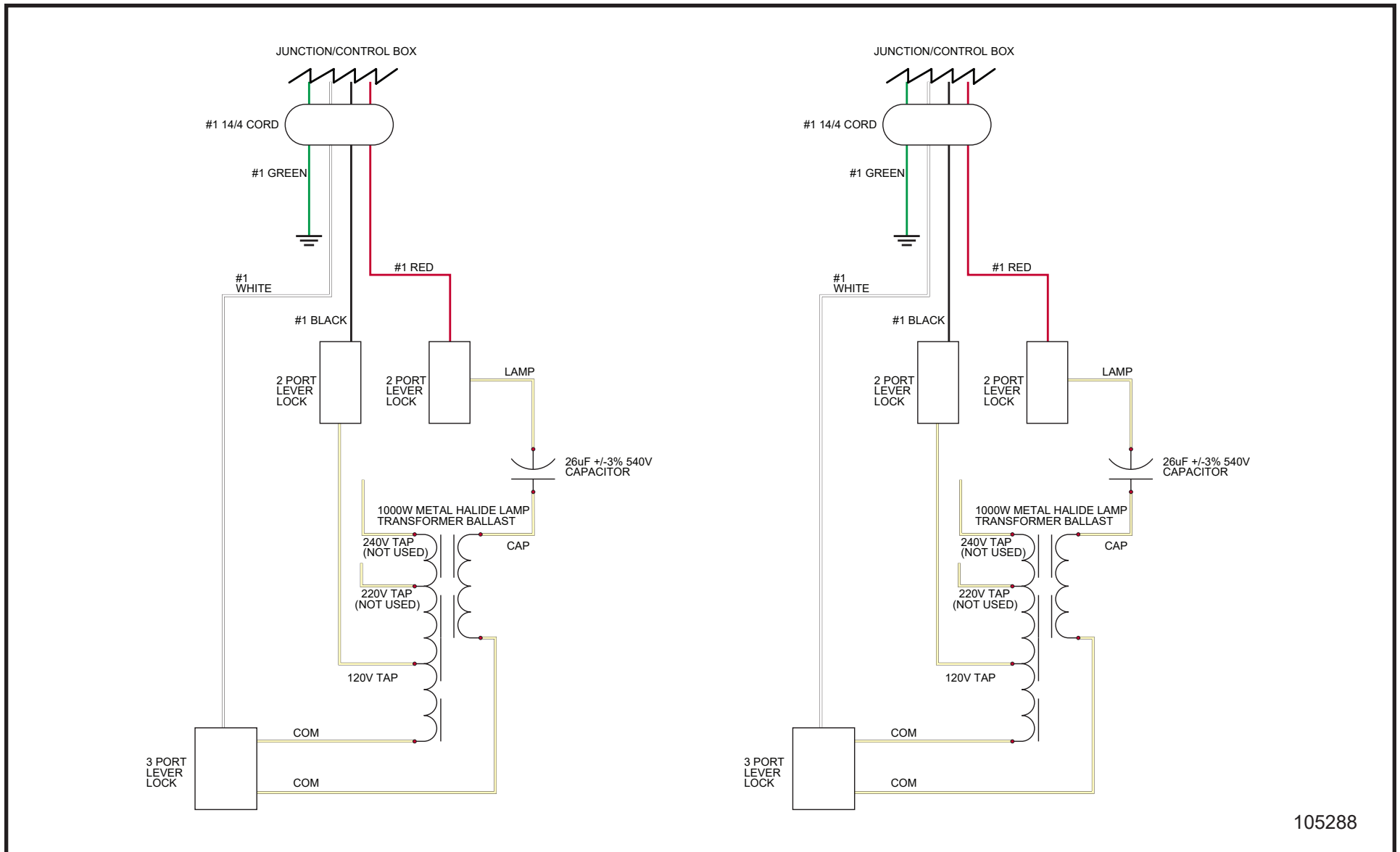

105288

Maxi-Lite

1.34 - 1000W 50Hz 220V HPS Ballast Schematic

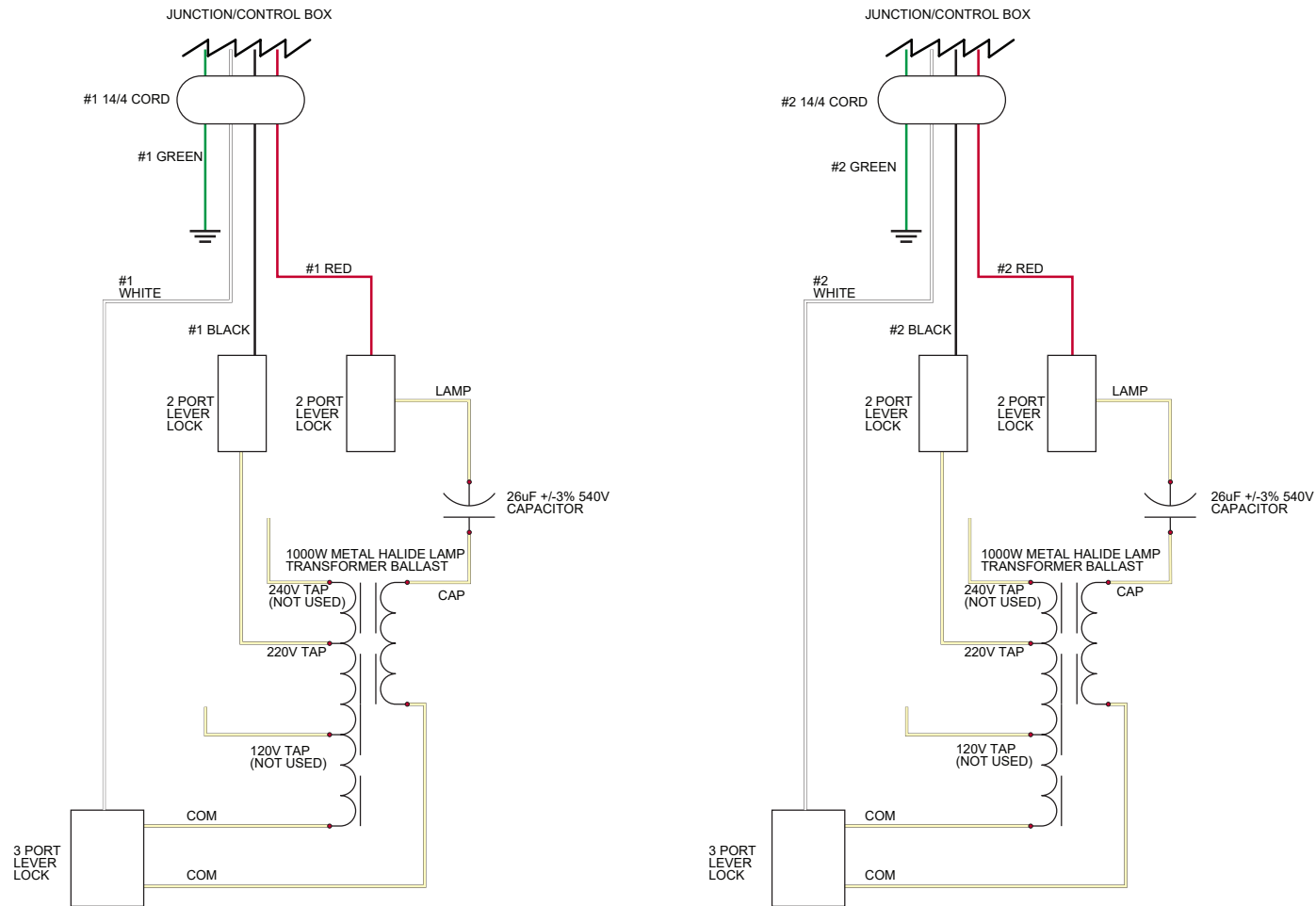

105289

1.35 - 1250W 60Hz 120V Ballast Schematic

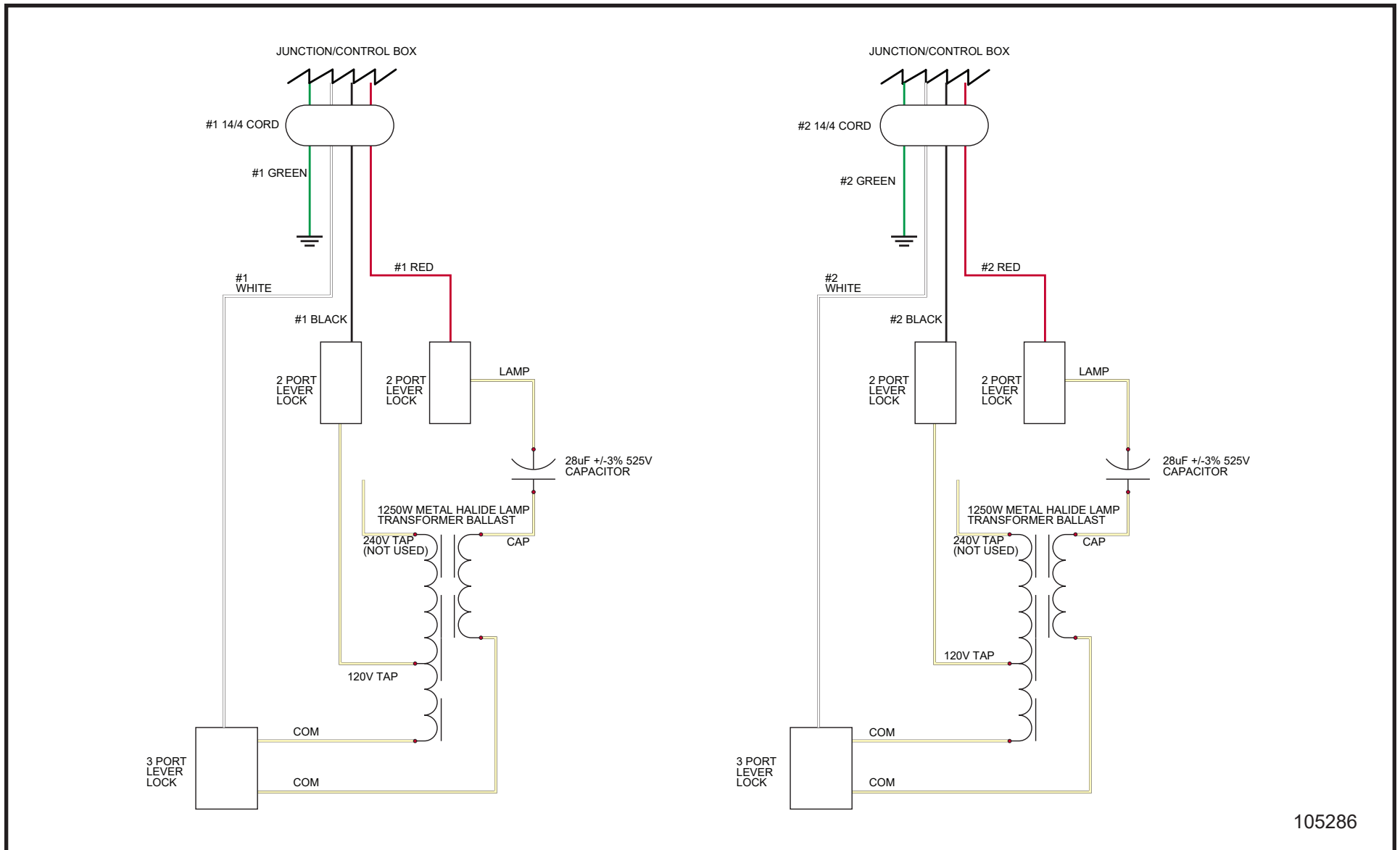

105286

Maxi-Lite

1.36 - 1-4 LED Drivers Schematic

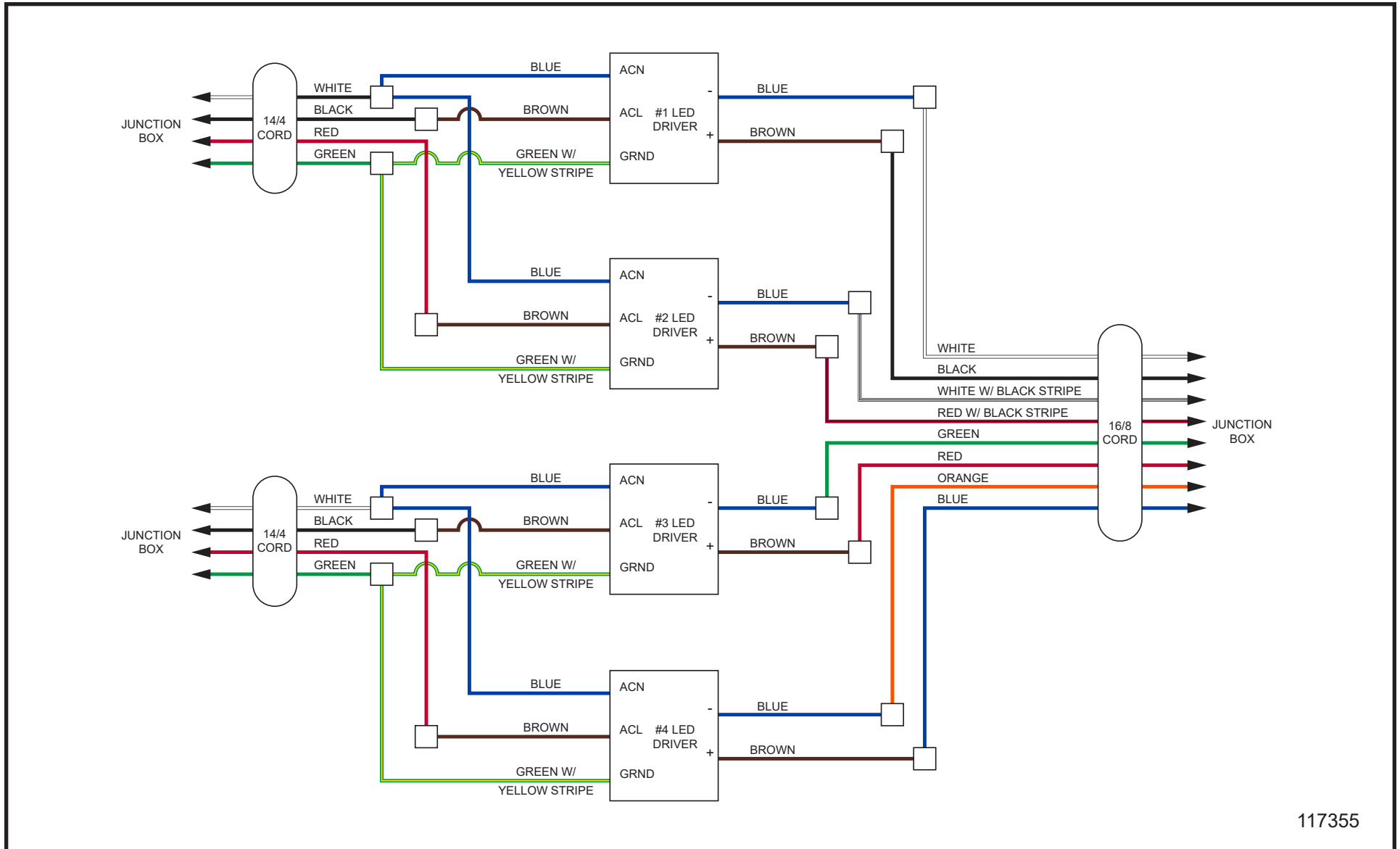

117355

1.37 - 5-6 LED Drivers Schematic

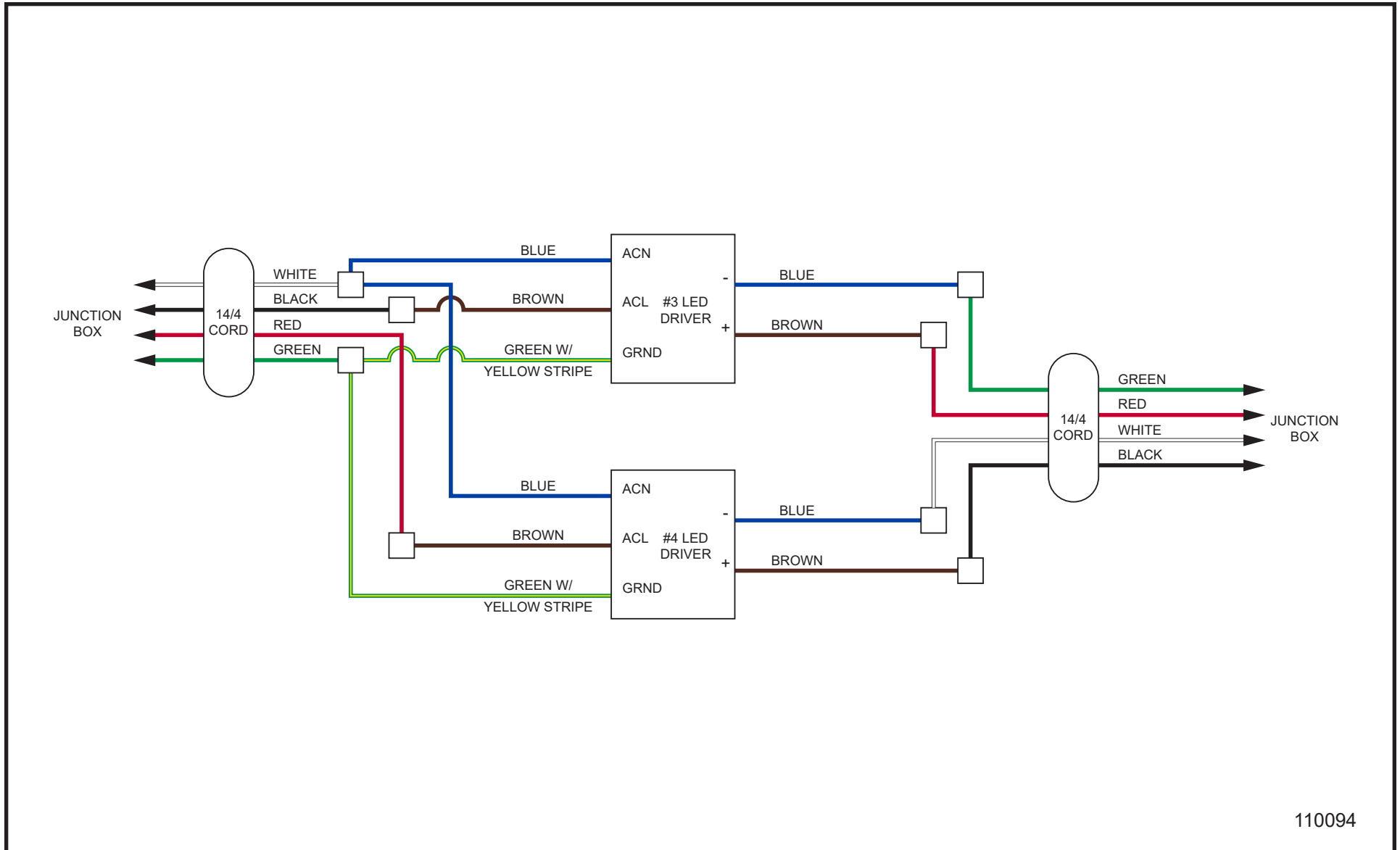

110094

Maxi-Lite

1.38 - 4-Light SHO 16/8 Cord Light Bar Schematic

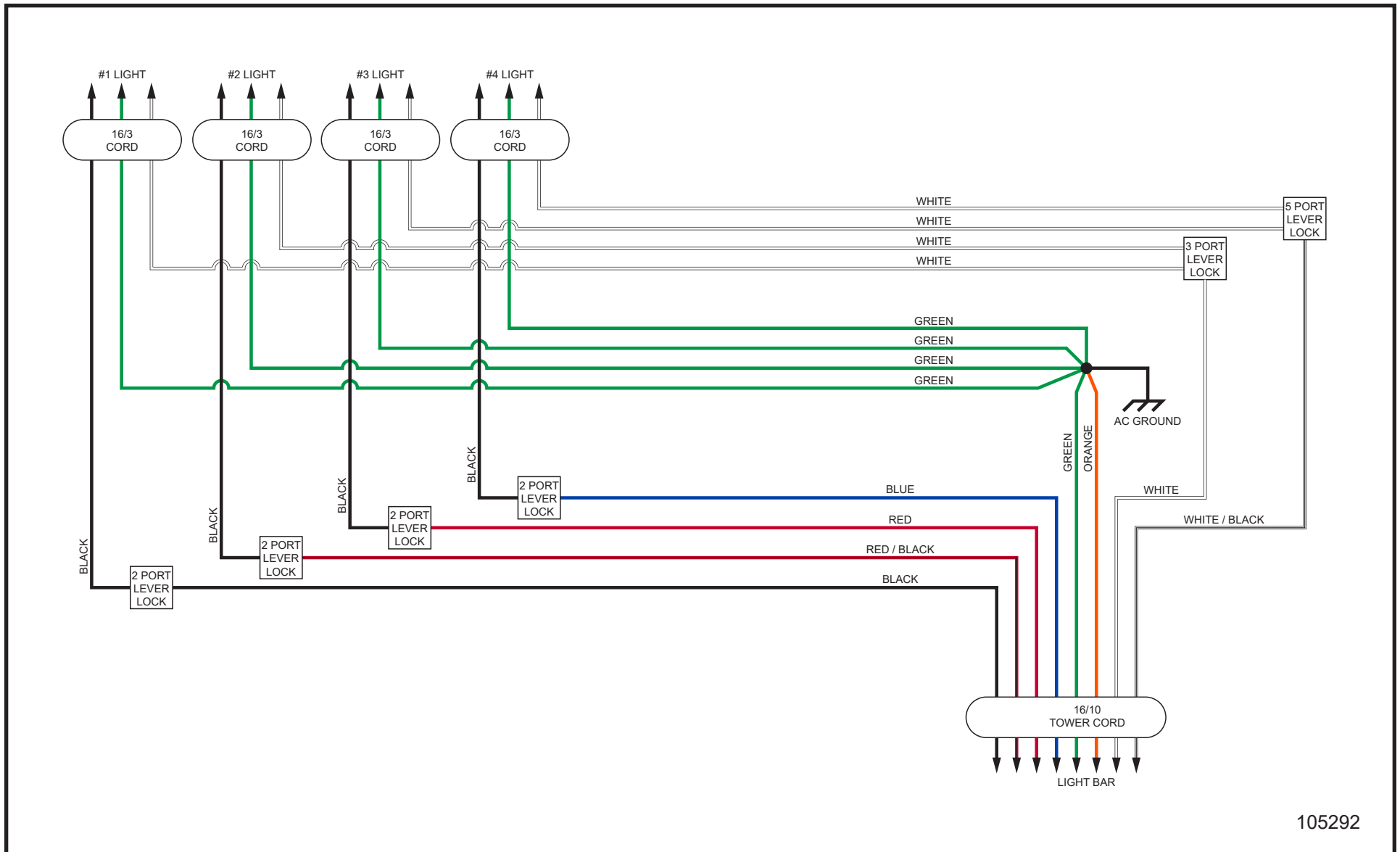

105292

1.39 - 6-Light SHO 16/10 Cord Light Bar Schematic

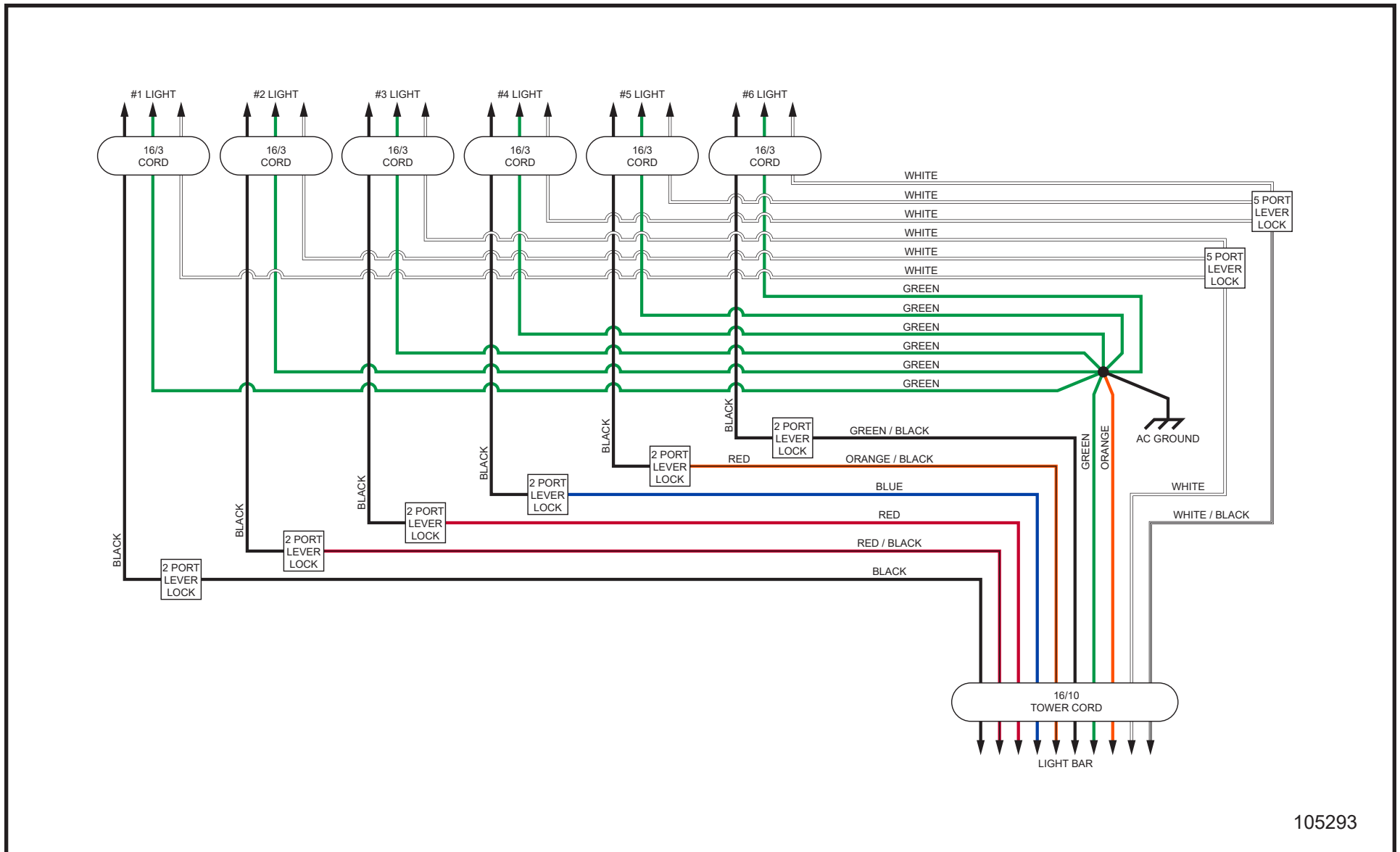

105293

Maxi-Lite

1.40 - 4-Light LED 16/8 Cord Light Bar Schematic

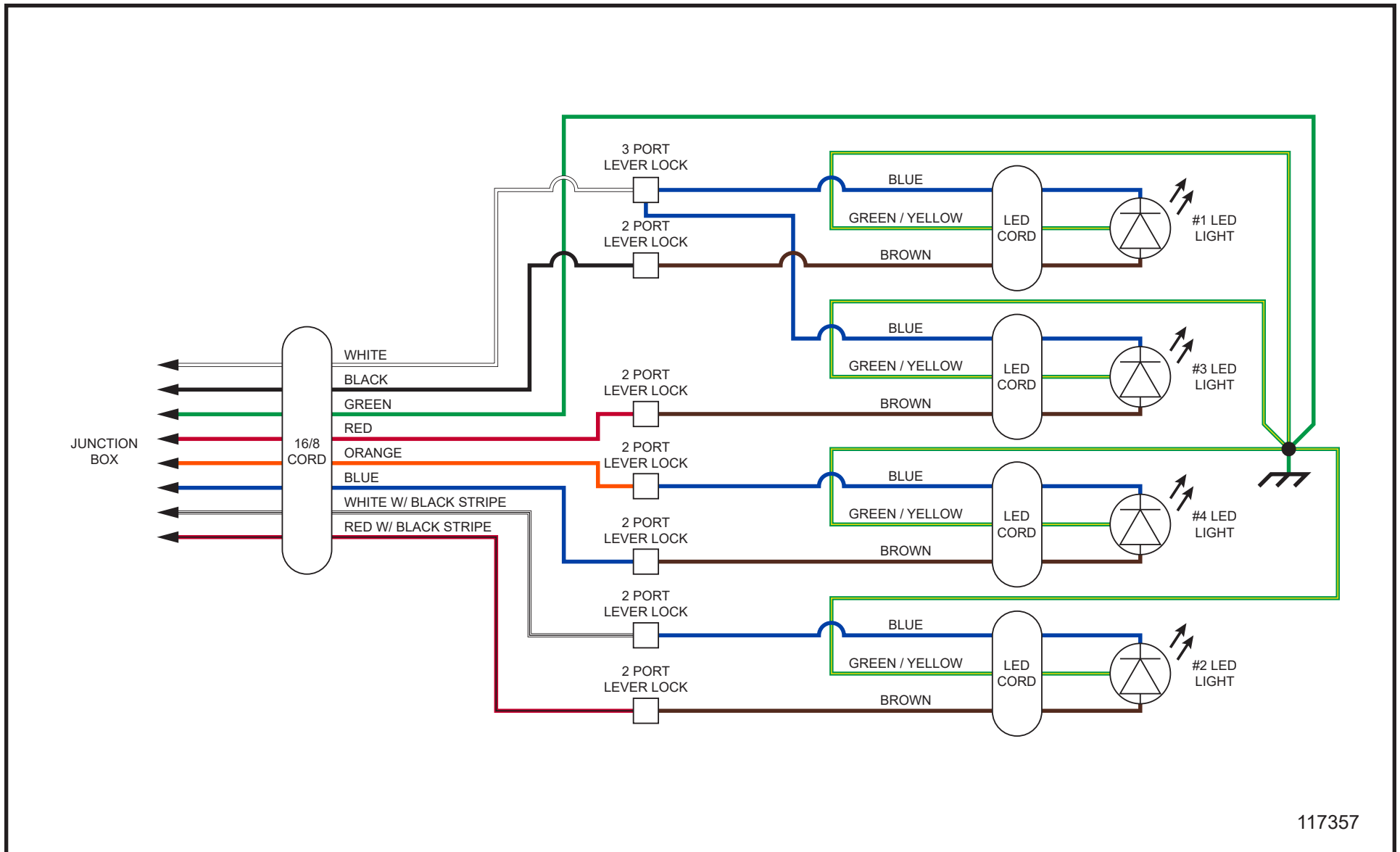

117357

1.41 - 6-Light LED 16/14 Cord Light Bar Schematic

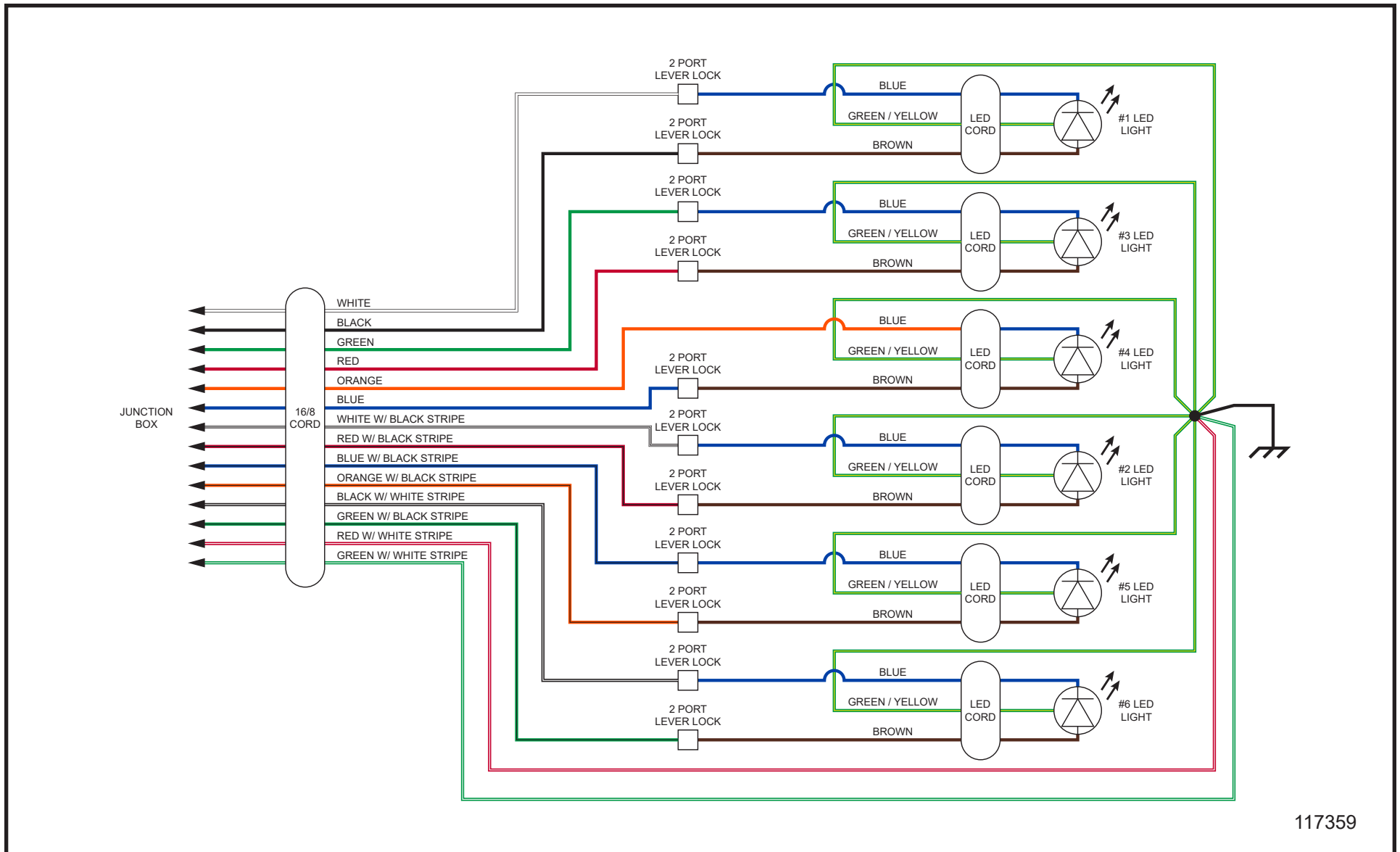

117359

Maxi-Lite

1.42 - Solid Wired SHO Lamp Schematic

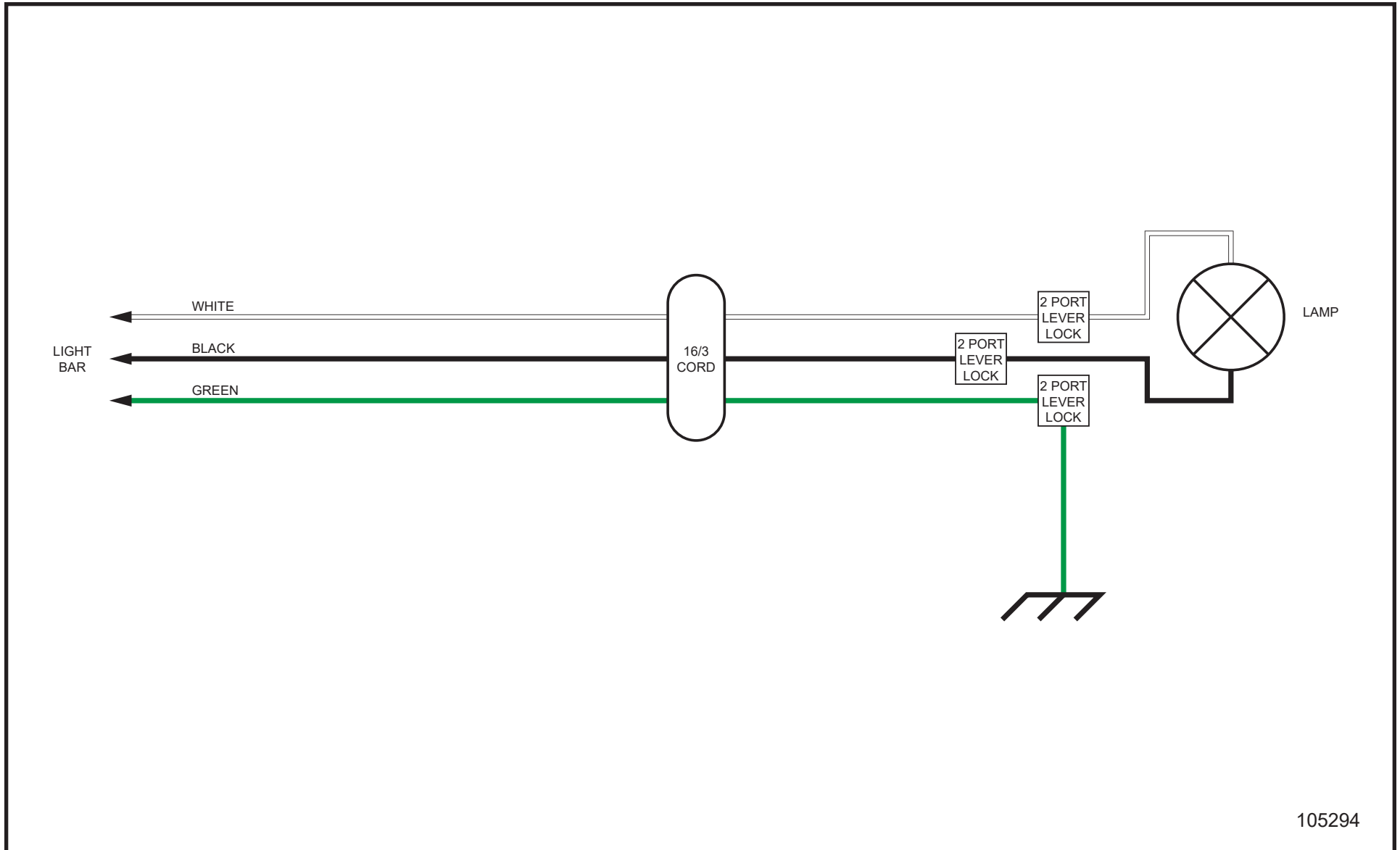

105294

1.43 - Quick Disconnect SHO Lamp Schematic

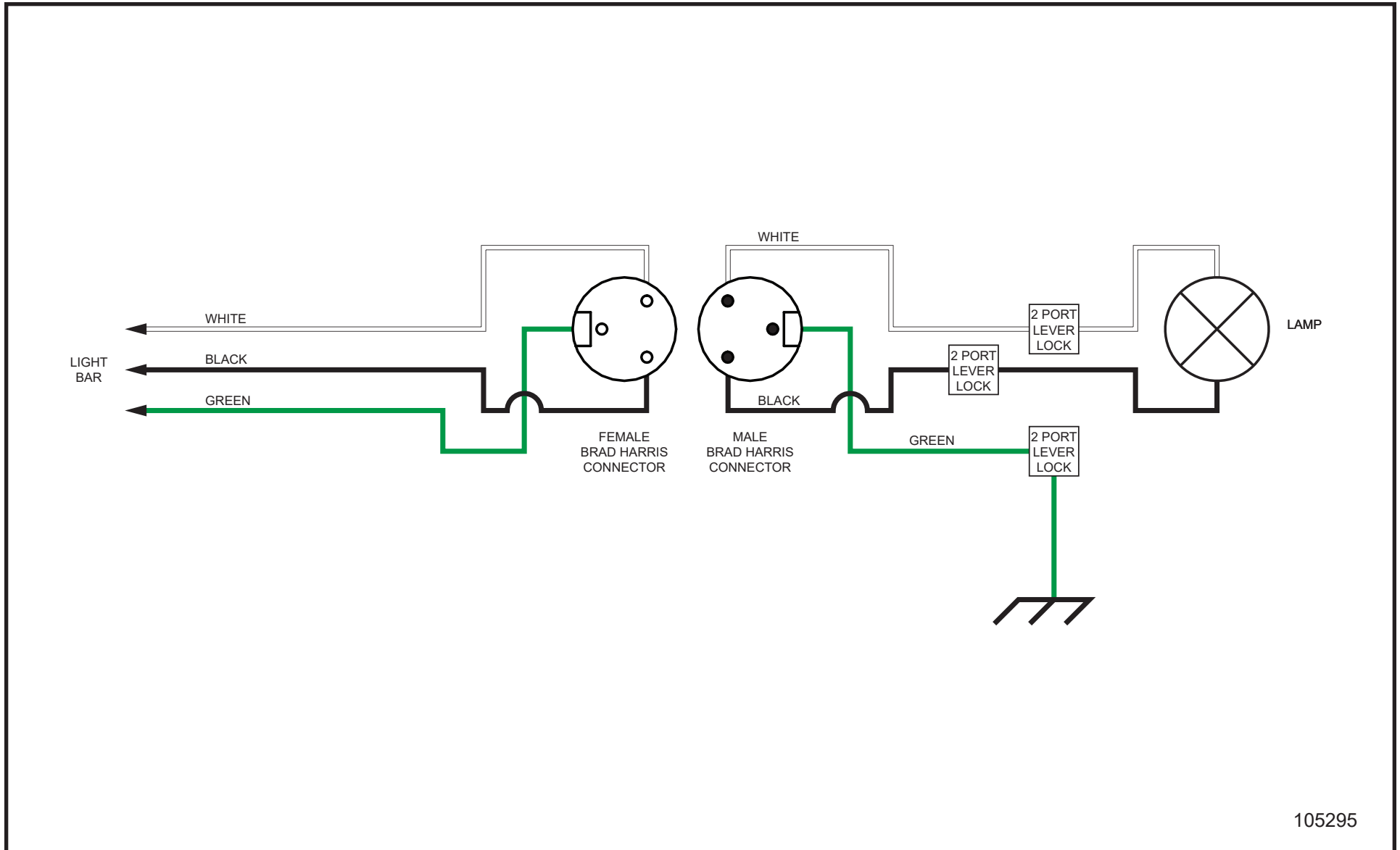

105295

Maxi-Lite

1.44 - Vertical Hydraulic Powered Schematic

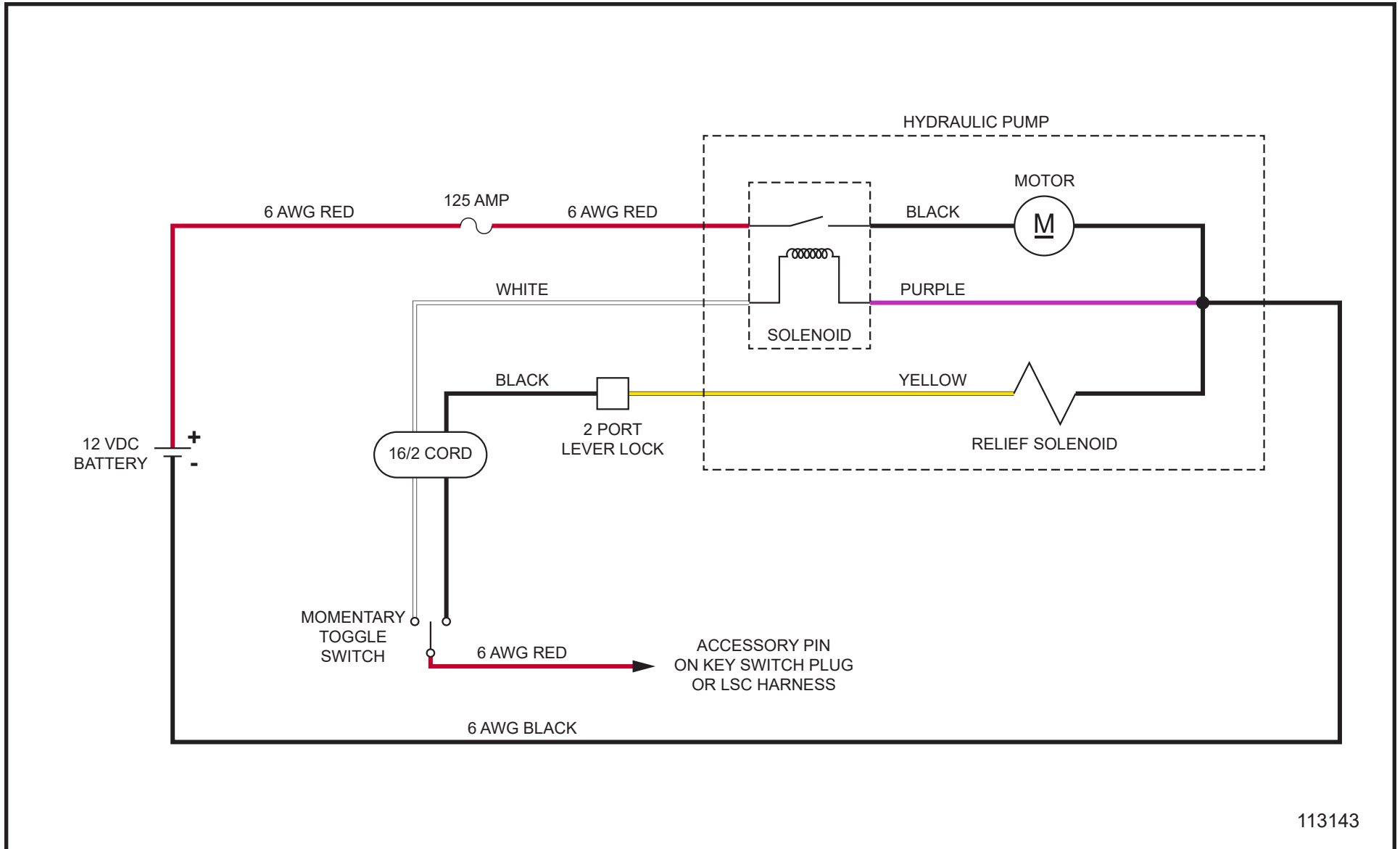

113143

1.45 - Isuzu Heated Fuel/Water Separator Schematic

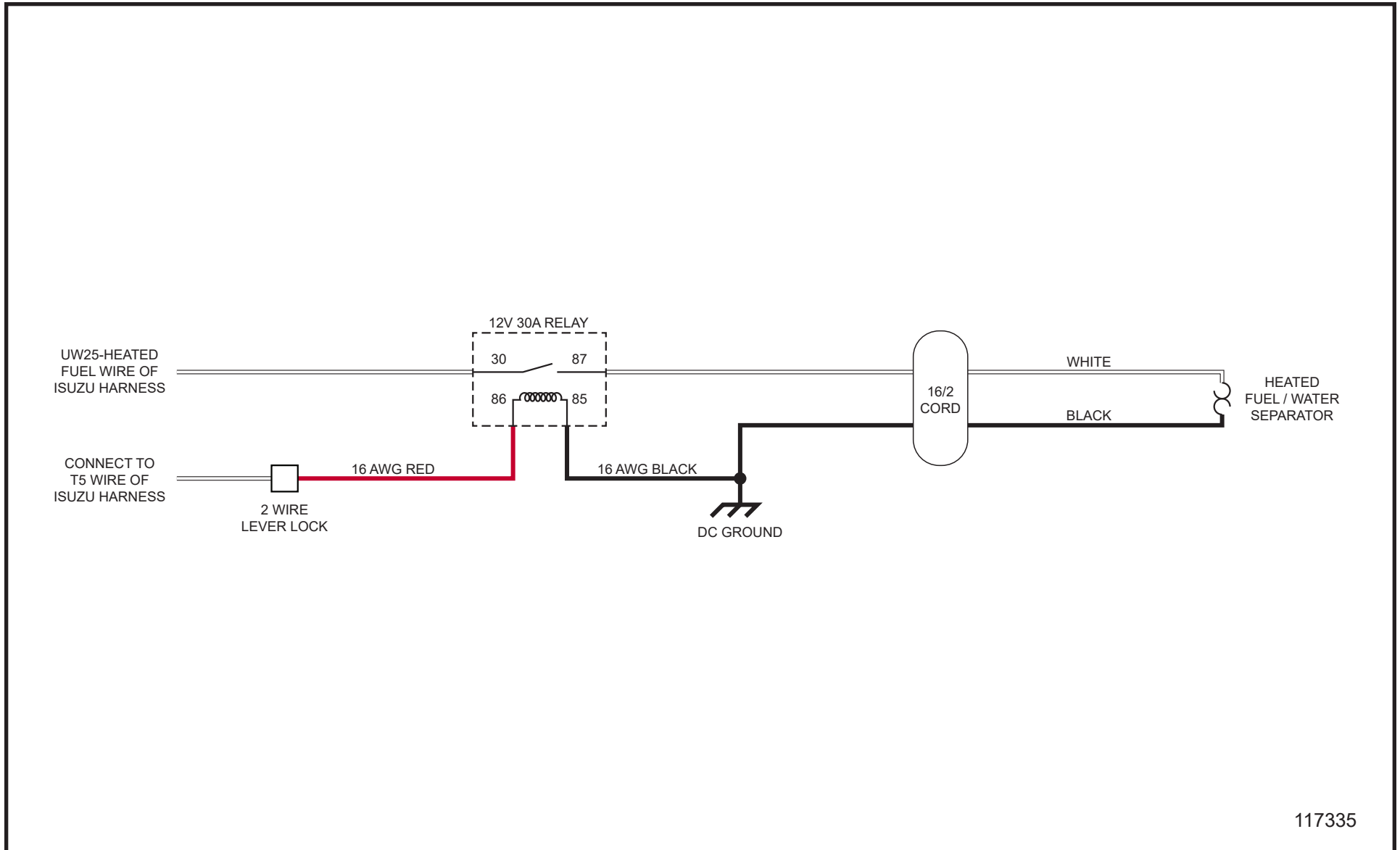

Maxi-Lite

1.46 - LSC or SLS Heated Fuel/Water Separator Schematic

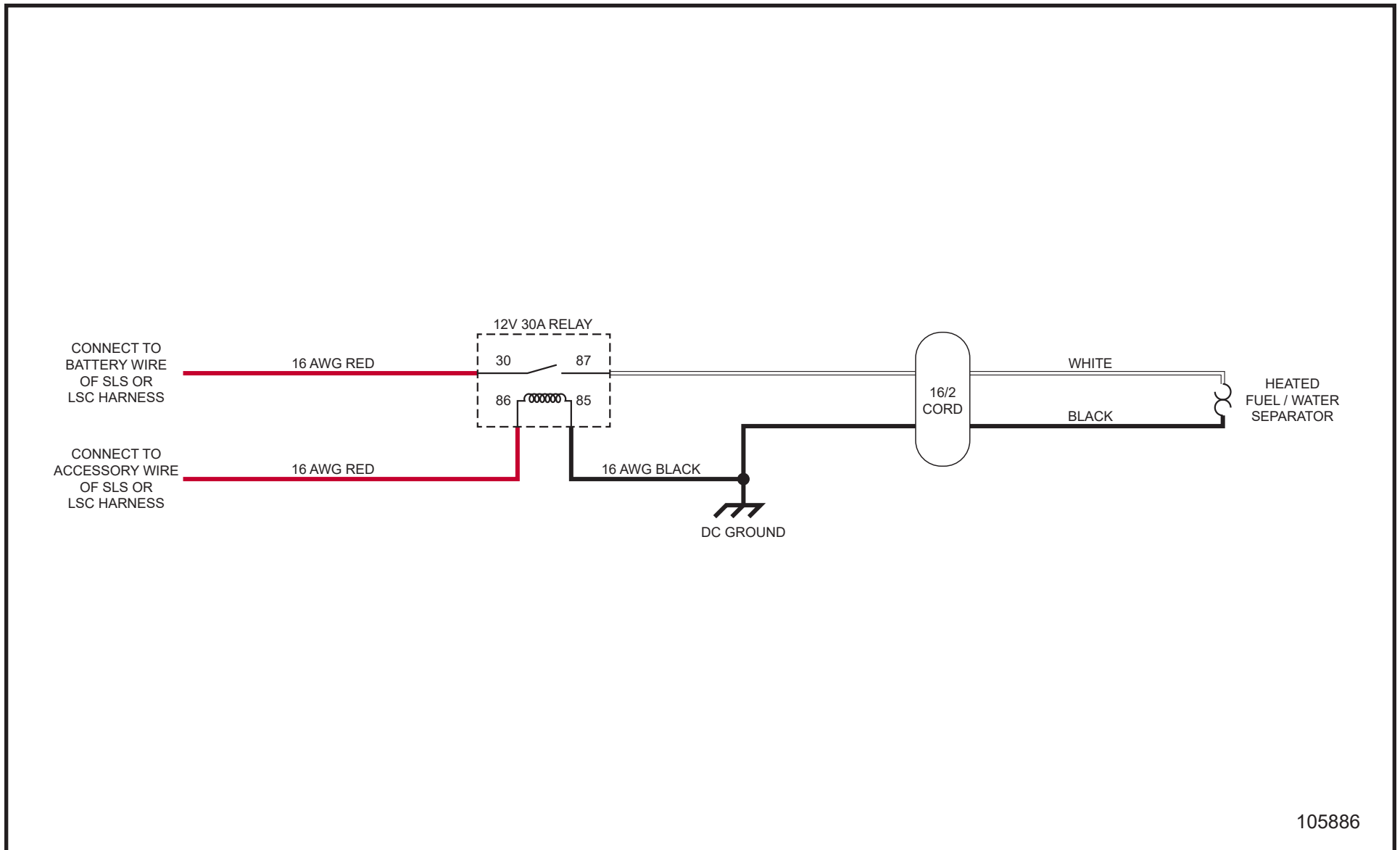

105886

1.47 - Shocker Valve Harness Schematic

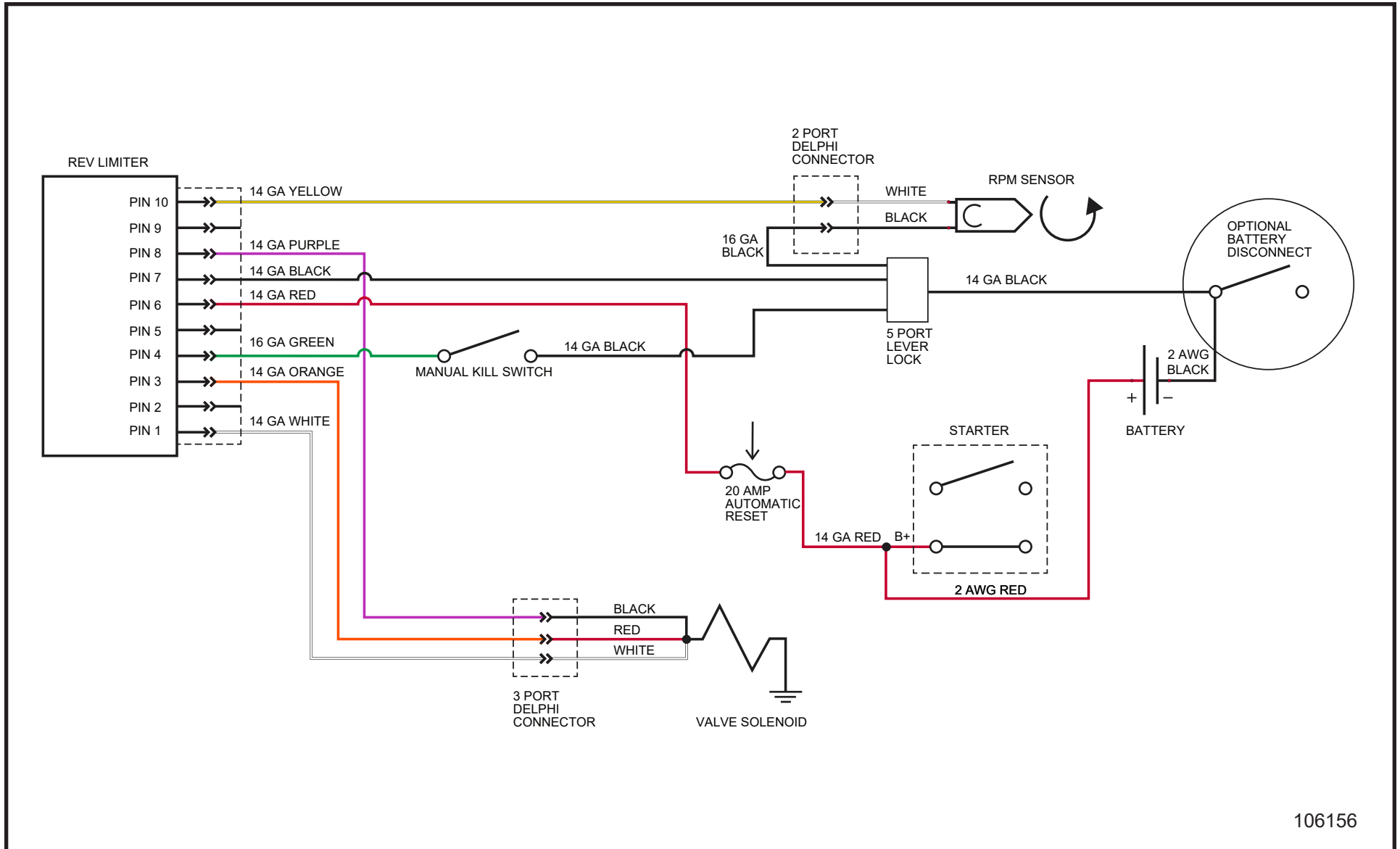

106156

Maxi-Lite

1.48 - Fuel Run Beacon Schematic

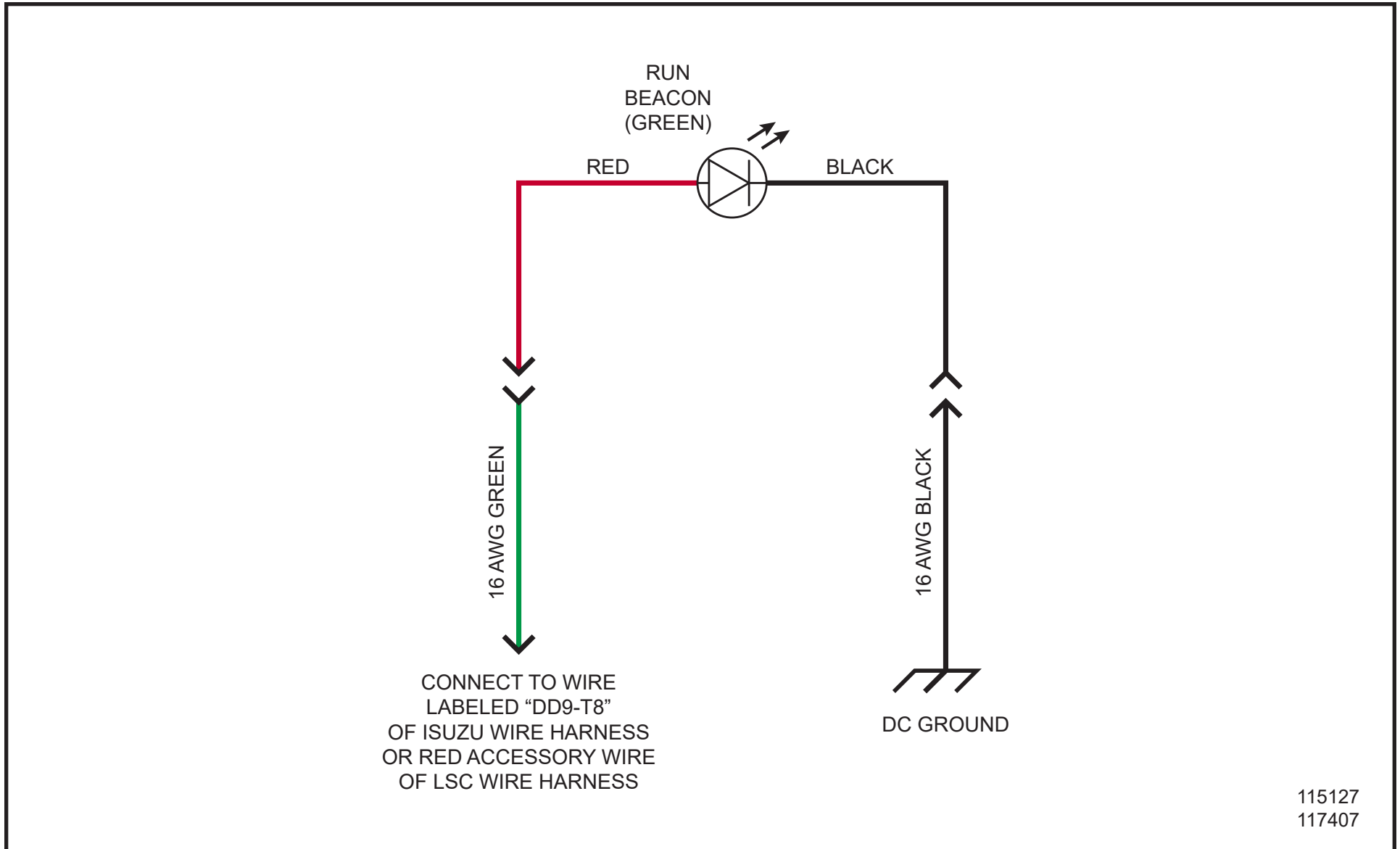

1.49 - Low Fuel Beacon Schematic

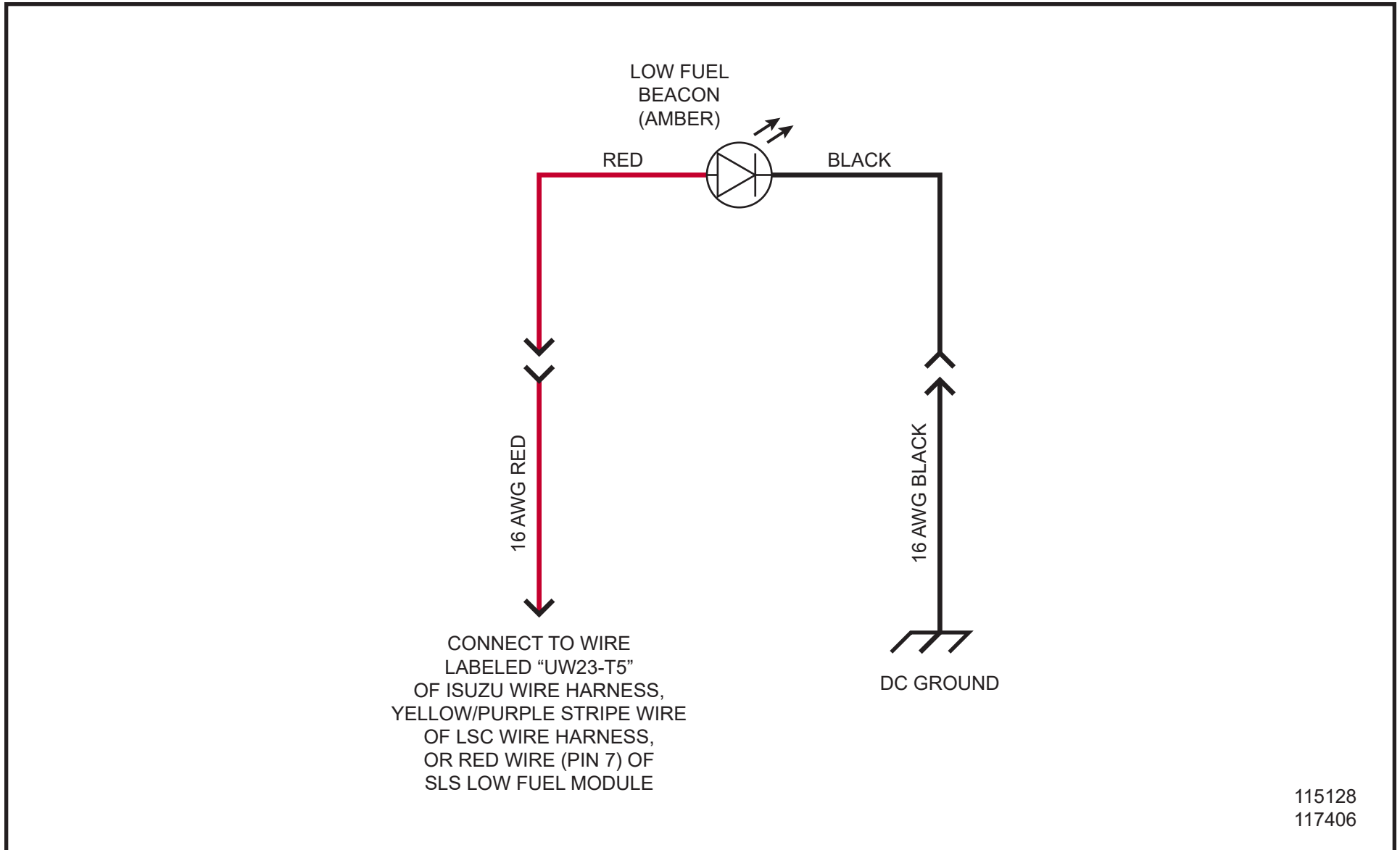

Maxi-Lite

1.50 - Interior Work Light Schematic

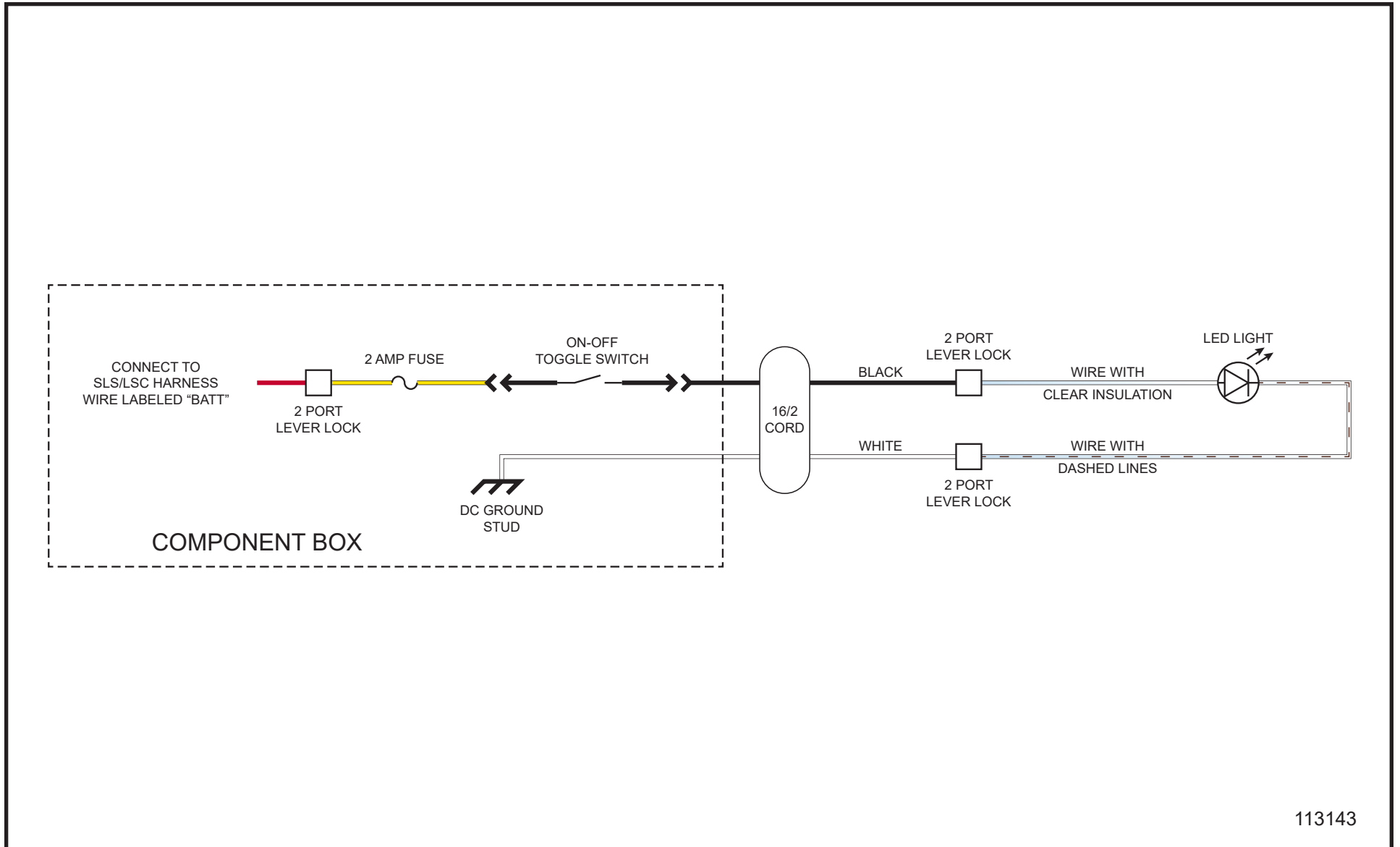

Maxi-Lite