



**(en) Parts Manual
MAXI-POWER™ 25**

TABLE OF CONTENTS

1.0 TRAILER PARTS GROUP

Axle and Wheels	(1.1)
Fenders, Step Plates, and Rear Bumper	(1.2)
Tongue Jack and Coupler Options	(1.3)
Trailer Lighting Group	(1.4)

2.0 ENCLOSURE GROUP

Left Side Panels	(2.1)
Left Side Doors	(2.2)
Right Side Panels	(2.3)
Right Side Doors	(2.4)
Right Side Outlet Panel Door	(2.5)
Rear Side Panel with Emergency Stop Button	(2.6)
Rear Side Control Panel Door	(2.7)
Front Side Panel	(2.8)
Top Side Panel	(2.9)
Left and Right Side Door Latch Brackets	(2.10)

3.0 CONTROL BOX GROUP

Control Panel	(3.1)
Control Box Interior	(3.2)
Isuzu Engine Interface Harness Fuse Box	(3.3)
Connection Lug and Outlet Panel I	(3.4)
Connection Lug and Outlet Panel II	(3.5)
Connection Lug Plate	(3.6)
Camlocks	(3.7)

Maxi-Power™ 25

TABLE OF CONTENTS

4.0 ENGINE AND GENERATOR GROUP

Isuzu 4LE2T Engine Assembly Group	(4.1)
Isuzu 4LE2T Remote Oil Filter	(4.2)
Isuzu 4LE2T Remote Oil Drain	(4.3)
Isuzu 4LE2T Fan Guards	(4.4)
Isuzu 4LE2T Radiator	(4.5)
Coolant Reservoir	(4.6)
Marathon Generator	(4.7)
Engine and Generator Ground Wiring	(4.8)

5.0 FUEL TANK, BATTERY CABLES, AND OPTIONS

Fuel Tank	(5.1)
Remote Fuel Group	(5.2)
Battery Cables Group	(5.3)
Battery Disconnect Group	(5.4)
Block Heater, Battery Heater and Charger	(5.5)

6.0 DECALS

Branding Decals	(6.1)
Front and Rear Side Safety Decals	(6.2)
Right Side Safety Decals	(6.3)
Right Side Interior Safety Decals	(6.4)
Left Side Interior Safety Decals	(6.5)
Top Side Safety Decals	(6.6)
Control Box Safety Decals	(6.7)

1.1 - Axle and Wheels

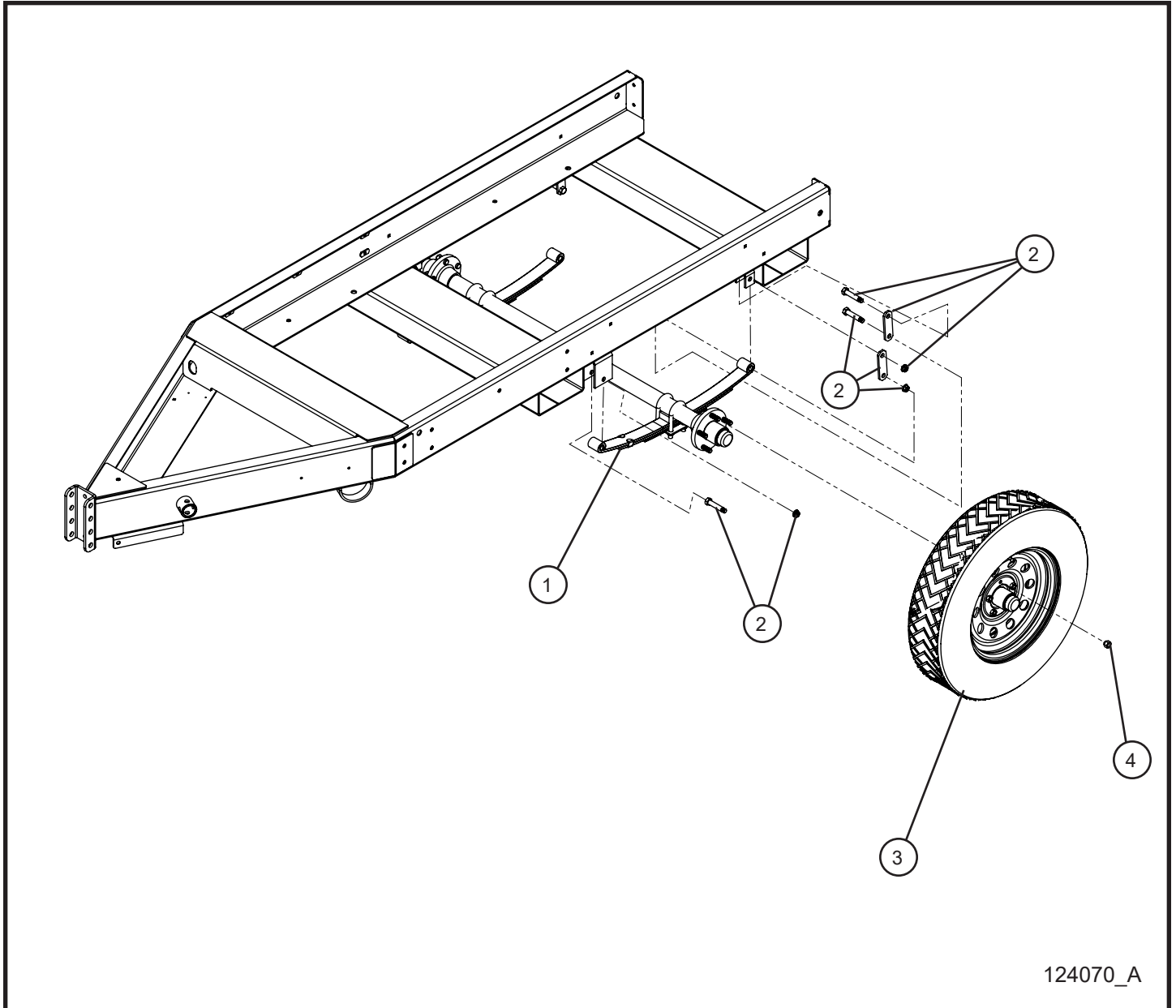

124070_A

Maxi-Power™ 25

SN 48-000001 and UP

1.1 - Axle and Wheels

Item	Part No.	Part Description	Qty.
1	111142	AXLE MAXI-POWER 25	1
2	117120	SUSPENSION KIT SINGLE AXLE	1
3	115003	15" WHEEL/TIRE ASSY RADIAL LRD	2
4	032048	1/2-20 LUG NUT PL	10

NS - Not Shown

* * * - Contact Allmand for more information.

1.2 - Fenders, Step Plates, and Rear Bumper

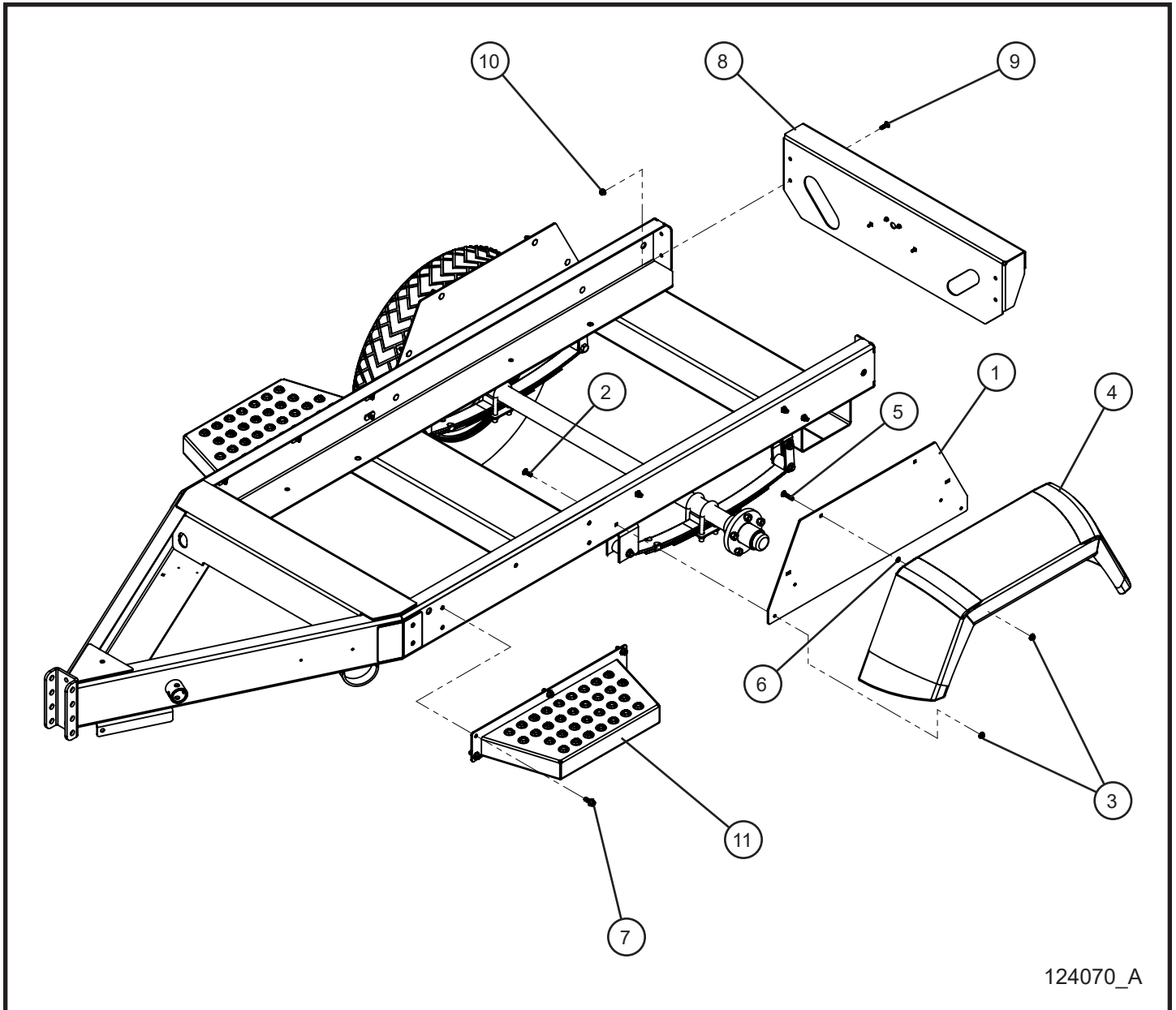

124070_A

Maxi-Power™ 25

SN 48-000001 and UP

1.2 - Fenders, Step Plates, and Rear Bumper

Item	Part No.	Part Description	Qty.
1	111169P	FENDER MOUNT	2
2	053020	5/16-18 X 1 CARRIAGE BOLT	8
3	057006	5/16-18 SERRATED FLANGE NUT	16
4	103066	FENDER 15 INCH	2
5	053023	5/16-18 X 1 1/2 CARRIAGE BOLT	8
6	045217	5/16 PUSH NUT	8
7	056010	3/8-16 X 1 SERRATED FLANGE HEX SCREW	10
8	111157P	WELDMENT BUMPER	1
9	100670	3/8-16 X 1 1/4 CARRIAGE BOLT	4
10	044029	3/8-16 SERRATED FLANGE NUT	4
11	120950P	MP25 TRAILER STEP WELDMENT	2

NS - Not Shown

*** - Contact Allmand for more information.

1.3 - Tongue Jack and Coupler Options

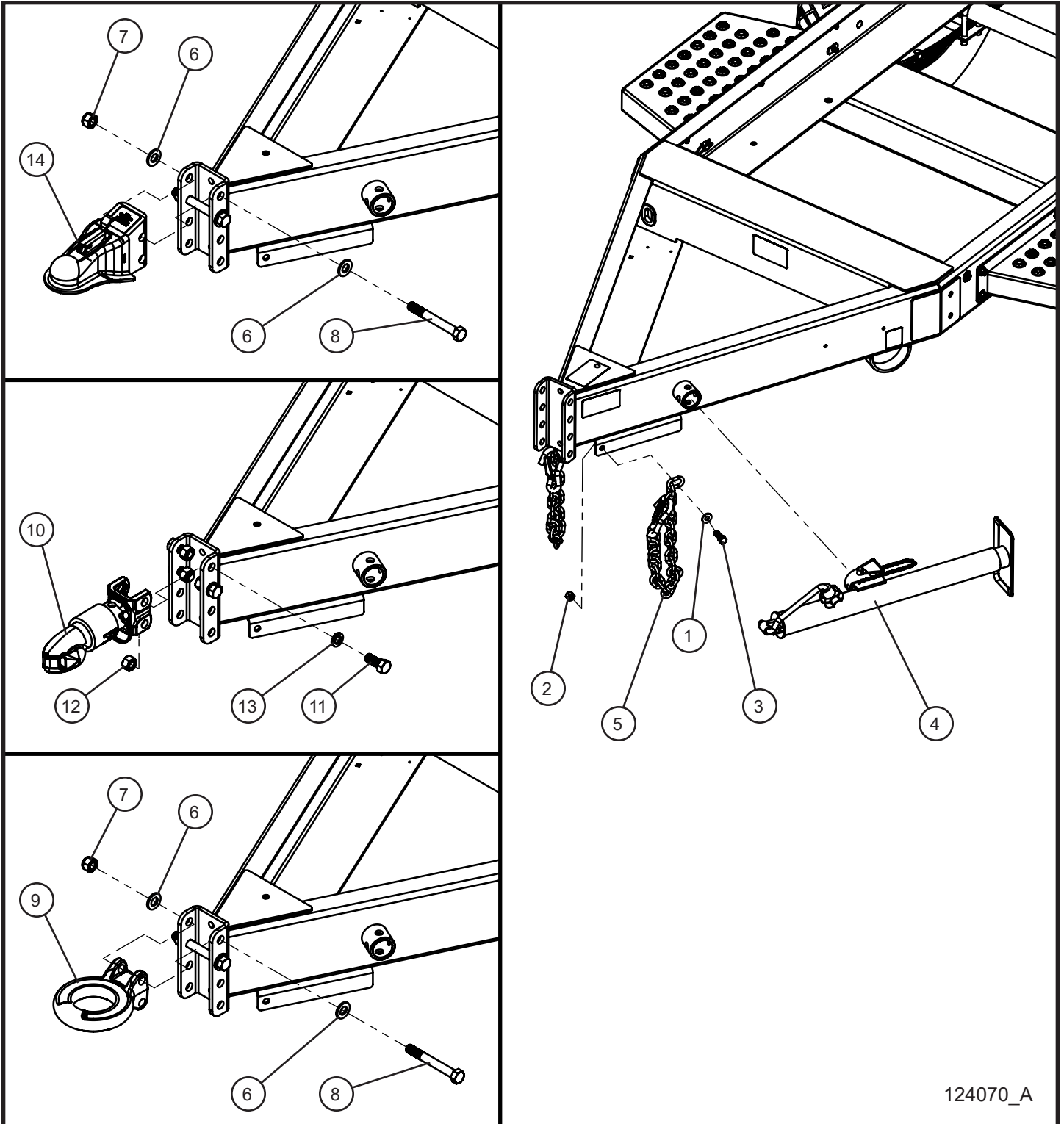

124070_A

Maxi-Power™ 25

SN 48-000001 and UP

1.3 - Tongue Jack and Coupler Options

Item	Part No.	Part Description	Qty.
1	047015	3/8 FLAT WASHER	6
2	057011	7/16-14 HEX NYLOCK FLANGE NUT	2
3	046159	7/16-14 X 1 1/4 HEX HEAD CS	2
4	108727	TOP CRANK TUBE JACK 15.00 TRAVEL	1
5	049040	CHAIN TOW CLASS III 27 IN.	2
6	047031	5/8 FLAT WASHER	4
7	044053	5/8-11 NYLOCK HEX NUT	2
8	046255	5/8-11 x 5 HEX HEAD	2
9	106720	PINTLE RING 3.0 ADJUSTABLE	1
10	109978	COUPLER 2.00 BALL BULLDOG	1
	109979	COUPLER 2.313 BALL BULLDOG	1
11	046245	5/8-11 x 1 1/2 BOLT	4
12	044050	5/8-11 HEX NUT	4
13	043101	5/8 SPLIT LOCK WASHER	4
14	109977	COUPLER BALL 2.00	1
	109976	COUPLER BALL 2.313	1

NS - Not Shown

*** - Contact Allmand for more information.

1.4 - Trailer Lighting Group

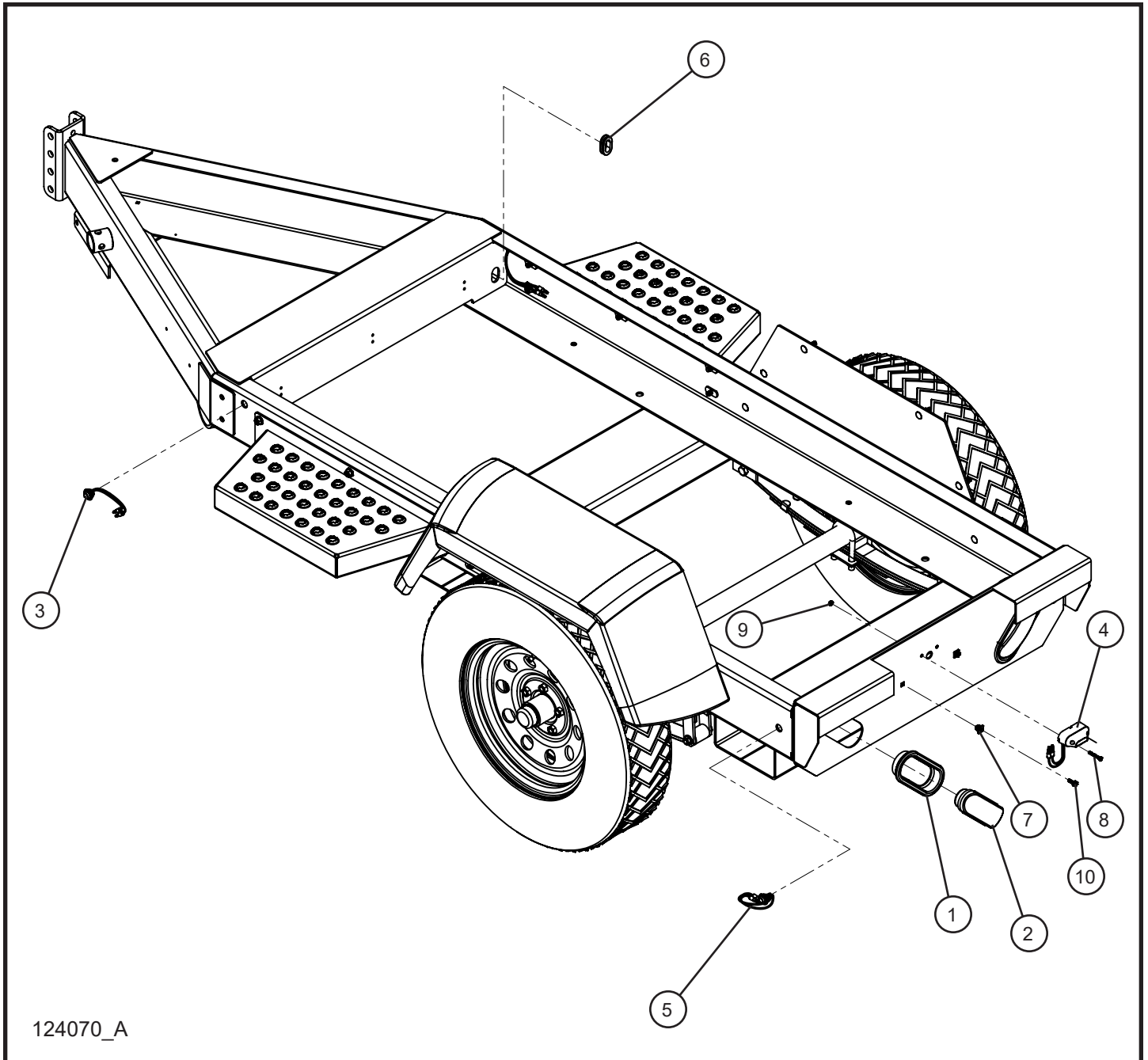

Maxi-Power™ 25

SN 48-000001 and UP

1.4 - Trailer Lighting Group

Item	Part No.	Part Description	Qty.
1	102825	GROMMET 6.50 OVAL LAMP	2
2	102721	LED TAIL LAMP	2
3	106212	MARKER LIGHT AMBER BULLET LED	2
4	115116	LICENSE PLATE LIGHT LED	1
5	106211	MARKER LIGHT RED BULLET LED	2
6	650542	1 1/4 ID X 1 1/2 OD GROMMET	4
7	105408	GROMMET NUT DOUBLE SPLIT SQUARE HEAD	2
8	041040	#10-24 X 1 1/2 PH-ROUND HEAD MS	2
9	057004	#10-24 SERRATED FLANGE HEX NUT	2
10	041070	1/4-20 X 3/4 SL-HEX WASHER HEAD MS	2
NS	115282	TAIL LIGHT HARNESS MAXI-AIR 100	1
NS	112266	SCHEMATIC TAIL LIGHT HARNESS MA100, MA185 & NLV	1

NS - Not Shown

* * * - Contact Allmand for more information.

2.1 - Left Side Panels

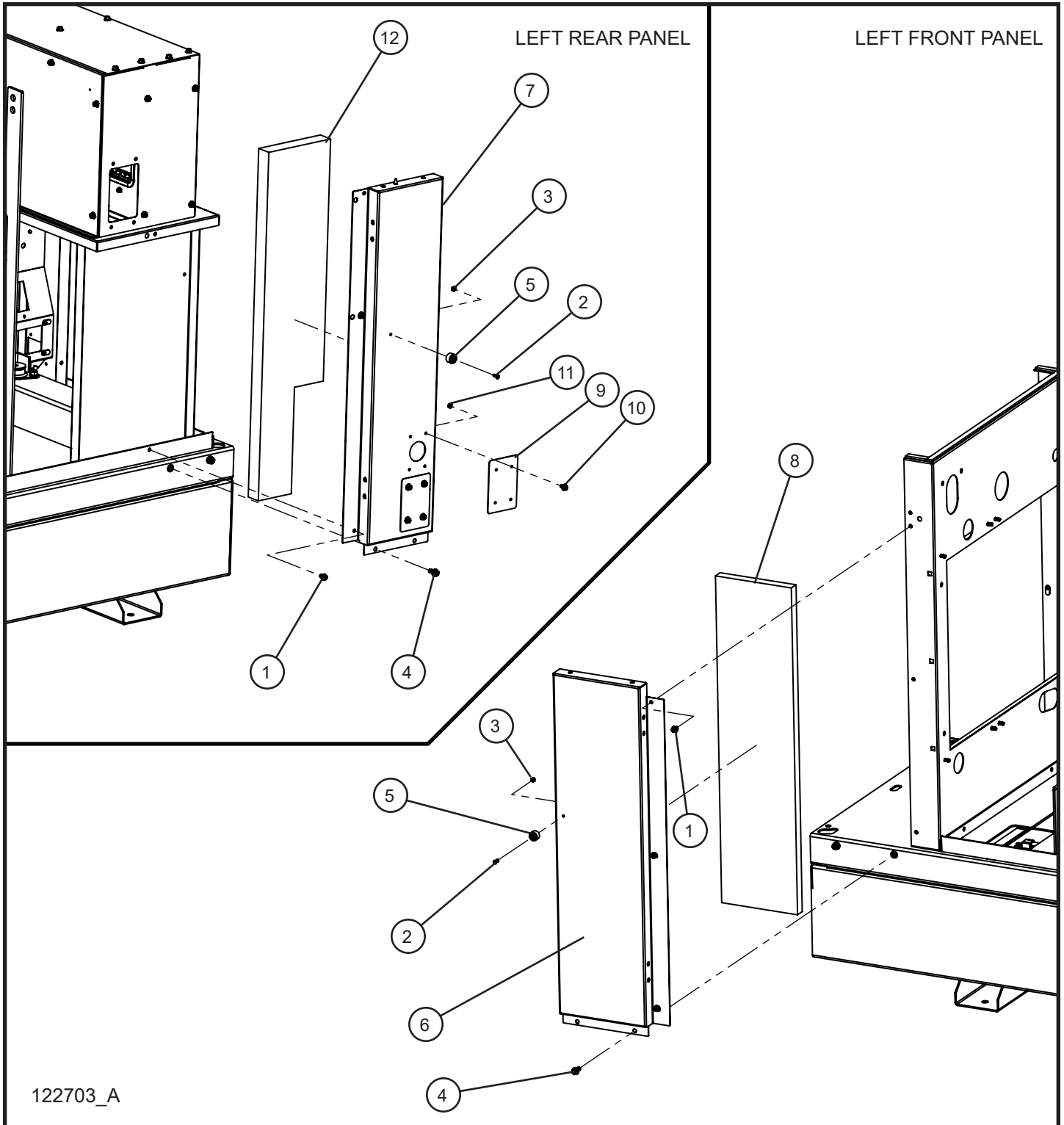

Maxi-Power™ 25

SN 48-000001 and UP

2.1 - Left Side Panels

Item	Part No.	Part Description	Qty.
1	056001	1/4-20 X 1/2 HEX SERRATED FLANGE SCREW	19
2	121047	18-8 SS BUTTON HEAD HEX DRIVE SCREW	5
3	044018	#10-24 NYLOCK HEX NUT	5
4	056038	5/16-18 X 3/4 HEX FLANGE SCREW	15
5	121582	RUBBER BUMPER .87 OD X .53 THK	5
6	121009P	WELDMENT OUTSIDE PANEL FRONT LEFT MP25	1
7	121005P	WELDMENT OUTSIDE PANEL LEFT REAR MP25	1
8	122728	FOAM KIT MAXI-POWER 25	1
	121002	FOAM OUTSIDE PANEL FRONT SIDE MP25	1
9	121166P	COVER PLATE OUTLETS	2
10	041017	#6-32 X 3/8 PH-PAN HEAD MS	8
11	044004	#6-32 KEPS HEX NUT	8
12	122728	FOAM KIT MAXI-POWER 25	1
	121006	FOAM OUTSIDE PANEL CONNECTOR MP25	1

NS - Not Shown

*** - Contact Allmand for more information.

2.2 - Left Side Doors

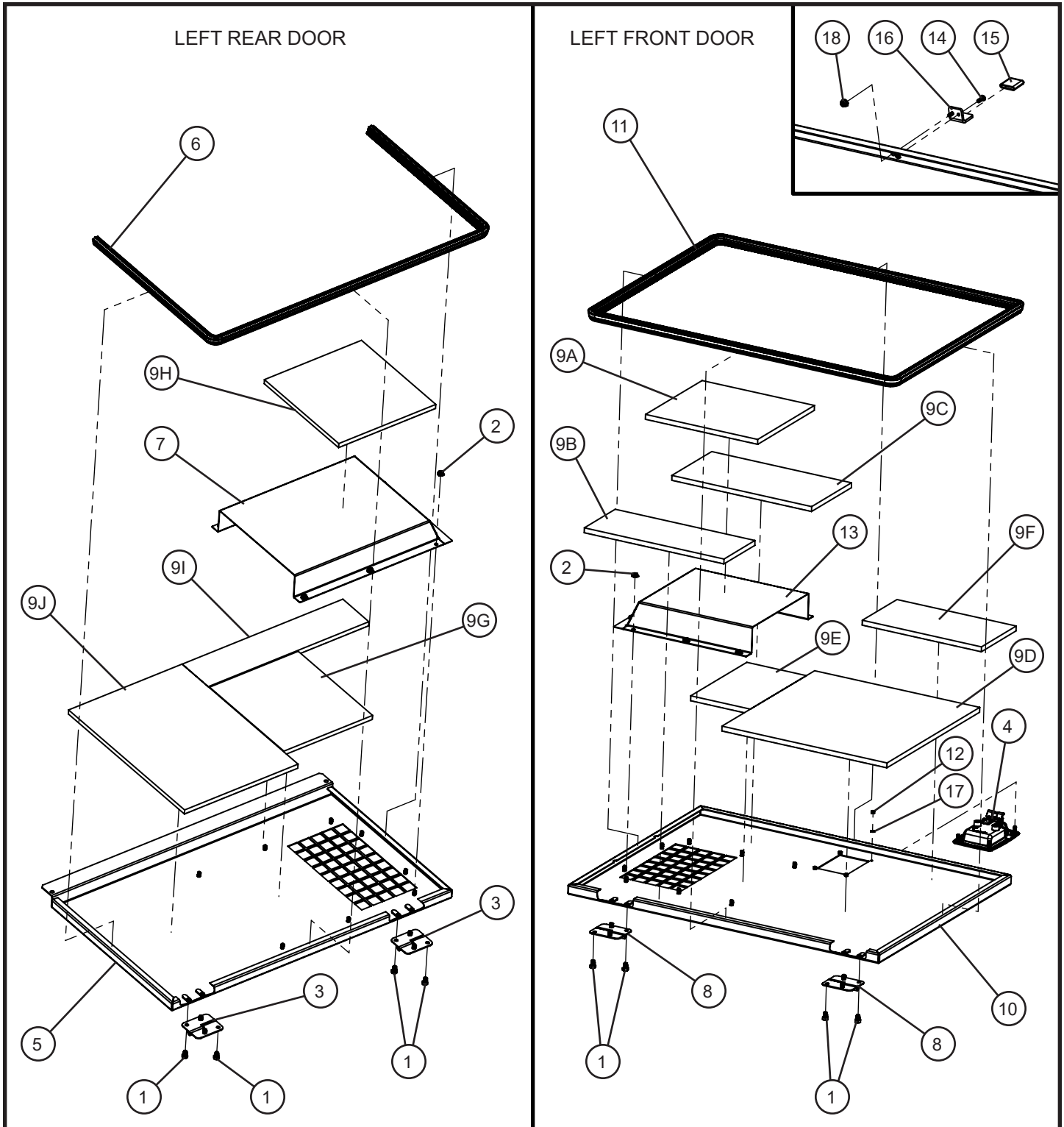

Maxi-Power™ 25

SN 48-000001 and UP

2.2 - Left Side Doors

Item	Part No.	Part Description	Qty.
1	046046	5/16-18 X 1/2 HEX HEAD CS	16
2	057000	1/4-20 HEX SERRATED FLANGE NUT	16
3	122016	RIGHT HAND HINGE REMOVABLE 5/16 HOLES MAXI-POWER	2
4	118647	LOCKABLE SLAM LATCH BLACK FOR ROD CATCH	1
5	121174P	WELDMENT DOOR LEFT REAR MP25	1
6	121159	TRIM GASKET SIDE BULB WITH BEADS .031-.141 X 70.50	1
7	121176P	PANEL AIR DUCT LEFT FRONT DOOR MP25	1
8	118638	LEFT HAND HINGE REMOVABLE 5/16 HOLES MAXI-POWER	4
9	122728	FOAM KIT MAXI-POWER 25	1
9A	121078	FOAM LEFT SIDE FRONT DOOR	1
9B	121079	FOAM LEFT SIDE FRONT DOOR	1
9C	121080	FOAM LEFT SIDE FRONT DOOR	1
9D	121170	FOAM LEFT SIDE FRONT DOOR	1
9E	121171	FOAM LEFT SIDE FRONT DOOR	1
9F	121172	HEAT SHIELD FOAM LEFT SIDE FRONT DOOR	1
9G	121178	FOAM AIR BOX INSIDE LEFT SIDE REAR DOOR	1
9H	121179	FOAM AIR BOX LEFT SIDE REAR DOOR	1
9I	121180	FOAM LEFT SIDE REAR DOOR	1
9J	121181	HEAT SHIELDING LEFT SIDE REAR DOOR	1
10	121075P	WELDMENT DOOR LEFT FRONT MP25	1
11	121159	TRIM GASKET SIDE BULB WITH BEADS .031-.141 X 113.25	1
12	042076	M5X.8 NYLON INSERT	4
13	121077P	PANEL LEFT FRONT DOOR AIR BOX	2
14	041012	SCREW MS #8-32 X 1/2	2
15	122723	FINISHING CAP BLACK RECTANGULAR 0.125 X 1.000 X 1.000	1
16	121161P	BRACKET DOOR HOLD	1
17	047070	#10 FLAT WASHER	4
18	057003	#8-32 SERRATED FLANGE HEX LOCKNUT	2

NS - Not Shown

*** - Contact Allmand for more information.

2.3 - Right Side Panels

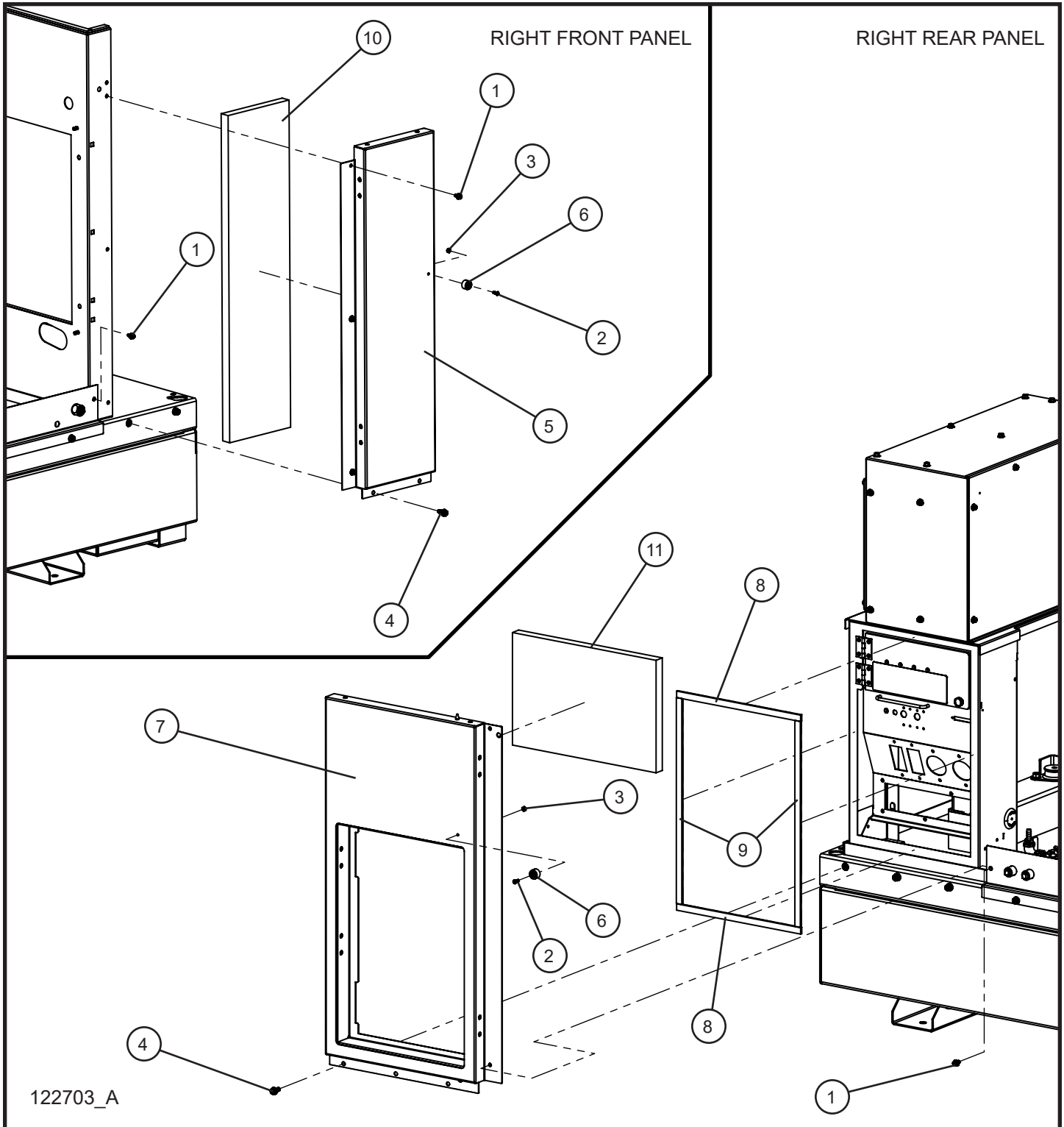

Maxi-Power™ 25

SN 48-000001 and UP

2.3 - Right Side Panels

Item	Part No.	Part Description	Qty.
1	056001	1/4-20 X 1/2 HEX SERRATED FLANGE SCREW	19
2	121047	18-8 SS BUTTON HEAD HEX DRIVE SCREW	5
3	044018	#10-24 NYLOCK HEX NUT	5
4	056038	5/16-18 X 3/4 HEX FLANGE SCREW	15
5	121001P	WELDMENT OUTSIDE PANEL RIGHT FRONT MP25	1
6	121582	RUBBER BUMPER .87 OD X .53 THK	5
7	121063P	WELDMENT OUTSIDE PANEL REAR RIGHT MP25	1
8	121067	FOAM STRIP .188 X .625 X 14.25 INCHES	2
9	121067	FOAM STRIP .188 X .625 X 20.125 INCHES	2
10	122728	FOAM KIT MAXI-POWER 25	1
	121002	FOAM OUTSIDE PANEL FRONT SIDE MP25	1
11	122728	FOAM KIT MAXI-POWER 25	1
	121066	FOAM OUTSIDE PANEL REAR RIGHT MP25	1

NS - Not Shown

* * * - Contact Allmand for more information.

2.4 - Right Side Doors

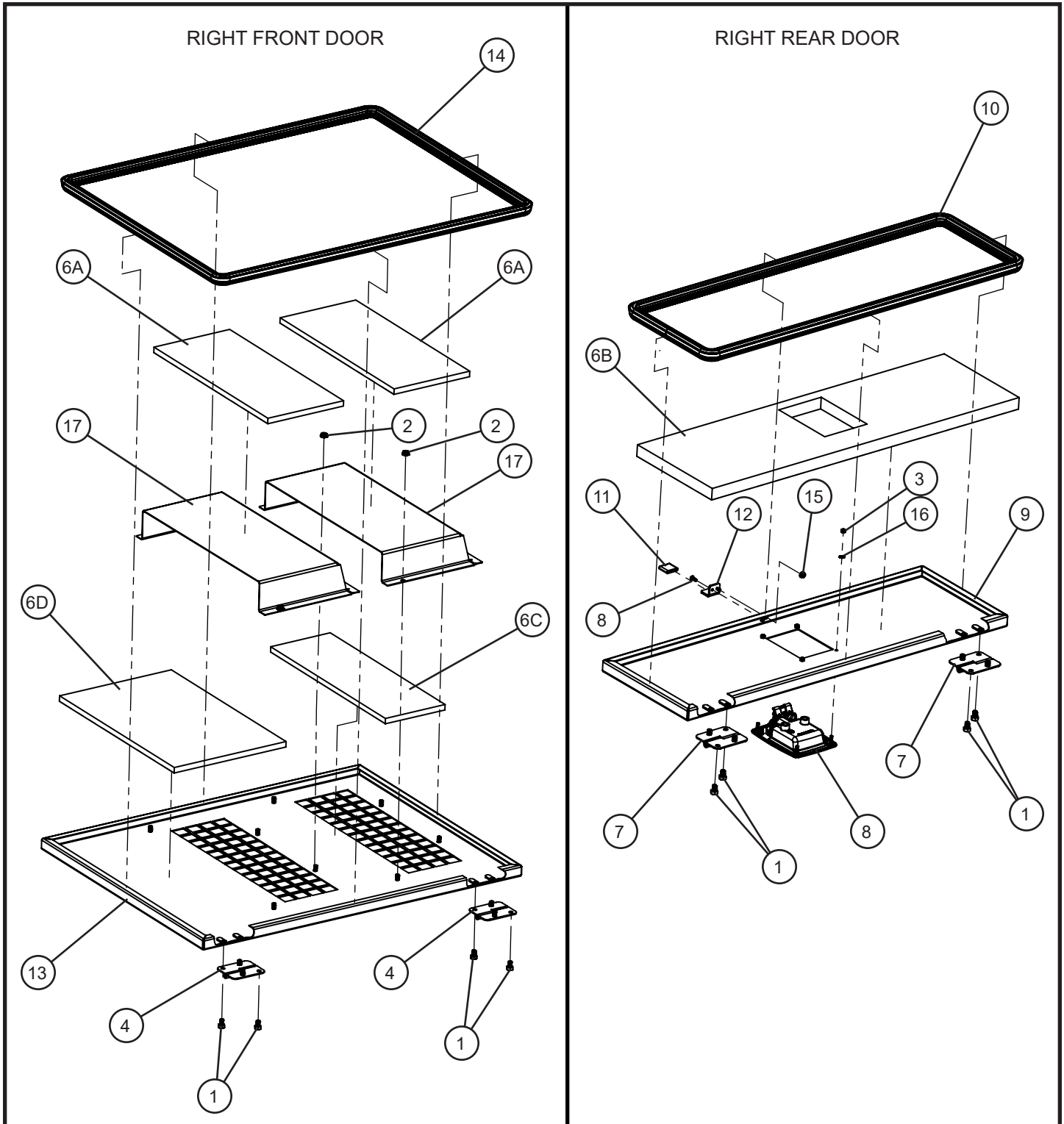

Maxi-Power™ 25

SN 48-000001 and UP

2.4 - Right Side Doors

Item	Part No.	Part Description	Qty.
1	046046	5/16-18 X 1/2 HEX HEAD CS	16
2	057000	1/4-20 HEX SERRATED FLANGE NUT	8
3	042076	M5X.8 NYLON INSERT	4
4	122016	RIGHT HAND HINGE REMOVABLE 5/16 HOLES MAXI-POWER	2
5	118647	LOCKABLE SLAM LATCH BLACK FOR ROD CATCH	1
6	122728	FOAM KIT MAXI-POWER 25	1
6A	121168	DOOR AIR BOX RIGHT SIDE FRONT FOAM-2 MP25	2
6B	121160	DOOR RIGHT REAR FOAM MP25	1
6C	121169	DOOR AIR BOX RIGHT SIDE FRONT FOAM-3 MP25	1
6D	121201	DOOR AIR BOX RIGHT SIDE FRONT FOAM-4 MP25	1
7	118638	LEFT HAND HINGE REMOVABLE 5/16 HOLES MAXI-POWER	4
8	041012	SCREW MS #8-32 X 1/2	2
9	121157P	WELDMENT DOOR RIGHT REAR MP25	1
10	121159	TRIM GASKET SIDE BULB WITH BEADS .031-.141 X 79.5	1
11	122723	FINISHING CAP BLACK RECTANGULAR 0.125 X 1.000 X 1.000	1
12	121161P	BRACKET DOOR HOLD	1
13	121164P	WELDMENT DOOR RIGHT FRONT MP25	1
14	121159	TRIM GASKET SIDE BULB WITH BEADS .031-.141 X 108.5	1
15	057003	#8-32 SERRATED FLANGE HEX LOCKNUT	2
16	047070	#10 FLAT WASHER	4
17	120923P	PANEL RIGHT FRONT DOOR AIR BOX MP25	2

NS - Not Shown

* * * - Contact Allmand for more information.

2.5 - Right Side Outlet Panel Door

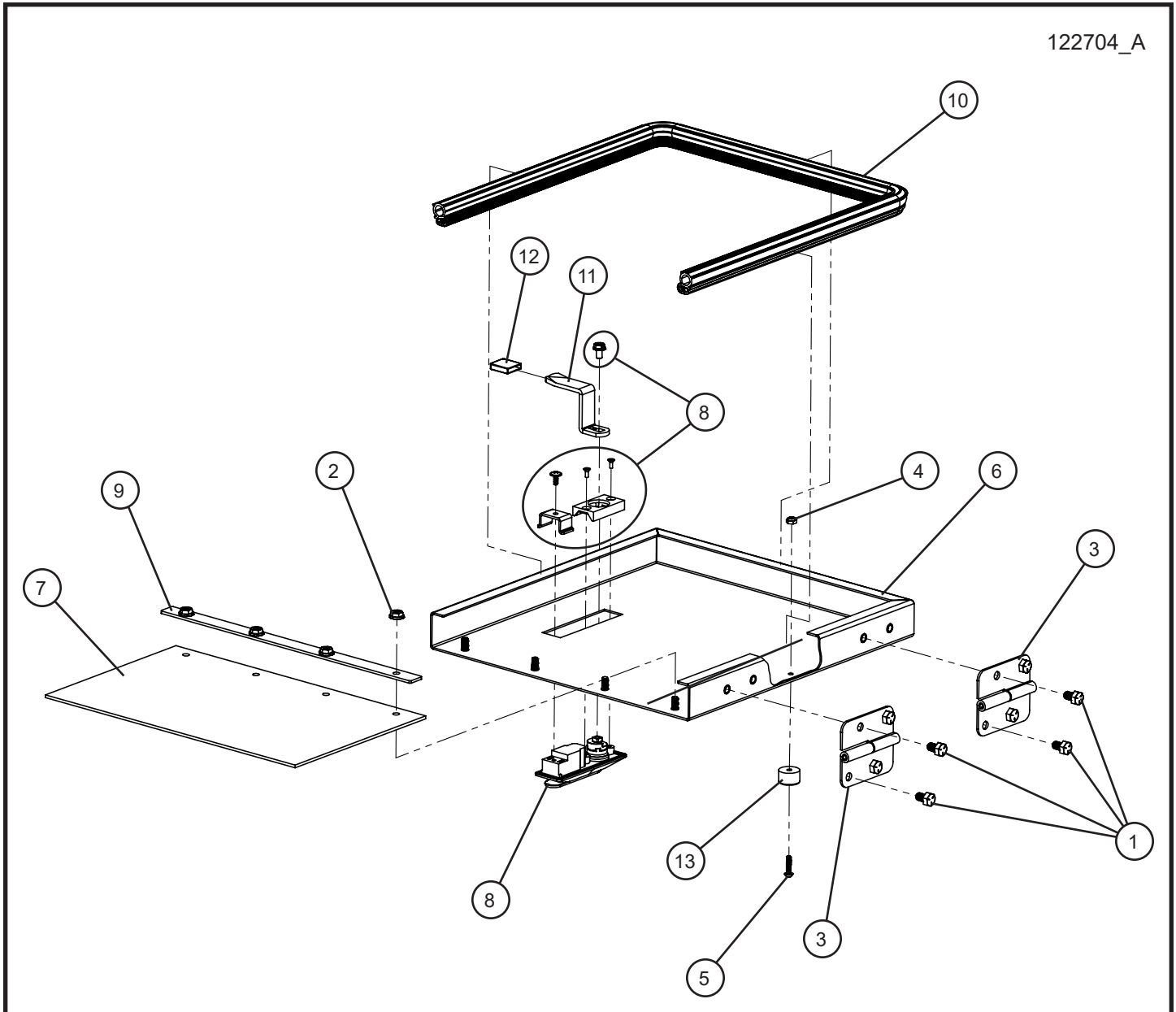

Maxi-Power™ 25

SN 48-000001 and UP

2.5 - Right Side Outlet Panel Door

Item	Part No.	Part Description	Qty.
1	046046	5/16-18 X 1/2 HEX HEAD CS	8
2	057000	1/4-20 HEX SERRATED FLANGE NUT	4
3	122016	RIGHT HAND HINGE REMOVABLE 5/16 HOLES MAXI-POWER	8
4	044018	#10-24 NYLOCK HEX NUT	1
5	041027	#10-24 X 3/4 PH-ROUND HEAD MS	1
6	121070P	DOOR ELECTRICAL PANEL WELDMENT MP25	1
7	123586	FLAP ELECTRICAL DOOR MP25	1
8	118646	QUARTER TURN DISCRETE LATCH LOCKABLE	1
9	121073P	PLATE ELECTRICAL DOOR FLAP BACKING MP25	1
10	121159	TRIM GASKET SIDE BULB WITH BEADS .031-.141 X 39.375	1
11	122726	DOOR LATCH CAM	1
12	122727	COVER DOOR LATCH CAM	1
13	121582	RUBBER BUMPER .87 OD X .53 THK	1

NS - Not Shown

* * * - Contact Allmand for more information.

2.6 - Rear Side Panel with Emergency Stop Button

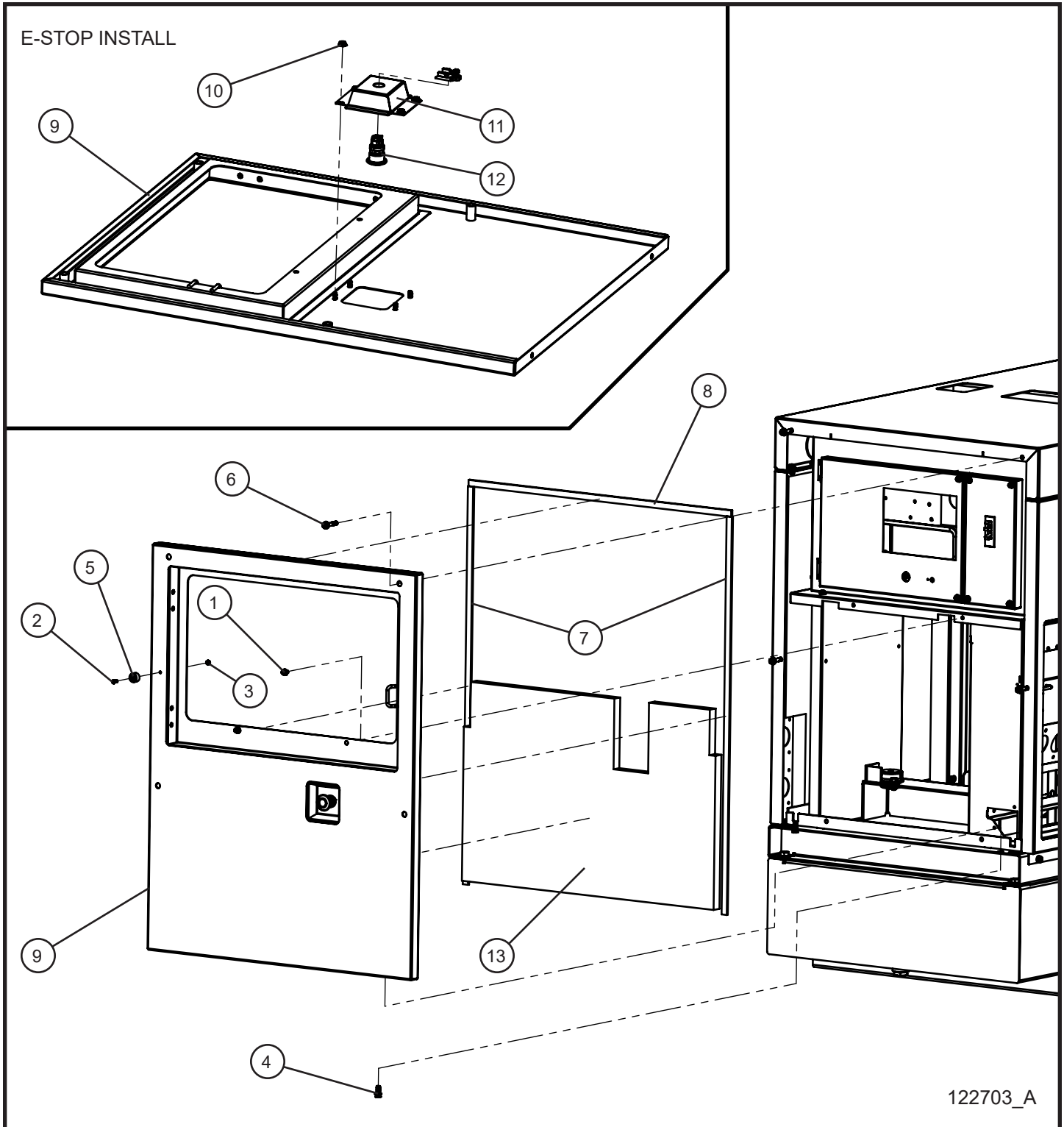

Maxi-Power™ 25

SN 48-000001 and UP

2.6 - Rear Side Panel with Emergency Stop Button

Item	Part No.	Part Description	Qty.
1	056001	1/4-20 X 1/2 HEX SERRATED FLANGE SCREW	19
2	121047	18-8 SS BUTTON HEAD HEX DRIVE SCREW	5
3	044018	#10-24 NYLOCK HEX NUT	5
4	056038	5/16-18 X 3/4 HEX FLANGE SCREW	15
5	121582	RUBBER BUMPER .87 OD X .53 THK	5
6	056041	5/16-18 X 1-3/4 HEX FLANGE SCREW	8
7	121067	FOAM STRIP .188 X .625 X 39.375 INCHES	2
8	121067	FOAM STRIP .188 X .625 X 31.312 INCHES	1
9	121020P	WELDMENT PANEL REAR MP25	1
10	057000	1/4-20 HEX SERRATED FLANGE NUT	4
11	121017P	PANEL EMERGENCY STOP BOX	1
12	108912	40MM PUSH-PULL EMERGENCY STOP 22MM MOUNTING	1
13	122728	FOAM KIT MAXI-POWER 25	1
	121021	FOAM OUTSIDE PANEL REAR MP25	1

NS - Not Shown

* * * - Contact Allmand for more information.

2.7 - Rear Side Control Panel Door

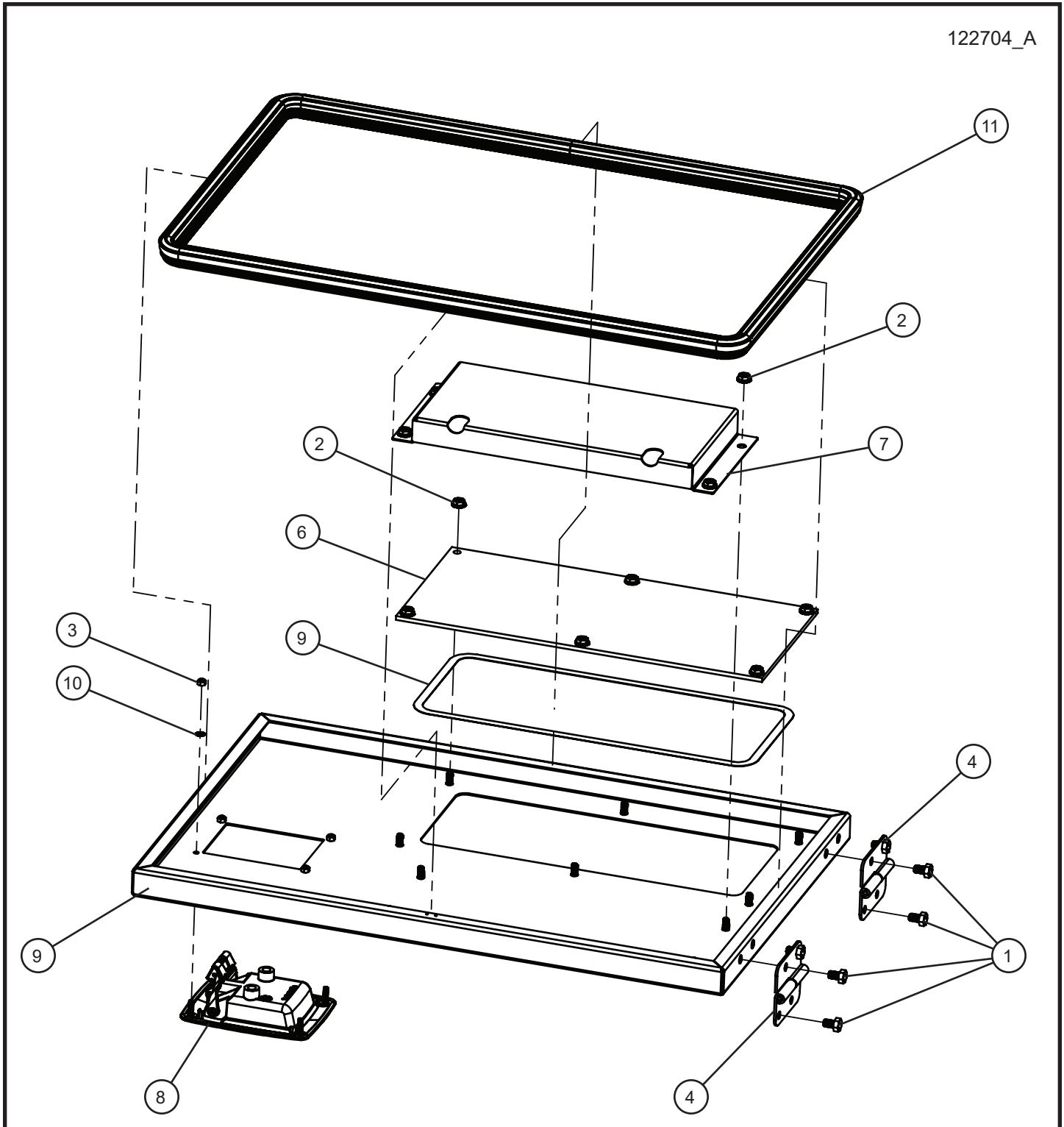

Maxi-Power™ 25

SN 48-000001 and UP

2.7 - Rear Side Control Panel Door

Item	Part No.	Part Description	Qty.
1	046046	5/16-18 X 1/2 HEX HEAD CS	8
2	057000	1/4-20 HEX SERRATED FLANGE NUT	10
3	042076	M5X.8 NYLON INSERT	4
4	122016	RIGHT HAND HINGE REMOVABLE 5/16 HOLES MAXI-POWER	2
5	121183P	WELDMENT REAR ENCLOSURE DOOR	1
6	121187	WINDOW REAR DOOR MP25	1
7	121185P	TOOL BOX	1
8	118647	LOCKABLE SLAM LATCH BLACK FOR ROD CATCH	1
9	121046	ADHESIVE BACKED EPDM FOAM STRIP X 41.13	1
10	047070	#10 FLAT WASHER	4
11	121159	TRIM GASKET SIDE BULB WITH BEADS .031-.141 X 81.188	1

NS - Not Shown

* * * - Contact Allmand for more information.

2.8 - Front Side Panel

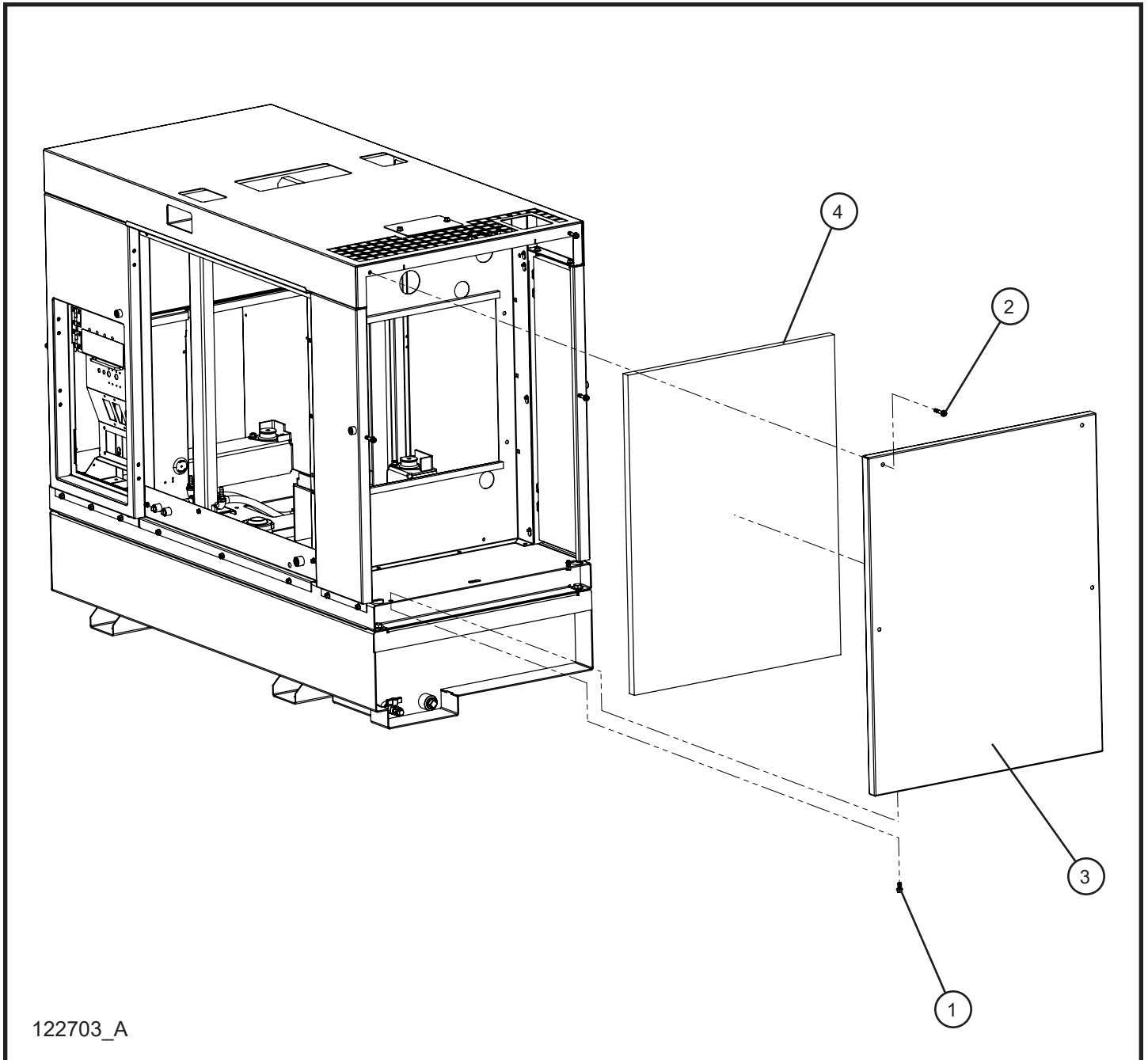

Maxi-Power™ 25

SN 48-000001 and UP

2.8 - Front Side Panel

Item	Part No.	Part Description	Qty.
1	056038	5/16-18 X 3/4 HEX FLANGE SCREW	15
2	056041	5/16-18 X 1-3/4 HEX FLANGE SCREW	8
3	121013P	WELDMENT PANEL FRONT MP25	1
4	122728	FOAM KIT MAXI-POWER 25	1
	121014	FOAM OUTSIDE PANEL FRONT MP25	1

NS - Not Shown

* * * - Contact Allmand for more information.

2.9 - Top Side Panel (1 of 2)

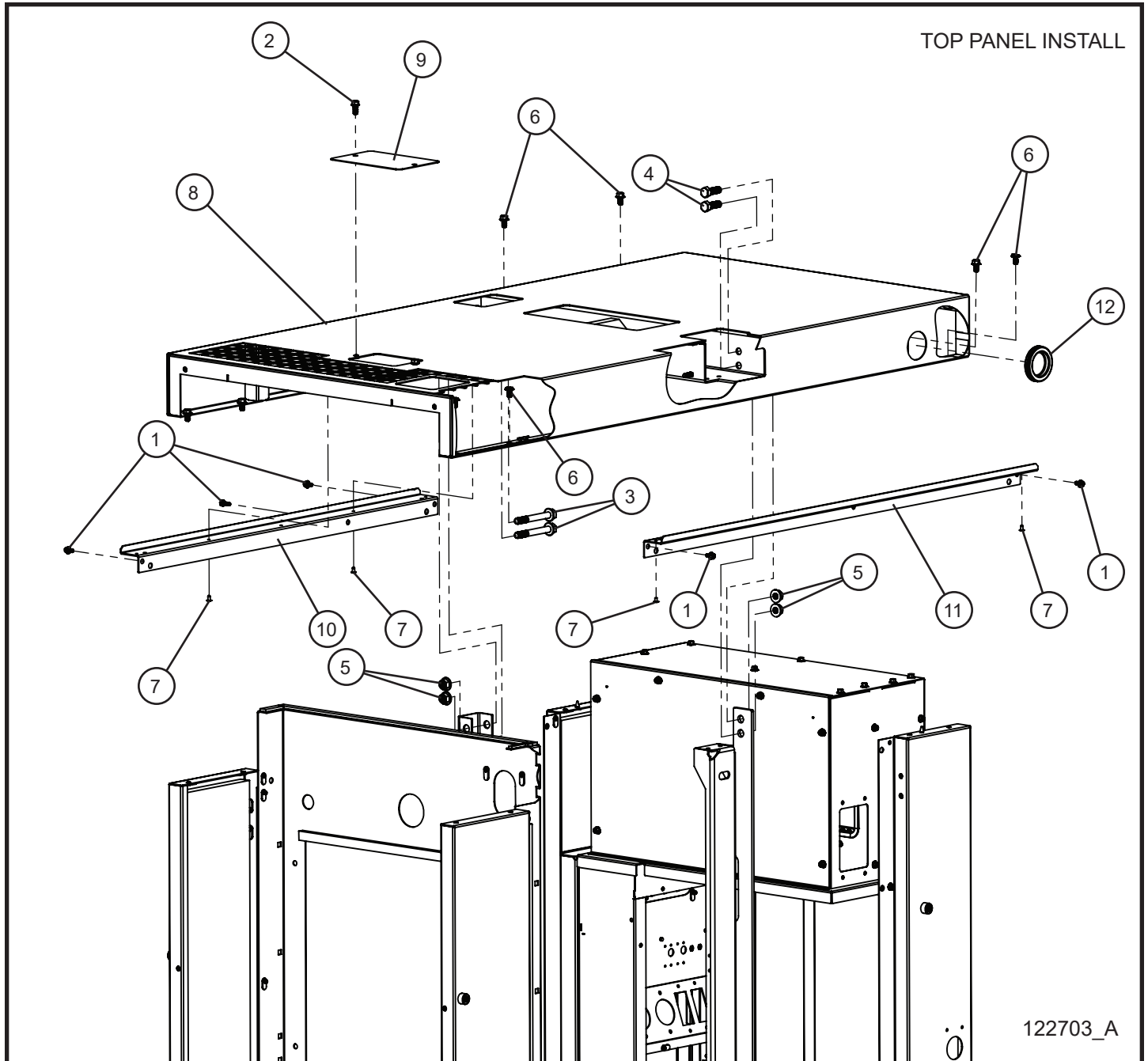

Maxi-Power™ 25

SN 48-000001 and UP

2.9 - Top Side Panel (1 of 2)

Item	Part No.	Part Description	Qty.
1	056001	1/4-20 X 1/2 HEX SERRATED FLANGE SCREW	19
2	056038	5/16-18 X 3/4 HEX FLANGE SCREW	15
3	056025	1/2-13 X 4 HEX FLANGE SCREW	2
4	046184	1/2-13 X 1 1/2 HEX HEAD	2
5	057009	1/2-13 HEX NYLOCK FLANGE NUT	4
6	121920	5/16-18 X 5/8 SERRATED FLANGE HEX SCREW	8
7	118863	RIVET 3/16 DIA . X .325 L .063 TO .125 GRIP	11
8	121041P	WELDMENT TOP COVER MP25	1
9	121043P	PLATE RADIATOR ACCESS COVER MP25/MP45	1
10	121038P	BRACKET DRIP EDGE RIGHT SIDE MP25	1
11	121039P	WELDMENT DRIP EDGE MP25	1
12	110370	GROMMET SOLID 2.047 X 2.323 X .512	1

NS - Not Shown

* * * - Contact Allmand for more information.

2.9 - Top Side Panel (1 of 2)

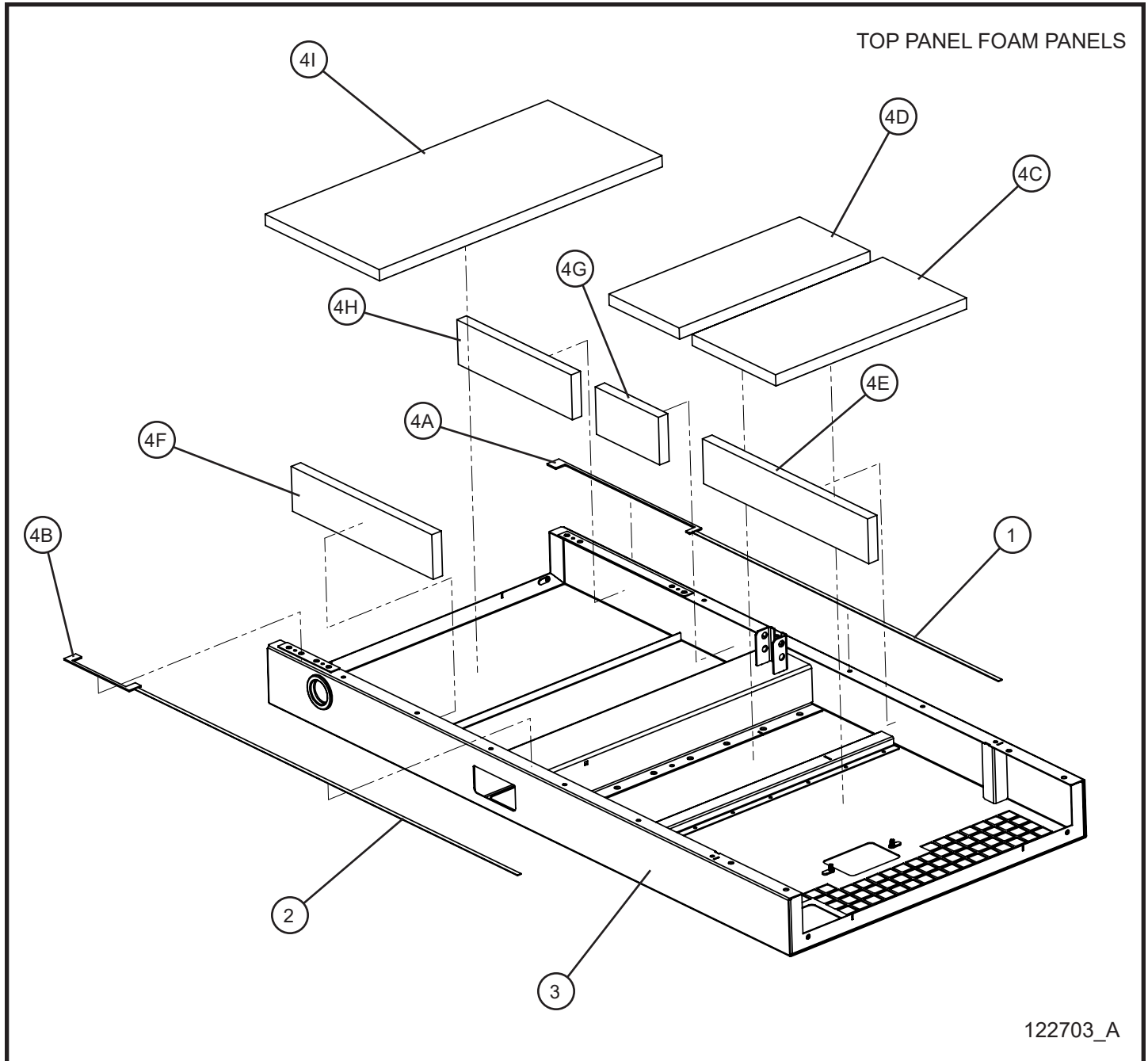

Maxi-Power™ 25

SN 48-000001 and UP

2.9 - Top Side Panel (1 of 2)

Item	Part No.	Part Description	Qty.
1	121046	FOAM STRIP .063 X .375 X 37.5 INCHES	1
2	121046	FOAM STRIP .063 X .375 X 47 INCHES	1
3	121041P	WELDMENT TOP COVER MP25	1
4	122728	FOAM KIT MAXI-POWER 25	1
4A	121044	TOP COVER FOAM SEAL-REAR RIGHT SIDE MP25	1
4B	121045	TOP COVER FOAM SEAL-REAR LEFT SIDE MP25	1
4C	121048	TOP COVER FOAM-1 MP25	1
4D	121049	TOP COVER FOAM-2 MP25	1
4E	121151	TOP COVER FOAM-3 MP25	1
4F	121152	TOP COVER FOAM-4 MP25	1
4G	121153	TOP COVER FOAM-5 MP25	1
4H	121154	TOP COVER FOAM-6 MP25	1
4I	121155	TOP COVER FOAM-7 MP25	1

NS - Not Shown

* * * - Contact Allmand for more information.

2.10 - Left and Right Side Door Latch Brackets

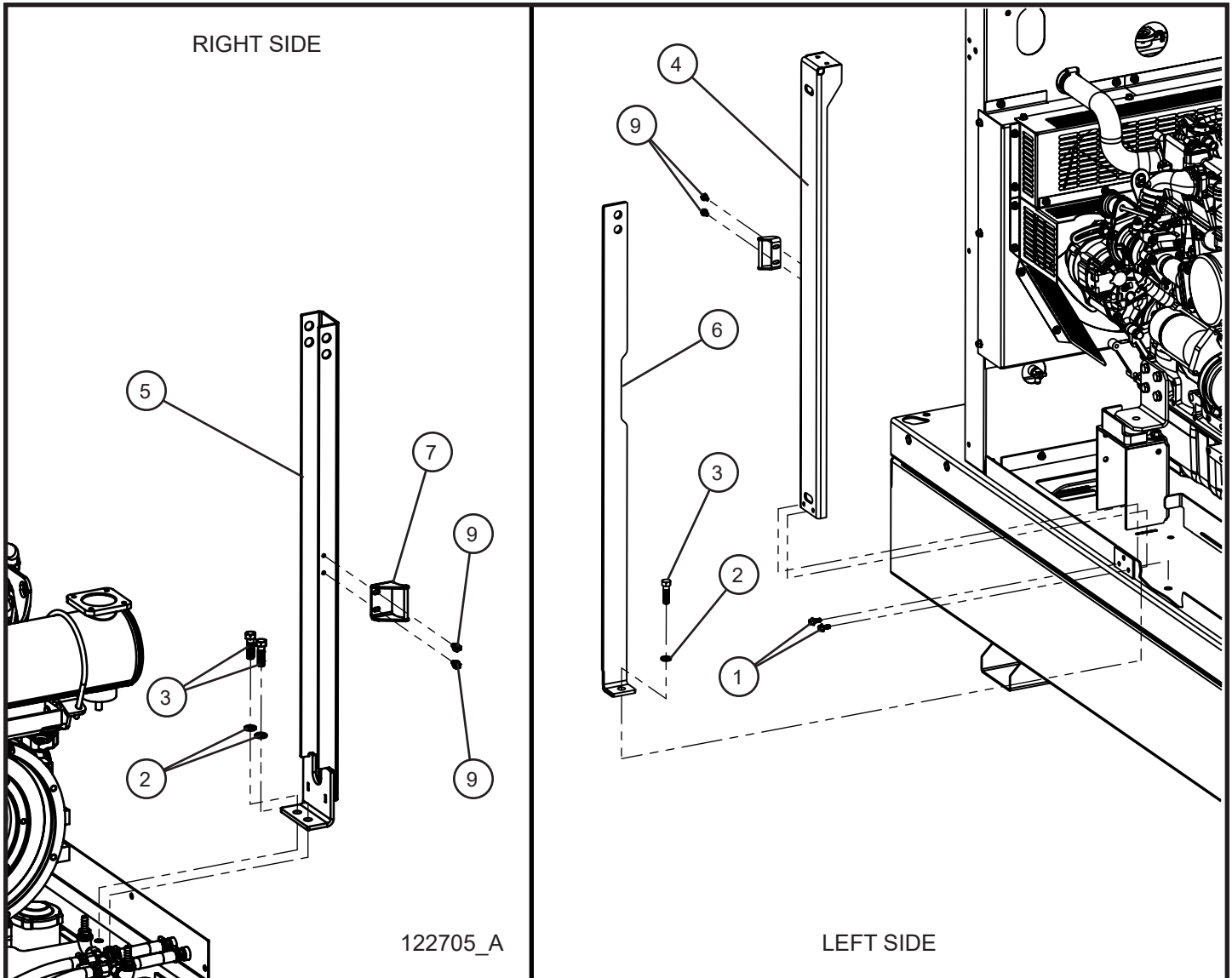

Maxi-Power™ 25

SN 48-000001 and UP

2.10 - Left and Right Side Door Latch Brackets

Item	Part No.	Part Description	Qty.
1	056018	1/4-20 X 5/8 HEX SCREW SERRATED FLANGE	2
2	121912	7/16 SPLITLOCK WASHER	3
3	046160	7/16-14 X 1 1/2 HEX HEAD CS	3
4	118757P	UPRIGHT LATCH BRACKET WELDMENT LH MP25	1
5	118826P	BRACKET WELDMENT RH UPRIGHT LATCH MP25	1
6	118834P	DOOR JAMB LEFT SIDE	1
7	124239P	MP 25 DOOR LATCH BAR WELDMENT	1
8	124241P	MP 25 LH DOOR LATCH BAR WELDMENT	1
9	041073	1/4-20 X 1/2 SL-HEX WASHER HEAD MS	4

NS - Not Shown

* * * - Contact Allmand for more information.

3.1 - Control Panel

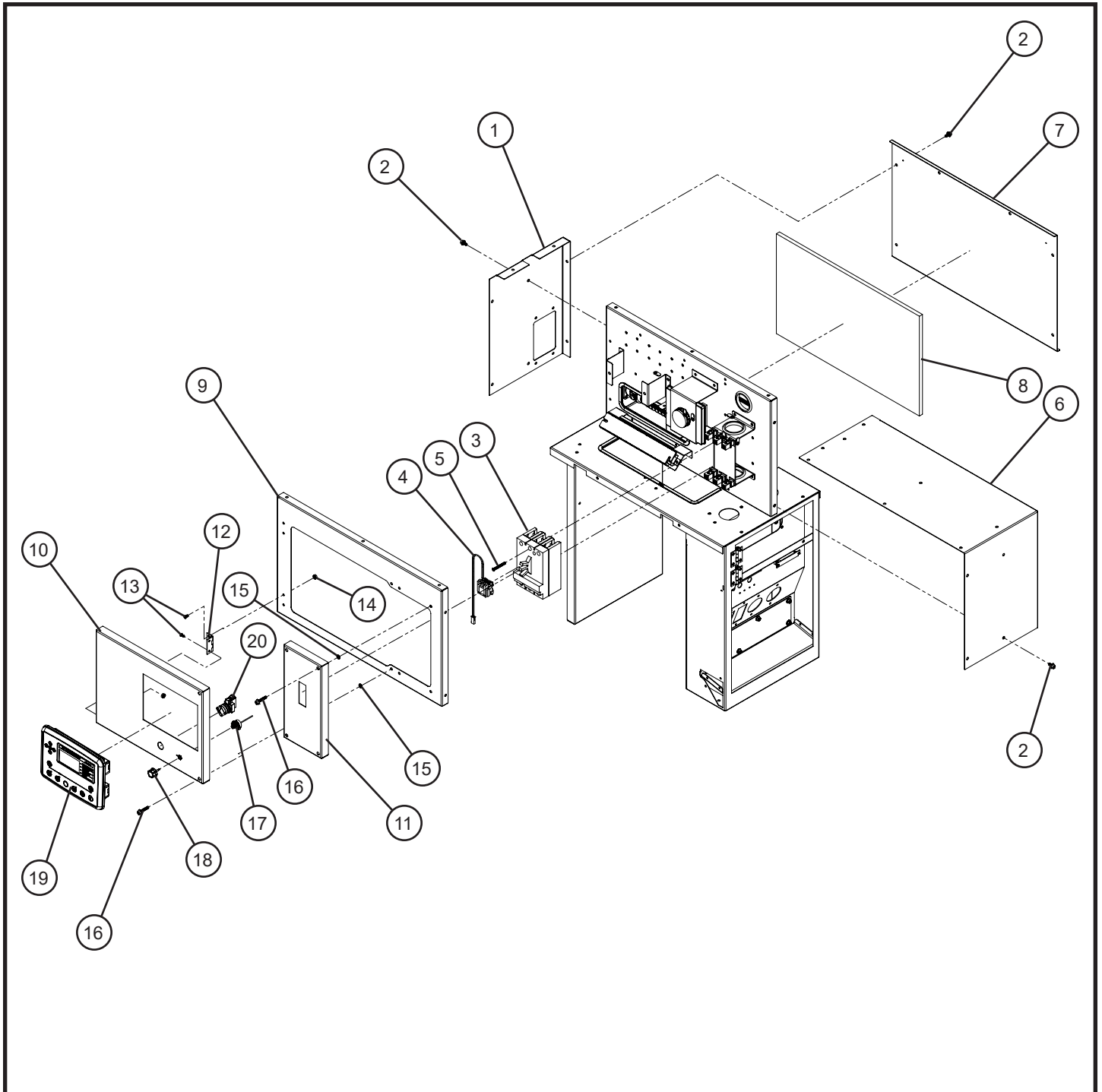

Maxi-Power™ 25

SN 48-000001 and UP

3.1 - Control Panel

Item	Part No.	Part Description	Qty.
1	121196P	CONTROL CABINET, LEFT SIDE PANEL WELDMENT MP25	1
2	056001	1/4-20 x 1/2 HEX SERRATED FLANGE SCREW	43
3	121417	CIRCUIT BREAKER 80A 3P 600V 14kA	1
4	121907	SHUNT TRIP 12V	1
	121862	SHUNT TRIP HARNESS	1
5	121416	#10-24 X 2 3/4 PAN HEAD MS	2
6	121197P	ELECTRICAL CONTROL CABINET TOP PANEL WELDMENT MP25	1
7	118780P	MP25 CABINET BACK COVER	1
8	118794	MP25 BACK COVER FOAM	1
9	121420P	CONTROL CABINET DOOR FRAME WELDMENT MP25	1
10	121413P	WELDMENT CONTROL CABINET DOOR MP25	1
11	120978P	WELDMENT BREAKER COVER PANEL MP25	1
12	122008	STANDARD HINGE #8 HOLE 2.00 X 1.75	2
13	121415	#8-32 X 3/8 PH-FLAT HEAD COUNTERSUNK MS PL	8
14	044003	#8-32 NC KEPS NUT	8
15	101701	1/4 PUSH NUT	6
16	056036	HEX NON-SERRATED FLANGE SCREW 1/4-20 X 1.750	6
17	122156	POTENTIOMETER	1
18	121789	KNOB POTENTIOMETER	1
19	118699	DSE 7310 MKII CONTROL MODULE	1
20	121910	SWITCH CONTROL ON / OFF	1
NS	123581	INSERT BANNER RIGHT SIDE DEEP SEA 7310 MAXI-POWER	1
NS	123580	INSERT BANNER TOP DEEP SEA 7310 MAXI-POWER	1
NS	104743	FUSE JCASE® 60 AMP	1
NS	121861	CONTROL HARNESS MP25	1
NS	121860	ISUZU ENGINE INTERFACE HARNESS MP25	1
NS	122604	JUMPER TERMINAL BLOCK J603	1
NS	122995	VOLTAGE SELECTOR SWITCH TO OUTLET WIRE HARNESS	1
NS	121551	SWITCH WIRE KIT MP25	1
NS	121863	WIRE SCHEMATIC GENERATOR TO OUTLETS MP25	1

NS - Not Shown

*** - Contact Allmand for more information.

3.2 - Control Box Interior

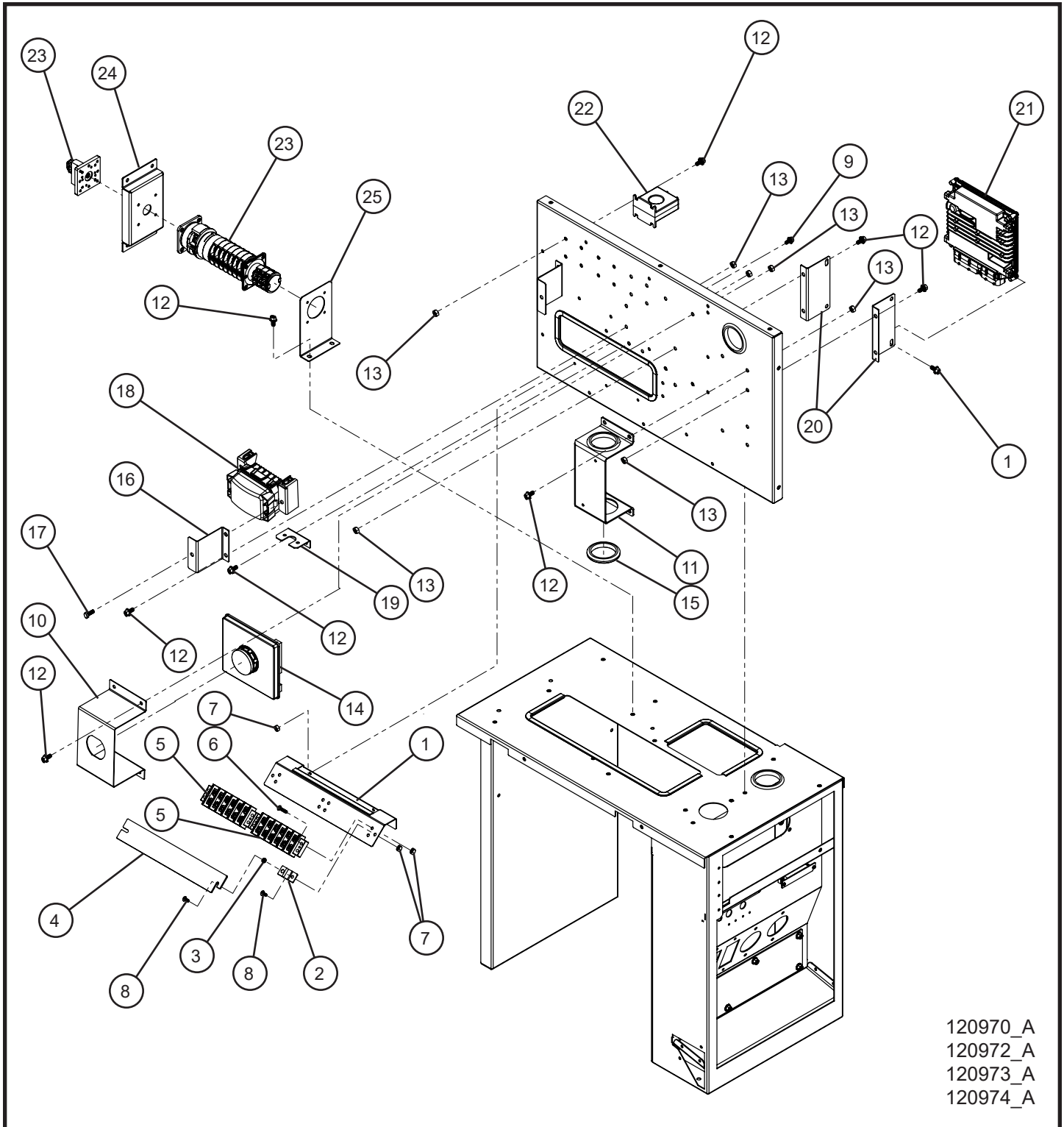

120970_A
120972_A
120973_A
120974_A

Maxi-Power™ 25

SN 48-000001 and UP

3.2 - Control Box Interior

Item	Part No.	Part Description	Qty.
1	124233P	TERMINAL BLOCK MOUNT MP25	1
2	121856	TERMINAL BLOCK COVER MOUNT MP25	2
3	121336	#10-24 LOW-PROFILE RIVNUT	2
4	124234	TERMINAL STRIP COVER MP25	1
5	123159	TERMINAL STRIP 6 POSITION TB400 SERIES	2
6	121711	#10-24 X 3/4" PH-PAN HEAD MS	8
7	044016	#10-24 KEPS HEX NUT	15
8	121700	#10-24 x 3/8" PH-PAN HEAD MS	4
9	056016	#10-24 x 3/8 SERRATED FLANGE HEX BOLT	3
10	121294P	AVR RISER BRACKET	1
11	118788P	MP25 MAIN BREAKER STANDOFF	1
12	056001	1/4-20 x 1/2 HEX SERRATED FLANGE SCREW	43
13	044021	1/4-20 KEPS HEX NUT	25
14	123175	MARATHON GENERATOR 282PSL1750 AVR BOARD ASSEMBLY	1
15	121702	GROMMET 2-1/4" 1/8" MATERIAL THK	5
16	121703P	POWER DISTRIBUTION MOUNTING BRACKET 25 45	2
17	042019	M6 x 1.0mm x 16mm HEX HEAD CS	2
18	121860	ISUZU ENGINE INTERFACE HARNESS MP25	1
19	118893P	BARAMETRIC PRESSURE SENSOR BRACKET	1
20	118786P	ECU BRACKET 25 45	2
21	***	ENGINE CONTROL MODULE (ECM)	1
22	118795	100:5 CURRENT TRANSFORMER	3
23	121793	VOLTAGE SELECTOR SWITCH MP25	1
24	121217P	PANEL VOLTAGE SELECTOR SWITCH	1
25	121705P	VOLTAGE SELECTOR SUPPORT BRACKET	1
NS	121918	PADLOCK	1
NS	121861	CONTROL HARNESS MP25	1
NS	104743	FUSE JCASE® 60 AMP	1
NS	***	BAROMETRIC PRESSURE SENSOR	1
NS	122456	DECAL ELECTRICAL WIRING INFORMATION	1
NS	123162	DECAL MAXI-POWER 25 CONTROL BOX 2/6 BLOCK TERMINAL	1
NS	122604	JUMPER TERMINAL BLOCK J603	1
NS	122995	VOLTAGE SELECTOR SWITCH TO OUTLET WIRE HARNESS	1
NS	121551	SWITCH WIRE KIT MP25	1
NS	121863	WIRE SCHEMATIC GENERATOR TO OUTLETS MP25	1

NS - Not Shown

*** - Contact Allmand for more information.

3.3 - Isuzu Engine Interface Harness Fuse Box

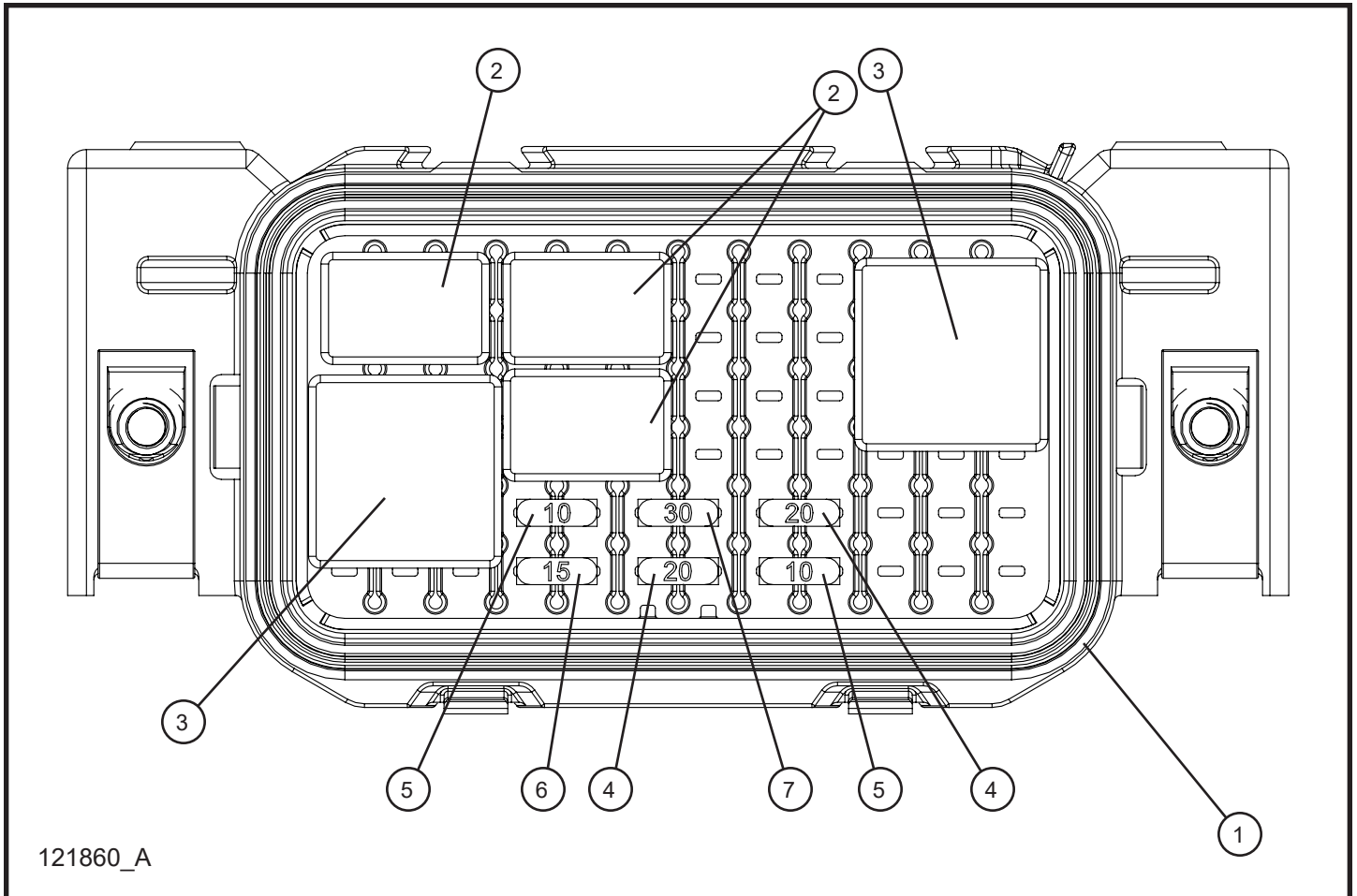

121860_A

Maxi-Power™ 25

SN 48-000001 and UP

3.3 - Isuzu Engine Interface Harness Fuse Box

Item	Allmand No.	Part Description	Qty.
--	121860	ISUZU ENGINE INTERFACE HARNESS MP25	1
1	121575	72 PIN BOARD MODULE	1
2	107928	35 AMP SPST RELAY	3
3	105202	50 AMP SPST RELAY	2
4	105870	20A MINI FUSE	2
5	118358	10A MINI FUSE	2
6	105844	15A MINI FUSE	1
7	107929	30A MINI FUSE	1
NS	104743	FUSE JCASE® 60 AMP	1

NS - Not Shown

* * * - Contact Allmand for more information.

3.4 - Connection Lug and Outlet Panel I

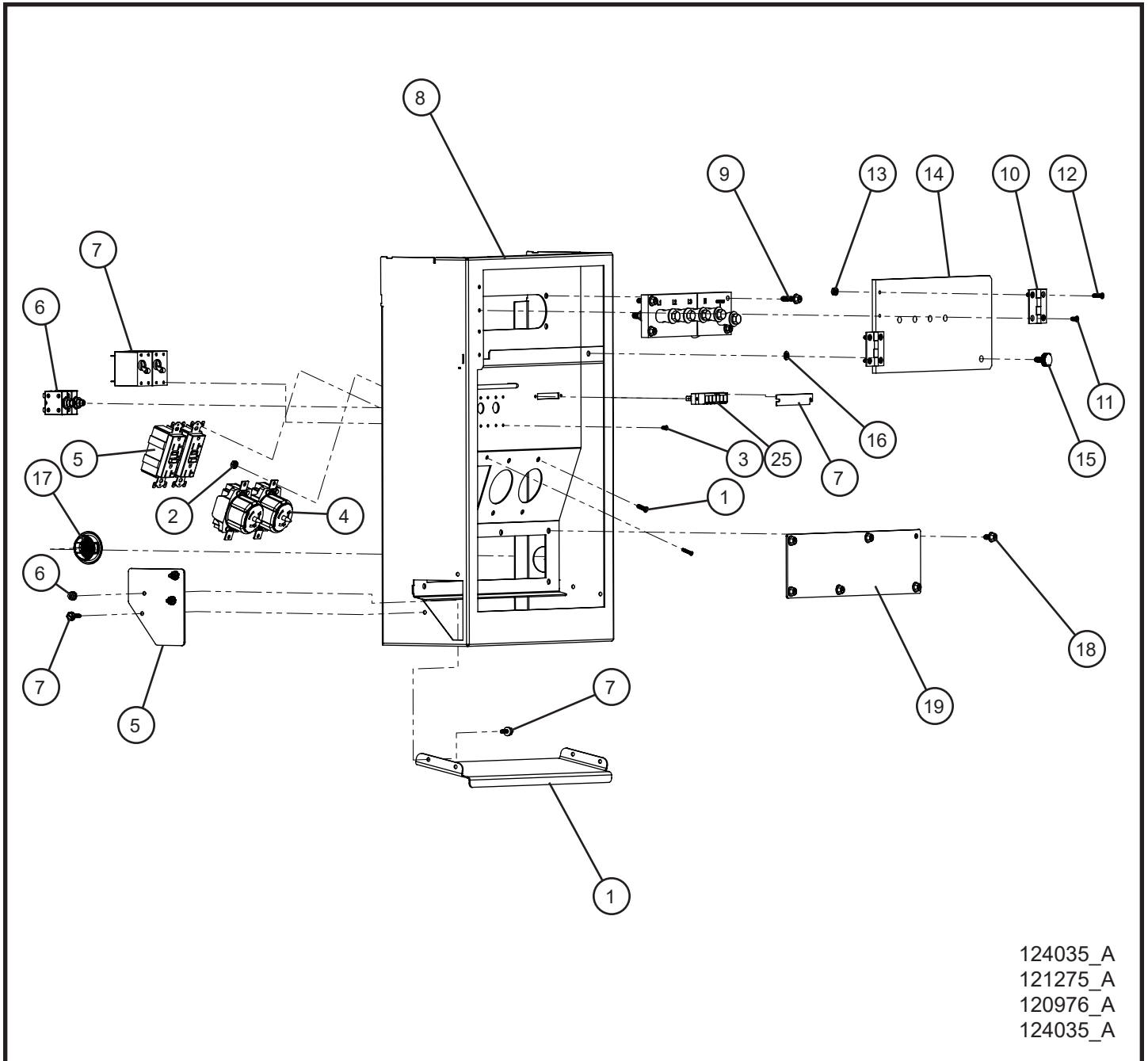

124035_A
121275_A
120976_A
124035_A

Maxi-Power™ 25

SN 48-000001 and UP

3.4 - Connection Lug and Outlet Panel I

Item	Part No.	Part Description	Qty.
1	041021	#10-24 X 1/2 PH-ROUND HEAD MS	4
2	044016	#10-24 KEPS HEX NUT PL	4
3	041018	#6-32 X 1/4 PH-ROUND HEAD MS PL	8
4	104267	CS6369 RECEPTACLE 50 AMP 125/250 VOLT 4 WIRE	2
5	330499	RECEPTACLE GFCI 20 AMP	2
6	118398	BREAKER THERMAL PUSH BUTTON 20A CSA APPROVED	2
7	353279	50A DPST CIRCUIT BREAKER	2
8	121194P	ELECTRICAL CONNECTION SIDE PANEL WELDMENT	1
9	056017	1/4-20 X 1 SERRATED FLANGE HEX BOLT	4
10	122008	STANDARD HINGE #8 HOLE 2.00 X 1.75	2
11	121415	#8-32 X 3/8 PH-FLAT HEAD COUNTERSUNK MS	4
12	121414	#8-32 X 5/8 PH-FLAT HEAD COUNTERSUNK MS	4
13	044003	#8-32 NC KEPS NUT	8
14	118783	ECC CONNECTION BASE CLEAR COVER MP25	1
15	121271	1/4-20 X 5/8 PLASTIC-HEAD THUMB SCREW	1
16	101701	1/4 PUSH NUT	1
17	122005	LIQUID TITE BREAK-THRU PLUG	1
18	056001	1/4-20 X 1/2 HEX SERRATED FLANGE SCREW	6
19	121193P	CAM LOCK BLANK COVER PLATE MP25	1
20	056005	#10-24 X 3/4 SERRATED FLANGE HEX SCREW	5
21	057004	#10-24 SERRATED FLANGE HEX NUT	5
22	124033P	CONTROL BOX LOWER PLATE MP 25	1
23	124068P	SIDE COVER CONTROL CABINET MP 25	1
24	041070	1/4-20 X 3/4 SL-HEX WASHER HEAD MS	1
25	121783	CONN BERRIER TERMINAL STRIP 6 POSITION	1
26	121841	TERMINAL STRIP COVER OUTLET PANEL	1
NS	118782P	MP 25 ECC CONNECTION BASE BACK COVER	1
NS	122079	DECAL OUTLET PANEL MAXI-POWER 25	1
NS	122084	DECAL ELECTRICAL WIRING INFORMATION	1
NS	122995	VOLTAGE SELECTOR SWITCH TO OUTLET WIRE HARNESS	1
NS	121552	OUTLET WIRE KIT MP25	1
NS	121863	WIRE SCHEMATIC GENERATOR TO OUTLETS MP25	1

NS - Not Shown

*** - Contact Allmand for more information.

3.5 - Connection Lug and Outlet Panel II

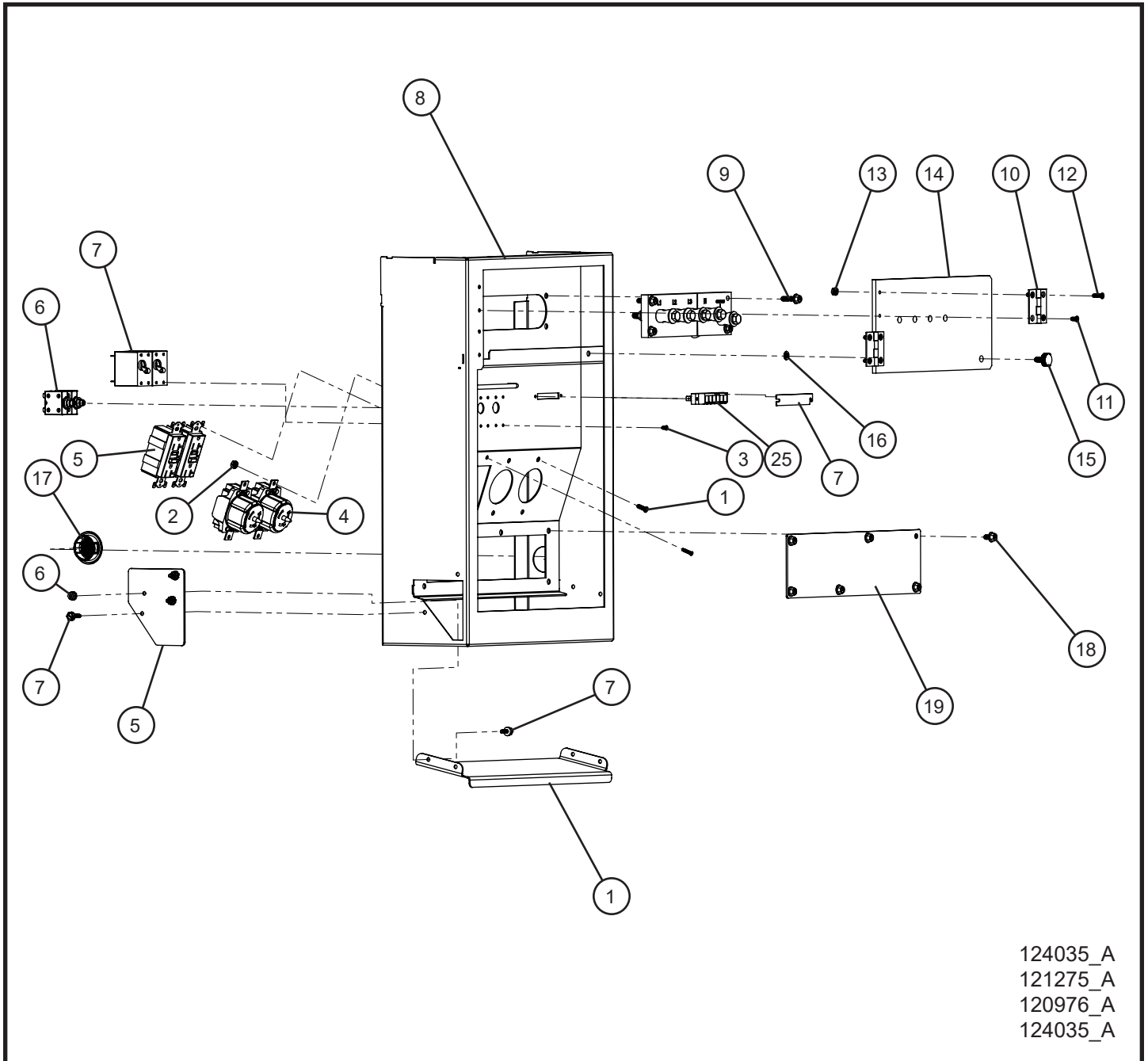

Maxi-Power™ 25

SN 48-000001 and UP

3.5 - Connection Lug and Outlet Panel II

Item	Part No.	Part Description	Qty.
1	041021	#10-24 X 1/2 PH-ROUND HEAD MS	4
2	044016	#10-24 KEPS HEX NUT PL	4
3	041018	#6-32 X 1/4 PH-ROUND HEAD MS PL	8
4	104267	CS6369 RECEPTACLE 50 AMP 125/250 VOLT 4 WIRE	2
5	330499	RECEPTACLE GFCI 20 AMP	2
6	118398	BREAKER THERMAL PUSH BUTTON 20A CSA APPROVED	2
7	123261	50AMP DOUBLE POLE CIRCUIT BREAKER	2
8	124488P	ELECTRICAL OUTLET SIDE PANEL WELDMENT BSB MP25	1
9	056017	1/4-20 X 1 SERRATED FLANGE HEX BOLT	4
10	122008	STANDARD HINGE #8 HOLE 2.00 X 1.75	2
11	121415	#8-32 X 3/8 PH-FLAT HEAD COUNTERSUNK MS	4
12	121414	#8-32 X 5/8 PH-FLAT HEAD COUNTERSUNK MS	4
13	044003	#8-32 NC KEPS NUT	8
14	118783	ECC CONNECTION BASE CLEAR COVER MP25	1
15	121271	1/4-20 X 5/8 PLASTIC-HEAD THUMB SCREW	1
16	101701	1/4 PUSH NUT	1
17	122005	LIQUID TITE BREAK-THRU PLUG	1
18	056001	1/4-20 X 1/2 HEX SERRATED FLANGE SCREW	6
19	121193P	CAM LOCK BLANK COVER PLATE MP25	1
20	056005	#10-24 X 3/4 SERRATED FLANGE HEX SCREW	5
21	057004	#10-24 SERRATED FLANGE HEX NUT	5
22	124033P	CONTROL BOX LOWER PLATE MP 25	1
23	124068P	SIDE COVER CONTROL CABINET MP 25	1
24	041070	1/4-20 X 3/4 SL-HEX WASHER HEAD MS	1
25	121783	CONN BERRIER TERMINAL STRIP 6 POSITION	1
26	121841	TERMINAL STRIP COVER OUTLET PANEL	1
NS	118782P	MP 25 ECC CONNECTION BASE BACK COVER	1
NS	122079	DECAL OUTLET PANEL MAXI-POWER 25	1
NS	122084	DECAL ELECTRICAL WIRING INFORMATION	1
NS	122995	VOLTAGE SELECTOR SWITCH TO OUTLET WIRE HARNESS	1
NS	121552	OUTLET WIRE KIT MP25	1
NS	121863	WIRE SCHEMATIC GENERATOR TO OUTLETS MP25	1

NS - Not Shown

*** - Contact Allmand for more information.

3.6 - Connection Lug Plate

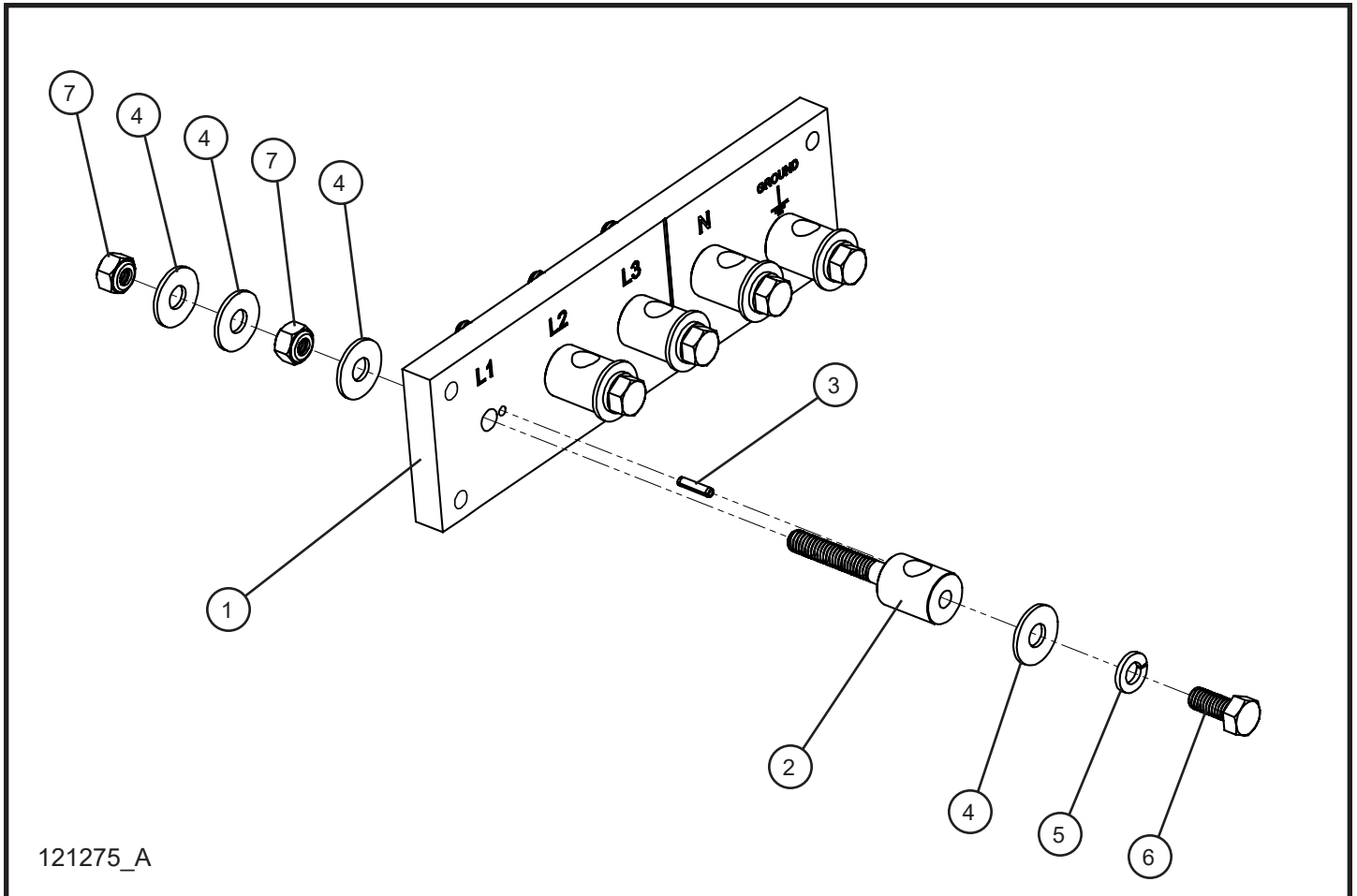

121275_A

Maxi-Power™ 25

SN 48-000001 and UP

3.6 - Connection Lug Plate

Item	Allmand No.	Part Description	Qty.
1	118790	ECC CONNECTION BASE LUG INSULATOR PLATE MP25	1
2	118872	MP25 ECC CONNECTION BASE CABLE LUG	5
3	118874	1/8 X 9/16 SPRING ROLL PIN	5
4	047010	5/16 FLAT WASHER PL	20
5	043055	5/16 SPLITLOCK WASHER	5
6	046045	5/16-18 X 3/4 HEX HEAD CS	5
7	044033	5/16-18 NYLOCK HEX NUT	10

NS - Not Shown

* * * - Contact Allmand for more information.

3.7 - Camlocks

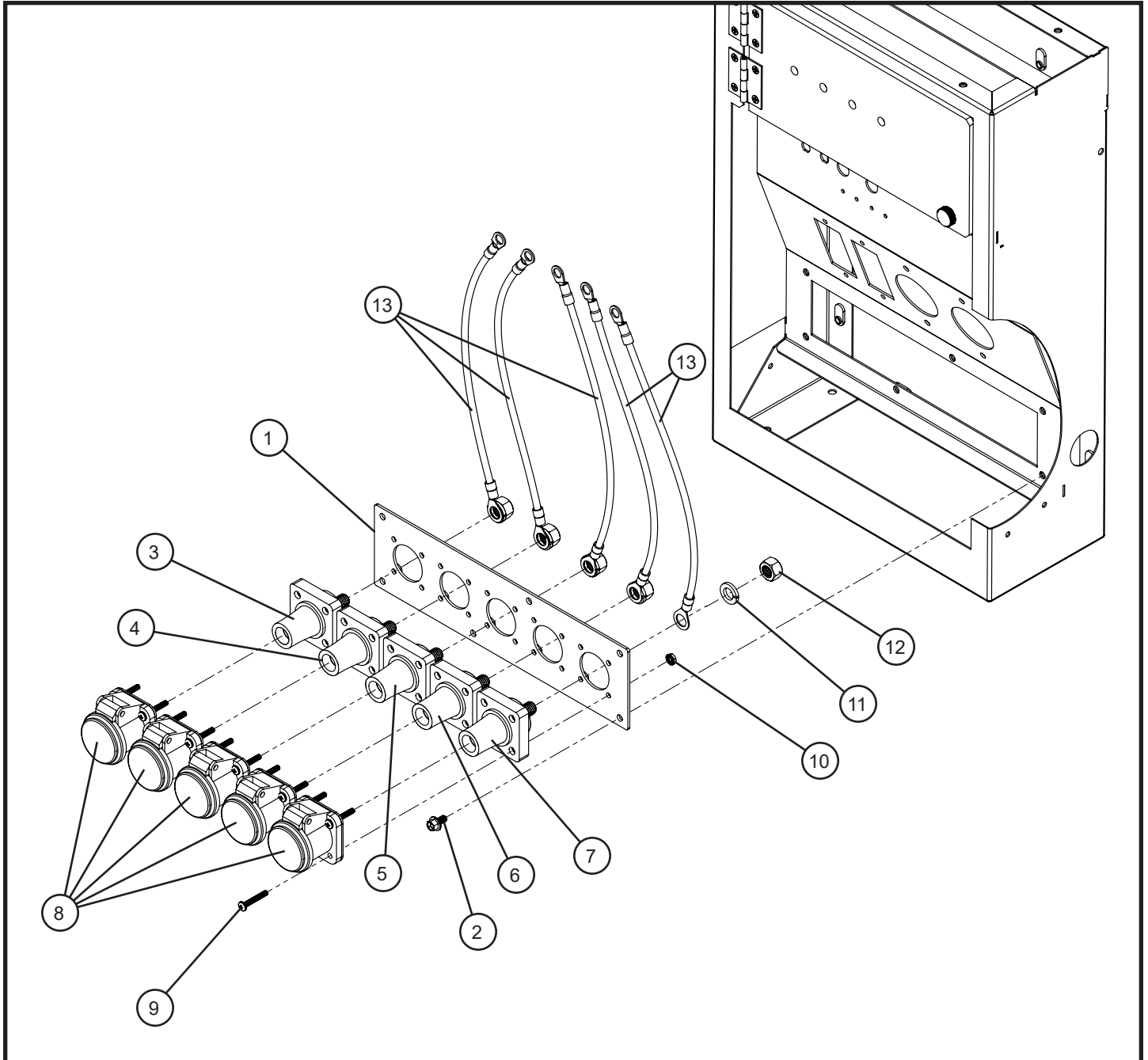

Maxi-Power™ 25

SN 48-000001 and UP

3.7 - Camlocks

Item	Allmand No.	Part Description	Qty.
1	124066P	CAM LOCK PLATE MP25	1
2	056001	1/4-20 X 1/2 HEX SERRATED FLANGE SCREW	6
3	113242	CAM LOCK BLACK FEMALE 90° 600V 400A	1
4	113243	CAM LOCK RED FEMALE 90° 600V 400A	1
5	113244	CAM LOCK BLUE FEMALE 90° 600V 400A	1
6	113245	CAM LOCK WHITE FEMALE 90° 600V 400A	1
7	113246	CAM LOCK GREEN FEMALE 90° 600V 400A	1
8	112424	CAM LOCK CLEAR COVER 90°	5
9	041035	#10-24 x 1-1/4 PHILLIPS MACHINE SCREW	20
10	044016	#10-24 KEPS HEX NUT	20
11	043085	1/2 SPLITLOCK WASHER	5
12	044045	1/2-13 HEX NUT	5
13	116719	CAM LOCK CABLE KIT 8 AWG MP 25	1
NS	112136	DECAL CAM LOCKS	1
NS	112422	CAM LOCK 1/0 CABLE SCHEMATIC	1

NS - Not Shown

*** - Contact Allmand for more information.

4.1 - Isuzu 4LE2T Engine Assembly Group (1 of 3)

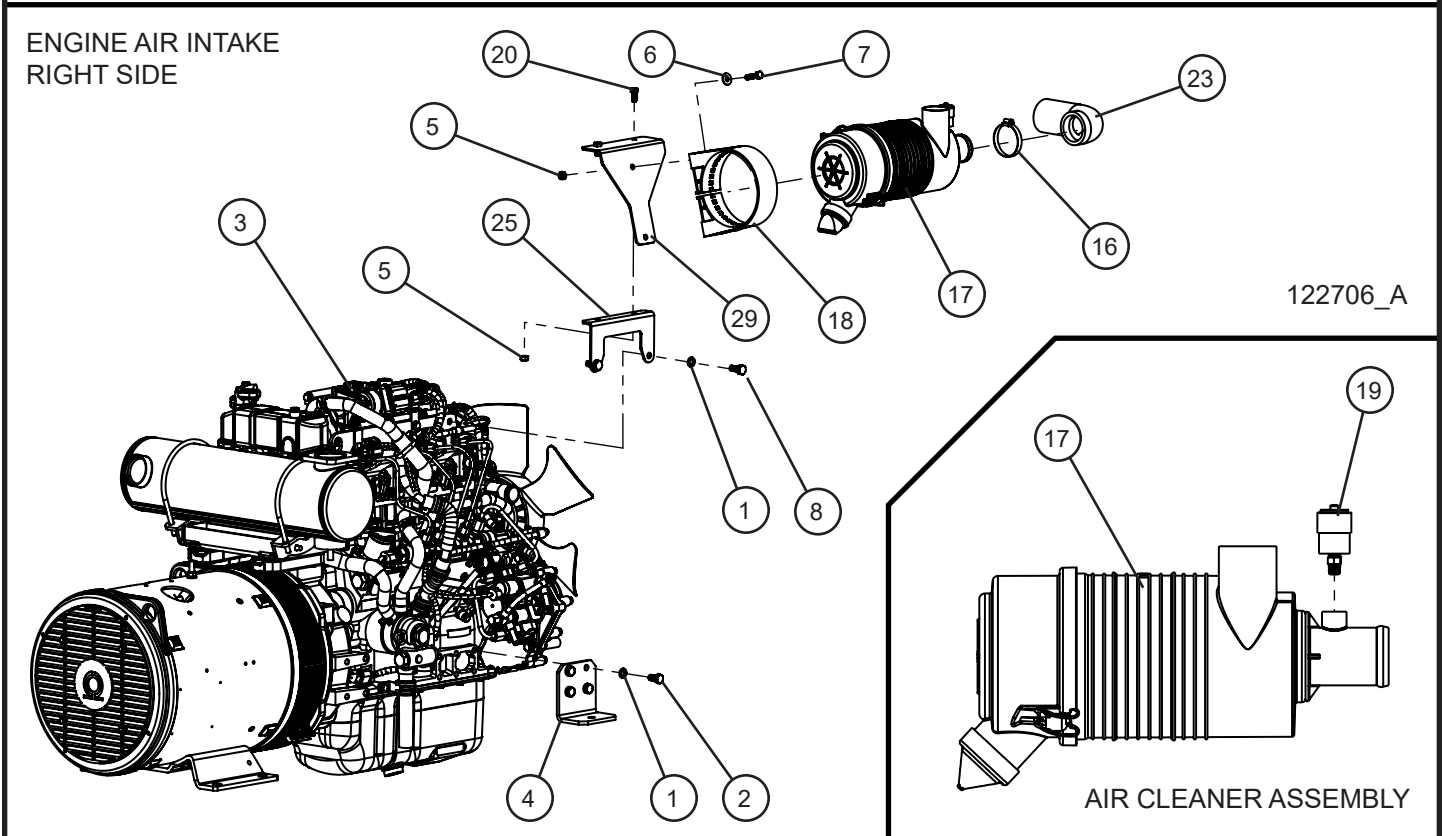
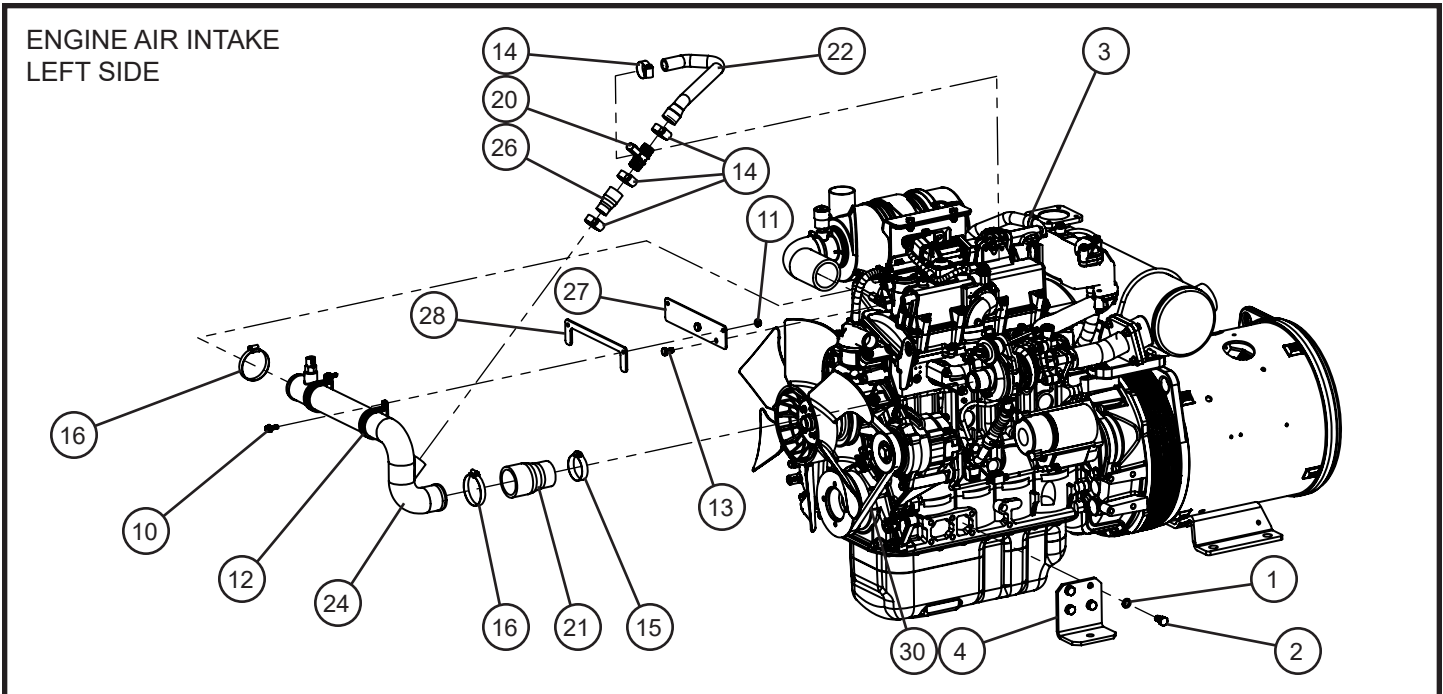

Maxi-Power™ 25

SN 48-000001 and UP

4.1 - Isuzu 4LE2T Engine Assembly Group (1 of 3)

Item	Part No.	Part Description	Qty.
1	042151	M10 SPLITLOCK WASHER	24
2	042037	M10 x 20mm x 1.5mm HEX HEAD BOLT	24
3	122011	ISUZU 4LE2T ENGINE MP SPEC	1
4	118741P	BRACKET ENGINE MOUNT MP25	2
5	042081	M8 X 1.25mm NYLOCK HEX NUT	4
6	047010	5/16 FLAT WASHER	2
7	046055	5/16-18 X 1 1/4 HEX HEAD BOLT	2
8	102130	M10 x 35mm x 1.25mm HEX HEAD BOLT	2
9	046045	5/16-18 X 3/4 HEX HEAD BOLT	2
10	056002	1/4-20 x 3/4 HEX SERRATED FLANGE SCREW	2
11	057001	1/4-20 HEX NYLOCK FLANGE NUT	2
12	022008	#32 CUSHION CLAMP 1/4 HOLE	2
13	042027	M8 x 16mm x 1.25mm HEX HEAD BOLT	2
14	045032	#12 HOSE CLAMP	4
15	045036	#24 HOSE CLAMP	1
16	045038	#32 HOSE CLAMP	3
17	104061	DONALDSON AIR CLEANER ASSEMBLY	1
	15-000125	PRIMARY FILTER	1
	104071	SAFETY FILTER	1
18	921140	AIR CLEANER BAND MOUNT	1
19	104795	AIR FILTER SERVICE INDICATOR KIT	1
20	106943	HEATER PCV	1
21	106987	2.00 to 1.50 ISUZU 4LE2T AIR INTAKE ADAPTER	1
22	107117	ISUZU 4LE2T PCV HOSE	1
23	121097	MP 25 ISUZU 4LE2T 90° INTAKE HOSE ELBOW	1
24	106254	ISUZU 4LE2T STEEL TUBE AIR INTAKE	1
25	121096P	AIR CLEANER BRACKET ISUZU 4LE2 MP25	1
26	107121	ISUZU 4LE2T PCV HOSE REDUCER	1
27	107009P	ISUZU 4LE2T INTAKE SUPPORT BRACKET	1
28	107011P	ISUZU 4LE2T INTAKE SUPPORT SPACER	1
29	121234P	AIR CLEANER BRACKET ISUZU 4LE2 MP25	1
30	111649	FAN BELT	1
NS	104743	FUSE JCASE® 60 AMP	1
NS	115155	CHARGE CIRCUIT FUSE HOLDER	1

NS - Not Shown

*** - Contact Allmand for more information.

©2022 Briggs & Stratton®

4.1 - Isuzu 4LE2T Engine Assembly Group (2 of 3)

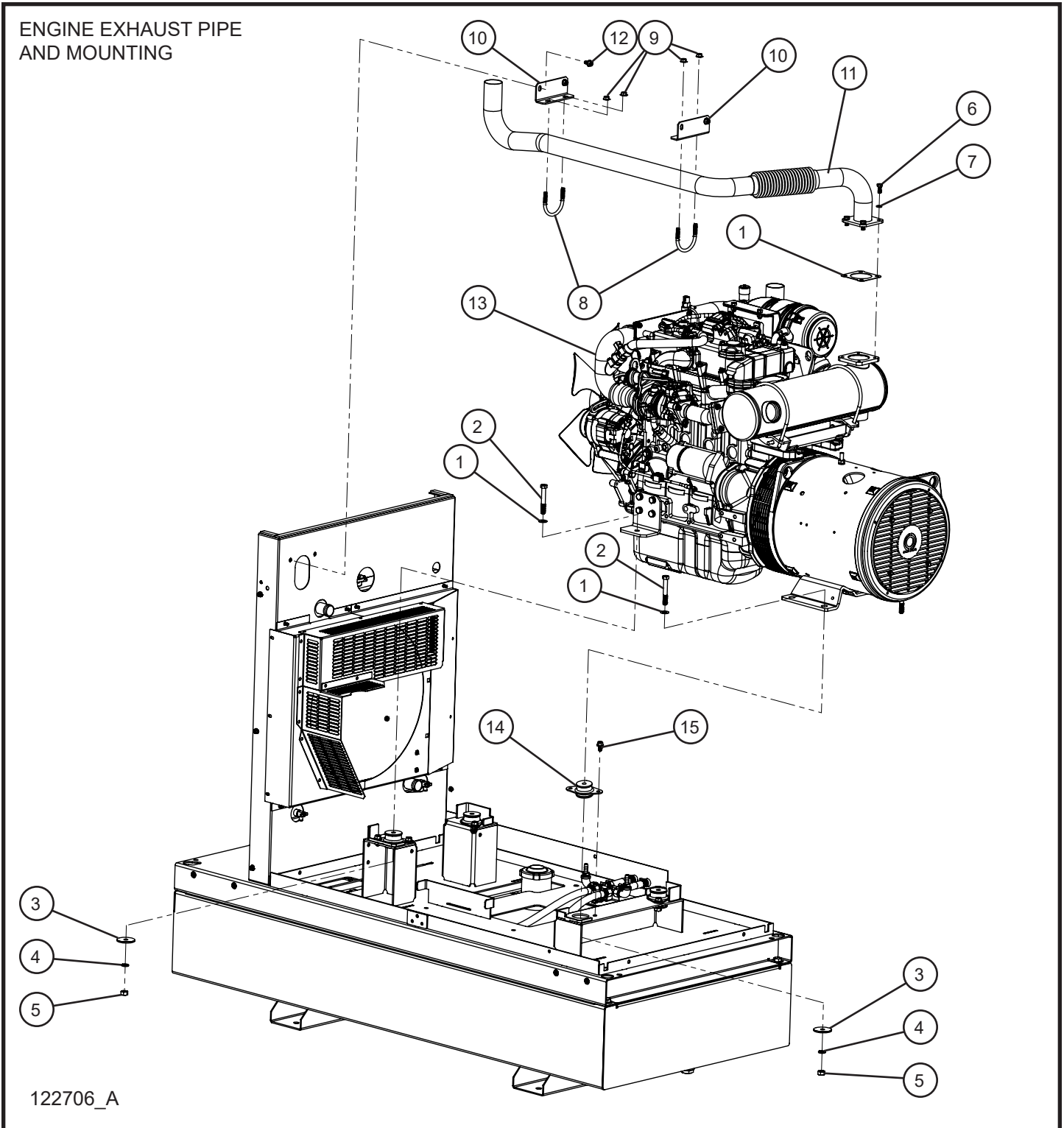

Maxi-Power™ 25

SN 48-000001 and UP

4.1 - Isuzu 4LE2T Engine Assembly Group (2 of 3)

Item	Part No.	Part Description	Qty.
1	047020	7/16 FLAT WASHER	4
2	121915	7/16-14 x 3 HEX HEAD BOLT	4
3	650260	WASHER 2 OD X .451 ID X .125 THK	4
4	121912	7/16 SPLITLOCK WASHER	4
5	121913	7/16-14 HEX NUT	4
6	042033	M8 x 20mm x 1.25mm HEX HEAD BOLT	4
7	043055	5/16 SPLITLOCK WASHER	4
8	121655	U-BOLT 2.0 PIPE	1
9	057006	5/16-18 SERRATED FLANGE NUT	2
10	118742P	BRACKET EXHAUST PIPE MOUNT	1
11	118740	EXHAUST ISUZU 4LE2T MP25	1
12	121920	5/16-18 X 5/8 SERRATED FLANGE HEX SCREW	2
13	122011	ISUZU 4LE2T ENGINE MP SPEC	1
14	121254	MOTOR ISOLATOR MOUNT	4
15	056009	3/8-16 X 3/4 SERRATED FLANGE HEX SCREW	8

NS - Not Shown

*** - Contact Allmand for more information.

4.1 - Isuzu 4LE2T Engine Assembly Group (3 of 3)

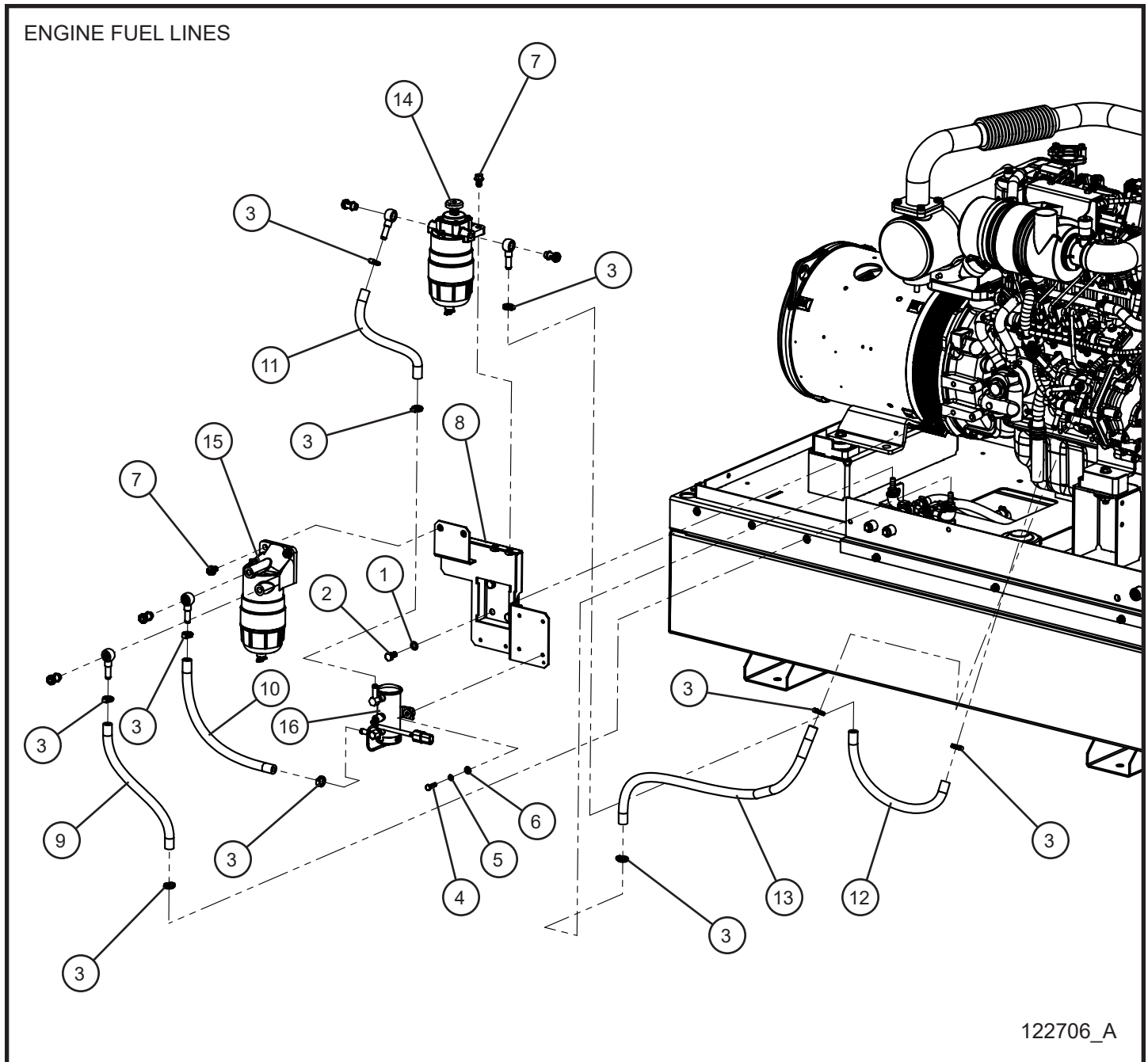

Maxi-Power™ 25

SN 48-000001 and UP

4.1 - Isuzu 4LE2T Engine Assembly Group (3 of 3)

Item	Part No.	Part Description	Qty.
1	047020	7/16 FLAT WASHER	4
2	121915	7/16-14 x 3 HEX HEAD BOLT	4
3	433400	#4 HOSE CLAMP	10
4	046015	1/4-20 X 1 HEX HEAD BOLT	2
5	043020	1/4 SPLITLOCK WASHER	5
6	047005	1/4 FLAT WASHER	2
7	056000	3/8-16 X 5/8 HEX FLANGE SCREW 1 1/4	4
8	121497P	BRACKET-WELDMENT FUEL FILTER MP25-MP45	1
9	101266	3/8 FUEL HOSE X 13.50	1
10	101266	3/8 FUEL HOSE X 14.63	1
11	101266	3/8 FUEL HOSE X 11.06	1
12	101266	3/8 FUEL HOSE X 15.00	1
13	101266	3/8 FUEL HOSE X 30.00	1
14	111647	MAIN FUEL FILTER	1
15	111648	PRE FUEL FILTER	1
16	113008	ELECTRIC FUEL PUMP	1

NS - Not Shown

*** - Contact Allmand for more information.

4.2 - Isuzu 4LE2T Remote Oil Filter

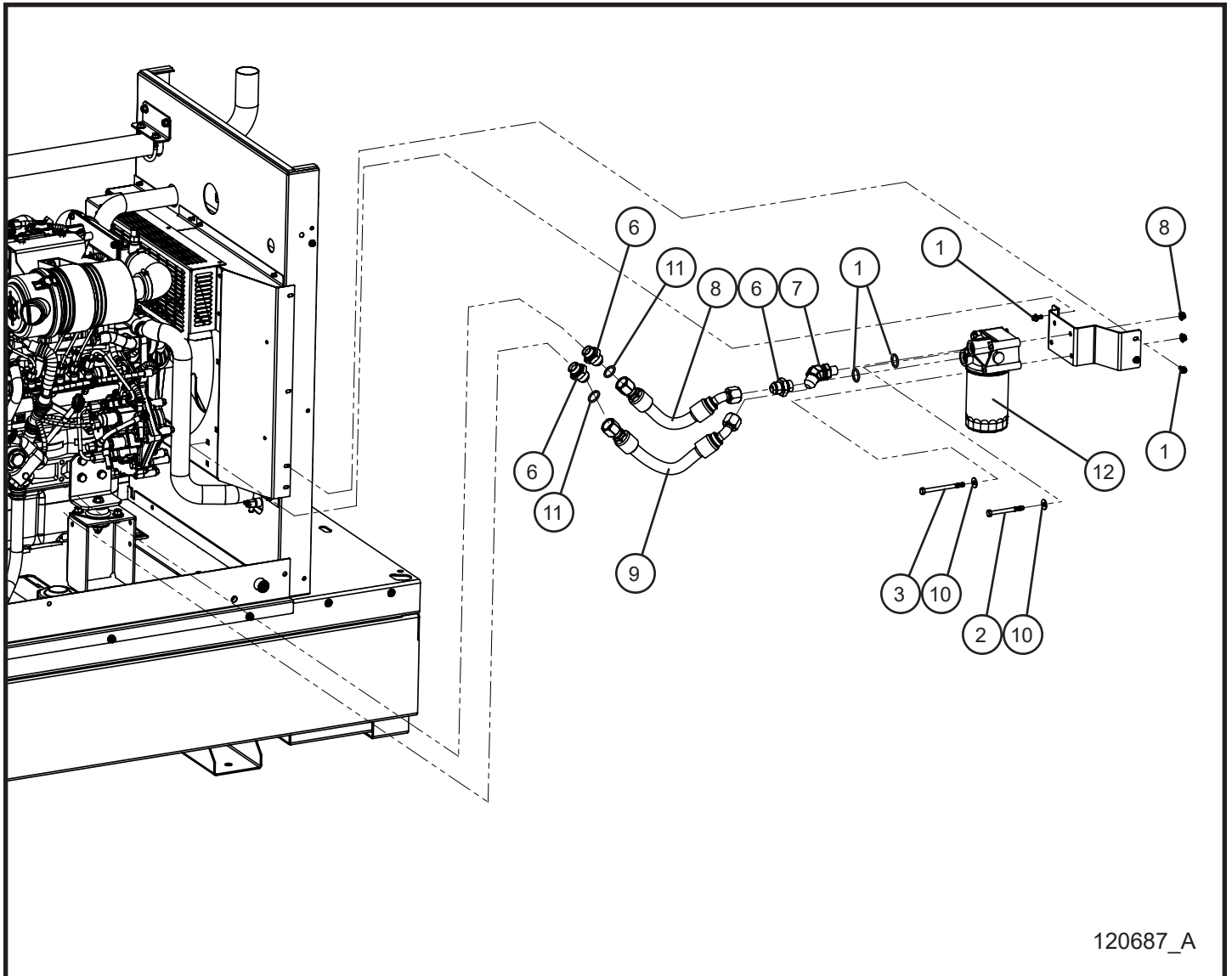

120687_A

Maxi-Power™ 25

SN 48-000001 and UP

4.2 - Isuzu 4LE2T Remote Oil Filter

Item	Part No.	Part Description	Qty.
1	056018	1/4-20 X 5/8 HEX SCREW SERRATED FLANGE	4
2	046076	5/16-18 X 3 1/4 HEX HEAD BOLT	2
3	046079	5/16-18 X 4 HEX HEAD BOLT	2
4	121919P	BRACKET REMOTE OIL FILTER MOUNT	1
5	057006	5/16-18 SERRATED FLANGE NUT	4
6	124424	12F4OMXS TRIPLE LOK BSPP ORR	3
7	124425	9058 12 12 M JIC X M M BSPP 45 ELBOW	1
8	124426	MP25 REMOTE OIL FILTER FEED LINE	1
9	124427	MP25 REMOTE OIL FILTER RETURN LINE	1
10	047010	5/16 FLAT WASHER	4
11	123288	O-RING ISUZU REMOTE OIL	4
12	***	ISUZU OIL FILTER	1

NS - Not Shown

*** - Contact Allmand for more information.

4.3 - Isuzu 4LE2T Remote Oil Drain

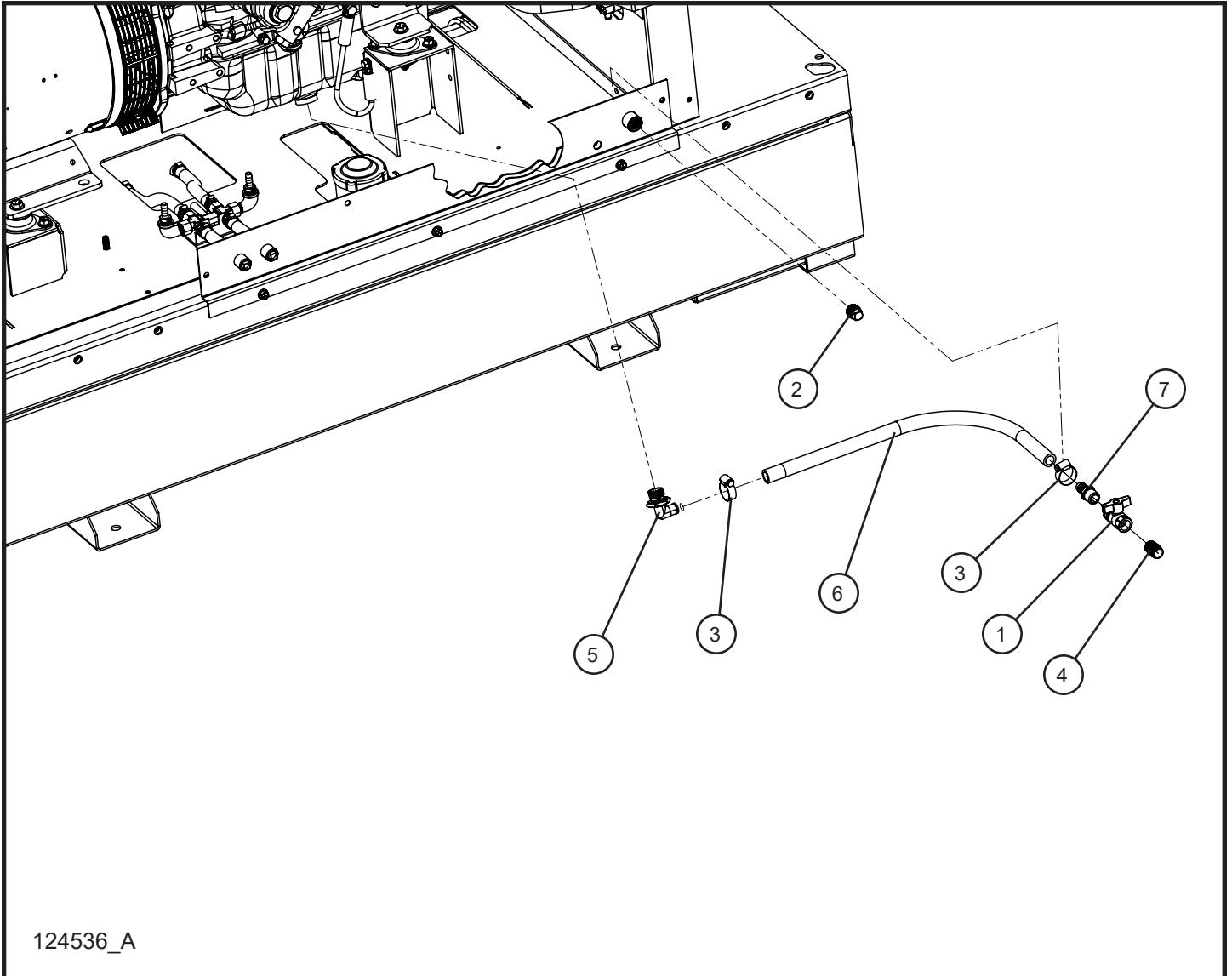

Maxi-Power™ 25

SN 48-000001 and UP

4.3 - Isuzu 4LE2T Remote Oil Drain

Item	Part No.	Part Description	Qty.
1	104133	1/2 BALL VALVE	1
2	026106	PLUG 1/2 NPT SQUARE HEAD	1
3	045032	#12 HOSE CLAMP	2
4	610215	1/2 NPT NIPPLE	1
5	123560	FITTING 90° ADAPTER M24X2 TO 5/8 IN HOSE BARB	1
6	081040	5/8 PUSH-LOK X 23.00 INCHES	1
7	123561	5/8 X 1/2 MNPT HOSE BARB	1

NS - Not Shown

* * * - Contact Allmand for more information.

4.4 - Isuzu 4LE2T Fan Guards

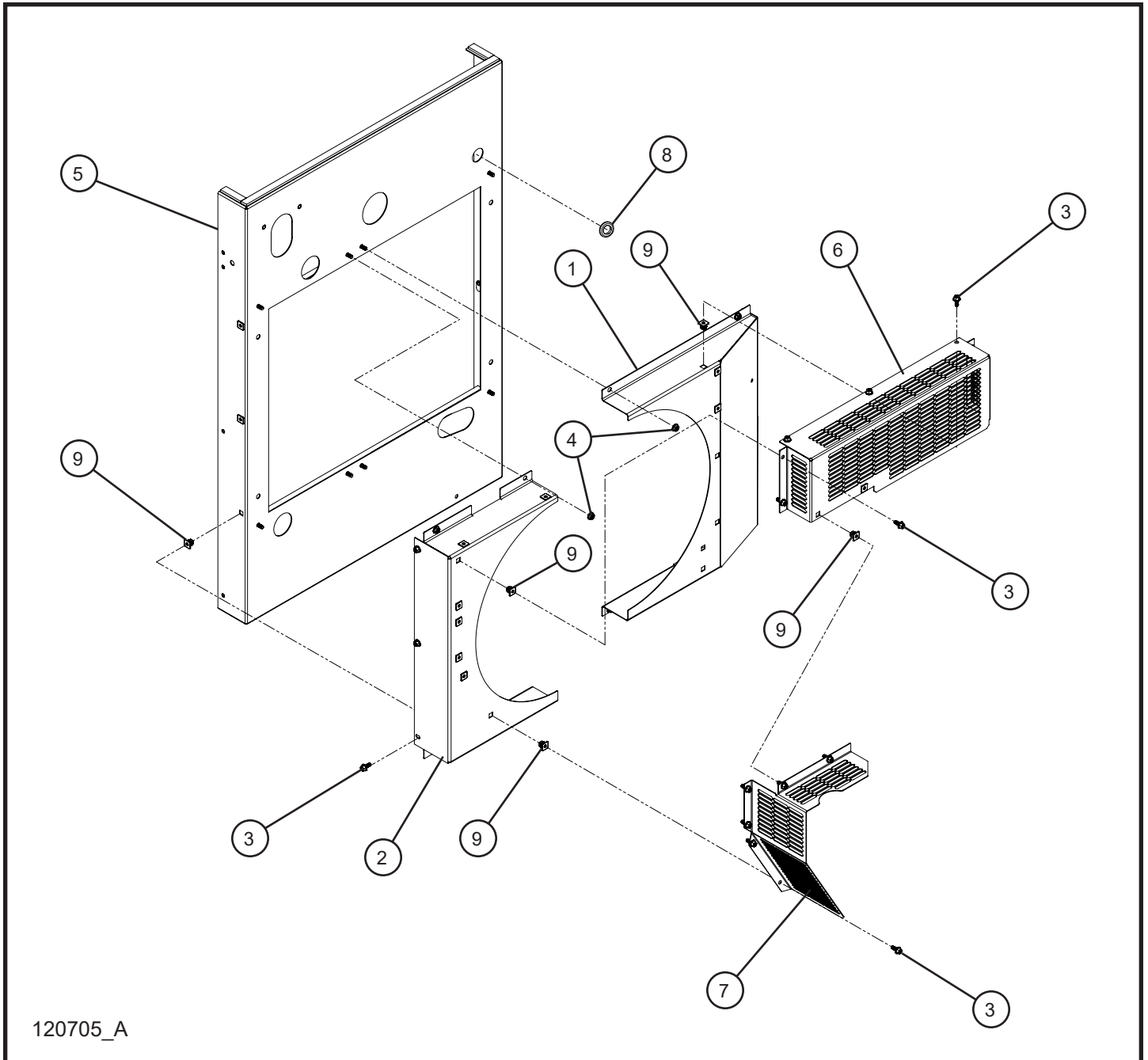

Maxi-Power™ 25

SN 48-000001 and UP

4.4 - Isuzu 4LE2T Fan Guards

Item	Part No.	Part Description	Qty.
1	118843P	FAN SHROUD RIGHT SIDE	1
2	118841P	FAN SHROUD RADIATOR LEFT SIDE MP25	1
3	056018	1/4-20 X 5/8 HEX SCREW SERRATED FLANGE	28
4	057000	1/4-20 HEX SERRATED FLANGE NUT	11
5	118747P	RADIATOR MOUNTING PANEL WELDMENT MP25	1
6	118864P	FAN GUARD UPPER	1
7	118866P	FAN GUARD ANGLED	1
8	122947	GROMMET, 1-7/16 OD X 27/32 ID	1
9	105408	GROMMET NUT DOUBLE SPLIT SQUARE HEAD	24

NS - Not Shown

*** - Contact Allmand for more information.

4.5 - Isuzu 4LE2T Radiator

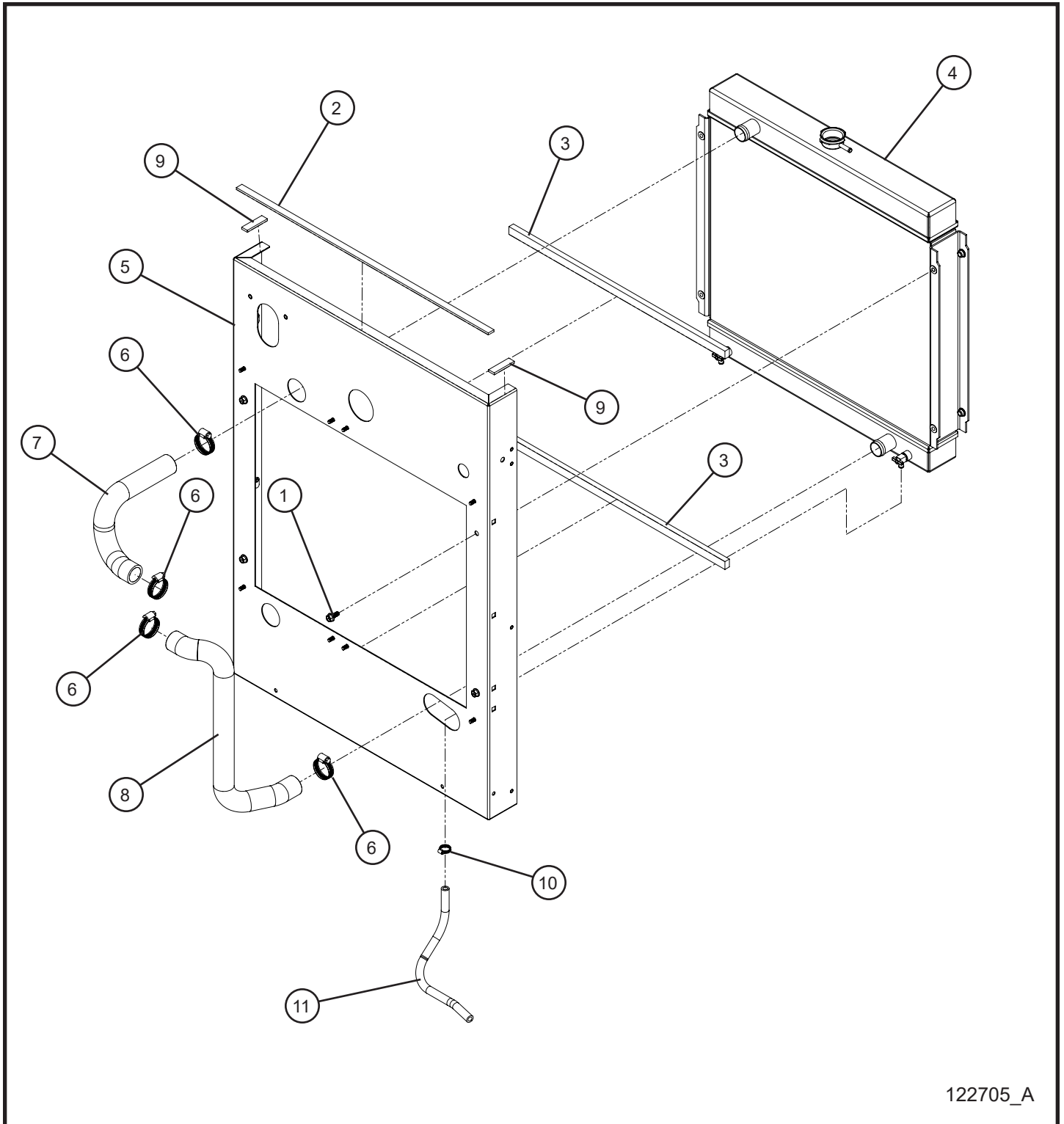

122705_A

Maxi-Power™ 25

SN 48-000001 and UP

4.5 - Isuzu 4LE2T Radiator

Item	Part No.	Part Description	Qty.
1	056038	5/16-18 X 3/4 HEX FLANGE SCREW	4
2	121067	3/16 X 5/8 FOAM STRIP ADHESIVE BACKED X 28.00	1
3	121053	FOAM STRIP .500 X .750 X 24.0 INCHES	2
4	118743	RADIATOR MP25	1
5	118747P	RADIATOR MOUNTING PANEL WELDMENT MP25	1
6	045035	#20 HOSE CLAMP	4
7	118744	RADIATOR HOSE UPPER ISUZU 4LE2T MP25	1
8	118745	RADIATOR HOSE LOWER ISUZU 4LE2T MP25	1
9	121067	3/16 X 5/8 FOAM STRIP ADHESIVE BACKED X 2.25	2
10	433400	#4 HOSE CLAMP	4
11	101266	HOSE 3/8 SAE 30R7 X 15 INCHES	1

NS - Not Shown

*** - Contact Allmand for more information.

4.6 - Coolant Reservoir

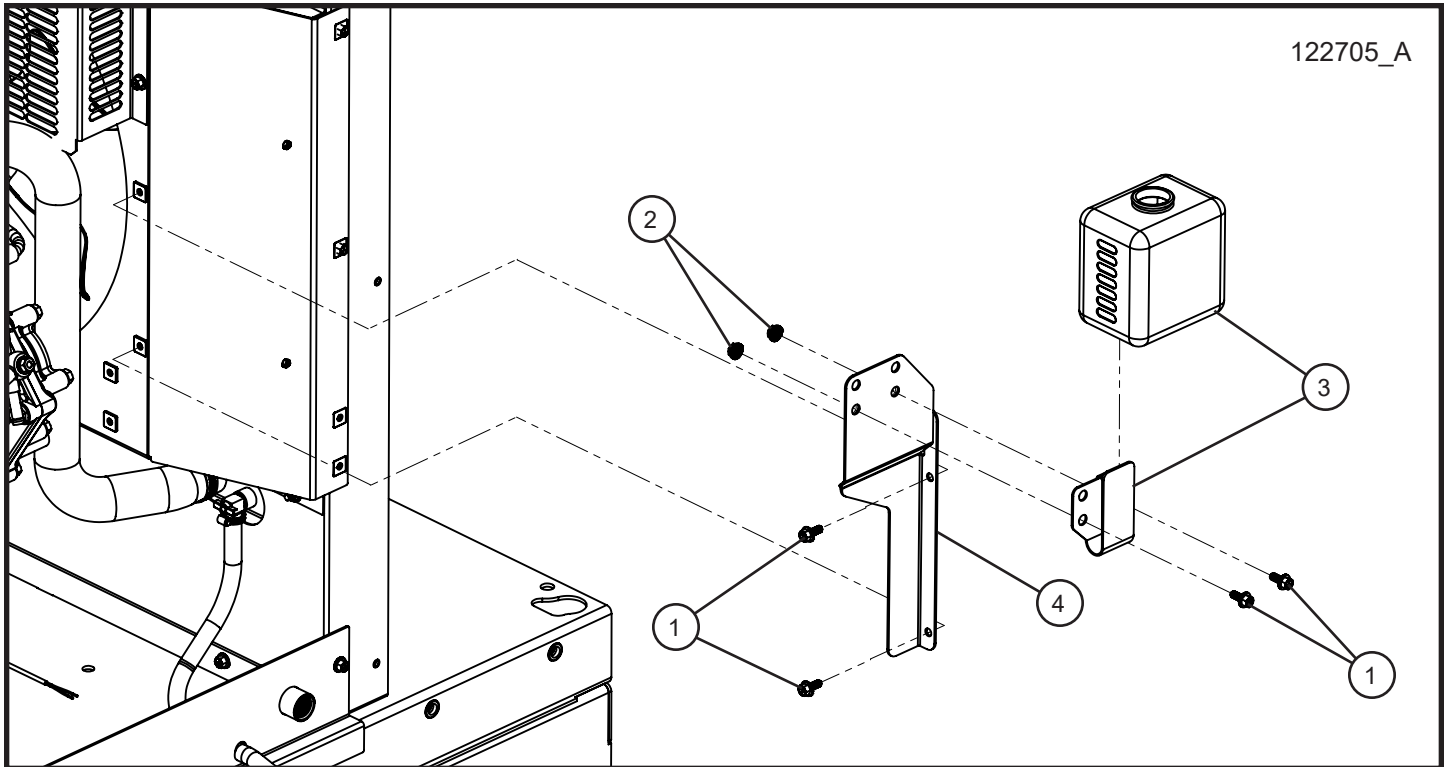

Maxi-Power™ 25

SN 48-000001 and UP

4.6 - Coolant Reservoir

Item	Part No.	Part Description	Qty.
1	056018	1/4-20 X 5/8 HEX SCREW SERRATED FLANGE	4
2	057000	1/4-20 HEX SERRATED FLANGE NUT	2
3	650027	RESERVOIR COOLANT WITH BRACKET ENGINE	1
4	120958P	MP25 OVERFLOW BOTTLE MOUNT	1
NS	102268	HOSE 1/4" OVERFLOW COOLANT X 30.5" L	1
NS	102268	HOSE 1/4" OVERFLOW COOLANT X 32.5" L	1
NS	433400	#4 HOSE CLAMP	3

NS - Not Shown

* * * - Contact Allmand for more information.

4.7 - Marathon Generator

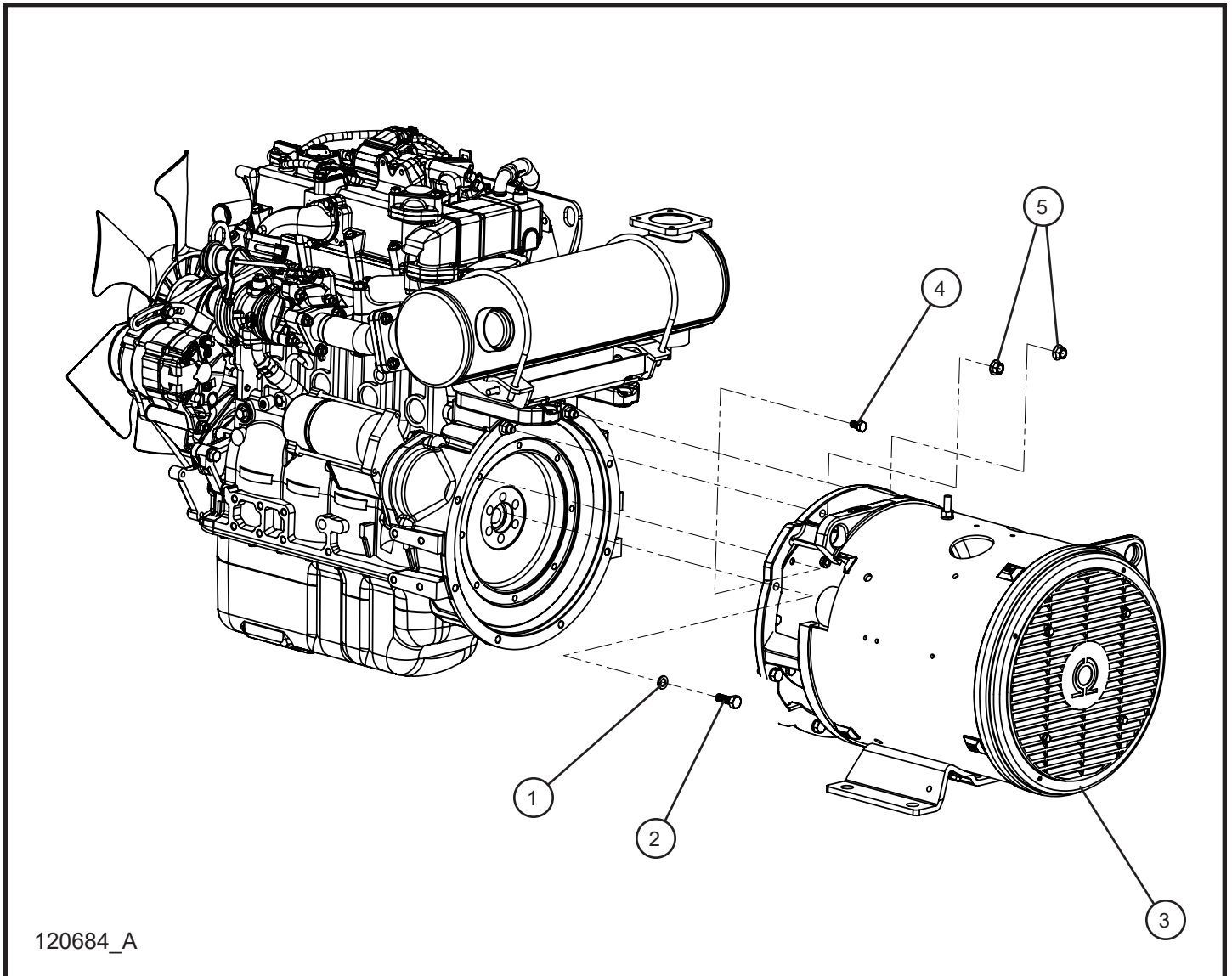

Maxi-Power™ 25

SN 48-000001 and UP

4.7 - Marathon Generator

Item	Allmand No.	Part Description	Qty.
1	042151	M10 SPLIT LOCK WASHER	6
2	042040	M10 x 1.5 x 30mm HEX HEAD CS	6
3	121791	MARATHON GENERATOR 282PSL1750	1
4	042027	M8 X 16mm X 1.25mm HEX HEAD CS	8
5	***		2
NS	123175	MARATHON GENERATOR 282PSL1750 AVR BOARD ASSEMBLY	1

NS - Not Shown

*** - Contact Allmand for more information.

4.8 - Engine and Generator Ground Wiring

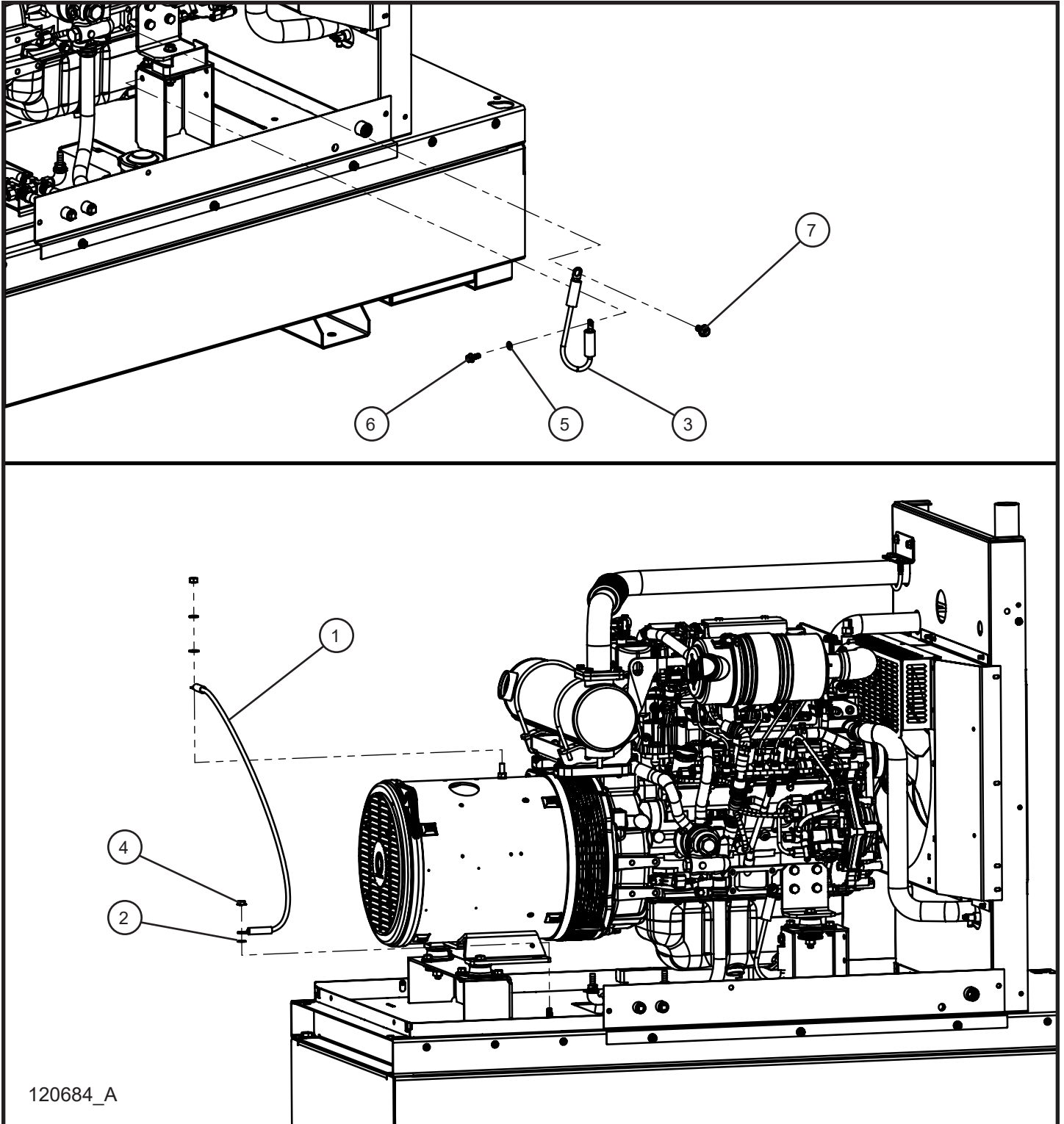

120684_A

Maxi-Power™ 25

SN 48-000001 and UP

4.8 - Engine and Generator Ground Wiring

Item	Allmand No.	Part Description	Qty.
1	121641	ALTERNATOR GROUND CABLE MP25 & MP45	1
2	043070	3/8 INTL TOOTH LOCK WASHER PL	1
3	121554	BATTERY CABLE MP25 & MP45	1
4	044036	3/8-16 KEPS HEX NUT	1
5	043060	5/16 INTL TOOTH LOCK WASHER	1
6	056038	5/16-18 X 3/4 HEX FLANGE SCREW GRAD5 ZINC	1
7	056004	M10 X 1.5 X 20 SERRATED FLANGE HEX BOLT	1

NS - Not Shown

* * * - Contact Allmand for more information.

Maxi-Power™ 25

SN 48-000001 and UP

5.1 - Fuel Tank

Item	Allmand No.	Part Description	Qty.
1	121333	SEALING WASHER DRAIN PLUG	1
2	056001	1/4-20 X 1/2 HEX SERRATED FLANGE SCREW	2
3	433400	#4 HOSE CLAMP	4
4	044029	3/8-16 SERRATED FLANGE NUT	4
5	057006	5/16-18 SERRATED FLANGE NUT	2
6	046069	5/16-18 X 2 HEX HEAD CS	2
7	118734	FUEL CAP Ø2.59	1
8	030010	RUBBER SEAL X 24.00	2
9	121269	DRAIN PLUG CONTAINMENT TANK	1
10	026108	PLUG PIPE 1 NPT SQUARE HEAD	1
11	026106	PLUG 1/2 NPT SQUARE HEAD	1
12	104133	1/2 BALL VALVE	1
13	610215	1/2 NPT NIPPLE	1
14	118752	FITTING SWIVEL BARBED 3/8 HOSE TO 3/8 NPSM	1
15	118701	FUEL TANK MP25	1
16	101266	HOSE FUEL LINE RUBBER .375 X 11.75	1
17	101266	HOSE FUEL LINE RUBBER .375 X 12.25	1
18	101266	HOSE FUEL LINE RUBBER .375 X 9.00	1
19	101270	3/8 HOSE BARB TO 3/8 MNPT	1
20	121264P	BRACKET CONTAINMENT TANK LEVEL SENSOR	1
21	121265	SENSOR CONTAINMENT TANK	1
22	121266	CLIP CONTAINMENT TANK SENSOR	1
23	121267	FUEL LEVEL SENDER VERTICAL SHAFT	1
24	121256P	WELDMENT FUEL TANK STRAP 1	2
25	121260	FUEL TANK STRAP CUSHION	4
26	121263P	WELDMENT FUEL TANK STRAP MP25	2
27	030010	RUBBER SEAL X 26.25	2
28	030010	RUBBER SEAL X 63.00	2
NS	118735	STRAINER FUEL TANK	1

NS - Not Shown

* * * - Contact Allmand for more information.

5.2 - Remote Fuel Group

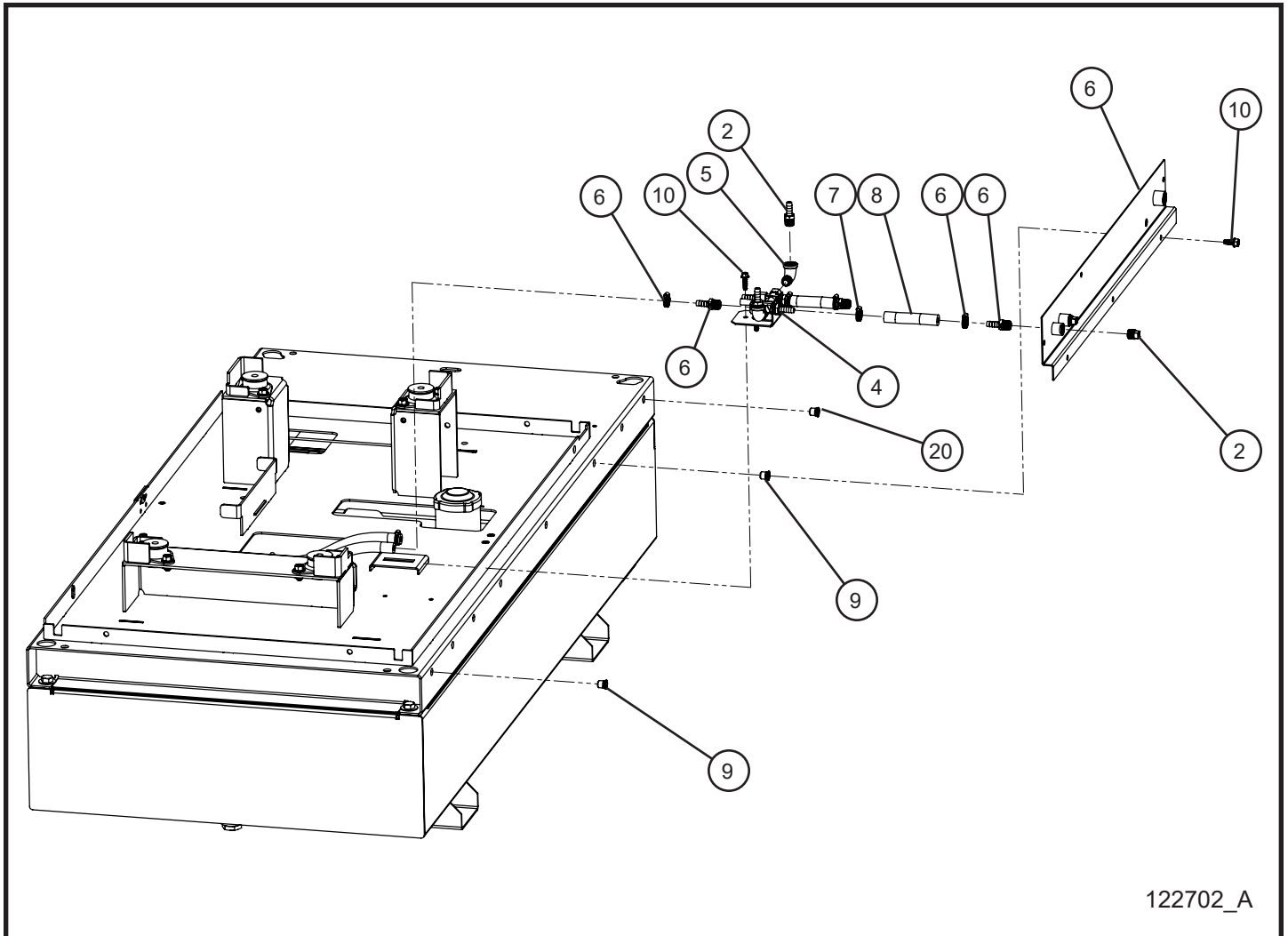

122702_A

Maxi-Power™ 25

SN 48-000001 and UP

5.2 - Remote Fuel Group

Item	Allmand No.	Part Description	Qty.
1	056017	1/4-20 X 1.00 SERRATED FLANGE HEX BOLT	2
2	052180	PIPE PLUG 3/8 NPTM BLACK	2
3	122725	FUEL DIVERTER SYSTEM	1
4	052175	90° ELBOW 3/8 NPT TO 3/8 NPT MALE TO FEMALE	2
5	101270	3/8 HOSE BARB TO 3/8 MNPT	6
6	118848P	WELDMENT FLUID CONNECTION PANEL MP25	1
7	101266	HOSE FUEL LINE RUBBER .375 X 4.00	2
8	433400	#4 HOSE CLAMP	6
9	118800	RIVNUT 5/16-18 .027-.150 GRIP RANGE	12
10	056038	5/16-18 X 3/4 HEX FLANGE SCREW	3

NS - Not Shown

* * * - Contact Allmand for more information.

5.3 - Battery Cables Group

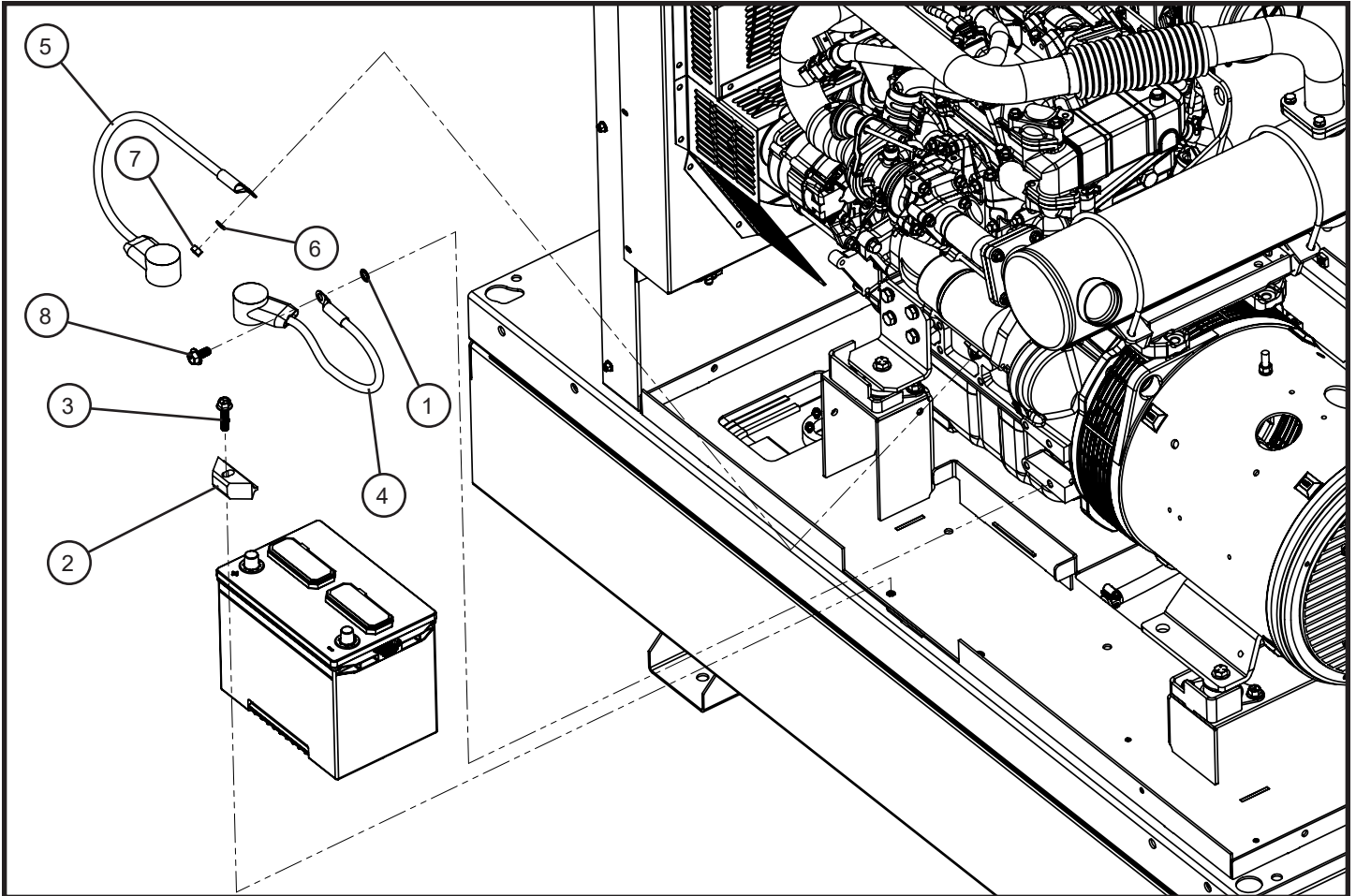

120975_A

Maxi-Power™ 25

SN 48-000001 and UP

5.3 - Battery Cables Group

Item	Allmand No.	Part Description	Qty.
1	043070	3/8 INTL TOOTH LOCK WASHER	1
2	107115	BATTERY HOLD DOWN	1
3	056015	3/8-16 X 1 1/2 HEX FLANGE SCREW	1
4	110373	BATTERY CABLE BLACK 2GA 16.00 NEG .375 EYE	1
5	121556	BATTERY CABLE RED 2GA X 16.00 POS .375 EYE	1
6	043020	1/4 SPLITLOCK WASHER	1
7	042080	M6 x 1.0mm HEX NUT	1
8	056004	M10 x 1.5 x 20 SERRATED FLANGE HEX BOLT	1

NS - Not Shown

* * * - Contact Allmand for more information.

Maxi-Power™ 25

SN 48-000001 and UP

5.4 - Battery Disconnect Group

Item	Allmand No.	Part Description	Qty.
1	043070	3/8 INTL TOOTH LOCK WASHER	1
2	056004	M10 x 1.5 x 20 SERRATED FLANGE HEX BOLT	1
3	046010	1/4-20 X 3/4 HEX HEAD CS	2
4	107115	BATTERY HOLD DOWN	1
5	056015	3/8-16 X 1 1/2 HEX FLANGE SCREW	1
6	121556	BATTERY CABLE RED 2GA X 16.00 POS .375 EYE	1
7	124156P	BATTERY DISCONNECT BRACKET MP25	1
8	102534	SWITCH BATTERY DISCONNECT 4 TERMINAL	1
9	103483	LOCK OUT BATTERY DISCONNECT	1
10	104777	DECAL BATTERY DISCONNECT	1
11	041024	#10-24 X 1/2 PH-ROUND HEAD	2
12	027015	BATTERY CABLE BLACK 2GA 27.00 NEG	1
13	105111	BATTERY CABLE BLACK X 42.0 BATTERY DISCONNECT	1
14	047005	1/4 FLAT WASHER	1

NS - Not Shown

* * * - Contact Allmand for more information.

5.5 - Block Heater, Battery Heater and Charger

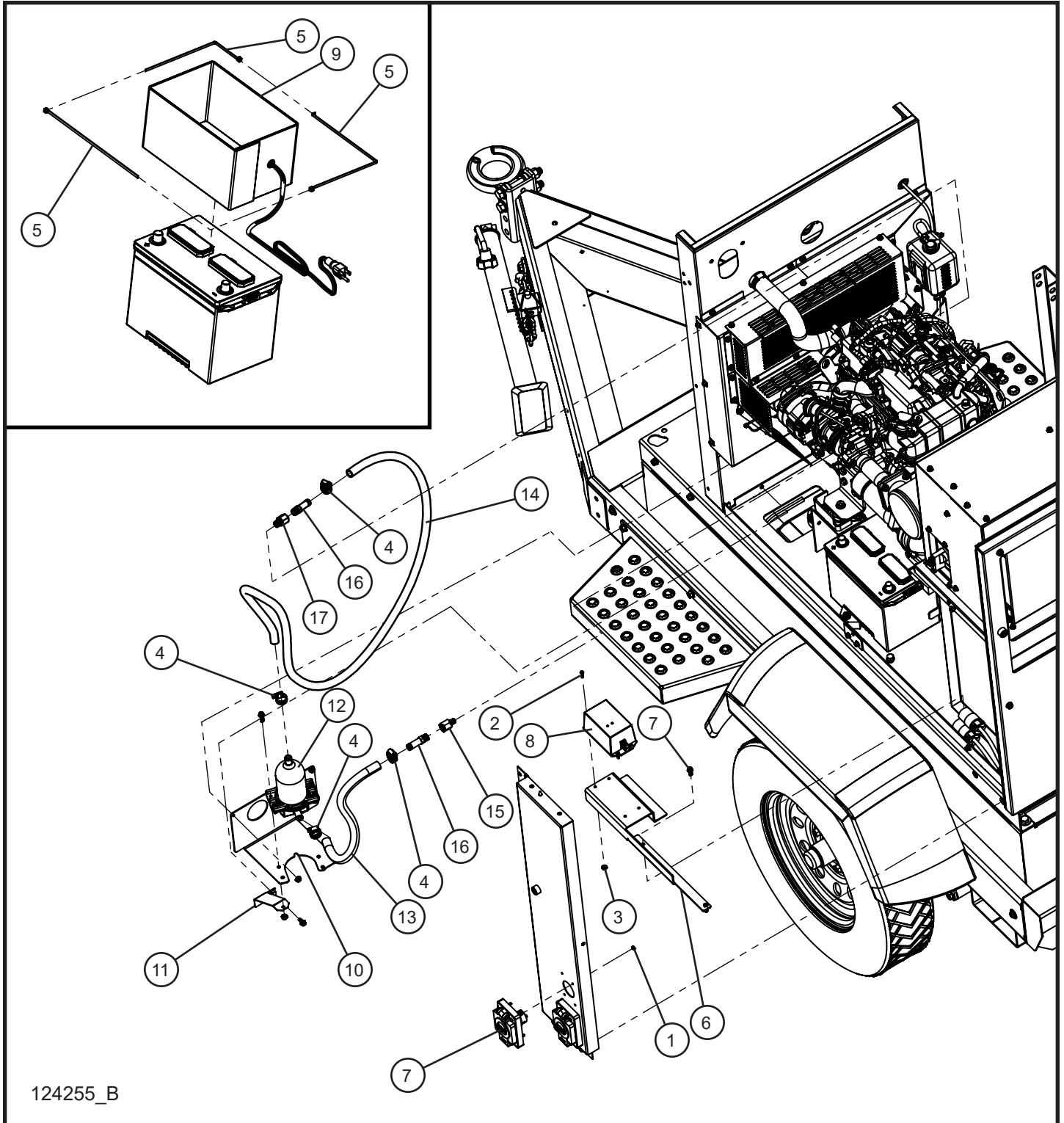

124255_B

Maxi-Power™ 25

SN 48-000001 and UP

5.5 - Block Heater, Battery Heater and Charger

Item	Part No.	Part Description	Qty.
1	044004	#6-32 KEPS HEX NUT PL	8
2	041027	#10-24 X .750 PH-ROUND HEAD MS	4
3	044016	#10-24 KEPS HEX NUT PL	4
4	045033	#10 HOSE CLAMP	4
5	068046	15" BLACK CABLE TIE	3
6	118833P	BRACKET MP25 BATTERY CHARGER	1
7	116990	15A 2P 3WR SINGLE LEVITON INLET	2
8	124262	BATTERY CHARGER MAXI-POWER 25	1
9	024010	80 WATT BATTERY BLANKET	1
10	117802P	MOUNT BLOCK HEATER MAXI-POWER 25	1
11	117801P	BRACE COOLANT HEATER MAXI-POWER 25	1
12	112426	BLOCK HEATER TANK STYLE 1000W 120V	1
13	081025	5/8 HEATER HOSE X 22.00	1
14	081025	5//8 HEATER HOSE X 72.00	1
15	112581	FITTING ADAPTOR 1/4" BSPT TO 3/8" NPT	1
16	112562	FITTING HOSE BARB 3/8" NPT - 5/8" BARB	2
17	104798	FITTING ADAPTOR 3/8" BSPT TO 3/8" NPT	1
18	112592	90° FITTING 3/8" NPT - 5/8" BARB	1
NS	124267	ARCTIC PACKAGE CORD EXTENSION	2
NS	124266	SCHEMATIC ARCTIC PACKAGE MAXI-POWER	1

NS - Not Shown

* * * - Contact Allmand for more information.

6.1 - Branding Decals

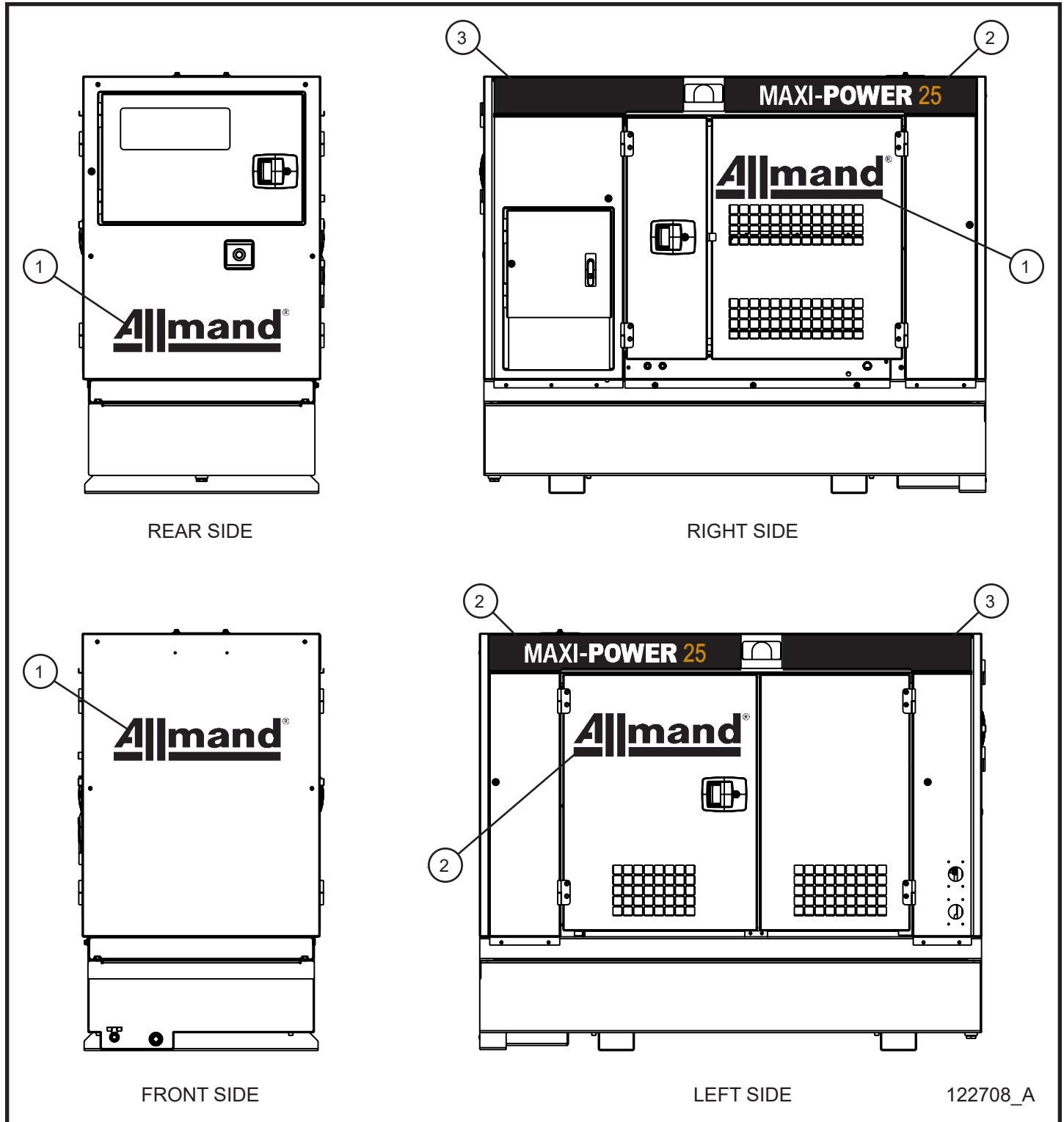

122708_A

Maxi-Power™ 25

SN 48-000001 and UP

6.1 - Branding Decals

Item	Allmand No.	Part Description	Qty.
1	118119	DECAL ALLMAND 23.3	4
	118425	DECAL BRANDING ALLMAND-R GOLD-WHITE 23.3 INCH	4
2	122457	DECAL BRANDING MAXI-POWER 25 BLACK RF/LF BANNER	2
3	122458	DECAL BRANDING BLACK RR/LR BANNER	2

NS - Not Shown

* * * - Contact Allmand for more information.

6.2 - Front and Rear Side Safety Decals

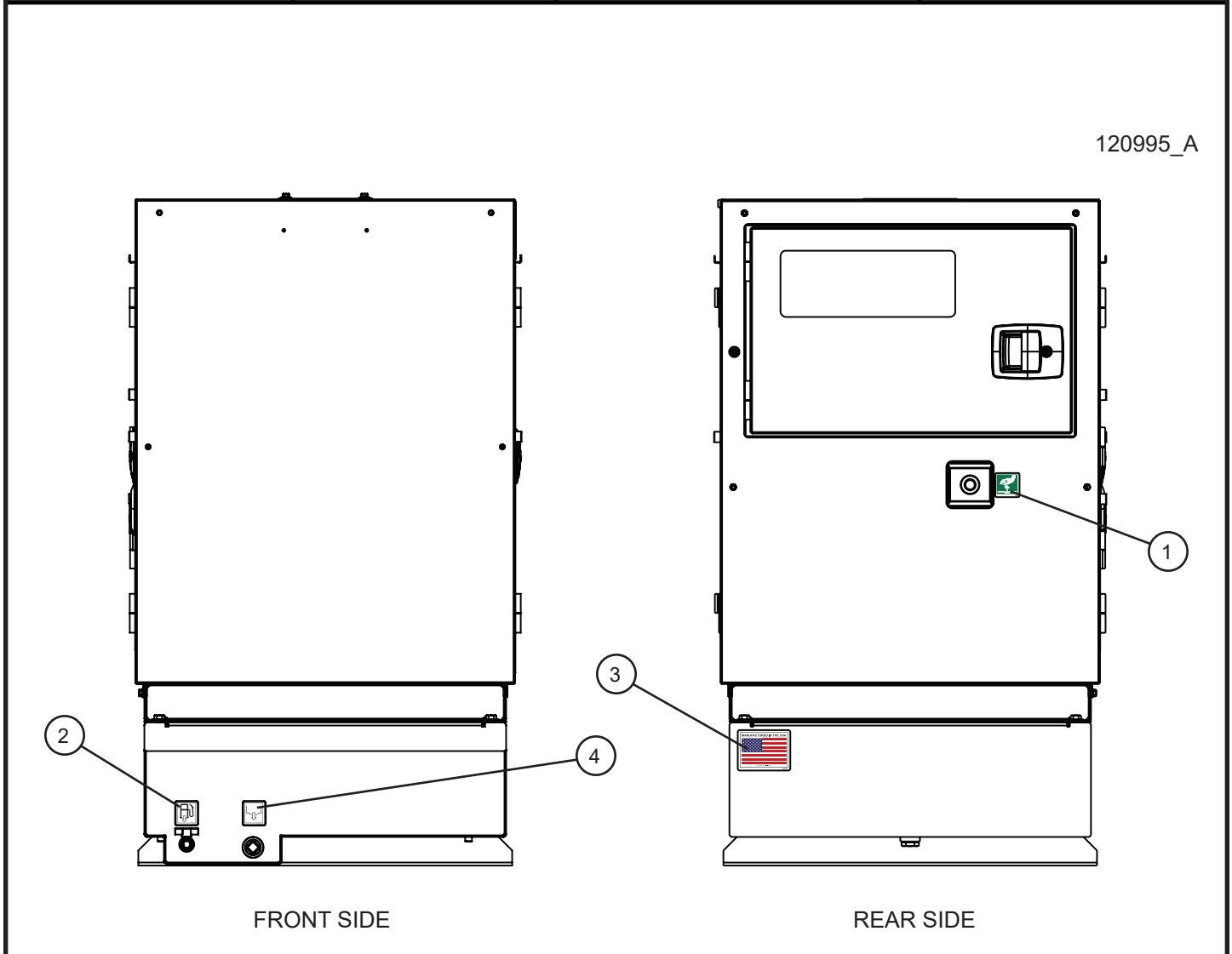
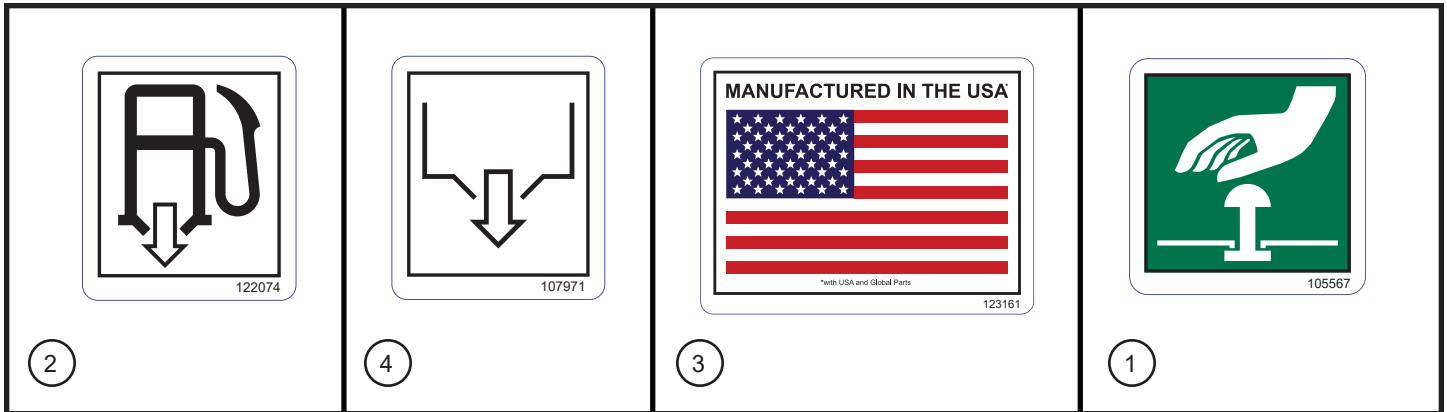

Maxi-Power™ 25

SN 48-000001 and UP

6.2 - Front and Rear Side Safety Decals

Item	Allmand No.	Part Description	Qty.
1	105567	DECAL EMERGENCY STOP	1
2	122074	DECAL FUEL DRAIN	1
3	123161	DECAL MANUFACTURED IN USA	1
4	107971	DECAL FLUID CONTAINMENT DRAIN	1

NS - Not Shown

* * * - Contact Allmand for more information.

6.3 - Right Side Safety Decals

NOTICE
Machine to be grounded in accordance with requirements as outlined by local inspection authorities.

AVIS
Neutre mis à la masse à la carcasse du moteur.
L'appareil doit être mis à la terre conformément aux exigences des services d'inspection locaux.

122470

REMOTE FUEL RETURN
RENOI DE CARBURANT À DISTANCE

REMOTE FUEL SUPPLY
ALIMENTATION DE CARBURANT À DISTANCE

122090

WARNING

AVERTISSEMENT

118162

NOTICE
Route power cables under panel door to power distribution terminals and single phase outlets.

AVIS
Acheminer les câbles d'alimentation sous la porte à panneau jusqu'aux bornes de distribution de courant et aux prises monophasées.

122081

120995_A

kW/kVA	20.0/25.0	20.0/25.0	14.4/14.4
A	30 MAX	69 MAX	60 MAX
V _L /V _{LL}	277/480	120/208	120/240
Hz/RPM	60/1800	60/1800	60/1800
Φ	3	3	1
INS. CLASS	H	H	H
MAX AMB	115°F/46°C	115°F/46°C	115°F/46°C
PF	0.8	0.8	1.0

122053

DANGER

Entering electrical compartment while equipment is in operation will result in death or serious injury.
Shut down equipment before entering electrical compartment.

DANGER

Le fait d'entrer dans le compartiment électrique tandis que l'équipement est utilisé causera la mort ou des blessures graves.
Éteindre l'équipement avant d'entrer dans le compartiment électrique.

118104

104752

107973

RIGHT SIDE

Maxi-Power™ 25

SN 48-000001 and UP

6.3 - Right Side Safety Decals

Item	Allmand No.	Part Description	Qty.
1	104752	DRAIN DECAL ENGINE COOLANT	1
2	122090	DECAL REMOTE FUEL CONNECTION	1
3	118162	DECAL WARNING HOT SURFACE ENGLISH & FRENCH	1
4	122081	DECAL TERMINAL CONNECTIONS NOTICE MAXI-POWER	1
5	118104	DECAL DANGER VOLTAGE ELECTRICAL COMPARTMENT	1
6	122083	DECAL ELECTRICAL INFORMATION MAXI-POWER 25	1
7	122470	DECAL NEUTRAL/GROUNDED ENGLISH/FRENCH	1
8	107973	DECAL OIL DRAIN	1

NS - Not Shown

* * * - Contact Allmand for more information.

6.4 - Right Side Interior Safety Decals

2

122085

120995_A

FUEL NECK DETAIL

4

107045

1

RIGHT SIDE INTERIOR

3

118652

2

122075

1

122075

Maxi-Power™ 25

SN 48-000001 and UP







6.4 - Right Side Interior Safety Decals

Item	Allmand No.	Part Description	Qty.
1	122075	DECAL HOT SURFACE / AUTOSTART WARNING MAXI-POWER	1
2	122085	DECAL REMOTE FUEL WARNING AND INSTRUCTIONS	1
3	118652	DECAL FAN/BELT ENTANGLEMENT WARNING BI-LINGUAL	1
4	107045	LOW SULFUR FUEL DECAL	1

NS - Not Shown

* * * - Contact Allmand for more information.

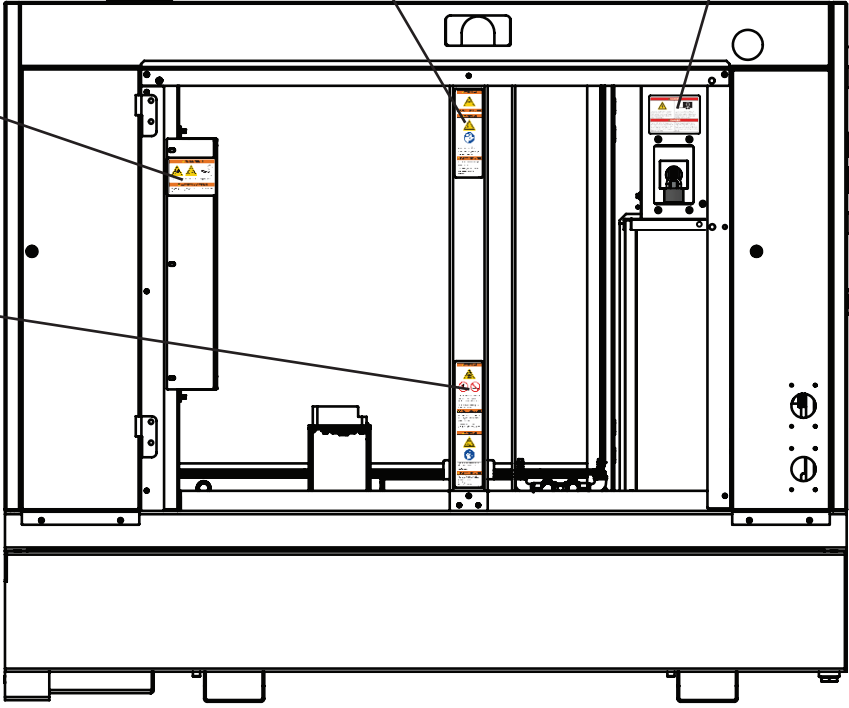
6.5 - Left Side Interior Safety Decals

<div data-bbox="149 464 643 831"> <p>⚠ DANGER</p>  <p>Turning the voltage switch to another position while the unit is in operation could cause an electric shock hazard from the generator which will result in death or serious injury.</p> <p>⚠ DANGER</p> <p>Tourner l'interrupteur de tension à une autre position pendant que l'appareil est en marche pourrait présenter un risque de choc électrique de la génératrice pouvant entraîner la mort ou de graves blessures corporelles.</p> <p>Turn off the unit before turning the voltage switch to another position. A lock must be installed on the switch to prevent the switch from being turned while the unit is in operation.</p> <p>Éteindre l'appareil avant de tourner l'interrupteur de tension à une autre position. Un cadenas doit être posé sur l'interrupteur pour empêcher qu'il puisse être tourné pendant que l'appareil est en marche.</p> <p>122086</p> </div> <p>4</p>	<div data-bbox="738 464 1209 831"> <p>⚠ WARNING</p>  <p>Contact with rotating parts could result in death or serious injury.</p> <p>Keep away from rotating parts.</p> <p>⚠ AVERTISSEMENT</p> <p>Le contact avec des pièces en mouvement pourrait résulter en de graves blessures voire la mort.</p> <p>Se tenir à l'écart des pièces en mouvement.</p> <p>118652</p> </div> <p>2</p>	<div data-bbox="1307 464 1469 1176"> <p>⚠ WARNING</p>  <p>Smoking materials, open flames, or other forms of ignition near the battery could cause explosion resulting in death or serious injury. Keep smoking materials, open flames, and other forms of ignition away from the battery.</p> <p>⚠ AVERTISSEMENT</p> <p>Les articles de fumeur, les flammes nues ou d'autres formes d'allumage près de la batterie pourraient causer une explosion, causant la mort ou des blessures graves.</p> <p>Tenir les articles de fumeur, les flammes nues ou les autres formes d'allumage à l'écart de la batterie.</p> <p>⚠ WARNING</p>  <p>Exposure to corrosive material could result in death or serious injury. Wear protective gloves when handling battery.</p> <p>⚠ AVERTISSEMENT</p> <p>Toute exposition à des produits corrosifs pourrait causer la mort ou des blessures graves.</p> <p>Porter des gants de protection en manipulant la batterie.</p> <p>122076</p> </div> <p>3</p>	
<div data-bbox="121 976 1079 1837">  </div> <p>LEFT SIDE INTERIOR</p> <p>120995_A</p>			<div data-bbox="1307 1333 1469 1837"> <p>⚠ WARNING</p>  <p>⚠ AVERTISSEMENT</p> <p>⚠ WARNING</p>  <p>Unexpected start of engine could result in death or serious injury. Read and follow electronic controller operator's manual before operating or servicing this equipment.</p> <p>⚠ AVERTISSEMENT</p> <p>Le démarrage inattendu du moteur pourrait provoquer la mort ou des blessures graves.</p> <p>Lire et suivre le manuel d'utilisation du contrôleur électronique avant d'utiliser ou de réparer cet équipement.</p> <p>122075</p> </div> <p>1</p>

Maxi-Power™ 25

SN 48-000001 and UP





6.5 - Left Side Interior Safety Decals

Item	Allmand No.	Part Description	Qty.
1	122075	DECAL HOT SURFACE / AUTOSTART WARNING MAXI-POWER	1
2	118652	DECAL FAN/BELT ENTANGLEMENT WARNING BI-LINGUAL	1
3	122076	DECAL BATTERY WARNINGS MAXI-POWER	1
4	122086	DECAL VOLTAGE CHANGE DEVICE WARNING	1

NS - Not Shown

* * * - Contact Allmand for more information.

6.6 - Top Side Safety Decals

 WARNING Opening cap on hot radiator could result in death or serious injury. Allow radiator to cool down before opening cap.	 	 AVERTISSEMENT L'ouverture du bouchon sur un radiateur chaud pourrait causer la mort ou des blessures graves. Laisser le radiateur refroidir avant de dévisser le bouchon.
---	--	--

118651

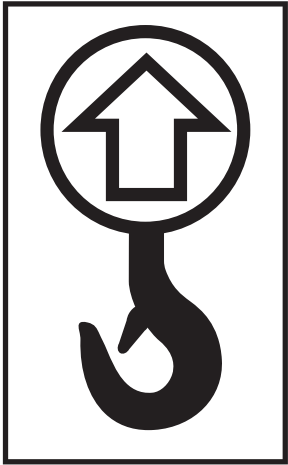

122480

1

120995_A

2

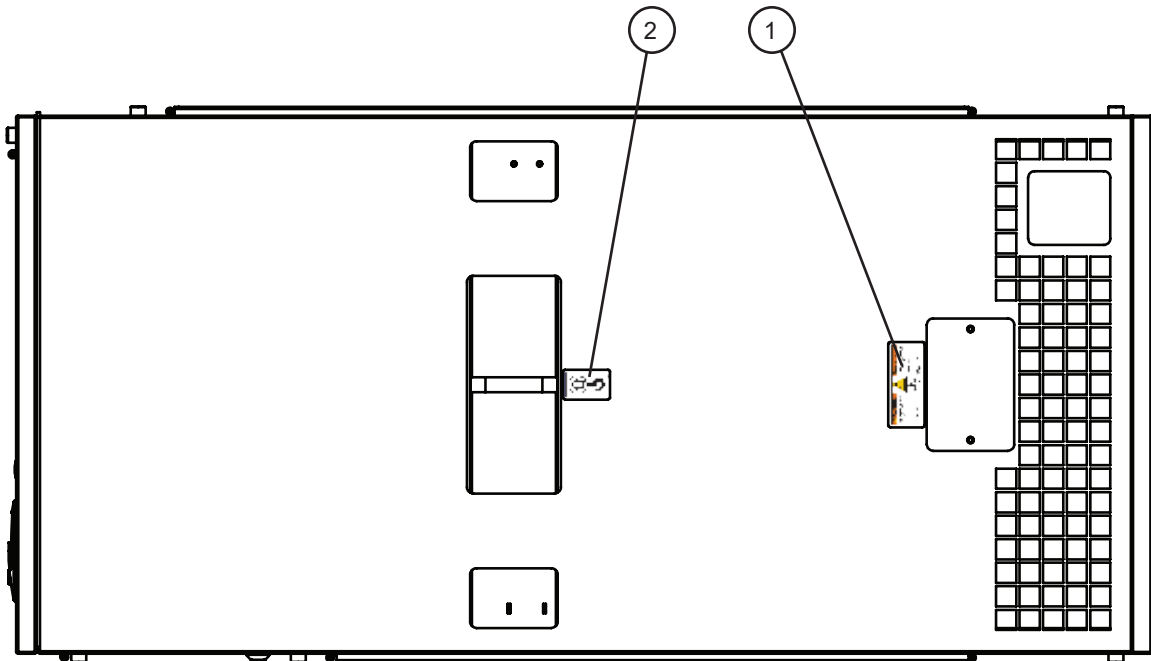

TOP SIDE

Maxi-Power™ 25

SN 48-000001 and UP

6.6 - Top Side Safety Decals

Item	Allmand No.	Part Description	Qty.
1	118651	DECAL RADIATOR WARNING BI-LINGUAL	1
2	122480	DECAL LIFT HOOK	1

NS - Not Shown

* * * - Contact Allmand for more information.

6.7 - Control Box Safety Decals









<p>⚠ WARNING</p> <p>Failure to follow warnings, instructions, and operator's manual could result in death or serious injury.</p> <p>Read and follow operator's manual before operating or servicing this equipment.</p>	<p>⚠ AVERTISSEMENT</p> <p>L'omission de respecter les avertissements, les instructions et le manuel de l'utilisateur pourrait entraîner des blessures graves ou la mort.</p> <p>Lire et suivre le manuel d'utilisation avant de faire fonctionner ou de faire l'entretien de cet équipement.</p>	<p>⚠ WARNING</p> <p>Breathing diesel engine exhaust exposes you to chemicals known to the State of California to cause cancer and birth defects or other reproductive harm.</p>	<p>⚠ AVERTISSEMENT</p> <p>L'inspiration de gaz d'échappement du moteur vous expose à des produits chimiques connus selon l'État de Californie pour causer le cancer, des anomalies congénitales ou d'autres effets nuisibles à la reproduction.</p>
<p>⚠ WARNING</p> <p>Engine exhaust contains carbon monoxide, a poisonous gas that could cause death or serious injury.</p> <p>Run equipment far from windows, doors and vents. Do not run equipment indoors or in partially enclosed spaces.</p>	<p>⚠ AVERTISSEMENT</p> <p>Le moteur contient du monoxyde de carbone, un gaz toxique pouvant provoquer la mort ou de graves blessures.</p> <p>Faites tourner à l'extérieur, loin des fenêtres, des portes et des vents. Ne faites pas fonctionner à l'intérieur ni dans un espace partiellement fermé.</p>	<p>• Always start and operate the engine in a well-ventilated area.</p> <p>• If in an enclosed area, vent the exhaust to the outside.</p> <p>• Do not modify or tamper with the exhaust system.</p> <p>• Do not idle the engine except as necessary.</p> <p>• Toujours démarrer et faire fonctionner le moteur dans un endroit bien ventilé.</p> <p>• Si le moteur est utilisé dans un espace fermé, ventiler les gaz d'échappement à l'extérieur.</p> <p>• Ne pas modifier ni altérer le système d'échappement.</p> <p>• Ne pas mettre le moteur au ralenti sauf en cas de nécessité.</p>	

www.P65Warnings.ca.gov/diesel. 122985

MAXI-POWER 25



123249

<p>OPERATION CHECKLIST</p> <ol style="list-style-type: none"> 1. Check engine oil and coolant levels. Refill as needed. 2. Check fuel tank (and, if equipped, DEF) tank levels. Refill as needed. 3. Drain water from fuel-water separator. 4. Set the voltage selector switch to the correct voltage and phase position that is required for operation. 	<p>LISTE DE VÉRIFICATION DE FONCTIONNEMENT</p> <ol style="list-style-type: none"> 1. Vérifier les niveaux d'huile moteur et liquide de refroidissement. Remplir si nécessaire. 2. Vérifier les niveaux du réservoir de carburant et du réservoir DEF, si équipé. Remplir si nécessaire. 3. Vidanger l'eau du séparateur carburant-eau. 4. Régler l'interrupteur du sélecteur de tension à la bonne tension et position de phase requises pour le fonctionnement. 		
<p>MANUAL MODE OPERATION</p> <p>MANUAL MODE START</p> <ol style="list-style-type: none"> 1. Set all the circuit breakers (main and outlet) to the OFF/0 position. 2. Set the electronic controller power switch to the ON/1 position. 3. Press the manual mode button . 4. Press the start button  to start the engine run cycle. The engine will cycle through the stages of preheat, engine start, engine warming, and engine run. Allow the engine to run for approximately 5 minutes. 5. Adjust the voltage as needed by using the voltage adjustment control knob. 6. Set all the circuit breakers (main and outlet) to the ON/1 position. <p>MANUAL MODE STOP</p> <ol style="list-style-type: none"> 1. Set all the circuit breakers (main and outlet) to the OFF/0 position. 2. Press the stop button  to shutdown the engine. 3. Set the electronic controller power switch to the OFF/0 position. 	<p>FONCTIONNEMENT EN MODE MANUEL</p> <p>DEMARRAGE EN MODE MANUEL</p> <ol style="list-style-type: none"> 1. Régler tous les disjoncteurs (principal et prises) à la position ARRÊT/0. 2. Régler l'interrupteur d'alimentation de la commande électronique à la position MARCHE/1. 3. Appuyer sur le bouton du mode manuel . 4. Appuyer sur le bouton de démarrage  pour démarrer un cycle de moteur. Le moteur fera un cycle des étapes de préchauffage, démarrage du moteur, réchauffement du moteur et fonctionnement du moteur. Laisser le moteur tourner pendant environ 5 minutes. 5. Régler la tension au besoin en utilisant le bouton de contrôle pour le réglage de la tension. 6. Régler tous les disjoncteurs (principal et prises) à la position MARCHE/1. <p>ARRÊT DU MODE MANUEL</p> <ol style="list-style-type: none"> 1. Régler tous les disjoncteurs (principal et prises) à la position ARRÊT/0. 2. Appuyer sur le bouton d'arrêt  pour arrêter le moteur. 3. Régler l'interrupteur d'alimentation de la commande électronique à la position ARRÊT/0. 		
<p>AUTO MODE OPERATION</p> <p>* Refer to the operator's manual  for instruction.</p>		<p>FONCTIONNEMENT EN MODE AUTOMATIQUE</p> <p>* Reportez-vous au manuel d'utilisation  pour plus d'informations.</p>	

122985

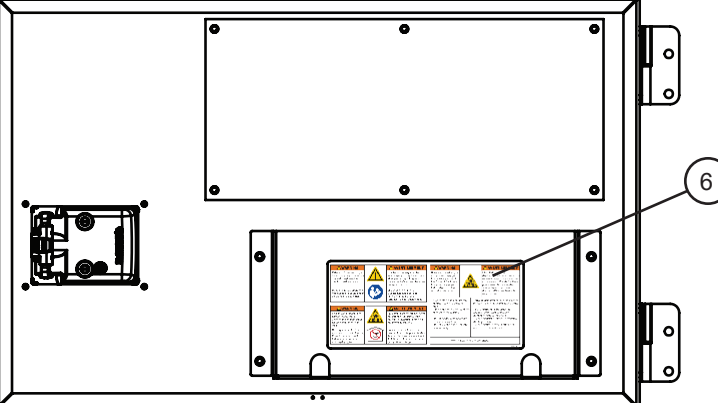

CONTROL PANEL DOOR

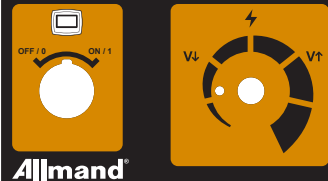

4

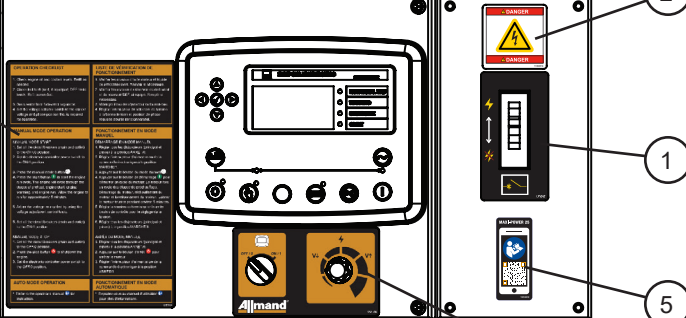

CONTROL PANEL

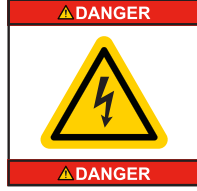

2

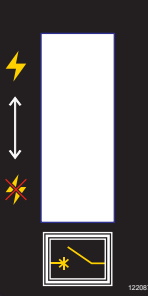

1

Maxi-Power™ 25

SN 48-000001 and UP

6.7 - Control Box Safety Decals

Item	Allmand No.	Part Description	Qty.
1	122087	DECAL BREAKER DECAL MAXI-POWER	1
2	118074	DECAL BILINGUAL DANGER HAZARDOUS VOLTAGE VERTICAL	1
3	122080	DECAL DSE OPERATOR INSTRUCTIONS MAXI-POWER	1
4	122078	DECAL CONTROL PANEL MAXI-POWER	1
5	123249	DECAL QR CODE MAXI-POWER 25	1
6	122985	DECAL MULTIPLE EXHAUST WARNING MAXI POWER	1
NS	123581	INSERT BANNER RIGHT SIDE DEEP SEA 7310 MAXI-POWER	1
NS	123580	INSERT BANNER TOP DEEP SEA 7310 MAXI-POWER	1

NS - Not Shown

* * * - Contact Allmand for more information.

6.8 - Trailer Decals (1 of 2)



TIRE INFORMATION

The weight of cargo should never exceed 55 kg or 120 lbs.

TIRE	SIZE	COLD TIRE PRESSURE	SEE OWNER'S MANUAL FOR ADDITIONAL INFORMATION
FRONT	ST 205/75R15C	345kPa, 50PSI	
REAR	NONE	NONE	
SPARE	NONE	NONE	

123578

<p>NOTICE</p> <p>Ensure packaged equipment is level prior to operation. Maximum angle of operation $\pm 1.4^\circ$ (determined by manufacturer).</p>		<p>AVIS</p> <p>S'assurer que l'appareil monobloc est de niveau avant de l'utiliser. Angle maximal de fonctionnement $\pm 1.4^\circ$ (déterminé par le fabricant)</p> <p style="text-align: right; font-size: x-small;">122471</p>
--	---	---

124581_A
124161_A

WARNING



Excessive towing speed could result in death or serious injury.

Do not exceed 65mph (105km/h) when towing trailer.

AVERTISSEMENT

Une vitesse de remorquage excessive pourrait entraîner la mort ou de graves blessures.

Ne pas dépasser 105 km/h (65 mi/h) lors du remorquage.

118108

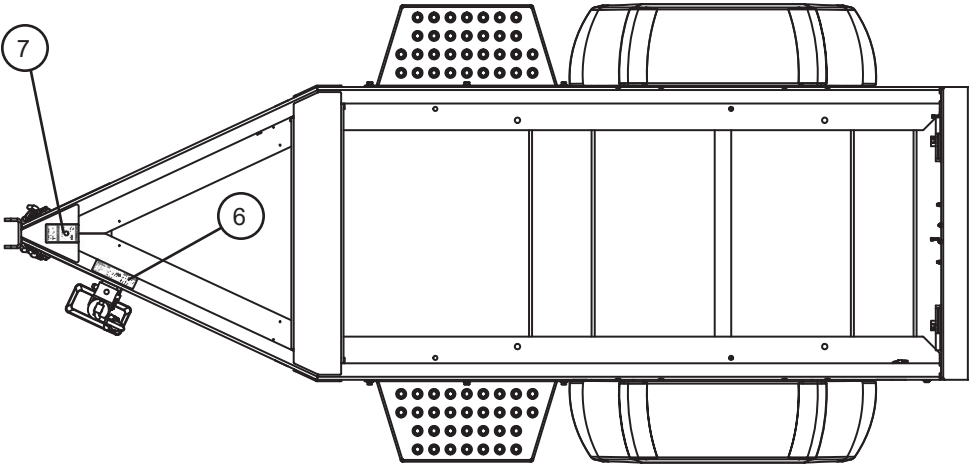

TOP SIDE VIEW

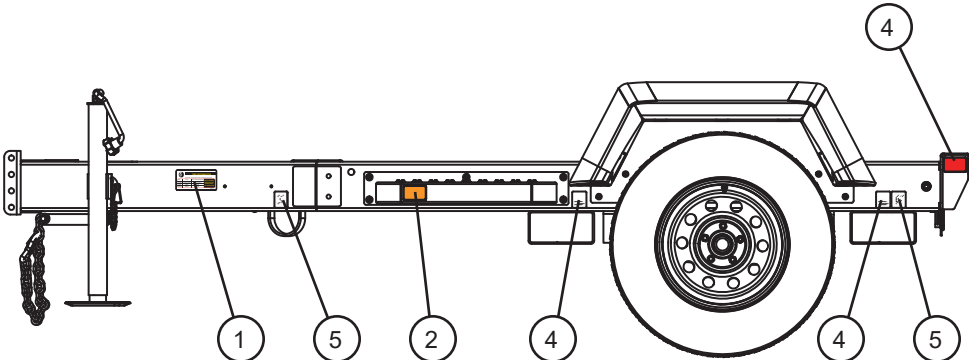

LEFT SIDE VIEW

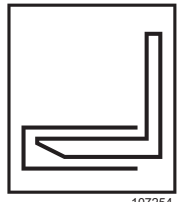

107254

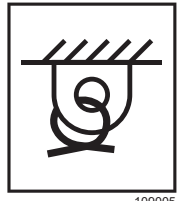

109005

Maxi-Power™ 25

SN 48-000001 and UP

6.8 - Trailer Decals (1 of 2)

Item	Allmand No.	Part Description	Qty.
1	123578	DECAL TIRE INFORMATION MAXI-POWER 25	1
2	114884	REFLECTOR DECAL AMBER 2.75 X 1.75	1
3	115286	REFLECTOR DECAL RED 2.75 X 1.75	1
4	107254	DECAL FORKLIFT WORDLESS	1
5	109005	DECAL TIE DOWN WORDLESS	1
6	122471	DECAL LEVEL TRAILER	1
7	118108	DECAL EXCESSIVE TOW SPEED WARNING	1

NS - Not Shown

* * * - Contact Allmand for more information.

6.8 - Trailer Decals (2 of 2)

124581_A

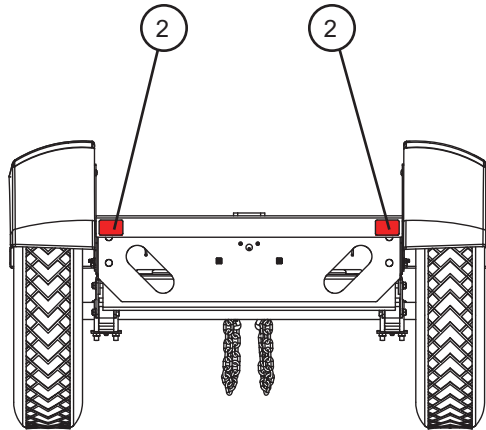

REAR SIDE VIEW

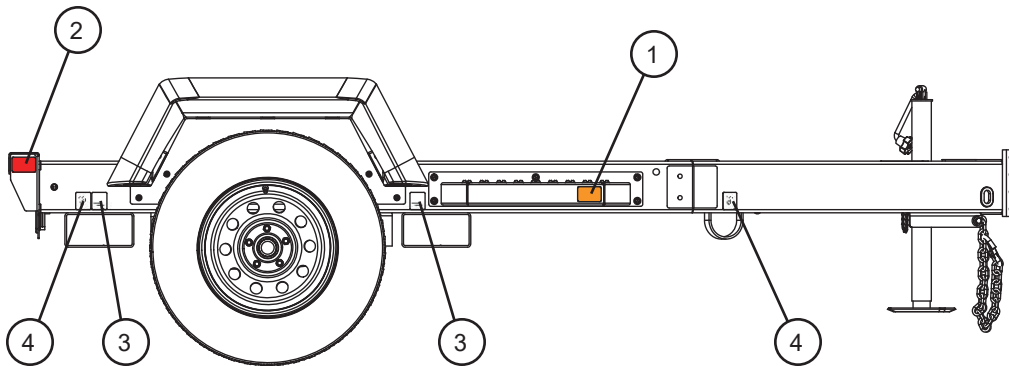

RIGHT SIDE VIEW

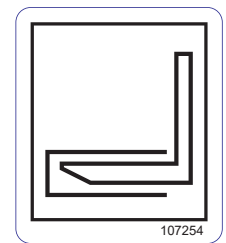

3

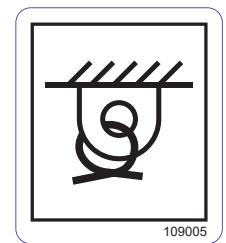

4

Maxi-Power™ 25

SN 48-000001 and UP

6.8 - Trailer Decals (2 of 2)

Item	Allmand No.	Part Description	Qty.
1	114884	REFLECTOR DECAL AMBER 2.75 X 1.75	1
2	115286	REFLECTOR DECAL RED 2.75 X 1.75	3
3	107254	DECAL FORKLIFT WORDLESS	1
4	109005	DECAL TIE DOWN WORDLESS	1

NS - Not Shown

* * * - Contact Allmand for more information.

Maxi-Power™ 25



1502 West 4th Avenue
Holdrege, NE 68949

phone: (308) 995-4495 • toll free: (800) 562-1373

fax: (308) 995-5887

www.allmand.com