

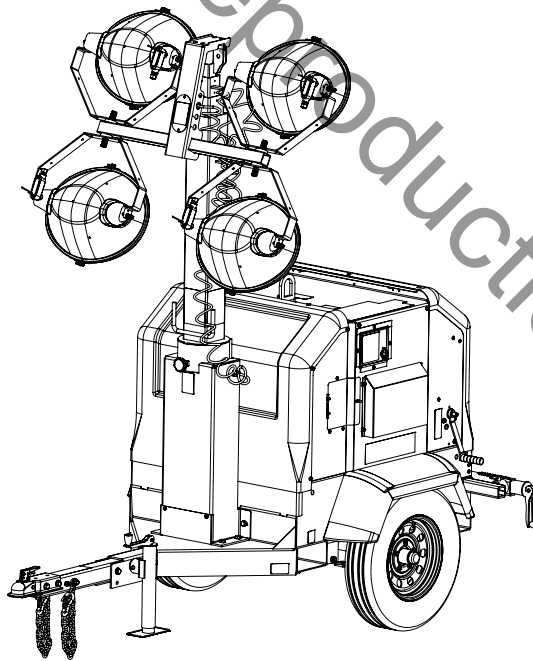

en Operator's Manual
NIGHT-LITE™ V-Series

Not for Reproduction



Record Important Information

Recording the equipment information will help when placing an order for replacement parts and/or decals.

Company Equipment No: _____

Unit Model No: _____

Unit Vin: _____

Engine Model No: _____ Serial No: _____

Generator Model No: _____ Serial No: _____

Accessories: _____

Manual Contents:

Introduction	2
Safety	2
Features and Controls	9
Preparing The Light Tower Trailer For Use	10
Operation	16
Maintenance	22
Specifications	26
Troubleshooting	28

Introduction

About This Manual

TAKE TIME TO READ THIS MANUAL THOROUGHLY

This instruction manual provides necessary instructions for the NIGHT-LITE™ V-Series light tower.

The information found in this manual is in effect at the time of printing. Allmand Bros Inc. may change contents without notice and without incurring obligation.

Any reference in this manual to left or right shall be determined by looking at the trailer from the rear.

If uncertain about any of the information in the manual, contact Allmand service department at 1-800-562-1373, or contact us through the Allmand website, www.allmand.com.

Save these original instructions for future reference.



Products Covered by This Manual

The following products are covered by this manual:

NIGHT-LITE™ V-Series

Safety

Safety Definitions

For your safety, the safety of others, and to protect the performance of equipment, follow the precautions listed throughout the manual before operation, during operation and during periodic maintenance procedures.



Indicates a potential personal injury hazard.

⚠ DANGER

Indicates a hazardous situation which, if not avoided, **will** result in death or serious injury.

⚠ WARNING

Indicates a hazardous situation which, if not avoided, **could** result in death or serious injury.

⚠ CAUTION

Indicates a hazardous situation which, if not avoided, **could** result in minor or moderate injury.

NOTICE

Indicates a situation which can cause damage to the equipment, personal property and/or the environment, or cause the equipment to operate improperly.

Safety Precautions

The following section contains general safety precautions and guidelines that must be followed to reduce risk to personal safety. Special safety precautions are listed in specific procedures. Read and understand all of the safety precautions before operating or performing repairs or maintenance.



DANGER

Electrocution Hazard

- Always check overhead wires and obstructions before raising or lowering the light tower.
- Always follow the rules or instructions for your work site and state, province and national electric code for maintaining a safe distance from overhead wires.
- High voltage is present when engine is running. Never attempt to service electrical components while engine is running.
- Do not operate the light tower if the insulation on the electrical cord or other electrical wiring is cut or worn or if bare wires are exposed. Repair or replace damaged wiring before starting the engine.



WARNING

Unsafe Operation Hazard

- Never permit anyone to install or operate the equipment without proper training.
- Read and understand this Operator's Manual and the Engine Operator's Manual before operating or servicing the light tower to ensure that safe operating practices and maintenance procedures are followed.
- Safety signs and decals are additional reminders for safe operating and maintenance techniques.



WARNING

Fall Hazard

- Never carry riders on the equipment.



WARNING

Modification Hazard

- Never modify the equipment without written consent of the manufacturer. Any modification can effect the safe operation of the equipment.



WARNING

Exposure Hazard

- Always wear personal protective equipment, including appropriate clothing, gloves, work shoes, and eye and hearing protection, as required by the task at hand.



WARNING

Rollover Hazard

- Do not raise, lower or use light tower unless all outriggers and jacks are positioned on firm ground.
- Never move or reposition the light tower while the light tower is extended in the vertical position.



WARNING

Batteries give off explosive gases during recharging. Sparks can cause explosions, resulting in death or serious injury.

Batteries contain acid, which is extremely caustic. Contact with battery contents will cause severe chemical burns.

Batteries present a risk of electric shock and high short circuit current.

- Always disconnect the negative (-) battery cable before servicing equipment.
- DO NOT dispose of battery in a fire. Recycle battery.
- DO NOT allow any open flame, spark, heat, or lit cigarette during and for several minutes after charging a battery.
- DO NOT open or mutilate battery.
- DO NOT charge a frozen battery. Always slowly warm the battery to room temperature before charging.
- Wear protective gloves, rubber apron, rubber boots and rubber gloves.
- Remove watches, rings, or other metal objects.
- Use tools having insulated handles.



WARNING

Fire And Explosion Hazard

- Diesel fuel is flammable and explosive under certain conditions.
- Never use a shop rag to catch fuel.
- Wipe up all spills immediately.
- Never refuel with the engine running.
- Store any containers containing fuel in a well ventilated area, away from any combustibles or sources of ignition.



WARNING

Exhaust Hazard

- All internal combustion engines create carbon monoxide gas during operation and special precautions are required to avoid carbon monoxide poisoning.
- Never block windows, vents or other means of ventilation if the equipment is operating in an enclosed area.
- Always ensure that all connections are tightened to specifications after repair is made to the exhaust system.



WARNING

Alcohol And Drug Hazard

- Never operate the light tower while under the influence of alcohol or drugs, or when ill.



WARNING

Entanglement / Sever Hazard

- Always stop the engine before beginning service.
- If the engine must be serviced while it is operating, remove all jewelry, tie back long hair and keep hands, other body parts and clothing away from moving/rotating parts.
- Verify that all guards and covers are attached properly to the equipment before starting the engine. Do not start the engine if any guards or covers are not properly installed on the equipment.
- Attach a "Do Not Operate" tag near the key switch while performing maintenance on the equipment.



WARNING

Flying Object Hazard

- Always wear eye protection when cleaning the equipment with compressed air or high pressure water. Dust, flying debris, compressed air, pressurized water or steam may injure your eyes.



WARNING

Coolant Hazard

- Wear eye protection and rubber gloves when handling engine coolant. If contact with the eyes or skin should occur, flush eyes and wash immediately with clean water.



WARNING

Burn Hazard

- Light fixtures and some of the engine surfaces become very hot during operation and shortly after shutdown.
- Keep hands and other body parts away from hot engine surfaces.
- Handle hot components, such as light fixtures, with heat resistant gloves.



WARNING

California Proposition 65

- The engine exhaust in this product contains chemicals known to the State of California to cause cancer, birth defects, or other reproductive harm.



WARNING

California Proposition 65

- Certain components in this product and related accessories contain chemicals known to the State of California to cause cancer, birth defects, or other reproductive harm. Wash hands after handling.

NOTICE

- Any part which is found defective as a result of inspection or any part whose measured value does not satisfy the standard or limit **MUST** be replaced.
- Always tighten components to the specified torque. Loose parts can cause equipment damage or cause it to operate improperly.
- Follow the guidelines of the Environmental Protection Agency (EPA), Environment Canada (EC) or other governmental agencies for the proper disposal of hazardous materials such as engine oil, diesel fuel and engine coolant.
- The use of authorized replacement Allmand parts is encouraged. The warranty does not cover damage or performance problems caused by the use of parts that are not authorized replacement parts.
- Clean all accumulated dirt and debris away from the body of the equipment and its components before you inspect the equipment or perform preventative maintenance procedures or repairs. Operating equipment with accumulated dirt and debris will cause premature wear of equipment components.
- Never dispose of hazardous materials by dumping them into a sewer, on the ground, or into groundwater or waterways.
- Retrieve any tools or parts that may have dropped inside of the equipment to avoid improper equipment operation.



- If any alert indicator illuminates during equipment operation, stop the engine immediately. Determine the cause and repair the problem before continuing to operate the equipment.





Safety Decals





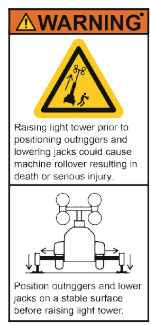

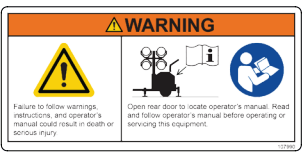

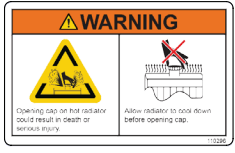



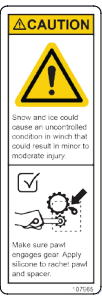

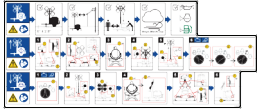

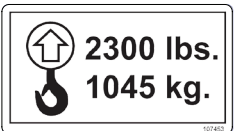

Before operating your unit, read and understand the following safety decals. The cautions, warnings, and instructions are for your safety. To avoid personal injury or damage to the unit, understand and follow all the decals.





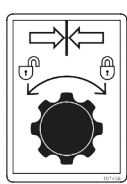



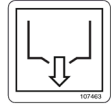



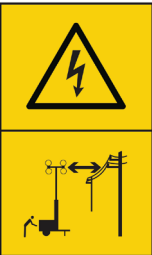

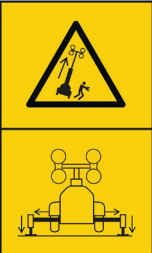
Keep the decals from becoming dirty or torn, and replace them if they are lost or damaged. Also, if a part needs to be replaced that has a decal attached to it, make sure to order the new part and decal at the same time.





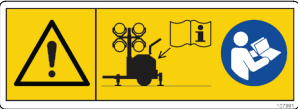

	<p>WARNING</p> <p>If any safety or instructional decals become worn or damaged, and cannot be read, order replacement decals from your dealer.</p>
---	---



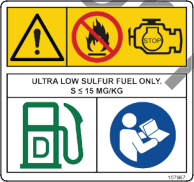

Domestic Models	
<p>DANGER - Entering electrical compartment while equipment is in operation will result in death or serious injury. Shut down equipment before entering electrical compartment.</p> <p>Part No. 107251</p>	
<p>DANGER - Entering electrical compartment while equipment is in operation will result in death or serious injury. Shut down equipment before entering electrical compartment.</p> <p>Part No. 109011</p>	
<p>DANGER - Contacting power lines when raising light tower will result in death or serious injury. Always maintain safe distance from power lines when raising light tower.</p> <p>Part No. 107253-1</p>	

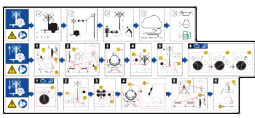
<p>WARNING - Raising light tower without properly positioning the outriggers and lowering jacks could cause machine rollover resulting in death or serious injury. Always position the outriggers and lower jacks on a smooth, flat, and stable surface before raising light tower.</p> <p>Part No. 107253-2</p>	
<p>WARNING - Excessive towing speed could result in death or serious injury. Do not exceed 65mph (105km/h) when towing trailer.</p> <p>Part No. 107464-1</p>	
<p>WARNING - Failure to lower light tower and secure in aligned position could cause light fixtures to detach resulting in death or serious injury. Lower light tower and secure in aligned position before towing trailer.</p> <p>Part No. 107464-2</p>	
<p>WARNING - Failure to follow warnings, instructions and operator's manual could result in death or serious injury. Open rear door to locate operator's manual. Read and follow operator's manual before operating or servicing this equipment.</p> <p>Part No. 107990</p>	
<p>WARNING - Contact with hot exhaust gases and parts could cause death or serious injury. Avoid hot exhaust gases. Keep hands and combustible materials away from hot parts.</p> <p>Part No. 107465</p>	
<p>WARNING - Opening cap on hot radiator could result in death or serious injury. Allow radiator to cool down before opening cap.</p> <p>Part No. 110296</p>	

<p>WARNING - Contact with rotating parts could result in death or serious injury. Keep away from rotating parts.</p> <p>Part No. 107295-1</p>		<p>WARNING - Do not smoke when fueling. Stop engine before refueling.</p> <p>Ultra low sulfur fuel only (<15 MG/KG)</p> <p>Part No. 107967</p>	
<p>WARNING - Opening cap on hot radiator could result in death or serious injury. Allow radiator to cool down before opening cap.</p> <p>Part No. 110295-2</p>		<p>CAUTION - Snow and ice could cause uncontrolled condition in winch that could result in minor to moderate injury. Always check to make sure pawl engages gear, and apply silicone to winch as needed.</p> <p>Part No. 107965</p>	
<p>WARNING - Smoking materials, open flames, or other forms of ignition near the battery could cause explosion resulting in death or serious injury. Keep smoking materials, open flames, or other forms of ignition away from the battery.</p> <p>Part No. 110295-3</p>		<p>Operating Instructions</p> <p>Part No. 110303 (Manual winch models)</p> <p>Part No. 110304 (Electric winch models)</p>	
<p>WARNING - Exposure to corrosive materials could cause result in death or serious injury. Wear protective gloves when handling battery.</p> <p>Part No. 110295-4</p>		<p>Lifting Eye Rating</p> <p>Part No. 107453</p>	
<p>WARNING - Standing under light tower mast and fixtures during lowering operation could result in death or serious injury. Keep bystanders away from light tower during lowering and raising operations.</p> <p>Part No. 108999-1</p>		<p>Tie-Down Point</p> <p>Part No. 107462</p>	
<p>WARNING - Handling light fixtures when they are hot could result in death or serious injury. Keep clear of light fixtures when illuminated or hot.</p> <p>Part No. 108999-2</p>		<p>Forklift Pocket</p> <p>Part No. 107254</p>	
<p>WARNING - Looking at illuminated light fixtures could result in serious injury. Do not look directly at illuminated light fixtures.</p> <p>Part No. 108999-3</p>		<p>Tie-Down Point</p> <p>Part No. 104753</p>	
<p>WARNING - Looking at illuminated light fixtures could result in serious injury. Do not look directly at illuminated light fixtures.</p> <p>Part No. 108999-3</p>		<p>Light Tower Transport Alignment</p> <p>Part No. 107459</p>	
<p>WARNING - Looking at illuminated light fixtures could result in serious injury. Do not look directly at illuminated light fixtures.</p> <p>Part No. 108999-3</p>		<p>Engine Oil Drain</p> <p>Part No. 107973</p>	
<p>WARNING - Looking at illuminated light fixtures could result in serious injury. Do not look directly at illuminated light fixtures.</p> <p>Part No. 108999-3</p>		<p>Fluid Containment Drain</p> <p>Part No. 107463</p>	

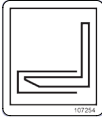

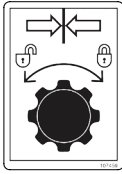

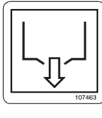



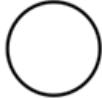

International Models			
<p>DANGER - Entering electrical compartment while equipment is running will result in death or serious injury. Always shut down equipment before entering electrical compartment.</p> <p>Part No. 104480</p>		<p>DANGER - Entering electrical compartment while equipment is running will result in death or serious injury. Always shut down equipment before entering electrical compartment.</p> <p>Part No. 109012</p>	
<p>WARNING - Contacting power lines when raising light tower will result in death or serious injury. Always maintain safe distance from power lines when raising light tower.</p> <p>Part No. 107984-1</p>		<p>WARNING - Contact with hot surface could cause death or serious injury. Always keep hands and combustible materials at a safe distance from hot surface.</p> <p>Part No. 107529</p>	
<p>DANGER - Raising light tower without properly positioning the outriggers and lowering jacks could cause machine rollover resulting in death or serious injury. Always position the outriggers and lower jacks on a smooth, flat, and stable surface before raising light tower.</p> <p>Part No. 107984-2</p>		<p>WARNING - Opening cap on hot radiator could result in death or serious injury. Never open cap on hot radiator. Always allow radiator to cool down before opening cap.</p> <p>Part No. 110309</p>	
<p>WARNING - Excessive towing speed could result in death or serious injury. Do not exceed 65 mph (105 km/h) when towing trailer.</p> <p>Part No. 107985-1</p>		<p>WARNING - Contact with rotating parts could result in death or serious injury. Always keep clear of rotating parts.</p> <p>Part No. 110310-1</p>	
<p>WARNING - Failure to lower light tower and secure in aligned position could cause light fixtures to detach resulting in death or serious injury. Lower light tower and secure in aligned position before towing trailer.</p> <p>Part No. 107985-2</p>		<p>WARNING - Opening cap on hot radiator could result in death or serious injury. Allow radiator to cool down before opening cap.</p> <p>Part No. 110310-2</p>	
<p>WARNING - Failure to lower light tower and secure in aligned position could cause light fixtures to detach resulting in death or serious injury. Lower light tower and secure in aligned position before towing trailer.</p> <p>Part No. 107985-2</p>		<p>WARNING - Smoking materials, open flames, or other forms of ignition near the battery could cause explosion resulting in death or serious injury. Keep smoking materials, open flames, or other forms of ignition away from the battery.</p> <p>Part No. 110310-3</p>	
<p>WARNING - Failure to follow warnings, instructions and operator's manual could result in death or serious injury. Open rear door to locate operator's manual. Read and follow operator's manual before operating or servicing this equipment.</p> <p>Part No. 107991</p>		<p>WARNING - Exposure to corrosive materials could cause result in death or serious injury. Wear protective gloves when handling battery.</p> <p>Part No. 110310-4</p>	

<p>WARNING - Standing under light tower mast and fixtures during lowering operation could result in death or serious injury. Always maintain safe distance from light tower mast and fixtures during lowering operation.</p> <p>Part No. 107980-1</p>	
<p>WARNING - Handling light fixtures when they are hot could result in death or serious injury. Always keep clear of light fixtures when illuminated or hot.</p> <p>Part No. 107980-2</p>	
<p>WARNING - Looking at illuminated light fixtures could result in serious injury. Never look directly at illuminated light fixtures.</p> <p>Part No. 107980-3</p>	
<p>WARNING - Do not smoke when fueling. Stop engine before refueling.</p> <p>Ultra low sulfur fuel only (<15 MG/KG)</p> <p>Part No. 107967</p>	
<p>CAUTION - Snow and ice could cause uncontrolled condition in winch that could result in minor to moderate injury. Always check to make sure pawl engages gear, and apply silicone to winch as needed.</p> <p>Part No. 107532</p>	
<p>Operating Instructions</p> <p>Part No. 110303 (Manual winch models)</p> <p>Part No. 110304 (Electric winch models)</p>	
<p>Lifting Eye Rating</p> <p>Part No. 107453</p>	
<p>Tie-Down Point</p> <p>Part No. 107462</p>	

<p>Forklift Pocket</p> <p>Part No. 107254</p>	
<p>Tie-Down Point</p> <p>Part No. 104753</p>	
<p>Light Tower Transport Alignment</p> <p>Part No. 107459</p>	
<p>Engine Oil Drain</p> <p>Part No. 107973</p>	
<p>Fluid Containment Drain</p> <p>Part No. 107463</p>	

Operation Icons

The following table contains operation icons that may be found on the unit, along with the meaning of each icon.

Icon	Meaning	Icon	Meaning
	On (Power)		Worklight
	Off (Power)		Earth Ground
	Engine Stop		Circuit Breaker
	Engine Run		Disconnecting Circuit Breaker
	Engine Start		Engine Preheat
	Hourmeter		

Features and Controls

The Allmand NIGHT-LITE V-Series light tower trailer is intended for use as a stationary lighting device to illuminate large areas. It may be equipped with outlets that provide 120 volt or 240 volt power at 60 Hertz. The total power output available from the generator is 7kW (Kubota engine) or 6kW (Mitsubishi engine), which may be used at the outlets or in combination with the light fixtures. When all four light fixtures are illuminated they consume 5kW.

Identify the features and controls of the machine by comparing Figures 1 through 3 with the tables following. See **Operation** for detailed information on each feature / control.

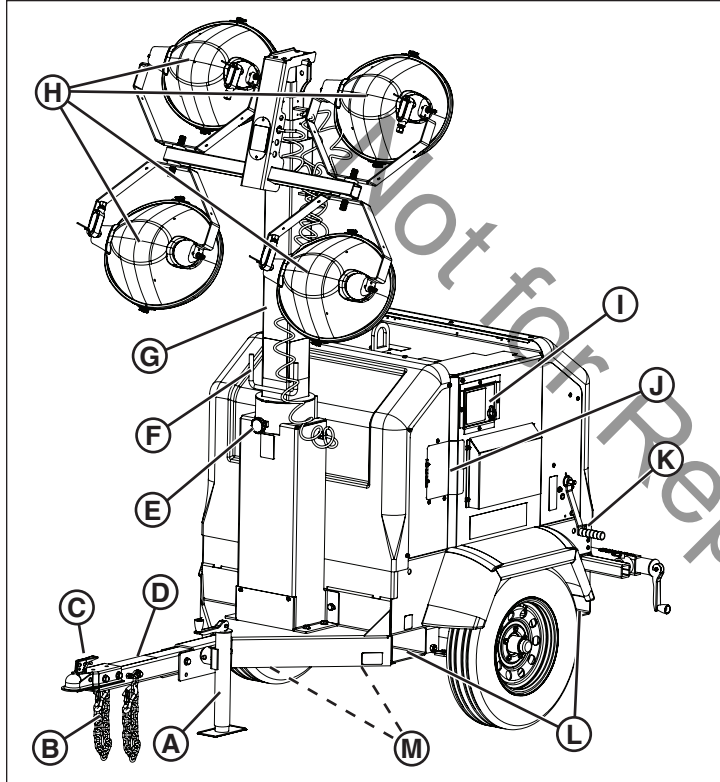

Figure 1

Ref	Description
A	Tongue Jack
B	Safety Chains (2)
C	Trailer Coupler / Lunette Eye
D	Trailer Tongue
E	Light Tower Locking Knob
F	Light Tower Handle
G	Light Tower
H	Light Fixtures (4)
I	Engine Panel Door
J	Fuel Door
K	Light Tower Winch Handle
L	Forklift Pockets (2 each side)
M	Front Tie-Down Points (2)

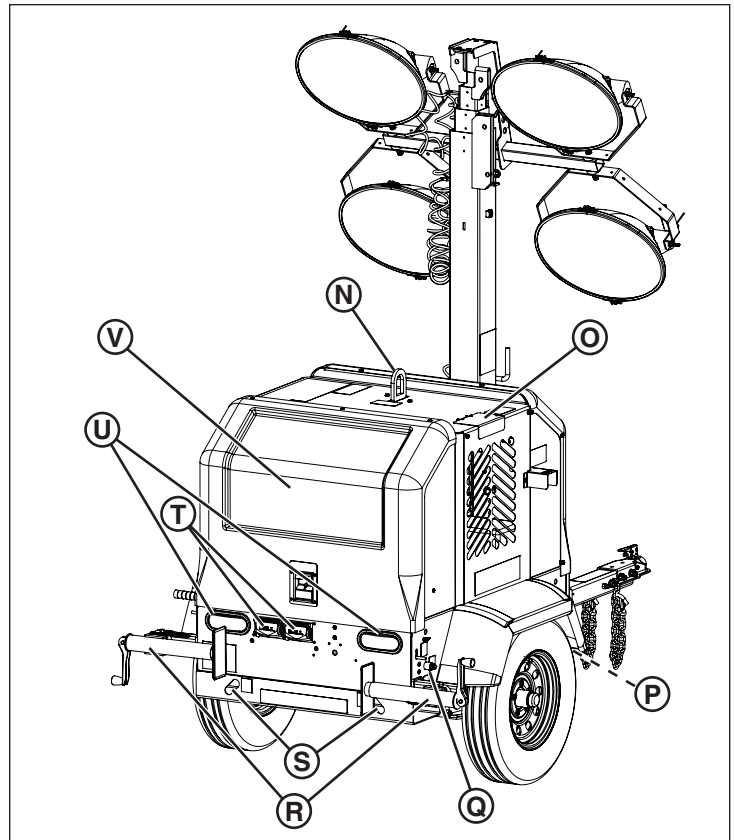

Figure 2

Ref	Description
N	Lifting Ring
O	Radiator Cap Access Door
P	Fluid Containment Drain (under unit)
Q	Engine Oil Drain
R	Outriggers (2)
S	Rear Tie-Down Points (2)
T	Auxiliary AC Outlets
U	Taillights (2)
V	Rear (Engine Compartment) Door

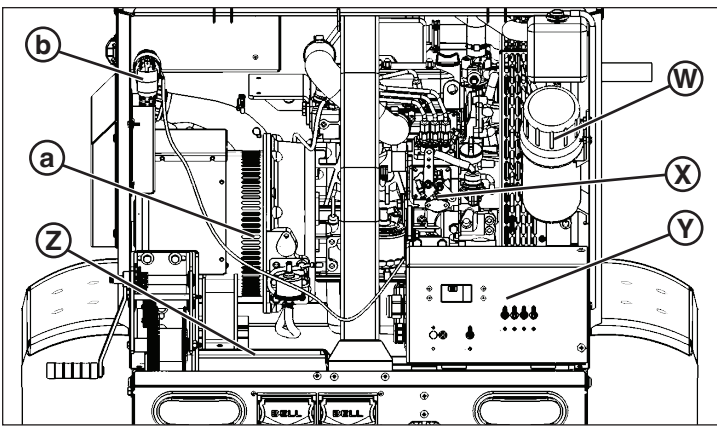

Figure 3

Ref	Description
W	Manual Storage Container
X	Engine
Y	Light / AC Outlet Circuit Breaker Control Panel
Z	Battery
a	Generator
b	Twistlock to RV Adapter

Preparing The Light Tower Trailer For Use

If the light tower trailer has been stored or idle for a period of time, follow these steps to prepare the NIGHT-LITE V-Series light tower trailer for use.



WARNING

Operating or towing a machine with worn, damaged or missing parts can result in death or serious injury. Always replace worn, damaged or missing parts promptly. Do not operate or tow this machine until all worn, damaged or missing parts have been replaced, and proper operation of the machine has been verified.

NOTICE

The use of authorized replacement Allmand parts is encouraged. The warranty does not cover damage or performance problems caused by the use of parts that are not authorized replacement parts.

1. Check that a copy of the Operator's Manual is with the light tower trailer in the manual storage container.
2. Check that all safety decals are legible and in place on the light tower trailer. See **Safety Decals** in the **Operator Safety** section.
3. Check the light tower trailer for proper operation:
 - a. Check to be sure the trailer tongue is secured in either the park or towing position. See **Trailer Tongue**.

- b. Use an appropriate means to safely support the trailer tongue. Check that the tongue jack operates properly, and that the jack can be secured in the transport position as well as the trailer support position. See **Operating the Tongue Jack**.
- c. Check that the outriggers operate properly, and that each one is secured in the transport position. See **Leveling and Stabilizing the Light Tower Trailer** in the **Operation** section.
- d. Check the winch and cable system for proper operation, and that the cable is not frayed or damaged.
- e. Check that the trailer coupler operates properly, and that it is securely fastened to the light tower trailer tongue. See **Using The Trailer Coupler**.
- f. Check that the safety chains are properly secured to the light tower trailer tongue, and check the safety chains and hooks for damage. Replace damaged safety chains and hooks.
- g. Check the condition and inflation pressure of the tires. See **Specifications**.



WARNING

Towing a trailer with worn, damaged or underinflated tires could result in death or serious injury. Always replace worn or damaged tires promptly. Always keep tires inflated to proper cold tire inflation pressure.

4. Check the engine oil level and replenish as necessary. See **Maintenance**.
5. Check the engine cooling system and replenish as necessary. Make sure that the coolant overflow bottle is at least half full of coolant. See **Maintenance**.
6. Check the air filter for damage and replace as necessary. Check the engine air intake system and make sure all connections are air tight.
7. Check the battery for adequate charge. The light tower trailer is equipped from the factory with a 12 volt battery. Use a 12 volt battery charger to bring the battery back to full charge. See **Maintaining the Battery** in the **Maintenance** section.
8. If the trailer was stored with the battery disconnected, reconnect the battery.
9. Check that there is sufficient fuel in the fuel tank. See **Engine Operation - Pre-Start Checks** in the **Operation** section for detailed information on checking and adding fuel.
10. Check that the engine starts and runs properly. See **Engine Operation** in the **Operation** section.
11. Check that each of the light fixtures illuminates properly. See **Operating The Tower Lights** in the **Operation** section.

12. Check the GFCI using the “Test” button. See **Auxiliary AC Outlets** in the **Operation** section.

Towing the Light Tower Trailer

Preparing The Light Tower Trailer For Towing



WARNING

Towing a trailer with an underrated tow vehicle or an underrated or undersized hitch could result in death or serious injury. Always use a tow vehicle that has a rated towing capacity that exceeds the Gross Vehicle Weight Rating (GVWR) of the trailer, and is equipped with the appropriate size tow hitch rated for the GVWR of the trailer.



WARNING

Operating or towing a machine with worn, damaged or missing parts can result in death or serious injury. Always replace worn, damaged or missing parts promptly. Do not operate or tow this machine until all worn, damaged or missing parts have been replaced, and proper operation of the machine has been verified.

1. Check to be sure the engine is shut down.

NOTE: Lights will automatically shut down prior to engine shutdown.

2. Check to be sure the light tower is fully lowered.
3. Check to be sure the light tower is rotated into the transport position, and the locking knob is securely tightened.
4. Check to be sure the light fixtures are swiveled into the transport position.



WARNING



Burn Hazard

- The light fixtures become extremely hot during use.
- Always use caution and heat-resistant gloves when handling the lights, or allow the lights to sufficiently cool down before handling.

5. Check to be sure the outriggers and stabilizer jacks are retracted and locked in the transport position.
6. Check to be sure the engine compartment cover is closed and latched.
7. Check to be sure the trailer tongue is pivoted down and secured in the towing position. See **Trailer Tongue**.
8. Check to be sure the tow vehicle and trailer hitch are rated to tow the unit. See **Light Tower Trailer Weight**.

NOTE: Consult the tow vehicle and trailer hitch manuals for rated towing capacities.

9. Connect the trailer to the tow vehicle hitch. Check the trailer coupler / lunette eye for damage, and that it is

securely connected to the tongue. See **Connecting The Light Tower Trailer To The Tow Vehicle**.

10. Check to be sure the safety chains are properly secured to the trailer tongue, and check the safety chains and hooks for damage. Replace as needed.
11. Check to be sure the tow vehicle lighting connector will mate with the trailer lighting connector. Check the trailer lighting connector and wires for damage. Repair or replace as needed.
12. Check the condition and inflation pressure of the tires. See **Checking the Tire Pressure** in the **Maintenance** section.



WARNING

Towing a trailer with worn, damaged or underinflated tires could result in death or serious injury. Always replace worn or damaged tires promptly. Always keep tires inflated to proper cold tire inflation pressure.

13. Check to be sure the wheel chocks are removed from the front and rear of each wheel.

Trailer Tongue

The light tower trailer comes equipped with a pivoting trailer tongue that can be raised during storage or trailer-transporting.



WARNING

Do not attempt to pivot the trailer tongue up when the light tower trailer is connected to a tow vehicle. Death or serious injury could result.



WARNING

Do not attempt to pivot the trailer tongue up unless the front of the unit is supported by the tongue jack. Death or serious injury could result.

To pivot the trailer tongue up (park position)

1. Check to be sure the front of the unit is supported by the tongue jack. See **Operating The Tongue Jack**.
2. Remove the rear hardware (**A**, Figure 4) securing the trailer tongue (**B**) in the towing position (**C**).
3. Pivot the trailer tongue up to the park position (**D**, Figure 4). Secure with the removed hardware, inserting into the park position locking hole (**E**). Be sure to tighten the hardware.



WARNING

Failure to secure the trailer tongue in the park position could cause the trailer tongue to drop, resulting in death or serious injury. Always secure the trailer tongue in the park position with the securing hardware.

To pivot the trailer tongue down (towing position)

1. Be sure the front of the unit is supported by the tongue jack. See **Operating The Tongue Jack**.
2. Remove the hardware securing the trailer tongue in the park position (E, Figure 4).
3. Pivot the trailer tongue down to the towing position (C, Figure 4). Secure with the removed hardware (A). Be sure to securely tighten the hardware.



WARNING

Failure to secure the trailer tongue in the towing position could cause the front of the light tower trailer to collapse, resulting in death or serious injury. Always secure the trailer tongue in the towing position with the securing hardware.

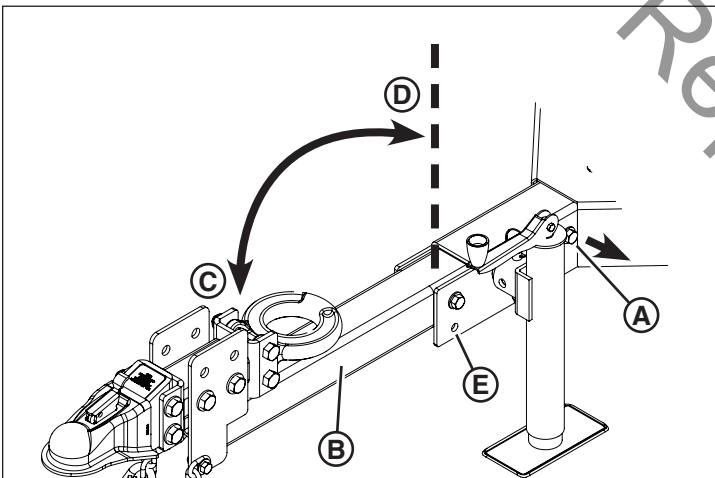

Figure 4

Connecting The Light Tower Trailer To The Tow Vehicle

1. Place wheel chocks (not supplied) against the front and back of each wheel on both sides of the light tower trailer.
2. Check to be sure the trailer tongue is pivoted down and secured in the towing position. See **Trailer Tongue**.
3. Determine whether the towing vehicle has a ball hitch or a pintle hitch. Reverse the trailer hitch bar if needed. See **Using The Trailer Coupler / Lunette Eye**.
4. Use the tongue jack to raise the trailer coupler or lunette eye above the tow vehicle's hitch ball or pintle hook. See **Operating The Tongue Jack**.

4. Position the tow vehicle's hitch ball or pintle hook under the trailer coupler or lunette eye.
5. Lower the trailer coupler or lunette eye onto the hitch ball or pintle hook with the tongue jack.
6. Lock the trailer coupler or pintle hitch. See **Using The Trailer Coupler / Lunette Eye**.
7. Attach the safety chains (A, Figure 5) to the tow vehicle's hitch frame. Cross the chains under the tongue as shown. Leave enough slack in the chains to allow for turns, but not so much that the chains will contact the road surface.
8. Connect the trailer lighting connector (B, Figure 5) to the tow vehicle lighting connector. Make sure the trailer lighting harness has adequate length to prevent disconnection when turning, but not so much length that the harness will contact the road surface. Once connected, check the stop, turn signal, tail, side marker and license plate lamps for proper operation.
9. Fully raise the tongue jack foot, then retract the tongue jack into the transport position. See **Operating The Tongue Jack**.
10. Remove the wheel chocks from both sides of the light tower trailer wheels.

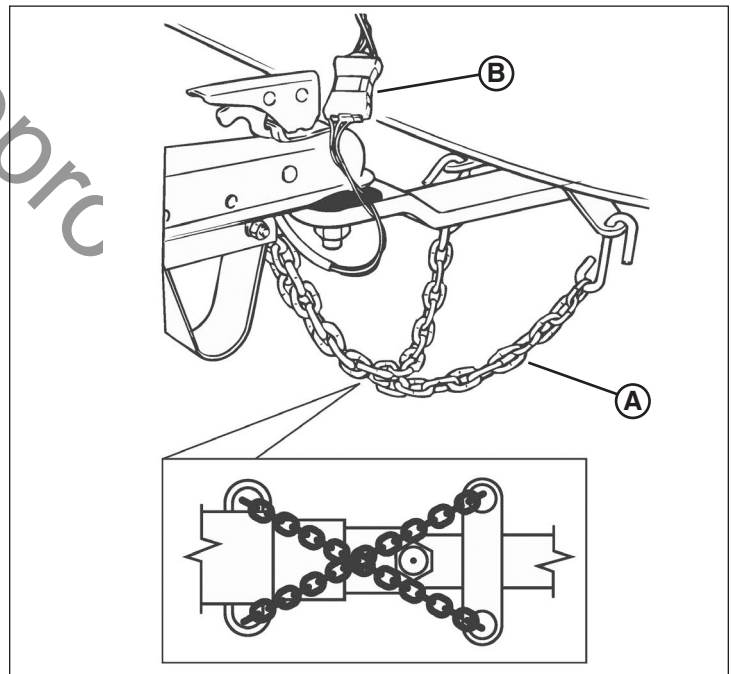

Figure 5

Operating The Tongue Jack

The unit is equipped with a tongue jack to support the front of the light tower trailer and to level the trailer front-to-rear.

To deploy the tongue jack

1. Remove the jack locking pin (A, Figure 6), rotate the tongue jack into the operating position (B), and install the jack locking pin fully through the top and bottom holes in the jack and tongue.



WARNING

Failure to secure the tongue jack in the operating position with the jack locking pin could cause the front of the light tower trailer to collapse, resulting in death or serious injury. Always be sure to secure the tongue jack in the operating position with the jack locking pin.

2. Unfold the crank handle (C, Figure 6).

To lower the tongue jack foot (raise the front of the trailer)

- Turn the jack handle clockwise (D, Figure 6) to lower the jack foot (E) and raise the front of the light tower trailer.

To raise the tongue jack foot (lower the front of the trailer)

- Turn the jack handle counter-clockwise (F, Figure 6) to raise the jack foot (G) and lower the front of the light tower trailer.

To retract the tongue jack

1. Be sure the trailer tongue is secured in the towing position. See **Trailer Tongue**.
2. Use an appropriate means to support the trailer tongue.



WARNING

Retracting the tongue jack without supporting the trailer tongue could result in death or serious injury. Always be sure the trailer tongue is safely supported by appropriate means prior to retracting the tongue jack.

3. Fully raise the tongue jack foot.
4. Fold the crank handle (H, Figure 6).
5. Remove the jack locking pin (A, Figure 6), rotate the jack into the transport position (I), and install the jack locking pin fully through the top and bottom holes in the jack and trailer tongue.

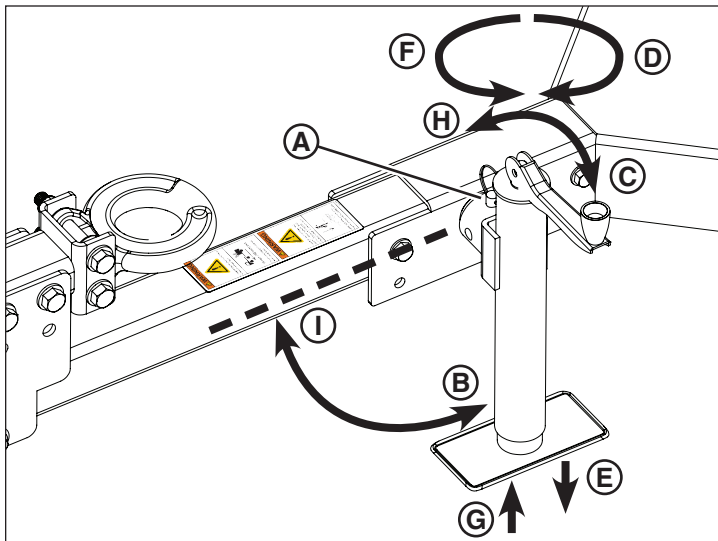

Figure 6

Using The Trailer Coupler / Lunette Eye

The trailer is equipped with a trailer coupler for a ball hitch and a lunette eye for a pintle hitch.

To reverse the trailer coupler / lunette eye

1. Remove the hardware (C, Figure 7) securing the trailer hitch bar to the trailer tongue. Discard the nylock nuts.
2. Reverse the trailer hitch bar so either the trailer coupler (A, Figure 7) or lunette eye (B) is facing forward. Install the hardware removed in Step 1 into the lower or upper set of holes in the trailer tongue, securing with new nylock nuts. Tighten to 110 lb-ft (149 Nm).



WARNING

Failure to use new, properly torqued nylock nuts to secure the hitch bar to the trailer tongue could result in death or serious injury. Always use new, properly torqued nylock nuts when securing the hitch bar to the trailer tongue.

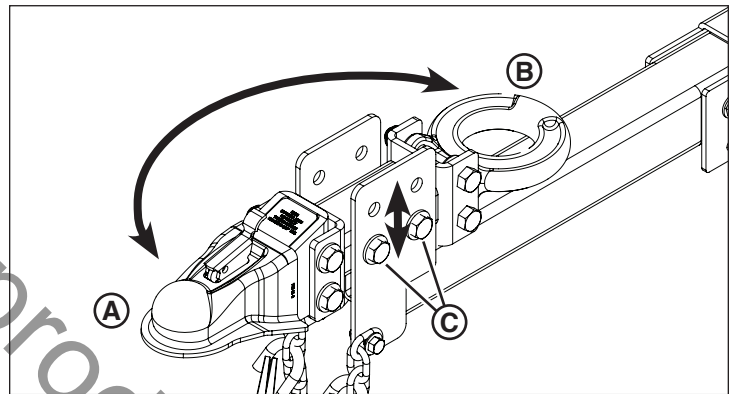

Figure 7

Trailer coupler

To couple the trailer to the tow vehicle

1. Lift up and pull back on the locking latch (A, Figure 8) of the trailer coupler.
2. Lower the trailer coupler onto the vehicle ball hitch. Make sure the hitch ball (B, Figure 8) is completely engaged in the coupler socket (C).
3. Push the locking latch forward and down. (It is self-locking.) If preferred, insert a padlock through the latch hole (D, Figure 8) for added security.
4. Check to be sure the coupler is securely attached to the ball hitch.

To uncouple the trailer from the tow vehicle

1. Remove the padlock (if installed) from the trailer coupler latch (D, Figure 8).
2. Lift the trailer coupler (A, Figure 8) latch up and back.

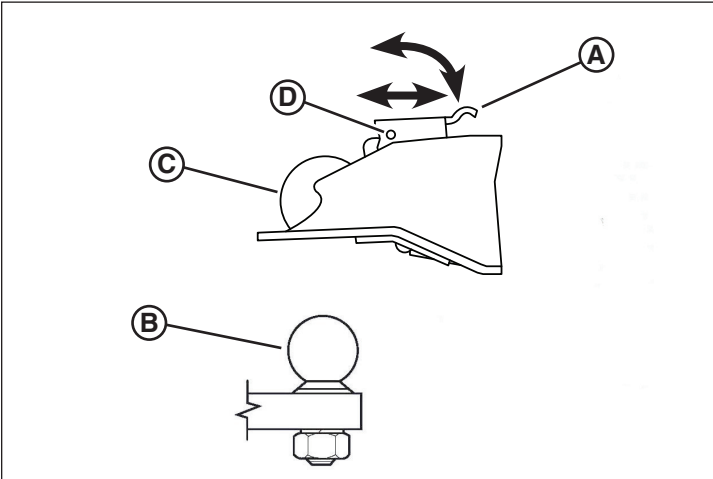

Figure 8

Lunette eye

To couple the trailer to the tow vehicle

1. Remove the locking pin (A, Figure 9, if equipped) from the pintle hitch (C).
2. Pull up on the latch (B, Figure 9), to open the pintle hitch.
3. Lower the lunette eye (D, Figure 9) into the pintle hook (E).
4. Close the pintle hitch, making sure the latch is secured.
5. Install the locking pin (if equipped).

To uncouple the trailer from the tow vehicle

1. Remove the locking pin (if equipped) from the pintle hitch.
2. Pull up on the latch to open the pintle hitch.
3. Remove the lunette eye from the pintle hook.

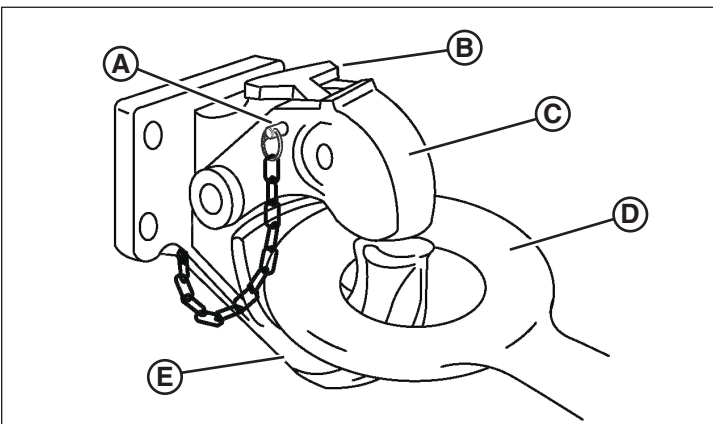

Figure 9

Light Tower Trailer Weight



WARNING

Towing the light tower trailer when it is loaded beyond the Gross Vehicle Weight Rating (GVWR) could result in death or serious injury. Always maintain a gross vehicle weight less than the GVWR stated on the serial plate and in the **Specifications** section of this manual.

The light tower trailer is an SAE Class 2 trailer, with a Gross Vehicle Weight Rating (GVWR) as stated on the serial plate and in the **Specifications** section of this manual. Do not exceed the GVWR by attempting to carry additional tools or equipment. Do not carry riders. See **Safety**.

Towing The Light Tower Trailer



WARNING

Excessive speed when towing the trailer could result in death or serious injury. Always maintain a safe towing speed for road conditions. Never exceed 65 MPH (105 km/h) when towing the trailer.



WARNING

Rollover Hazard

Do not make sharp turns at high speeds when towing the light tower trailer. This could cause the light tower trailer to roll over, resulting in death, serious injury, or equipment damage.

The rated maximum highway towing speed for the light tower trailer is 65 MPH (105 km/h). Be sure to check your state or province laws regarding maximum legal towing speeds for trailers.

When towing the trailer off-highway or on rougher terrain, the maximum towing speed is 20 MPH (32 km/h). Slower speeds may be required for very rough terrain.

Tow the light tower trailer with the engine and lights shut down.

Do not carry riders.

Disconnecting The Light Tower Trailer From The Tow Vehicle

1. Select a firm, level and stable surface at the work site. See **Work Site Considerations** in the **Operation** section.
2. Position the light tower trailer as desired with the tow vehicle.
3. Chock the wheels on both sides of the trailer.

! WARNING

Crush Hazard

Attempting to move or position the light tower trailer by manually pushing or pulling it could present a crush hazard resulting in death or serious injury. Always position the trailer with the tow vehicle, chock the wheels, and lower the tongue jack before uncoupling the trailer from the tow vehicle.

4. Disconnect the trailer lighting connector from the tow vehicle lighting connector.
5. Rotate the tongue jack into the operating position. See **Operating The Tongue Jack**.
6. Lower the tongue jack foot to support the front of the light tower trailer. See **Operating The Tongue Jack**.
7. Uncouple the trailer coupler from the tow vehicle. See **Using The Trailer Coupler / Lunette Eye**.
8. Use the tongue jack to raise the trailer coupler or lunette eye above the tow vehicle's hitch ball or pintle ring.
9. Disconnect the safety chains from the tow vehicle's hitch frame.
10. Move the tow vehicle clear of the light tower trailer.
11. If desired, pivot the trailer tongue up to the park position. See **Trailer Tongue**.

Transporting On A Trailer

The unit is equipped with four (4) tie-down points. See **Features and Controls** for tie-down point locations.

Always secure the light tower trailer with appropriate chains or straps. Do not apply more than 600 pounds (272 kg) force on the chains or straps.

The truck operator is responsible for securing the load properly to his transporting trailer.

NOTE: When transporting on a trailer, position the two top light fixtures straight down to provide additional overhead clearance. See Figure 10.

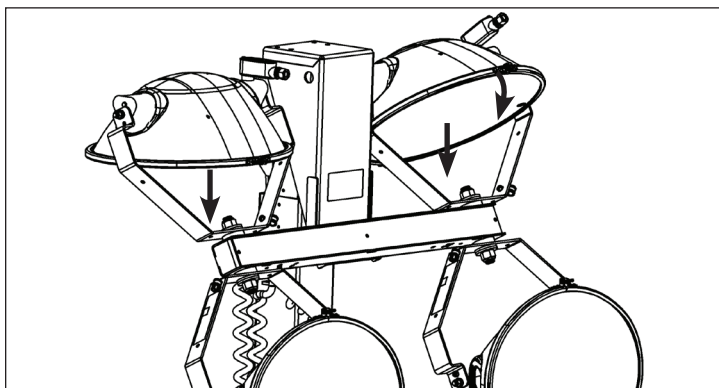

Figure 10

Lifting The Light Tower Trailer

! WARNING

Attempting to lift the light tower trailer with a lifting device that is underrated or damaged could result in death or serious injury. Always make sure the lifting device is rated to lift the weight of the light tower trailer. Make sure the lifting device is not damaged and is in operable condition before beginning the lift.

! WARNING

Standing or walking under elevated equipment could result in death or serious injury. When elevating or lifting the light tower trailer, always keep clear of the area around and under the light tower trailer, and do not allow others in the area.

General Lifting Guidelines

- Before lifting, lower the light tower and shut down the engine. See **Pre-Transport Check List**.
- Always be sure the lifting device you are using is in good condition and rated to exceed the Gross Vehicle Weight Rating (GVWR) of the light tower trailer. See **Light Tower Trailer Weight**.
- Always acquire assistance when using a forklift, crane or hoist and when unloading.
- Use only the lifting eye to lift or hoist the unit with a hoist or crane.
- Use only shackles or a locking-type hook when lifting.
- Do not stand or walk under the unit when lifted. Keep others away.

Lifting Eye

The light tower trailer is equipped with one lifting eye, located at the top center of the unit (A, Figure 11). Use only this lifting eye when attempting to lift the light tower trailer.

Use a lifting device with a lift rating that exceeds the Gross Vehicle Weight Rating (GVWR) of the light tower trailer. See **Light Tower Trailer Weight**.

The lifting eye is rated for 2300 pounds (1045 kg), and is intended to carry the weight of the light tower trailer only, with no additional weight.

The light tower trailer is not intended to be suspended for long periods of time.

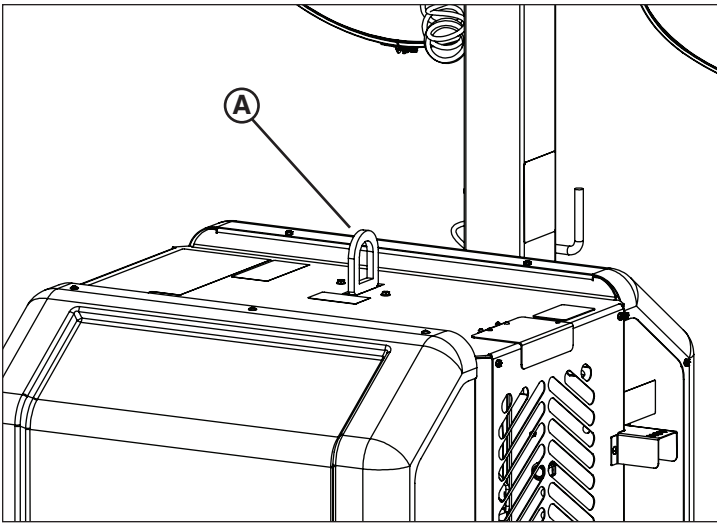

Figure 11

Lifting The Light Tower Trailer With A Forklift

The light tower trailer is equipped with two forklift pockets (B, Figure 12) on either side of the unit.

Use a forklift with a rated lifting capacity greater than the weight of the light tower trailer. See **Light Tower Trailer Weight**.

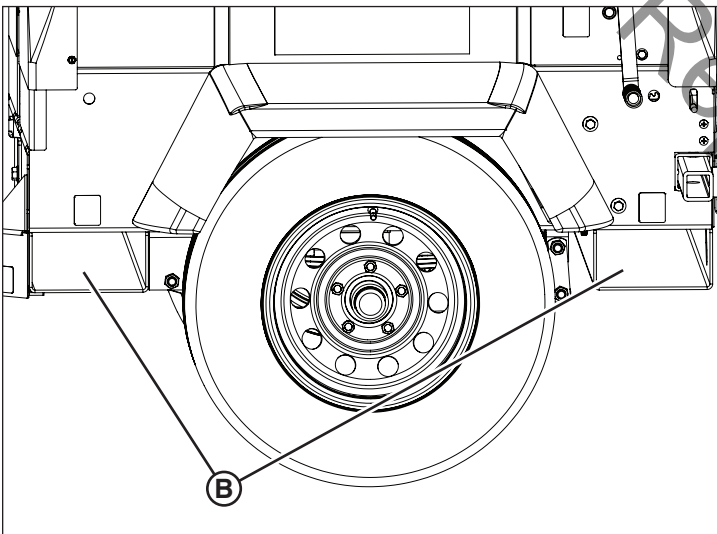

Figure 12

Operation

Before performing any operation procedures, read **Safety**.

Work Site Safety Considerations

It is the operator's responsibility to ensure that the light tower trailer is properly and safely positioned at the work site. Follow state, province and federal rules, as well as rules or instructions for the work site.

Height



DANGER

Electrocution Hazard

- Raising the light tower in the presence of electrical power lines will result in death or serious injury. Always check overhead wires and obstructions before raising or lowering the light tower.
- Always follow the rules or regulations for your work-site, and state, province and national electric code for maintaining a safe distance from overhead wires.

The work site must be clear of overhead obstructions such as power lines, trees, etc. Keep in mind the maximum height of the light tower when fully raised. See **Specifications**.

Ground Surface



WARNING

Rollover Hazard

Positioning the light tower trailer on soft, unstable or unlevel ground could cause trailer rollover, resulting in death or serious injury. Always position the trailer on a firm, level and stable surface and deploy the outriggers before raising the light tower.

- Do not set up the light tower trailer on an incline of more than 2.8° (5% grade) front-to-back and side-to-side.
- Do not position or set up the light tower trailer on unlevel or unstable ground. Set up on smooth, flat and solid ground surfaces only.

Wind



WARNING

Rollover Hazard

- Operating with the light tower raised in winds exceeding 50 mph (80 km/h) can cause trailer tip-over resulting in death or serious injury. Do not operate with the light tower raised in winds exceeding 50 mph (80 km/h).

When the light tower is in the operating position it is located in the middle of a three-point outrigger system for optimum balance and stability. This system was engineered to allow

the light tower to remain operational in sustained winds of 50 mph (80 km/h) with the light tower extended to full height and the outriggers in position on a firm, level surface.

Leveling and Stabilizing the Light Tower Trailer



WARNING

Rollover Hazard

Positioning the light tower trailer on soft, unstable or unlevel ground could cause trailer rollover, resulting in death or serious injury. Always position the trailer on a firm, level and stable surface and deploy the outriggers before raising the light tower.

1. Position the light tower trailer on an adequate work site. See **Work Site Safety Considerations**.
2. Block each wheel on each side with a suitable wheel chock (A, Figure 13).

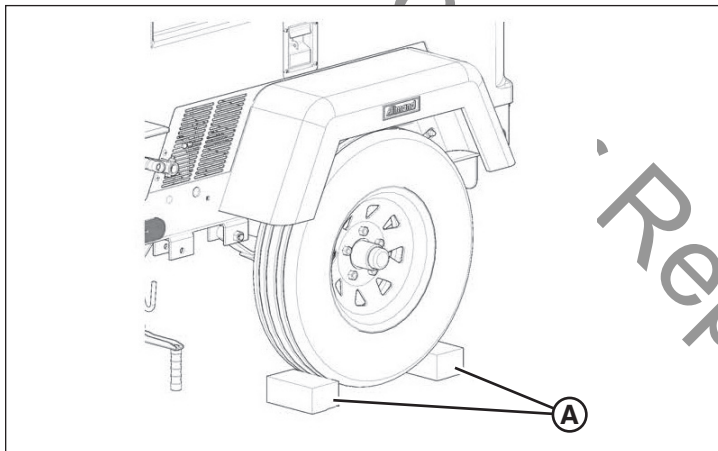

Figure 13

3. Level the light tower trailer using the tongue jack. See **Operating the Tongue Jack** in the **Transporting** section.
4. Deploy the outriggers:
 - a. Lift the outrigger locking pin (A, Figure 14).
 - b. Slide the outrigger (B, Figure 14) out until the pin locks the outrigger in the operating position.
 - c. Remove the stabilizer jack locking pin (C, Figure 14), rotate the jack into the operating position (D), and install the stabilizer jack locking pin fully through the top and bottom holes in the jack and outrigger.
 - d. Unfold the handle (E, Figure 15) of the stabilizer jack, then turn clockwise (F) to lower the jack foot (G) until firmly planted on the work site surface.
 - e. Repeat for the opposite outrigger and stabilizer jack.
 - f. Level the light tower trailer front to back and side to side using the jacks.

5. To retract the outriggers:

- a. Fully raise the stabilizer jack foot by turning the jack handle counterclockwise.
- b. Fold the handle.
- c. Remove the stabilizer jack locking pin, rotate the jack into the transport position, and install the stabilizer jack locking pin fully through the top and bottom holes in the jack and outrigger.
- d. Lift the outrigger locking pin, and slide the outrigger in until the pin locks the outrigger in the transport position.
- e. Repeat for the opposite stabilizer jack and outrigger.



WARNING

Rollover Hazard

Failure to deploy the outriggers before raising the light tower could cause the light tower trailer to tip over, resulting in death or serious injury. Always deploy the outriggers before raising the light tower.



WARNING

Rollover Hazard

- Stabilizer jacks must be supported by a flat, level solid ground surface.

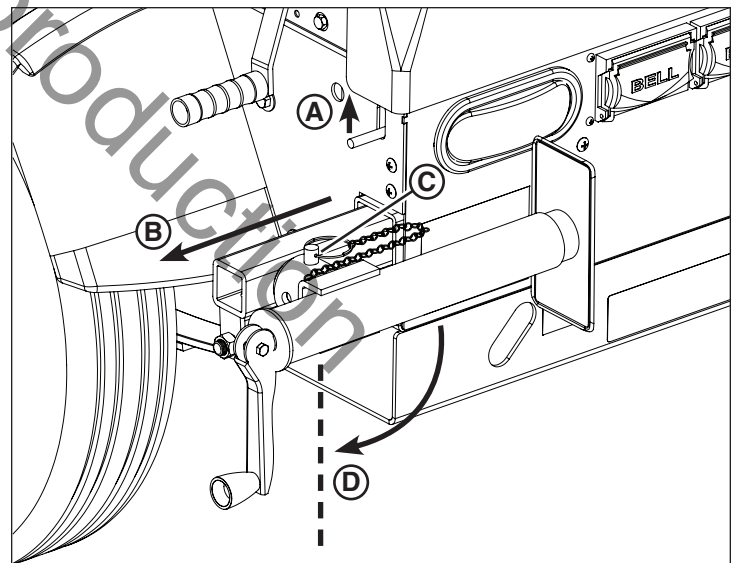

Figure 14

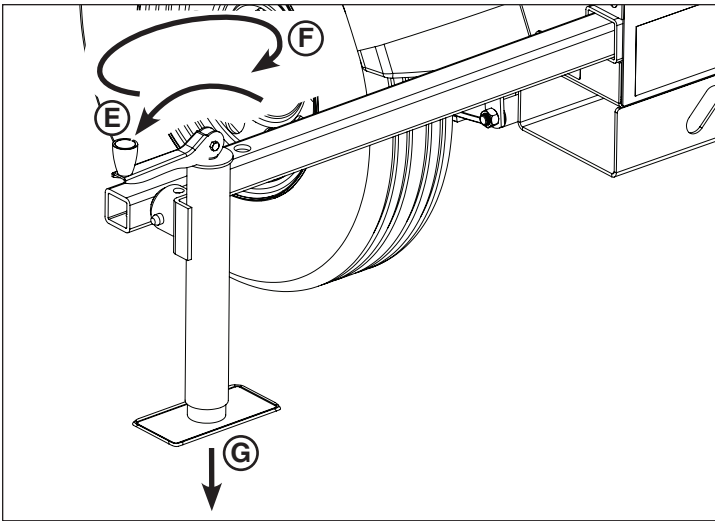

Figure 15

Fueling The Unit



Fire Hazard

Attempting to fuel the light tower trailer with the engine running could cause fire resulting in death or serious injury. Always make sure the engine is shut down before adding fuel to the fuel tank.

The light tower trailer is equipped with a single fuel tank having a capacity of 45 gallons (170 L).

1. Unlock and open the fuel door (A, B, Figure 16) on the left side of the unit.
2. Remove the fuel cap (C, Figure 16) and add fuel to the tank. See **General Fuel Information** in the **Maintenance** section for fuel recommendations.
3. Close and secure the fuel door. The fuel door can be padlocked for added security.

NOTICE

Using engine fuels other than those recommended by the engine manufacturer could cause damage to your engine or its emission control system resulting in voiding the engine manufacturer's warranty. Always read and follow the engine manufacturer's fuel recommendations.

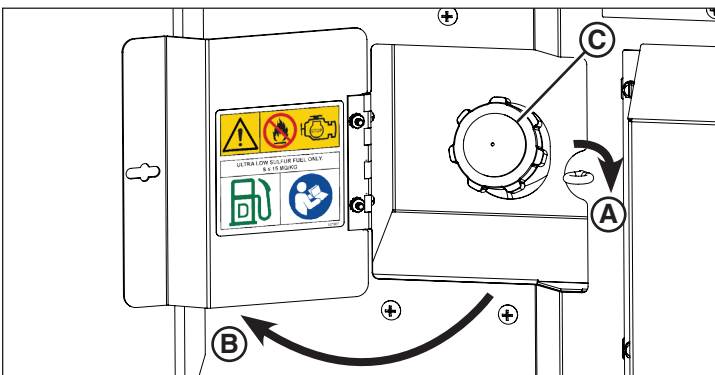

Figure 16

Preparing To Operate The Unit

Follow these steps to prepare the light tower trailer for operation:

1. Level the light tower trailer front to back with the tongue jack. See **Leveling And Stabilizing The Light Tower Trailer**.
2. Unlatch and open the engine compartment cover. (The cover is equipped with a locking support rod.) Check the following:
 - a. Remove the dipstick from the engine and check the engine oil level. Maintain engine oil level between the "Full" and "Add" marks on the dipstick. Replenish as necessary. See **Engine Oil** in the **Maintenance** section.
 - b. Check the engine coolant recovery bottle. Keep engine coolant in the recovery bottle between 1/3 and 2/3 full. Open the radiator cap access door (see **Features and Controls**), remove the radiator cap, and check the coolant level. Replenish as necessary. See **Engine Coolant** in the **Maintenance** section for detailed information on engine coolant.



Burn Hazard

Rapid release of hot coolant under pressure could result in death or serious injury. Use extreme caution when opening the radiator cap, and always wear eye protection and heat resistant gloves.

3. On the support rod, move the red safety release lever to the side to allow the cover to close.
4. Check the fuel level in the fuel tank and replenish as necessary. See **Fueling The Unit**.

Operating The Engine

To start the engine:

1. Open the engine panel door (A, Figure 17).
2. Turn the ignition switch (B, Figure 17) on the control panel counterclockwise to PREHEAT (C). Hold for approximately 20 seconds.
NOTE: Do not hold for longer than 20 seconds.
2. Turn the switch clockwise past RUN (D, Figure 17) to START (E).
3. Once the engine starts, release the switch; it will return to the RUN position.

NOTE: The electrical system is designed with a 20-second delay after the engine starts before the lights and auxiliary AC outlets will operate.

NOTE: The hourmeter (G, Figure 17) indicates the total hours of engine operation.

Notice

Do not operate the starter for more than 10 seconds. Allow 30 seconds between starting attempts. Possible starter damage could result from excessive starting attempts.

Notice

Engaging the starter while the flywheel is rotating could result in damage to the starter or flywheel ring gear.

If the engine has run out of fuel, you will need to bleed the air from the fuel system. See 'Bleeding The Fuel System' in the Engine Operator's Manual.

For further information on starting your engine, see the Engine Operator's Manual.

To shut down the engine:

1. Turn the ignition switch counterclockwise to the OFF position (F, Figure 16). Close and secure the engine panel door. (The engine panel door can be padlocked for added security.)

NOTE: The electrical system automatically turns off the tower lights before the engine shuts down to protect the capacitors.

Using The Block Heater

The light tower trailer can be equipped with an optional electric, frost plug style block heater. The block heater is 120 volts AC, 60Hz, 3.3 amp. Use a grounded (3 prong) extension cord to connect the block heater to an appropriate electric power source.

For the Kubota engine, the block heater is located on the right side when viewed from the fan side.

For the Mitsubishi engine, the block heater is located on the left side when viewed from the fan side, in the core plug nearest the bell housing.

Automatic Engine Shutdown System

The engine is equipped with an automatic engine shutdown system to prevent engine damage in the event of a low oil or overheat condition.

If the engine has automatically shut down, locate the source of the failure and repair before restarting the engine.

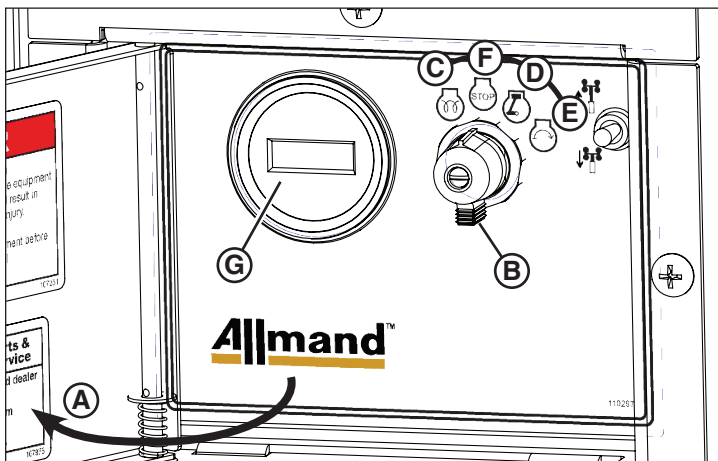

Figure 17

Light Tower Operation

Adjusting The Lights



Burn Hazard

- Adjusting the lights while illuminated could result in death or serious injury. Always adjust the lights with the engine shut down.



Burn Hazard

- The light fixtures become extremely hot during use.
- Always use caution and heat-resistant glove when handling the lights or allow the lights to sufficiently cool down before handling.

Adjusting The Light Fixtures

NOTE: The light fixtures must be adjusted before raising the light tower.

1. Shut down the engine. See **Operating The Engine**. Wait 10 minutes for the lights to cool.
2. Manually adjust each fixture (up/down/left/right) to suit lighting needs. See Figure 18.
3. When lighting operations are complete, adjust the light fixtures to the transport position, with the fixtures facing straight back toward the rear of the light tower trailer. See Figure 18.

*NOTE: When transporting on a trailer, position the two top light fixtures straight down to provide additional overhead clearance. See **Transporting On A Trailer** in the **Preparing The Light Tower Trailer For Use** section.*

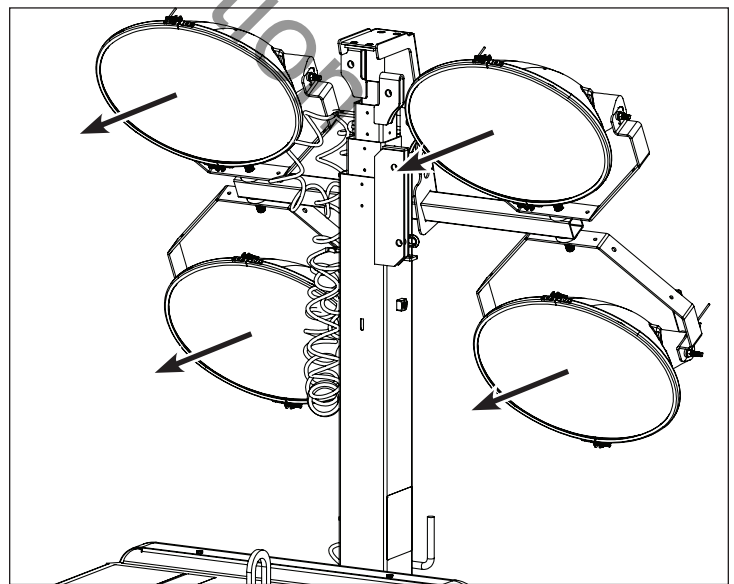

Figure 18

Rotating The Light Tower

CAUTION

Rotating the light tower will cause the light fixtures to swing, and could result in mild to moderate injury. Be careful to rotate the tower slowly, and be aware of the light fixtures while rotating the tower.

1. Shut down the engine. See **Operating The Engine**. Wait 10 minutes for the lights to cool.
2. Loosen the light tower locking knob (A, Figure 19).
3. Using the handles (B, Figure 19), rotate the light tower in the desired direction.
4. Tighten the light tower locking knob.

WARNING

Failure to tighten the light tower locking knob may cause the light fixtures to swing inadvertently, especially in windy conditions or during transport, and could result in death or serious injury. Always tighten the tower locking knob securely after rotating the light tower.

5. When lighting operations are complete, rotate the light tower to the transport position: Align the light tower tab (C, Figure 19) with the front center of the light tower base. Be sure to tighten the light tower locking knob securely.

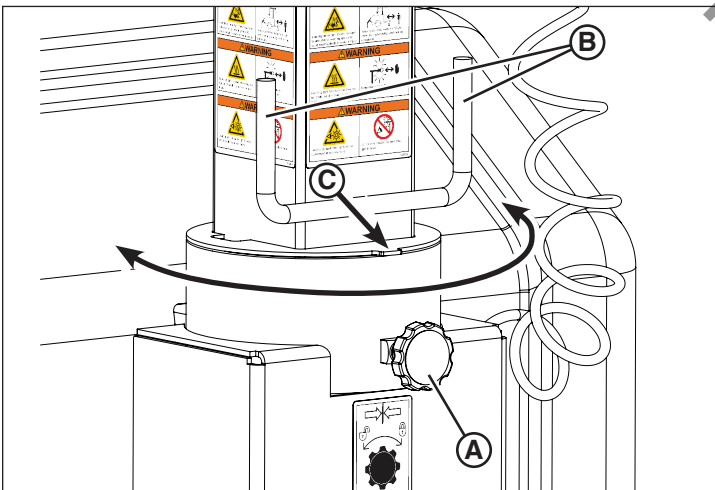

Figure 19

Raising and Lowering The Light Tower

DANGER

Electrocution Hazard

- Raising the light tower in the presence of electrical power lines will result in death or serious injury. Always check overhead wires and obstructions before raising or lowering the light tower.

WARNING

Rollover Hazard

- Before raising, lowering or operating the tower lights, the trailer must be set up, properly leveled and stabilized. See **Pre-Operation Setup**.

WARNING

Crush Hazard

- Standing under the light tower while raising or lowering could result in death or serious injury. Ensure that there are no persons near the light tower when raising or lowering the light tower.

Raising the Light Tower - Winch

1. Shut down the engine. See **Operating The Engine**. Wait 10 minutes for the lights to cool.
2. Before raising the light tower, adjust the tower lights to the desired work position. See **Adjusting The Lights**.
3. Turn the winch handle (A, Figure 20) clockwise (B) until the tower is fully raised. Do not overturn the handle.

Lowering the Light Tower - Winch

1. Shut down the engine. See **Operating The Engine**. Wait 10 minutes for the lights to cool.
2. Turn the winch handle counterclockwise (C) until the tower is fully lowered. Do not overturn the handle.

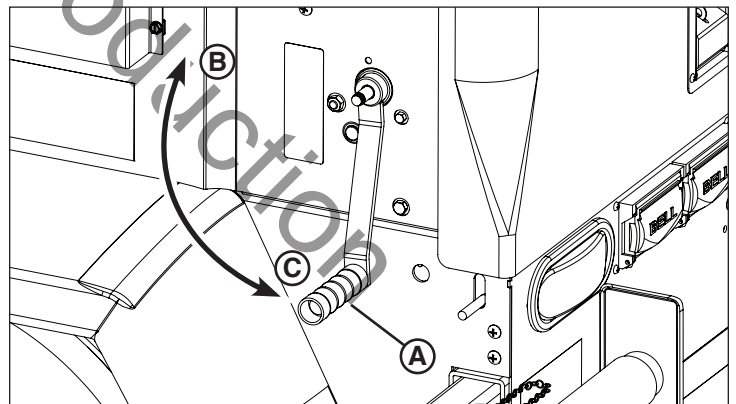

Figure 20

Raising the Light Tower - Electric (Optional)

1. Shut down the engine. See **Operating The Engine**. Wait 10 minutes for the lights to cool.
2. Before raising the light tower, adjust the tower lights to the desired work position. See **Adjusting The Lights**.
3. Move the tower raise switch (A, Figure 21, on the right side of the ignition switch) up until the tower is fully raised.

NOTE: The ignition switch must be turned to the RUN position (B, Figure 21) to operate the tower raise switch.

Lowering the Light Tower - Electric (Optional)

1. Shut down the engine. See **Operating The Engine**. Wait 10 minutes for the lights to cool.
2. Move the tower raise switch down until the tower is fully lowered.

NOTE: The ignition switch must be turned to the RUN position (B, Figure 21) to operate the tower raise switch.

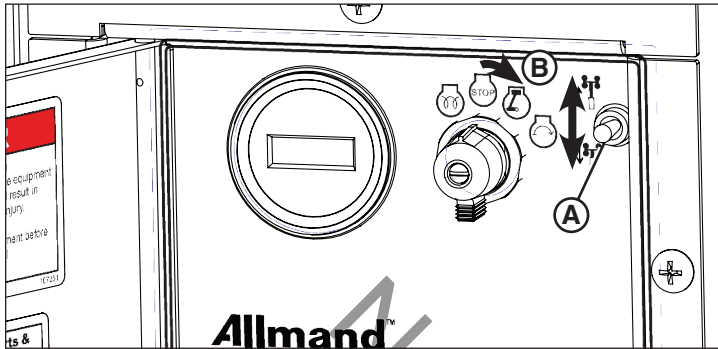

Figure 21

Operating The Tower Lights



WARNING

- Looking at illuminated light fixtures could result in serious injury. Never look directly at illuminated light fixtures.

Turning The Lights On

The tower lights will automatically turn on after the engine is started. (There is a 20-second delay built into the electrical system.) However, the main light breaker or individual light switches may be set to OFF.

- Turn on the main light breaker (A, Figure 22) (if set to OFF).
- Turn on individual light switches (B, Figure 22) (1 - 4, if set to OFF).

The breaker / switches may also be used if manual and individual light control is desired.

Turning The Lights Off

Shut down the engine to turn the lights off. See **Operating The Engine**. (The lights can also be turned off manually. See **Turning The Lights On**.)

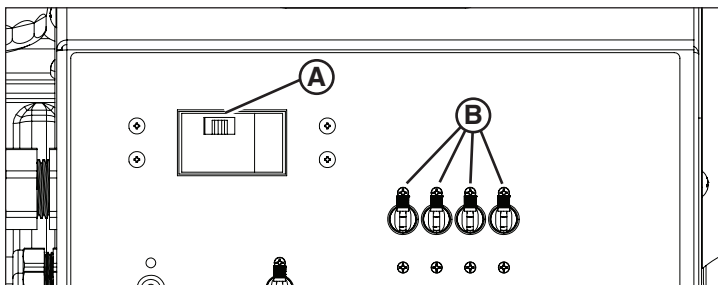

Figure 22

Auxiliary AC Outlets

The control panel is equipped with a standard GFCI outlet (A, Figure 23) and Twistlock outlet (B). (Outlets are covered.)

Power is supplied to the outlet(s) only when the engine is running and the main circuit breaker (C, Figure 23) is in the ON position.

NOTE: The electrical system is designed with a 20-second delay after the engine starts before the lights and auxiliary AC outlet(s) will operate.

Each outlet is protected by a dedicated circuit breaker: 20 amp for GFCI (D, Figure 23), 30 amp for Twistlock (E).

If a breaker trips

1. Disconnect the load from the outlet.
2. Shut down the engine.
3. Wait 10 minutes for the generator to cool down.
4. Correct the load problem.
5. Start the engine.
6. Reset the breaker.

NOTE: Be sure to also check the GFCI breaker on the GFCI outlet, and reset if necessary.

7. Reconnect the load.
8. If the problem persists, see **Troubleshooting**.

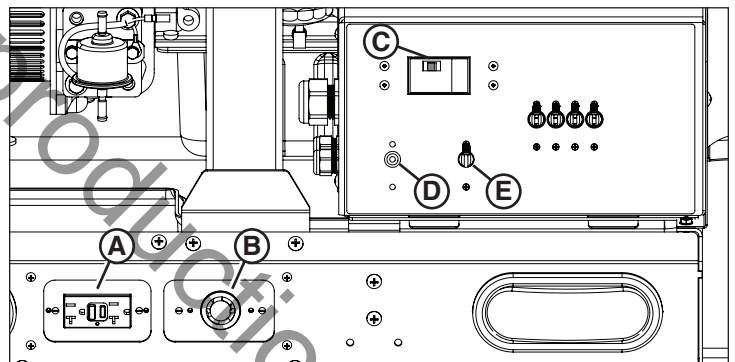

Figure 23

Unit Shutdown

Once lighting operations are complete at the work site, perform unit shutdown:

1. Shut down the engine. See **Operating The Engine**.
2. Wait 10 minutes for the lights to cool.
3. Lower the light tower. See **Raising And Lowering The Light Tower**.
4. Rotate the light tower to the transport position. See **Adjusting The Lights**.
5. Adjust the light fixtures to the transport position. See **Adjusting The Lights**.
6. Make sure the engine compartment cover is closed and latched.

7. Make sure the fuel door, radiator door and engine panel door are closed and secured.
8. Retract the outriggers. See **Leveling And Stabilizing The Light Tower Trailer**.

The unit is now ready for transport. See **Transporting**.



WARNING

- Do not remove the wheel chocks from the front and back of the wheels until the light tower trailer is ready to be transported. Doing so could result in death or serious injury.

Maintenance

Before performing any maintenance procedures, read **Safety**.

Proper maintenance and care of the equipment is a must for safe and reliable operation. Use the following maintenance and care guidelines in addition to those scheduled by your shop equipment maintenance schedule.

Where equipment is operated under severe conditions (very dusty, extreme heat or cold, etc.), affected items should be serviced more frequently.



WARNING

Operating or towing a machine with worn, damaged or missing parts can result in death or serious injury. Always replace worn, damaged or missing parts promptly. Do not operate or tow this machine until all worn, damaged or missing parts have been replaced, and proper operation of the machine has been verified.

Engine

Refer to the Engine Operator's Manual for all scheduled engine maintenance procedures (including oil, coolant, filters, etc.).

Engine Oil Drain

The unit is equipped with a remote engine oil drain (A, Figure 24), located on the right side of the light tower trailer toward the rear. To drain the engine oil:

1. Place an approved container beneath the oil drain.
2. Remove the oil drain plug.
3. Open the oil drain valve, located to the right of the engine oil pan (B, Figure 24, inset).
4. Allow the engine oil to drain completely into the approved container. Be sure to dispose of used engine oil according to local, state, province and/or federal rules.
5. Close the oil drain valve.
6. Replace the oil drain plug, tightening securely.

7. Add oil to the engine. Refer to the Engine Operator's Manual.

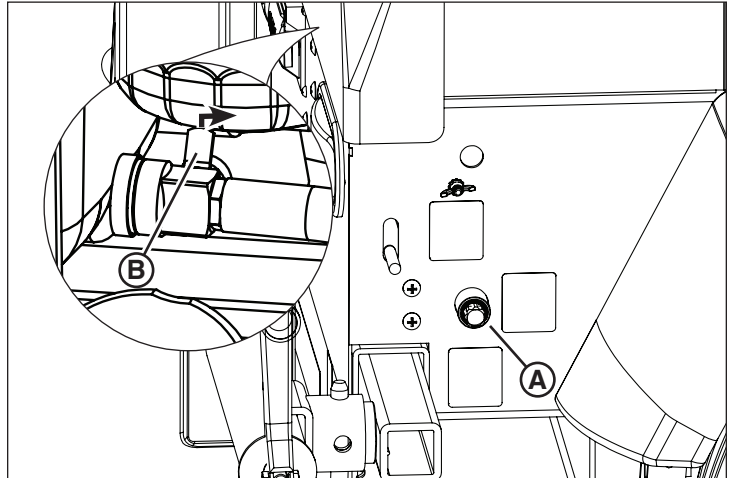

Figure 24

Electrical System

Generator

Refer to the Generator Operator's Manual for all scheduled generator maintenance procedures.

Ballast Panels

The ballast panels are located in the engine compartment toward the front of the light tower trailer. Service or replacement of ballast and capacitors should be performed by an authorized dealer only.



DANGER



Electrocution Hazard

- Ballast and capacitors are capable of discharging high voltage, which will result in death or serious injury. Service or replacement should be performed by an authorized dealer only.

Light Tower And Lamps

Changing Lamps



WARNING



Burn Hazard

- The light fixtures become extremely hot during use.
- Always use caution and heat-resistant glove when handling the lights or allow the lights to sufficiently cool down before handling.

1. Turn off the lights and shut down the engine.
2. Allow 20 minutes for the lights to cool.
3. Lower the light tower.

4. Loosen the lens channel screws (E, Figure 25) to allow the removal of the lens channel (F).
5. Remove the silicone gasket (G, Figure 25) and lens (H).
6. Remove the support clip screws (A, Figure 25) and support clip (B).
7. Carefully remove the old lamp (C, Figure 25), and install the correct replacement lamp. See **Specifications**.
8. Clean the reflector (D, Figure 25) and lens.
9. Install the support clip and screws.
10. Install the silicone gasket and lens. Replace if worn or damaged.
11. Install the lens channel and screws.
12. Test the new lamp to ensure proper operation.

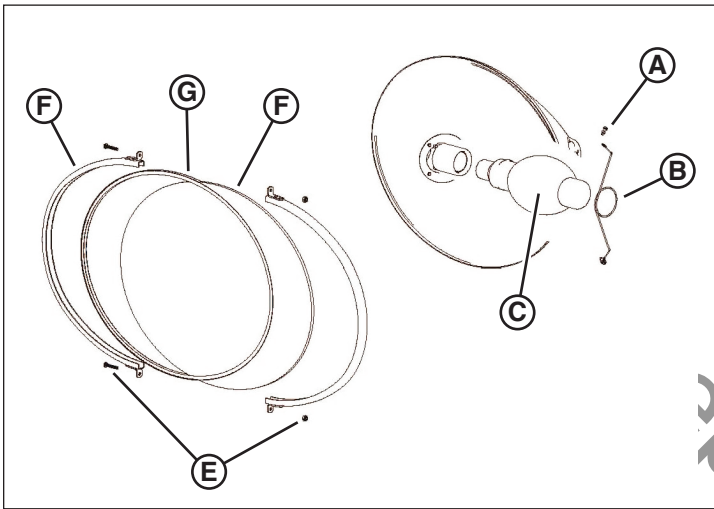

Figure 25

Trailer Frame

1. Check the trailer coupler for proper operation. Check to be sure the hardware is securely tightened. Inspect the trailer coupler for wear, damage or corrosion. Repair or replace as needed.
2. Inspect the safety chains for wear, damage or corrosion. Replace as needed.
3. Inspect the tongue jack for proper operation, and for wear, damage or corrosion. Repair or replace as needed.
4. Inspect the trailer tongue for proper operation, and for wear, damage or corrosion. Check to be sure the hardware is securely tightened. Repair or replace as needed.
5. Inspect the axle, springs and undercarriage for wear, damage or corrosion. Repair or replace as needed.
6. Inspect the outrigger bars, stabilizer jacks and locking pins for proper operation, and for wear, damage or corrosion. Replace as needed.

Trailer Wheels and Tires



WARNING

Towing Hazard

Towing the light tower trailer with damaged tires, rims or lug nuts could result in death or serious injury. Repair or replace damaged tires, rims or lug nuts before towing the light tower trailer.

1. Check the tires for any cracks, cuts or damage. Repair or replace as needed.
2. Check the tire pressure of the trailer tires when cold. See **Specifications**.
3. Check the wheel rims for any cracks or damage. Repair or replace as needed.
4. Make sure all the lug nuts are in place and properly tightened. Correct torque for the lug nuts is 90 lb-ft (122 Nm).

Servicing The Axle

The axle under the light tower trailer will require periodic maintenance and service. Such things as wheel bearing adjustment and repacking will be required to maintain the axle. For information on the maintenance schedule and servicing the axle, see the axle owner's manual.

Trailer Lighting



WARNING

Towing Hazard

- Towing the light tower trailer with inoperable trailer lights could result in death or serious injury. Repair or replace inoperable trailer lights.

Trailer lights are a safety feature, and are required by law. Keep the trailer lights in proper working order.

- Check the trailer lights and wiring for damage or wear. Repair or replace as needed.
- Check to be sure the wiring harness is secured to the trailer and does not hang down to the ground.
- Check the trailer light housing assemblies for damage or leaks. Use silicone or rubber sealant to seal the lens or harness, as needed, or replace the housing assembly. Electrical grease will help protect the sockets and prevent corrosion.
- When replacing bulbs, be sure to use the correct replacement bulb. A small amount of electrical grease in the sockets will prevent corrosion.

For trailer wiring schematic information, refer to the separate Wire Schematic Manual.

Maintaining the Battery



WARNING



Batteries give off explosive gases during recharging. Sparks can cause explosions, resulting in death or serious injury.

Batteries contain acid, which is extremely caustic. Contact with battery contents will cause severe chemical burns.

Batteries present a risk of electric shock and high short circuit current.

- Always disconnect the negative (-) battery cable before servicing equipment.
- DO NOT dispose of battery in a fire. Recycle battery.
- DO NOT allow any open flame, spark, heat, or lit cigarette during and for several minutes after charging a battery.
- DO NOT open or mutilate battery.
- DO NOT charge a frozen battery. Always slowly warm the battery to room temperature before charging.
- Wear protective gloves, rubber apron, rubber boots and rubber gloves.
- Remove watches, rings, or other metal objects.
- Use tools having insulated handles.

Removing and Installing the Battery

To remove the battery

1. Unlatch and open the engine compartment cover.
2. Disconnect the black negative (-) cable (**A**, Figure 26) from the negative (-) battery terminal, and secure away from the battery.



WARNING



Explosion Hazard

- Failure to remove the black negative (-) battery cable(s) first could cause sparks and/or an explosion resulting in death or serious injury. Always remove the black negative (-) battery cable(s) first.

3. Disconnect the red positive (+) battery cable (**B**, Figure 26) from the positive (+) battery terminal, and secure away from the battery.
4. Loosen the hardware securing the battery hold-down (**C**, Figure 26), and remove the hold-down.
5. Carefully remove the battery, and place in a well-ventilated area on a level surface.

To install the battery:

1. Carefully place the battery in the engine compartment with the battery terminals toward the front of the unit.

2. Install the battery hold-down on top of the battery. Tighten the hardware securely.
3. Connect the red positive (+) battery cable(s) to the positive (+) battery terminal.
4. Connect the black negative (-) battery cable(s) to the negative (-) battery terminal.



WARNING



Explosion Hazard

- Failure to install the black negative (-) battery cable(s) last could cause sparks and/or an explosion resulting in death or serious injury. Always install the black negative (-) battery cable(s) last.

5. Replace the terminal covers over the battery terminals.
6. Close and latch the engine compartment cover.

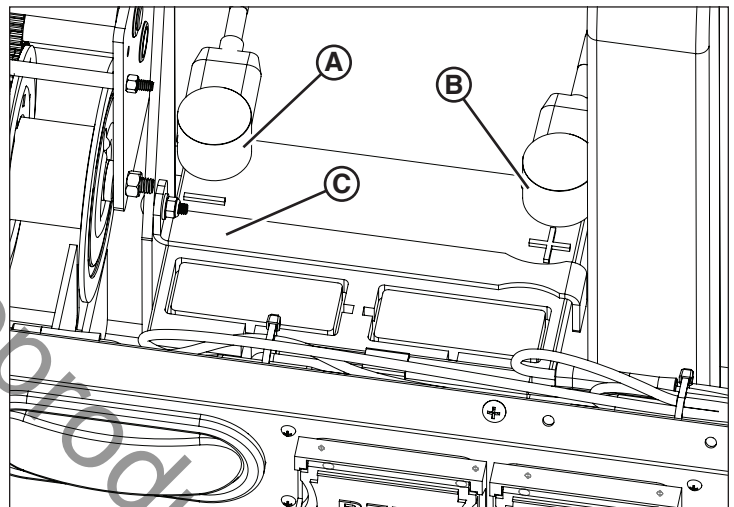

Figure 26

Cleaning



WARNING



Entanglement Hazard

- Failure to shut down the engine before cleaning the unit could result in death or serious injury. Always shut down the engine before cleaning the unit.



WARNING



Burn Hazard

- Shut down the engine and lights and allow ample time for components to cool before cleaning the unit. Failure to do so could result in serious burns.

NOTICE

Use caution when using compressed air or water / steam pressure washers. Do not pressure-clean electrical components, as this may cause damage.

Keeping the light tower clean is important to ensure proper operation. Dirt and dust buildup acts as an insulator and may cause the engine, generator and light assemblies to operate at excessively high temperatures.

Use the following as cleaning guidelines:

- Clean the light tower trailer to remove all dust, dirt or other foreign material.
- Clean the light tower and light fixture assemblies with a damp cloth or sponge.
- Clean all electrical wiring and components by hand using non-corrosive cleaner.
- Clean the inside of the engine compartment.
- Clean any oil or liquid spills inside the engine compartment.
- Empty the fluid containment tray. See **Draining The Fluid Containment Tray**.

Draining the Fluid Containment Tray

The light tower trailer is equipped with an optional fluid containment tray designed to catch fuel, oil or coolant spills. The tray should be drained periodically, and before storing the unit.

To drain the tray

1. Position a suitable container beneath the fluid containment drain (**A**, Figure 27), located under the right side of the light tower trailer behind the front forklift pocket.
2. Remove the drain plug.
3. Allow the tray to drain completely into the container.

NOTE: Lowering the trailer tongue slightly using the tongue jack will assist in draining the containment tray.

4. Reinstall the drain plug, tightening securely.
5. Dispose of the fluid in accordance with government guidelines.

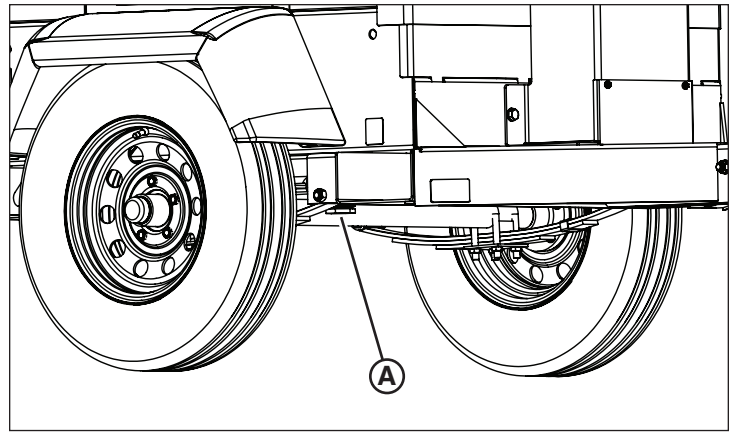

Figure 27

Model And Serial Numbers

Model and serial number information is required for product support and repair parts. Following are the model and serial number locations of the primary components.

Trailer

The serial number plate for the light tower trailer is located on the left side of the unit above the front forklift pocket (**A**, Figure 28).

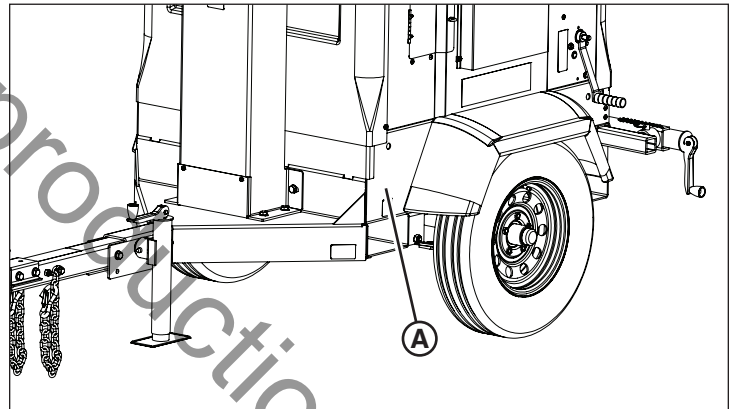

Figure 28

Generator

The generator has a serial number plate (A, Figure 29) attached to the top of the housing.

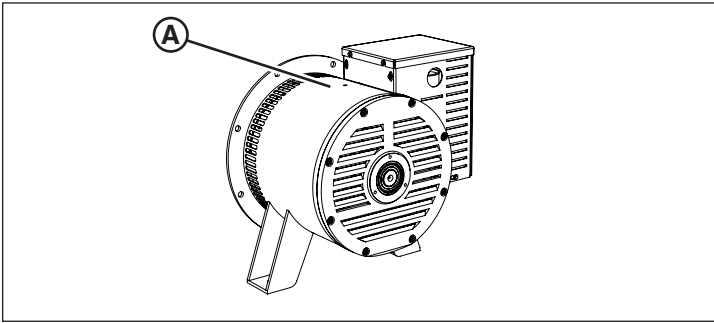

Figure 29

Engine

Kubota: The engine has a serial number plate (A, Figure 30) attached on the upper right side of the engine block above the fuel injection pump.

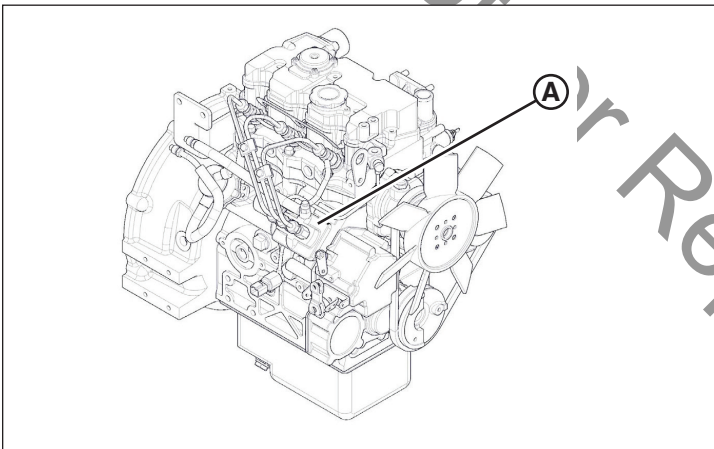

Figure 30

Mitsubishi: The engine has a serial number plate (A, Figure 31) attached to the top of the engine.

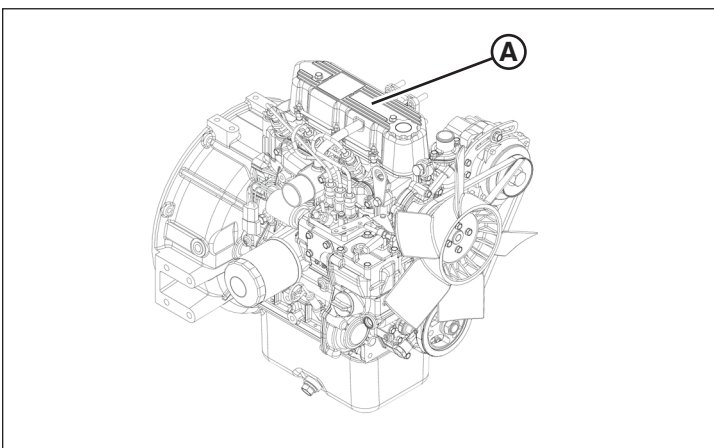

Figure 31

Specifications

NOTE: Refer to the Engine or Generator Operator's Manual for specific engine or generator specifications.

Overall Dimensions

Height - light tower lowered	10 ft (3,05m)
Height - light tower raised	25 ft 6 in (7,77m)
Length	14 ft 7 in (4,45m)
Width (outriggers retracted)	4 ft 3 in (1,3m)
Width (outriggers extended)	8 ft 10 in (2,69m)
Dry Weight	1710 lbs (776 kg)

Trailer

Hitch Coupler	2 inch (50,8mm) ball hitch / 3 inch (75mm) pintle ring / 2-5/16 inch (58,7mm) ball hitch (optional)
Max Road Speed (paved road)	65 mph (105 km/h)
Max Off-Road Speed	20 mph (32 km/h)
Number of Axles	1
Axle Rating (GAWR)	2500 lbs (1134 kg)
Tire Size and Rating	ST175/80D13 Load Range 'C'
Rims	13 x 4.5 JJ
Cold Tire Inflation Pressure	36 psi (248 kPa)
Trailer Light Connector	4-Pin plug / 7-pin (optional)
Lifting Eye	1
Tie-Down Points	4
Forklift Pockets	2 each side
Number of Outrigger Stabilizers	2
Tongue Jack	Standard

Light Tower

Sections	5
Max Continuous Wind Load	50 mph (80 km/h) (with jack and outriggers deployed on firm, level surface)
Light Bar Rotation	359°

Generator

7.0 kW (Kubota)	Standard
6.0 kW (Mitsubishi)	Standard
120VAC GFCI Outlet	Standard
125/250VAC Twistlock	Standard

Tower Lights

SHO - HD 1250W Metal Halide (lumen rating: 150,000)	Standard 60Hz
---	---------------

SHO - HD 1250W Metal Halide	Warm-Up Time: 2-4 minutes Re-Start Time: 10-15 minutes
Light Fixtures	Standard (sealed for all weather use)
Light Fixture Weight	15 lbs (6,75 kg)

Engine - Kubota

Model	Kubota D1005
Type	Water Cooled 3-Cylinder Diesel
Displacement	61 cu in (1001cc)
Power @1800rpm	11.7hp (8,7kW)
NOTE: Horsepower ratings are established in accordance with Society of Automotive Engineers Small Engine Test Code - J1349 GROSS	
Fuel System	Indirect Injected Diesel
Electrical System	12VDC Negative Ground
Battery Type	Group 24
Battery Rating	525 CCA @ 0°F (-18°C)
Number of Batteries	1
Weight	205 lbs (93kg)
Oil Capacity	5.4 qt (5,1 L)
Lubrication	Forced Lubrication By Pump
Oil Filtration	Cartridge Type
Cooling System	Pressurized radiator forced circulation with water pump
Low Oil Pressure Shutdown	Standard all engines
High Engine Temperature Shutdown	Standard all engines
Glow Plug Cold Start Assist	Standard all engines
Fuel	In North America, diesel fuels that meet ASTM D975 for Ultra Low Sulfur Diesel (ULSD) are required to be used. ULSD has a maximum sulfur content of 15 parts per million (PPM) or 15 mg/kg. Diesel fuel may be No. 1-D or No. 2-D.
Engine Oil	Use a high quality engine oil of API (American Petroleum Institute) service class CG-4/CH-4/CI-4. Refer to the Engine Operator's Manual for more detailed engine oil requirements.
Fuel Tank	45 gal (170 L)
Cooling System	5.5 qt (5,2 L)
Overflow Reservoir	1.1 qt (1,0 L)



Engine - Mitsubishi

Model	Mitsubishi L3E
Type	Water Cooled 3-Cylinder Diesel
Displacement	58 cu in (952cc)
Power @1800rpm	11.3hp (8,4kW)
NOTE: Horsepower ratings are established in accordance with Society of Automotive Engineers Small Engine Test Code - J1349 GROSS	
Fuel System	Indirect Injected Diesel
Electrical System	12VDC Negative Ground
Battery Type	Group 24
Battery Rating	525 CCA @ 0°F (-18°C)
Number of Batteries	1
Weight	194 lbs (88kg)
Oil Capacity	5.0 qt (4,7 L)
Lubrication	Forced Lubrication By Pump
Oil Filtration	Cartridge Type
Cooling System	Pressurized radiator forced circulation with water pump
Low Oil Pressure Shutdown	Standard all engines
High Engine Temperature Shutdown	Standard all engines
Glow Plug Cold Start Assist	Standard all engines
Fuel	In North America, diesel fuels that meet ASTM D975 for Ultra Low Sulfur Diesel (ULSD) are required to be used. ULSD has a maximum sulfur content of 15 parts per million (PPM) or 15 mg/kg. Diesel fuel may be No. 1-D or No. 2-D.
Engine Oil	Use a high quality engine oil of API (American Petroleum Institute) service class CG-4/CH-4/CI-4. Refer to the Engine Operator's Manual for more detailed engine oil requirements.
Fuel Tank	45 gal (170 L)
Cooling System	5.5 qt (5,2 L)
Overflow Reservoir	1.1 qt (1,0 L)

Troubleshooting



Before performing any troubleshooting procedures, read the following safety messages, and read **Safety**.

For engine and generator troubleshooting, refer to the Engine Operator's Manual and Generator Operator's Manual, or contact your authorized dealer.

DANGER



Electrocution Hazard

- High voltage is present when engine is running. Never attempt to service electrical components while engine is running.

DANGER

Electrocution Hazard

- Ballast and capacitors are capable of discharging high voltage, which will result in death or serious injury. Service or replacement should be performed by an authorized dealer only.

WARNING

Burn Hazard

- The light fixtures become extremely hot during use.
- Always use caution and heat-resistant glove when handling the lights or allow the lights to sufficiently cool down before handling.

Always follow the electrical component manufacturer specifications for voltage and test procedures.

Troubleshooting Chart

Problem	Possible Cause
No light (one or more lights)	1. Circuit breakers in the circuit breaker box are not turned on or have tripped.
	2. Lamps are not allowed time to cool after last being lit. You must allow 15 minutes between the time the lights are shut off and the time they are restarted.
	3. The lamp or lamps are burned out or broken.
	4. One or more of the lamps are not screwed in securely.
	5. Plug and socket at light bar not securely pushed together and locked.
	6. The temperature of the ballast is below -29°C (-20°F). The efficiency of the capacitors in the ballast is not enough to ignite the lamps. For operations where the temperature of the ballast falls below -29°C (-20°F), some means of warming the ballast must be used.
	7. Low electrical system voltage.
	8. A loose connection in the back of the lamp socket in the lamp holder.
	9. A circuit breaker or breakers are defective.
	10. A loose connection on the terminal board.
	11. The engine and generator are not running up to speed. (1800 RPM)
	12. A wrong style replacement lamp (requiring a different ballast) has been installed.
	13. Too much power is being drawn from the auxiliary outlets.
	14. Capacitor or transformer has failed.
	15. Corrosion has occurred on the lamp bases.

Not for Reproduction

Not for Reproduction

Not for Reproduction

Not for Reproduction