

Allmand™

Brighter. Warmer. Safer.

Portable
Industrial
Heaters

Portable
Light Towers

Portable
Light Stands

Solar Flashing
Arrow Boards



(en) Set-Up Instruction / Operator's Manual
Balloon Light

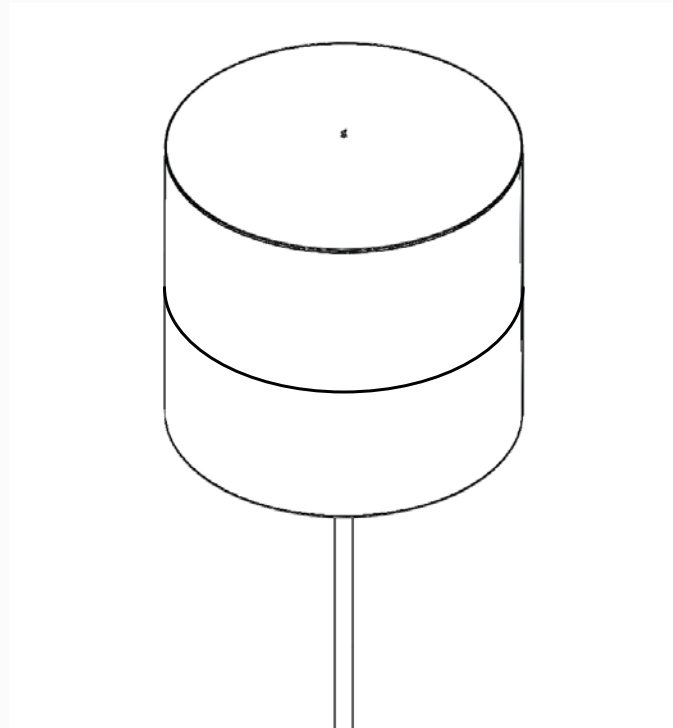

Copyright © 2016 Allmand Bros., Inc.
Holdrege, NE, USA. All rights reserved.

Part No.: 107339
Revision: B

LIGHT TOWER APP



Reliability, Performance, and Integrity Since 1938

www.allmand.com

Record Important Information

Recording the equipment information will help when placing an order for replacement parts and/or decals.

Company Equipment No: _____

Unit model No: _____

Unit Vin: _____

Engine Model No: _____ Serial No: _____

Generator Model No: _____ Serial No: _____

Accessories: _____

Manual Contents:

Introduction	2
Safety.....	2
Kit Contents	5
Balloon Light Installation	6
Operation	10
Transporting.....	11
Maintenance	12
Troubleshooting	13
Specifications.....	13

Introduction

About This Manual

TAKE TIME TO READ THIS MANUAL THOROUGHLY

This instruction manual provides necessary instructions for the Balloon Light.

The information found in this manual is in effect at the time of printing. Allmand Bros Inc. may change contents without notice and without incurring obligation.

Any reference in this manual to left or right shall be determined by looking at the trailer from the rear.

If you are uncertain about any of the information in the manual, contact Allmand service department at 1-800-562-1373, or contact us through the Allmand website, www.allmand.com.

Save these original instructions for future reference.



Products Covered by This Manual

The following products are covered by this manual:

Balloon Light

Safety

Safety Definitions

Safety statements are one of the primary ways to call your attention to potential hazards. Follow the precautions listed throughout the manual before operation, during operation and during periodic maintenance procedures for your safety, the safety of others and to protect the performance of equipment. Keep the decals from becoming dirty or torn and replace them if they are lost or damaged. Also, if a part needs to be replaced that has a decal attached to it, make sure to order the new part and decal at the same time.



Indicates a potential personal injury hazard.



DANGER

Indicates a hazardous situation which, if not avoided, **will** result in death or serious injury.



WARNING

Indicates a hazardous situation which, if not avoided, **could** result in death or serious injury.



CAUTION

Indicates a hazardous situation which, if not avoided, **could** result in minor or moderate injury.

NOTICE

Indicates information considered important, but not hazard-related.

Safety Precautions

The following section contains general safety precautions and guidelines that must be followed to reduce risk to personal safety. Special safety precautions are listed in specific procedures. Read and understand all of the safety precautions before operating or performing repairs or maintenance.



DANGER



Electrocution Hazard

Electrocution hazard will result in death or serious injury.

- Always check overhead wires and obstructions before raising or lowering the light tower.
- Always follow the rules or instructions for your work site and state, province and national electric code for maintaining a safe distance from overhead wires.
- High voltage is present when engine is running. Never attempt to service electrical components while engine is running.
- Do not operate the light tower if the insulation on the electrical cord or other electrical wiring is cut or worn or if bare wires are exposed. Repair or replace damaged wiring before starting the engine.



WARNING



Explosion Hazard

Explosion hazard could result in death or serious injury.

- While the engine is running or the battery is charging, hydrogen gas is being produced and can be easily ignited. Keep the area around the battery well ventilated and keep sparks, open flame and any other form of ignition out of the area.
- Always disconnect the negative (-) battery cable before servicing equipment.
- Only use the starting procedure as described in the Engine Operator's Manual to start the engine.
- Never charge a frozen battery. Always slowly warm the battery to room temperature before charging.



WARNING

Fall Hazard

Fall hazard could result in death or serious injury.

- Never carry riders on the equipment.



WARNING



Fire And Explosion Hazard

Fire and Explosion hazard could result in death or serious injury.

- Diesel fuel is flammable and explosive under certain conditions.
- Never use a shop rag to catch fuel.
- Wipe up all spills immediately.
- Never refuel with the engine running.
- Store any containers containing fuel in a well ventilated area, away from any combustibles or sources of ignition.



WARNING

Exposure Hazard

Exposure hazard could result in death or serious injury.

- Always wear personal protective equipment, including appropriate clothing, gloves, work shoes, and eye and hearing protection, as required by the task at hand.



WARNING

Rollover Hazard

Rollover hazard could result in death or serious injury.

- Do not raise, lower or use light tower unless all outriggers and jacks are positioned on firm ground.
- Never move or reposition the light tower while the light tower is extended in the vertical position.



WARNING



Exhaust Hazard

Exhaust hazard could result in death or serious injury.

- All internal combustion engines create carbon monoxide, a poisonous gas that could kill you in minutes.
- Operate this product only outdoors far away from windows, doors and vents to reduce the risk of carbon monoxide gas from accumulating and potentially being drawn towards occupied spaces.
- Always ensure that all connections are tightened to specifications after repair is made to the exhaust system.



WARNING

Alcohol And Drug Hazard

Alcohol and drug use while operating this product could result in death or serious injury.

- Never operate the light tower while under the influence of alcohol or drugs, or when ill.



WARNING

Coolant Hazard

Coolant hazard could result in death or serious injury.

- Wear eye protection and rubber gloves when handling engine coolant. If contact with the eyes or skin should occur, flush eyes and wash immediately with clean water.



WARNING

Entanglement / Sever Hazard

Entanglement / Sever hazard could result in death or serious injury.

- Always stop the engine before beginning service.
- Verify that all guards and covers are attached properly to the equipment before starting the engine. Do not start the engine if any guards or covers are not properly installed on the equipment.
- Attach a "Do Not Operate" tag near the key switch while performing maintenance on the equipment.



WARNING

Burn Hazard

Burn hazard could result in death or serious injury.

- Light fixtures and some of the engine surfaces become very hot during operation and shortly after shutdown.
- Keep hands and other body parts away from hot engine surfaces.
- Handle hot components, such as light fixtures, with heat resistant gloves.



WARNING

Piercing Hazard

Piercing hazard could result in death or serious injury.

- Avoid skin contact with high pressure hydraulic fluid or diesel fuel spray caused by a hydraulic or fuel system leak such as a broken hydraulic hose or fuel injection line. High pressure hydraulic fluid or fuel can penetrate your skin and result in serious injury. If you are exposed to high pressure hydraulic fluid or fuel spray, obtain prompt medical treatment.
- Never check for a hydraulic fluid or fuel leak with your hands. Always use a piece of wood or cardboard.



CAUTION

Slip Hazard

Slip hazard could result in minor or moderate injury.

- Immediately clean up any spilled liquid on the shop floor.
- Clean up accumulated dirt and debris on the shop floor at the end of each shift.

NOTICE

The statements that follow have NOTICE level issues. Damage to equipment or property can result if not followed.

- Any part which is found defective as a result of inspection or any part whose measured value does not satisfy the standard or limit **MUST** be replaced.
- Always use tools appropriate for the task at hand and use the correct size tool for loosening or tightening equipment parts.
- Always tighten components to the specified torque. Loose parts can cause equipment damage or cause it to operate improperly.
- Follow the guidelines of the Environmental Protection Agency (EPA), Environment Canada (EC) or other governmental agencies for the proper disposal of hazardous materials such as engine oil, diesel fuel and engine coolant.
- Only use replacement parts specified. Other replacement parts may affect warranty coverage.
- Clean all accumulated dirt and debris away from the body of the equipment and its components before you



WARNING

Flying Object Hazard

Flying object hazard could result in death or serious injury.

- Always wear eye protection when cleaning the equipment with compressed air or high pressure water. Dust, flying debris, compressed air, pressurized water or steam may injure your eyes.



inspect the equipment or perform preventative maintenance procedures or repairs. Operating equipment with accumulated dirt and debris will cause premature wear of equipment components.

- Never dispose of hazardous materials by dumping them into a sewer, on the ground, or into groundwater or waterways.
- Retrieve any tools or parts that may have dropped inside of the equipment to avoid improper equipment operation.
- If any alert indicator illuminates during equipment operation, stop operation immediately. Determine the cause and repair the problem before continuing to operate the equipment.

Safety Decals

Before operating your unit, read and understand the following safety decals. The hazards and instructions provided are for your safety. To avoid personal injury or damage to the unit, understand and follow all the decals.

If any safety or instructional decals become worn or damaged, and cannot be read, order replacement decals from your dealer.

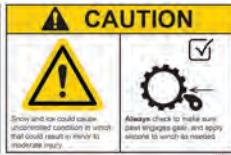
All Models	
<p>DANGER - Shock Hazard. Entering electrical compartment while equipment is running will result in death or serious injury. Always shut down equipment before entering electrical compartment.</p>	
<p>WARNING - Burn Hazard. Handling light fixtures when they are hot could result in death or serious injury. Always keep clear of light fixtures when illuminated or hot.</p>	
Vertical Towers	
<p>WARNING - Crush Hazard. Failure to lock balloon light in upright position before machine operation could result in death or serious injury. Always lock balloon light in upright position before operation.</p>	
<p>CAUTION - Snow and Ice Hazard. Snow and ice could cause uncontrolled condition in winch that could result in minor or moderate injury. Always check to make sure pawl engages gear, and apply silicone to winch as needed.</p>	

Kit Contents

Locate and identify the kit contents. Compare Figures 1 and 2 with the tables following.

NOTE: Kit contents are not to scale.

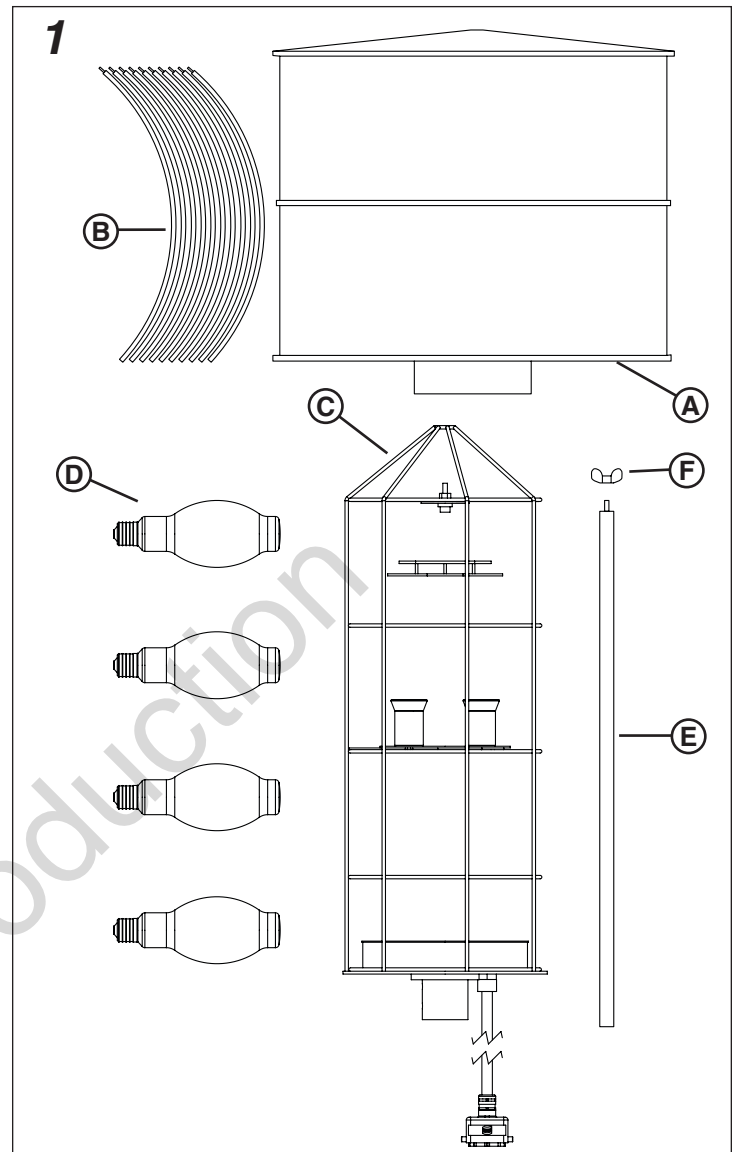

Ref	Description	Qty
All Models		
A	Balloon Shade	1
B	Hoop Rib	12
C	Light Cage	1
D	1250W Bulb	4
E	Extension Rod	1
F	Wing Nut	1

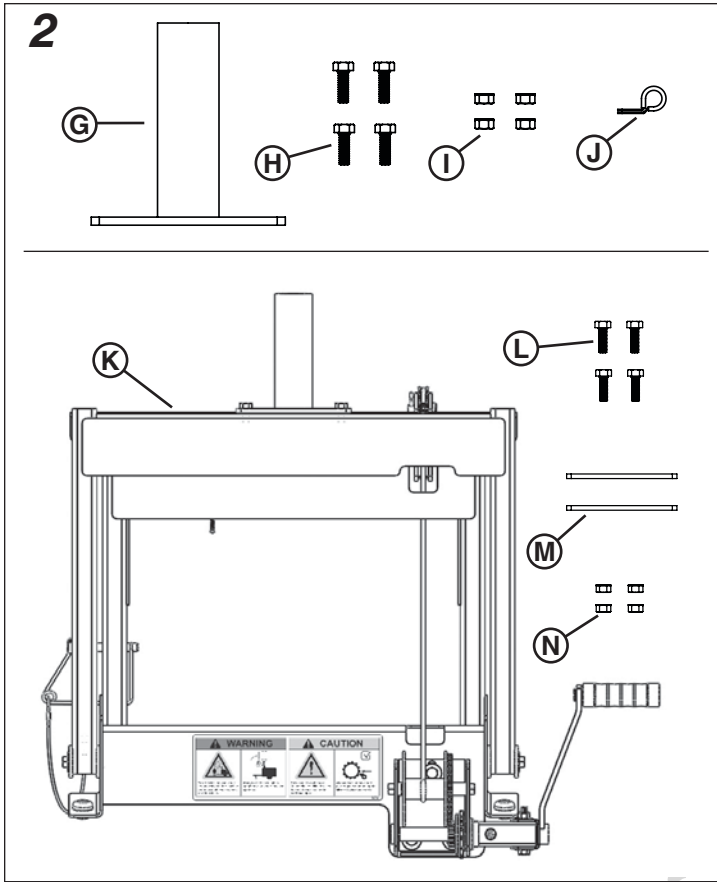

Balloon Light Installation

Before Installation:

1. Lower the light tower to its transport position. Refer to the light tower operator's manual.
2. Shut down the light tower. Disconnect the battery, black negative (-) cable first. If the lights have been in operation, allow ample time for the fixtures to cool. Refer to the light tower operator's manual.



DANGER

Electrocution Hazard

Electrocution hazard could result in death or serious injury.

- Attempting to install the balloon light onto the light tower without first shutting down the unit will result in death or serious injury. Shut down the light tower and disconnect the battery before installing the balloon light.



WARNING

Burn Hazard

Burn hazard could result in death or serious injury.

- Light fixtures and some of the engine surfaces become very hot during operation and shortly after shutdown.
- Keep hands and other body parts away from hot engine surfaces.
- Handle hot components, such as light fixtures, with heat resistant gloves.

Ref	Description	Qty
Laydown Towers		
G	Mounting Bracket	1
H	5/16-18 x 1 Bolt	4
I	5/16-18 KEPS Nut	4
J	Cushion Clamp	1
Vertical Towers		
K	Mounting Assembly	1
L	5/16-18 x 1 Bolt	4
M	Spacer Plate	2
N	5/16-18 KEPS Nut	4
Not Shown		
	Storage Case (for light cage and related components - optional)	1
	Storage Bag (for balloon shade)	1
	Glove	1
	Balloon Shade Repair Kit	1

Laydown Tower Mount Installation:

1. Disconnect the light bar cord from the light tower cord.
2. Support the light bar (if equipped), then remove the hardware (O, Figure 3) securing the light bar to the light tower mast. Remove the light bar.

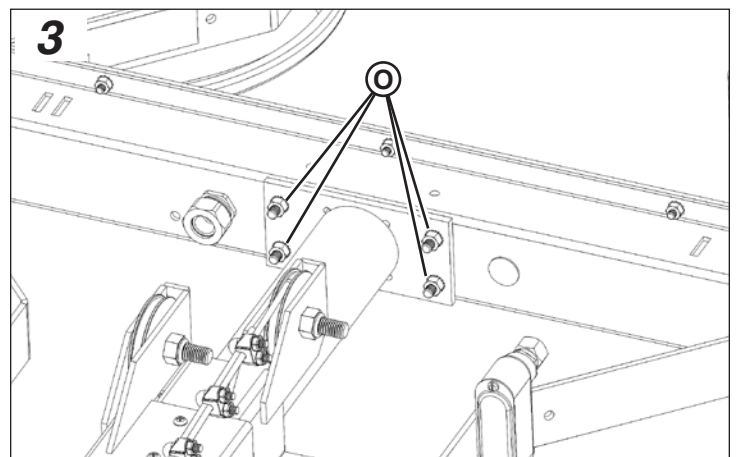

3. a. Install the supplied balloon light mounting bracket (G, Figure 4) to the top of the light tower mast, securing with the four supplied 5/16-18 x 1" hex bolts (H) and keps nuts (I).
- b. Install the supplied cushion clamp (J, Figure 4) to one of the bolt threads before installing the nut. Slip the light tower end of the power cord through the cushion clamp.

3. Remove the bolt (S, Figure 6) on the clamp (T) and remove the tower cord from the clamp.

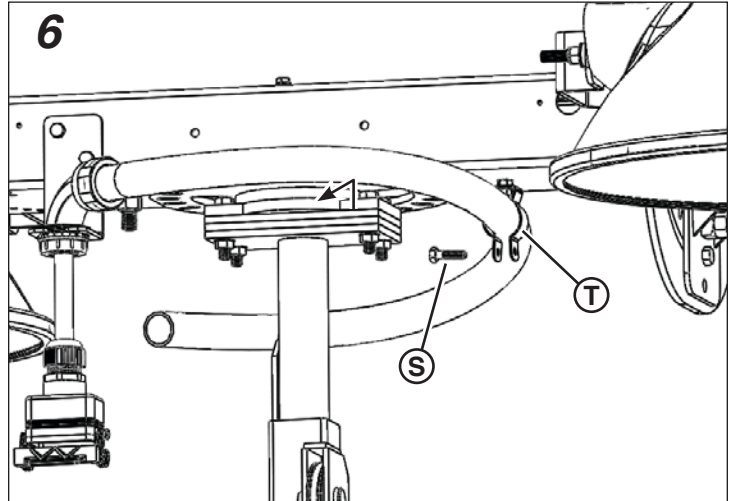
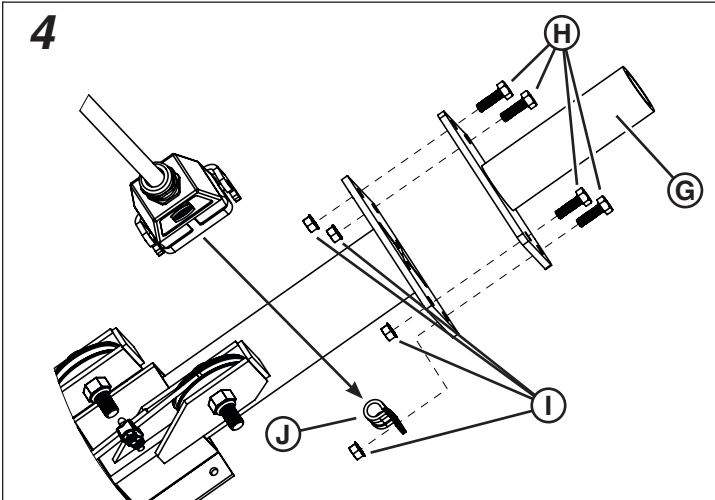

4. Remove the four nuts (U, Figure 7) attaching the light bar to the tower.
5. Using a hoist or safe alternative, remove the light bar.

Vertical Tower Mount Installation:

1. Disconnect the light bar cord from the light tower cord.
2. Loosen the conduit nut (P, Figure 5) and the bushing (Q) from the 90° elbow (R). Lift the elbow up and out of the bracket.

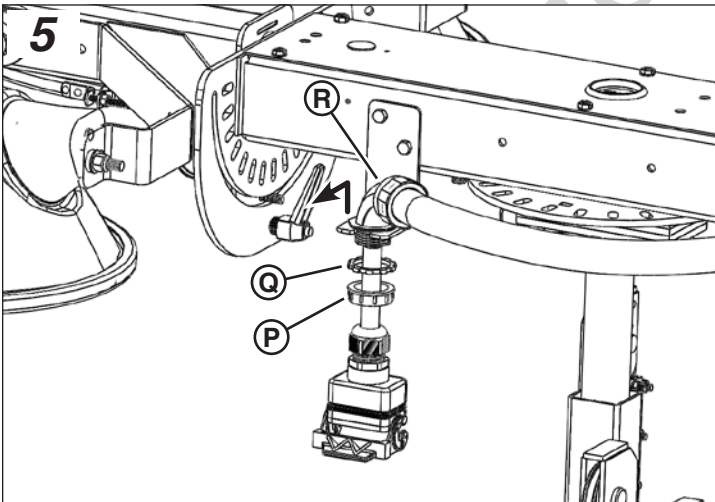
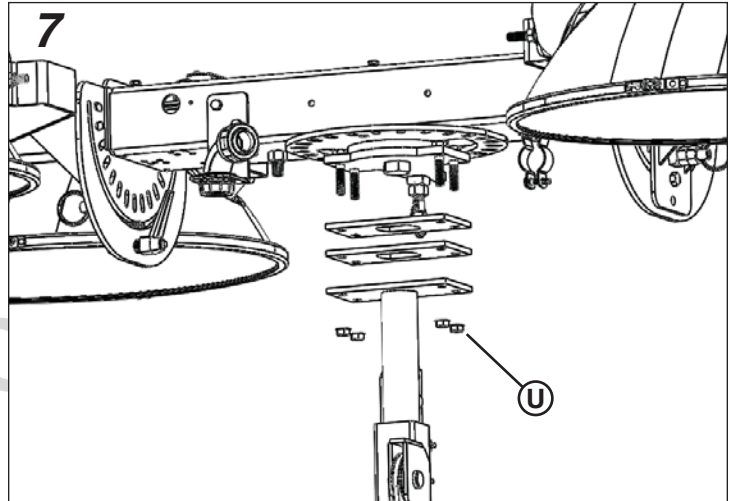

6. Using a hoist or safe alternative, install the mounting assembly (K, Figure 8) onto the light tower using the included bolts (L), spacer plates (M) and keps nuts (N).

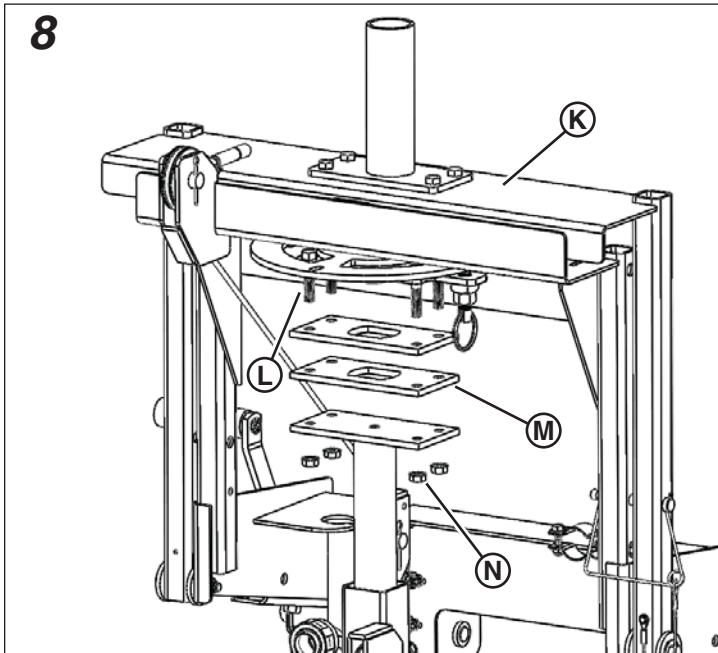

7. Route the end of the tower cord through the bracket shown in Figure 9, with the conduit nut (P) and bushing (Q) on the bottom side of the bracket, and the 90° elbow (R) on the top. Tighten the conduit nut and bushing.

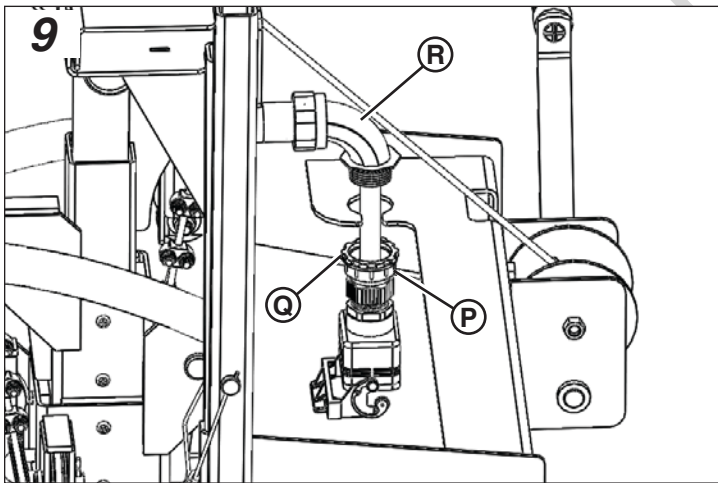

8. Route the tower cord through the clamp (K(1), Figure 10) and secure with the bolt (K(2)).

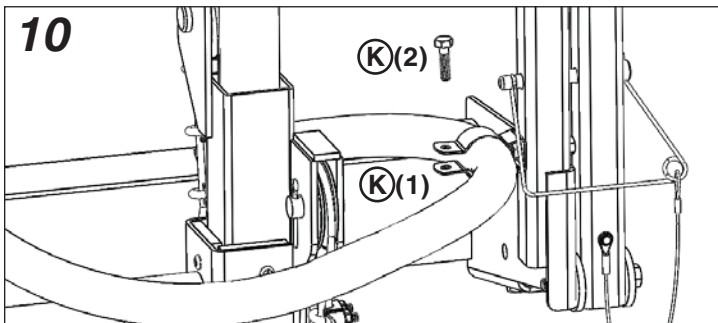

9. The mounting assembly can be lowered for ease of installation and removal of the balloon light.
- Remove the locking pin (K(3), Figure 11).
 - Turn the winch handle (K(4)) to lower the balloon light to a horizontal position.

NOTE: If the mounting bracket does not begin to lower on its own once the winch handle is turned, pull slightly on the bracket to initiate lowering.

- Be sure to raise the mounting bracket to the upright position and secure with the locking pin once the balloon light is installed or removed.



WARNING

Crush Hazard

Crush hazard could result in death or serious injury

- Failure to lock balloon light in upright position before machine operation could result in death or serious injury. Always lock balloon light in upright position before operation.



CAUTION

Snow and Ice Hazard

Snow and ice could cause uncontrolled condition in winch that could result in minor or moderate injury.

- Always check to make sure pawl engages gear, and apply silicone to winch as needed.

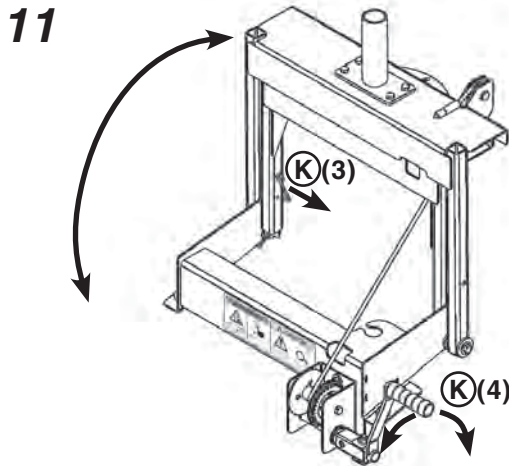

Light Installation:

1. Install the base of the light cage (**C**, Figure 12) over the shaft at the top of the installed mounting bracket (**G** or **K**). Tighten the two securing bolts (**C(1)**) in the base, then tighten the jam nuts (**C(2)**) to lock the bolts in place.

NOTE: Securing bolts and jam nuts may already be installed.

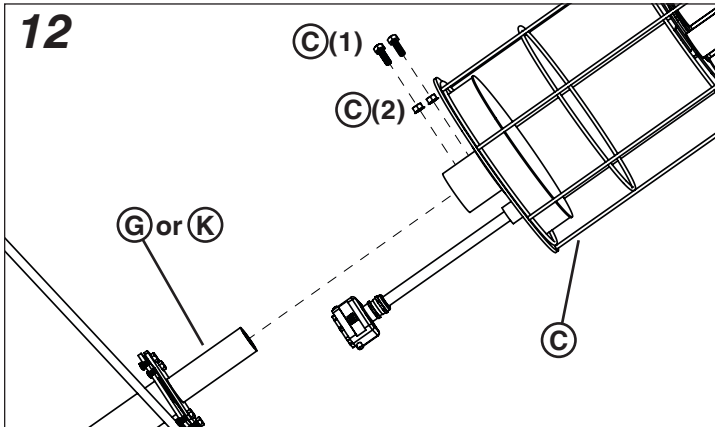

2. Install the tapped end of the extension rod (**E**, Figure 13) through the hole in the top of the light cage (**C**) and onto the threaded bolt inside the upper portion of the light cage. Tighten securely.

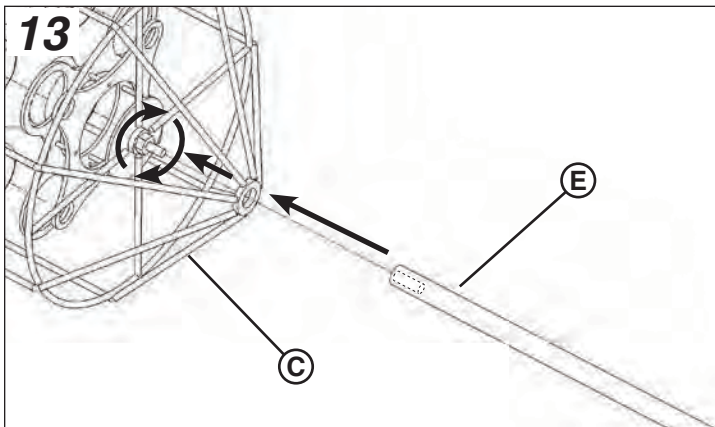

3. Remove the balloon shade (see **A**, Figure 1) from the storage bag (not shown).
4. Slide the pin end of one of the hoop ribs (**B**, Figure 14) through the zippered pocket on top of the balloon shade (**A**). Attach three more hoop ribs to form a circle. (See Figure 15 - shown outside balloon shade for clarity.) Close the zipper to secure the assembled hoop inside the top of the balloon shade.
5. Repeat the previous step for the center and bottom pockets of the balloon shade.

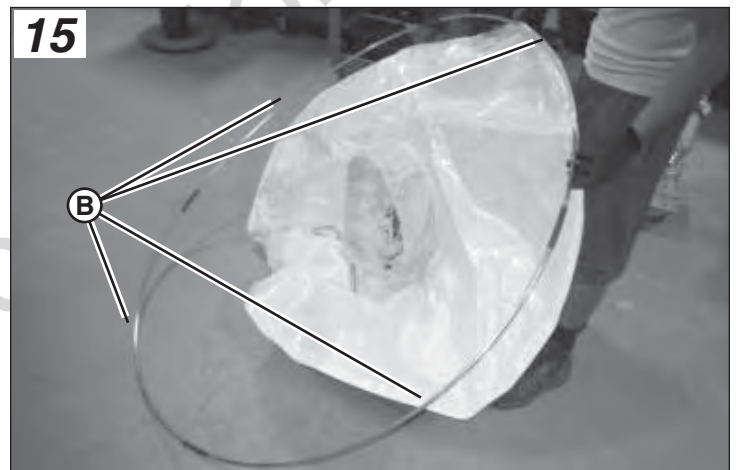
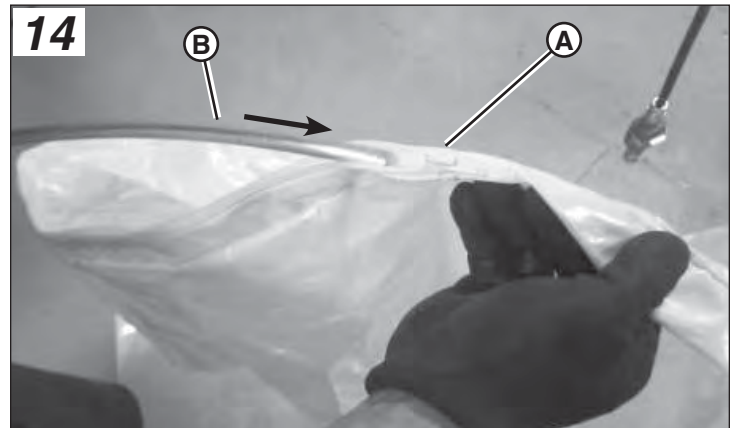

- Position the balloon shade over the extension rod on top of the light cage, with the cuffed opening of the shade facing toward the light cage. See Figure 17. Secure the top of the balloon shade to the extension rod with the supplied wing nut (F, Figure 16). Tighten securely.
- Slide the balloon shade down over the light cage until the cuff extends beyond the cage bottom. See Figures 17 and 18.

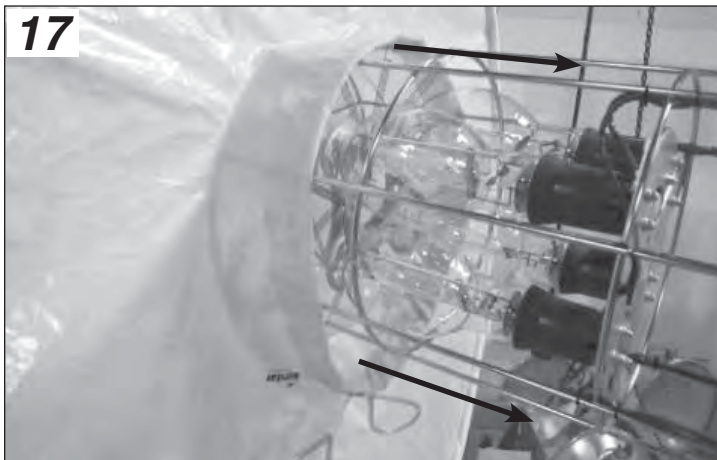
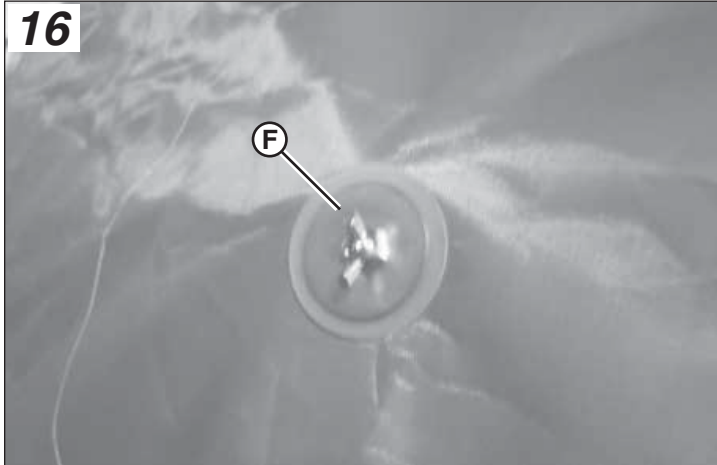

- Pull the loop handles of the securing cable against the locking clamp to tighten the cuff against the underside of the light cage bottom. See Figure 18.

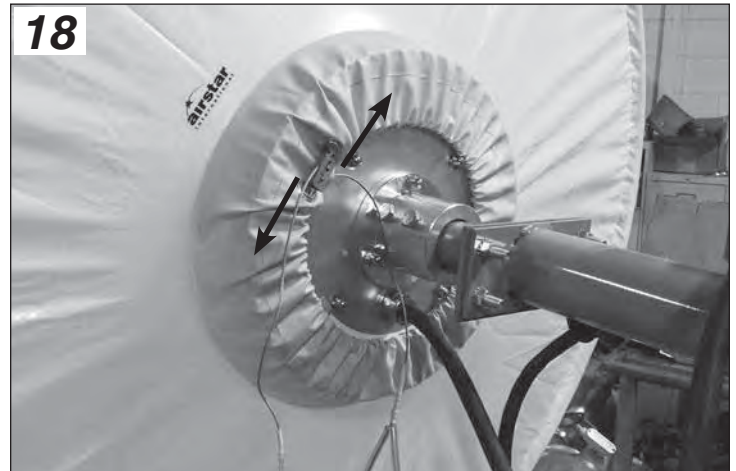

- Connect the light tower cord to the balloon light cord.

Operation

Each lamp is controlled separately by the light tower control panel. Unlike the light fixtures that come standard with the light tower, the balloon light is fixed and cannot be positioned.

Refer to the Operation section of the light tower Operator's Manual for instructions regarding lamp operation.



WARNING

Rollover Hazard

Rollover hazard could result in death or serious injury.

- Using the balloon light reduces maximum continuous wind load by 10 mph (16 km/h). Refer to the light tower operator's manual.

Transporting

The balloon shade and light cage must be removed from the light tower prior to transport.

1. Shut down the light tower, turn off the engine, and allow ample time for the bulbs to cool. Refer to the light tower Operator's Manual.



WARNING

Burn Hazard

Burn hazard could result in death or serious injury.

- Light fixtures and some of the engine surfaces become very hot during operation and shortly after shutdown.
- Keep hands and other body parts away from hot engine surfaces.
- Handle hot components, such as light fixtures, with heat resistant gloves.

*NOTE: On vertical towers, the mounting assembly can be lowered for ease of removal of the balloon light. See **Balloon Light Installation - Vertical Tower Mount Installation**.*

2. Using pliers, hold open the locking clamp at the bottom of the balloon shade, and loosen the cable that keeps the cuff tightened against the underside of the light cage bottom. See Figure 19.

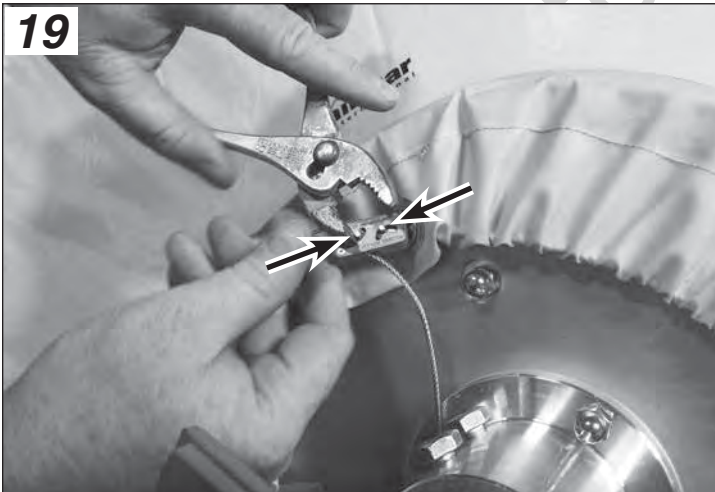

3. Slide the bottom of the balloon shade up until it meets the top of the shade.
4. Remove the wing nut securing the top of the balloon shade to the light cage extension rod, and remove the shade.
5. Replace the wing nut onto the top of the light cage extension rod. Tighten securely.
6. Remove the hoop ribs from the zippered pockets on the top, center, and bottom of the balloon shade.
7. Carefully fold the balloon shade and place in the storage bag.
8. Remove the extension rod from the top of the light cage.
9. Unplug the balloon light cord from the light tower cord.
10. Loosen the jam nuts and securing bolts at the bottom of the light cage, and carefully remove the light cage from the light tower mounting bracket.
11. Carefully store the light cage, extension rod and hoop ribs in the storage case. See Figure 20.

NOTICE

Be careful to store extension rod and hoop ribs away from bulbs, as breakage may occur.

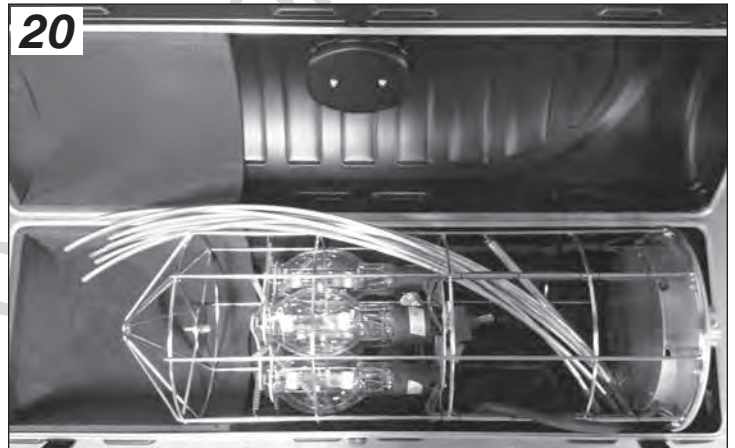

12. Refer to the Transporting section of the light tower operator's manual for the remainder of transporting instructions.

Maintenance

Before performing any maintenance procedures, see **Safety**.

Replacing Bulbs



WARNING

Burn Hazard

Burn hazard could result in death or serious injury.

- The light fixtures become extremely hot during use.
- Always use caution and heat-resistant gloves when handling the lights or allow the lights to sufficiently cool down before handling.

1. Remove the balloon shade to gain access to the light cage. See **Transporting**.
2. Slide the bulb holder toward the top of the light cage to provide clearance for removing and installing the bulb(s). See Figure 21.
3. Remove the burned out bulb(s), and replace with new, using the supplied gloves.

NOTICE

Be careful not to touch bulbs with bare hands, as oil from hands may shorten bulb life.

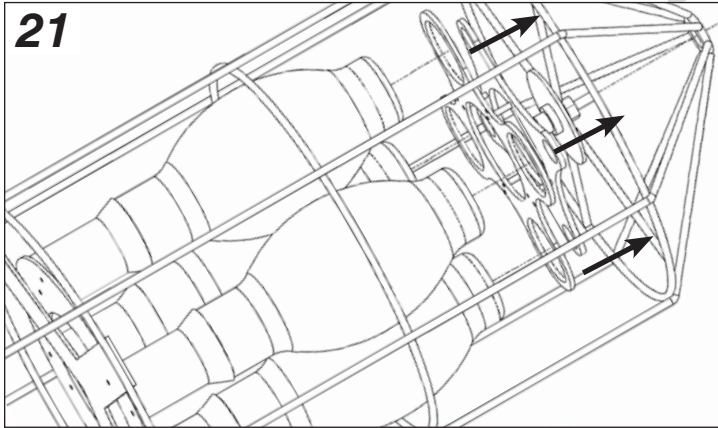

4. Carefully position the bulb holder over the top of the bulbs, using the springs (not shown) to secure the holder in place. See Figure 22.

NOTICE

Use extreme care when positioning the bulb holder, as the springs may cause the bulb holder to snap against the bulbs, causing damage or breakage.

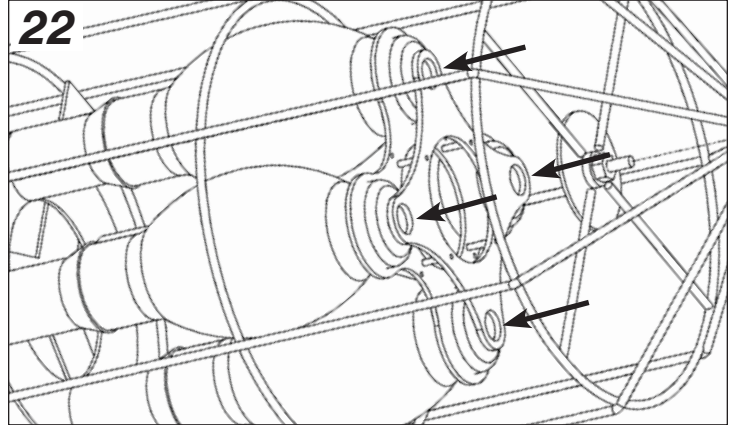

Balloon Shade Repair

1. Cut a patch out of the self-adhesive fabric sheet of the repair kit big enough to entirely cover the damaged area of the shade.
2. Remove the protective film from the self-adhesive side of the patch.
3. Stick the patch onto the damaged area of the shade.

Troubleshooting

Before performing any troubleshooting procedures, see **Safety**.

Problem	Possible Cause	Solution
Lamp(s) not functioning	Power cords not connected	Connect power cords
	Bulb(s) burned out	Replace bulb(s)
For all other issues, contact your authorized dealer.		

Specifications

Height (assembled)*	56 in (142 cm)
Diameter (light cage)*	14 in (36 cm)
Diameter (with balloon shade)*	56 in (142 cm)
Lamps	1250W (4)
Weight*	32 lbs (15 kg)

* Not including mounting components

Not for
Reproduction

This page intentionally blank

Not for
Reproduction

This page intentionally blank

Not for
Reproduction

Not for
Reproduction