

AllmandTM

MAXI-LITE V-SERIES

ML 7.5/ML 8 OPERATOR'S MANUAL

ALLMAND BROS. INC
P.O. BOX 888
HOLDREGE, NE 68949

PHONE: 308/995-4495, 1-800/562-1373
ALLMAND FAX: 308/995-5887
ALLMAND PARTS FAX: 308/995-4883

AllmandTM MAXI-LITE SERIES

For Parts and Updates visit Allmand on the Web at www.allmand.com

INSPECTION CHECK LIST

FOR PREPARING THE MAXI LITE FOR DELIVERY OR RENTAL

The **MAXI LITE V-SERIES** requires service as well as proper operation in order to provide the performance and safety it has been designed for. Never deliver or put a machine into service with known defects or missing instructions or decals. Always instruct the customer in the proper operation and safety procedures as described in the operator's manual. Always provide the manual with the equipment for proper and safe operation.

CHECK LIST:

- Visually inspect the equipment to ensure that all instructions and decals are in place and legible.
- Inspect the tower latch and knob assembly which locks the tower in the vertical position for proper operation
- Check the hitch assembly and safety tow chains
- Check the outriggers and jacks to make sure they operate properly
- Inspect the light assemblies for damage and test for proper operation
- Inspect the electrical wiring for signs of damage
- Check the ground rod cable and the ground lug. Make sure they are clean, undamaged, and functional.
- Inspect the tires to ensure good condition and proper inflation
- Check oil, fuel, coolant levels, and hydraulic fluid levels.
- Check to make sure the operator's manual is with the equipment.
- Inspect the machine physically for damage and repair if necessary.
- Inspect the light bar and latch in transport position.

NOTE: See appropriate section of manual for scheduled maintenance intervals.

After completing the inspection check list, operate the tower through a complete operation cycle, following the operating instructions in the operator's manual.

WARNING

**NEVER ALLOW ANYONE TO OPERATE THE EQUIPMENT WITHOUT
PROPER TRAINING!**

ALWAYS READ THE INSTRUCTIONS FIRST!

TABLE OF CONTENTS

INSPECTION CHECK LIST	2
TABLE OF CONTENTS	3
INTRODUCTION	4
SAFETY SYMBOL INFORMATION	4
SAFETY AND WARNING DECALS.....	5-7
HYDRAULIC LIFT MAST OPERATION	8-10
TOWING AND STARTING INSTRUCTIONS	11-12
SERIAL NUMBER LOCATION	13
SPECIFICATIONS.....	14-16
CONTROLS AND COMPONENTS.....	17-24
ROUTINE MAINTENANCE SCHEDULES.....	25
TROUBLESHOOTING	26
ASSEMBLY PARTS AND ACCESSORIES	27

INTRODUCTION

- This manual provides the information necessary for the safe operation of the Allmand Bros., Inc., **MAXI-LITE V-SERIES** light tower.
- The **MAXI-LITE V-SERIES** standard tower is operated with a 12 VDC hydraulic pump and hydraulic cylinder.
- Specific operating instructions and specifications are contained in this publication to familiarize the operator and maintenance personnel with the correct and safe procedures necessary to maintain and operate the equipment.

Take time to read this book thoroughly. If you are uncertain about any of the information presented in the manual, contact the factory or your dealer for clarification before operation.

SAFETY SYMBOLS

The purpose of the **SAFETY INFORMATION SYMBOL** shown below is to attract your special attention to safety related information contained in the text.

 **DANGER**

 **WARNING**

 **CAUTION**

FAILURE TO UNDERSTAND AND COMPLY WITH SAFETY RELATED INFORMATIONAL INSTRUCTIONS MAY RESULT IN INJURY TO OPERATOR OR OTHERS. IF YOU DO NOT UNDERSTAND ANY PART OF THIS INFORMATION CONTACT YOUR DEALER FOR CLARIFICATION PRIOR TO OPERATING EQUIPMENT.

NOTE

The word **NOTE** is used to bring your attention to supplementary information in relation to various aspects of proper operation and maintenance.

NOTE: Keep this manual accessible during operation to provide convenient reference.

NOTE: Any reference in this manual to **LEFT** or **RIGHT** shall be determined by looking at the trailer from the rear.

SAFETY AND WARNING DECALS

SAFETY WARNING

ALWAYS REPLACE ANY SAFETY AND INSTRUCTION DECALS THAT BECOME DAMAGED, PAINTED, OR OTHERWISE ILLEGIBLE.

Refer to these representations of the safety warning decals used on the MAXI-LITE to insure correct ordering if replacing becomes necessary.

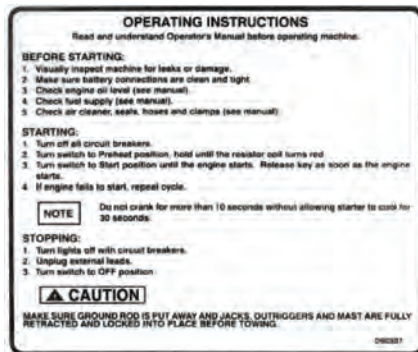

PART NO. 090307
Location: Inside left hand door panel of Caterpillar engine units.

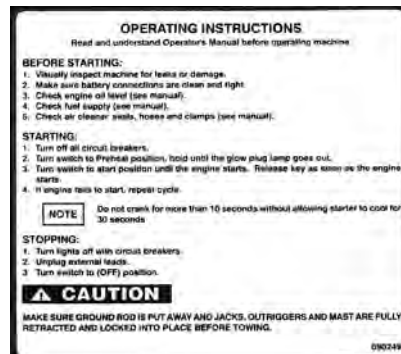

PART NO. 090249
Location: Inside left hand door panel of Kubota engine units.

SETUP TRAILER AND RAISE TOWER

WARNING

CHECK FOR OVERHEAD POWER LINES AND OBSTRUCTIONS BEFORE RAISING TOWER.

1. EXTEND BOTH SIDE OUTRIGGERS. LEVEL TRAILER WITH ALL JACKS.
2. CONNECT GROUND ROD WIRE TO GROUND LUG AND DRIVE GROUND ROD INTO EARTH.
3. RELEASE LIGHT BAR PARK PIN BY PULLING ON RING AND TURNING 90° SO THE PIN REMAINS IN THE RETRACTED POSITION.
4. DIRECT LAMPS TOWARD WORK ZONE BY ROTATING LIGHT BAR AND POSITIONING LAMP FIXTURES.
5. STAND CLEAR OF TOWER WHEN RAISING AND LOWERING.
6. OPERATE TOWER SWITCH UP TO RAISE TOWER TO DESIRED HEIGHT.

LOWER TOWER AND PREPARE FOR TOWING

1. OPERATE TOWER SWITCH DOWN TO LOWER TOWER.
2. STAND CLEAR OF TOWER WHEN RAISING AND LOWERING.
3. ROTATE LIGHT BAR INTO PARK POSITION (IN LINE WITH TRAILER).
4. ENGAGE PARK PIN BY TWISTING ON THE RING UNTIL THE PLUNGER IS RELEASED AND THE PIN ENGAGES THE HOLE IN THE LIGHT BAR.
5. REPOSITION LAMP FIXTURES FOR TRANSPORT BY PULLING THEM DOWN INTO THE LOWEST POSITION AND FACING TOWARD THE CENTER OF THE TRAILER.
6. REMOVE GROUND ROD AND SECURE INSIDE TRAILER.
7. RAISE JACKS AND SWING INTO TRANSPORT POSITION.
8. RETRACT OUTRIGGERS AND SECURE.

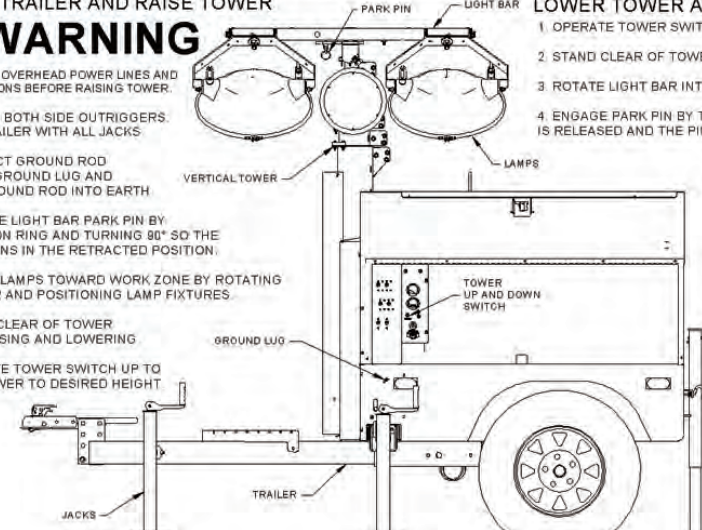

Allmand

For parts and service contact your authorized dealer or visit Allmand on the web at www.allmand.com or call 1-800-562-1373

101925

PART NO. 101925
Location: Inside left hand door panel.

SAFETY AND WARNING DECALS

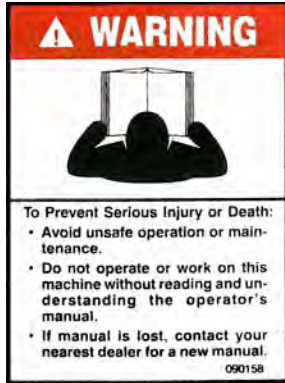

PART NO. 090158
Location: AC control panel



PART NO. 090166
Location: Inside left hand door panel



PART NO. 090163
Location: On left side wheel well



PART NO. 090165
Location: Inside left hand door panel

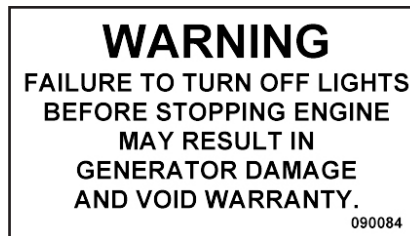

PART NO. 090084
Location: AC control panel



PART NO. 090162
Location: On left front enclosure panel

GROUNDING LUG 090133

PART NO. 090133
Location: On left side panel below ground lug

DIESEL 090034

PART NO. 090034
Location: On left inner fender adjacent to fuel tank filler neck



PART NO. 090226
Location: Left front panel.



PART NO. 090159
Location: On right hand wheel well

SAFETY AND WARNING DECALS



PART NO. 090002
Location: On light bar assembly



PART NO. 090005
Location: Inside left door panel



PART NO. 090160
Location: On trailer drawbar near reversible hitch assembly.

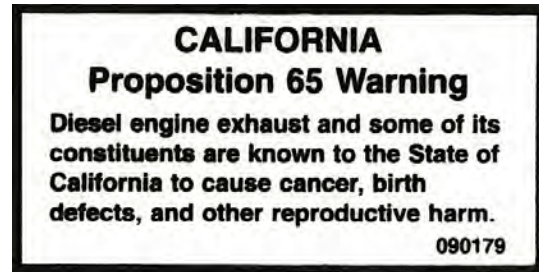

PART NO. 090179
Location: On fuel tank near filler neck.



PART NO. 100247
Location: Inside left door panel.



PART NO. 101404
Location: On either side of mast assembly immediately above roof panel .

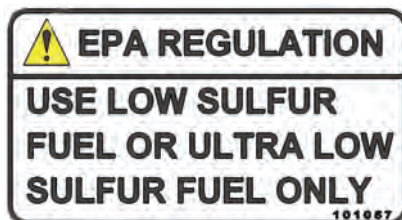

PART NO. 101057
Location: On fuel tank near filler neck.

WINCH



PART NO. 090306
Location: On AC control panel



PART NO. 090465
Location: Inside left door panel.

HYDRAULIC LIFT VERTICAL MAST OPERATION

DESCRIPTION OF OPERATION

The Allmand **MAXI-LITE V Series** hydraulic lift tower assembly consists of a seven section telescoping mast which can be extended by operating a single hydraulic cylinder.

The light bar assembly can be rotated into position by releasing the light bar park pin. To release the park pin, pull the ring and turn it 90 degrees so that the pin remains in the retracted position. The light bar is designed to rotate with enough resistance so that the bar will stay in the desired position once the operator has directed the lights on the work zone. If the light bar rotates too easily or does not stay in position, remove the cap plug from the center of the light bar cover and tighten the nut to achieve the desired resistance and replace the cap plug.



SAFETY WARNING!

- **ALWAYS CHECK FOR OVERHEAD OBSTRUCTIONS BEFORE RAISING AND LOWERING MAST. ALLOW 35' CLEARANCE. AVOID ALL OVERHEAD ELECTRICAL WIRES.**
- **TO PREVENT INSTABILITY AND HELP ENSURE SAFE OPERATION, ALWAYS PROVIDE PROPER GROUND SUPPORT BEFORE RAISING MAST.**

BEFORE RAISING MAST, VISUALLY INSPECT EQUIPMENT FOR DAMAGE OR WEAR. FAMILIARIZE YOURSELF WITH THE LOCATION AND FUNCTION OF ALL OPERATING PARTS BY STUDYING THIS MANUAL. OBSERVE ALL CAUTION DECALS LOCATED ON EQUIPMENT

TO SET UP TOWER AND RAISE LIGHTS

1. Extend both side outrigger jacks, rear jack and tongue jack to stabilize and level the trailer.

NOTE: Jacks should be placed only on firm footing.



SAFETY WARNING!

THE SUPPLEMENTAL GROUND ROD IS A SAFETY DEVICE THAT MAY REDUCE THE CHANCE OF PERSONAL INJURY FROM STRAY ELECTRICAL CURRENT. Therefore, Allmand recommends using the ground rod. However, it is the user's responsibility to determine the requirements and/or applicability of local, state, or national electrical code which governs the use of the ground rod.

2. Attach the ground rod to the grounding lug, and drive the ground rod fully for adequate electrical ground, as required by local, state, or national code.
3. Start engine.(NOTE: Tower may be raised and lowered as needed without engine running.)
4. While the tower is still in the down position, position the light bar and lamps so they are aimed at the work zone and tilted at the approximate angle to get maximum coverage once the tower is raised.
5. Stand clear of the tower when raising and lowering the lights.

HYDRAULIC LIFT VERTICAL MAST OPERATION

6. Operate the hydraulic lift switch to the “up” position to raise tower to the desired height.
7. If lights need to be adjusted for better lighting of the work zone after raising the tower, lower the tower using the “down” switch position and make desired adjustments to the light bar and light fixtures. Raise the tower into position. Repeat this step if necessary.
5. Reposition the lamp fixtures for transport by pulling them down into the lowest position and face the fixtures toward the center of the trailer.
6. Remove ground rod from earth. Disconnect wire from ground lug and secure in trailer
7. Raise jacks and rear stand, retract outriggers and secure for towing

NOTE: Ensure the detent pins are properly engaged in the outriggers before towing.



SAFETY WARNING!

VISUALLY INSPECT EQUIPMENT FOR DAMAGE BEFORE OPERATING. ALLOW ADEQUATE CLEARANCE AROUND TRAILER FOR TOWER AND INSURE THAT NO PERSONS ARE STANDING IN UNDER THE LIGHTS WHEN LOWERING.

TO LOWER TOWER AND LIGHTS

1. Turn off lights.
2. Operate the hydraulic lift switch in the down position to lower the lights to the lowest vertical position. When tower reaches the bottom, run switch for three additional seconds to ensure that the tower is at it's lowest possible position.
3. Stop engine.
4. Rotate the light bar into the transport park position (in line with trailer) and engage the park pin by twisting on the park pin ring until the plunger is released and the pin engages the hole in the light bar.

HYDRAULIC TOWER POWER UNIT

GENERAL START UP INSTRUCTIONS

NOTE: The ports are marked on the casing UP and DN. When facing the power unit with the motor up, plug the right hand, or DN port Jog the motor until the oil flows from the left hand, or up port. If oil does not flow from the UP port, reverse the wire leads on the motor, and repeat. The pump is now primed. Connect the hose (or tubing) to the UP port and tighten. Connect the other hose end to the blind end of a fully retracted hydraulic cylinder. With the hose fitting loose, operate the power unit until oil (and no air) bleeds from the fitting. Tighten the fitting. Refill the reservoir.

HYDRAULIC PUMP

Hydraulic Oil Specifications

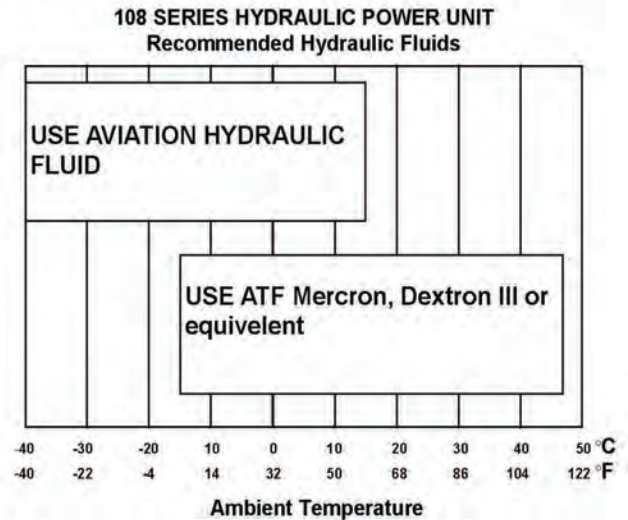

Figure 31

Adding Hydraulic Oil

Fill the reservoir with automatic transmission fluid or any clean hydraulic fluid having a viscosity index that is suitable for the climate conditions in which the unit will be operated. Standard units are supplied with automatic transmission fluid (ATF), and arctic units are supplied with aviation hydraulic fluid (see Figure 31).



Figure 32

TOWING AND STARTING INSTRUCTIONS

TOWING INSTRUCTIONS

Before towing the MAXI-LITE the trailer should be inspected visually to insure that the following operations have been completed.

1. Hitch is securely attached to towing vehicle (safety chains secure).
2. All outriggers and jacks are retracted and secured.
3. Tower is lowered.
4. Light fixtures are positioned for transport.
5. Doors are closed and secure.
6. Check tires for adequate air pressure
7. Taillights are connected and operating (if equipped).
8. Ground rod is removed from ground and secured in the trailer

GROUND ROD INSTRUCTIONS

1. Remove ground rod stowed just inside the left door (attached to the lower rame)
2. Unroll the electrical wire lead from the ground rod.
3. Attach the ground rod lead to the grounding lug located near the ballast compartment.
4. Drive the ground rod a minimum of 2 1/2 FT into the earth for adequate electrical grounding. If this is not possible consult your local qualified electrician.
5. **AFTER SHUTDOWN OF ENGINE:** Remove the ground rod from the earth, remove lead from the trailer ground lug and store ground rod inside left door.

BEFORE STARTING:

1. Fill the engine with the right grade of lubricating oil (refer to the proper page of this manual or the Kubota, CAT, or Lombardini diesel operators manual for oil specifications)
2. Ensure there is an adequate supply of diesel fuel.
3. Ensure that the air cleaner is firmly attached and air cleaner seals and hose clamps are properly sealed. Air cleaner element should be checked and replaced if necessary.

STARTING ENGINE

NOTE: The **Kubota** diesel engine includes a glow plug cold start system controlled by the yellow **preheat** button on the control panel. Glow plugs are not needed on a warm engine or if the ambient temperature is above 50 degrees F. The **CAT C1.1 and Lombardini LDW 1003** diesel engines include a glow plug cold start system controlled by the ignition switch on the control panel. Glow plugs are not needed on a warm engine or if the ambient temperature is above 50 degrees F.

COLD WEATHER STARTING: KUBOTA (for temperatures below 32° F/ 0° C)

1. Turn the on-off switch to the **ON** position.
2. Press the yellow **PREHEAT** button for 5 seconds (10 seconds below 23° F maximum 20 seconds continuous).
3. Press the green **START** button to crank engine until the engine starts.
4. If engine fails to start, it may be necessary to recycle the **PREHEAT** and Start steps #2 and #3 above

STARTING INSTRUCTIONS

COLD WEATHER STARTING: LOMBARDINI LDW 1003 (for temperatures below 32° F/ 0° C)

1. Turn the key switch to the PREHEAT position, hold until the glow plug indicator lamp goes out, then release switch.
2. Turn the key switch to the START position and the engine should start. Release the key immediately when the engine starts. If engine fails to start it may be necessary to cycle the glow plugs again (see chart below)

COLD WEATHER STARTING CAT C1.1 (for temperatures below 32° F/ 0° C)

1. If the engine is cold, turn the key switch counterclockwise to the “preheat” position until the glow plug indicator turns red. **CAUTION: Never heat glow plugs more than 30 seconds or damage to the glow plugs may occur.**
2. Turn the key switch to the “start” position and start the engine immediately once the indicator turns red. Release the key immediately when the engine starts. (If engine fails to start, repeat steps 1 and 2.)

AMBIENT TEMPERATURE	PREHEATING TIME	
	Ordinary Heat Type	With Glow Plug Timer
Above 50°F (10°C)	NO NEED	Automatic preheating is made for about 6
50°F (10°C) to 23°F (-5°C)	Approx 5 seconds	seconds when starter
Below 23°F (-5°C)	Approx 10 seconds	switch key is turned to
Limit of continuous use	20 to 30 seconds	preheating position.

NOTE: Do not operate starter for more than 10 seconds without allowing 30 seconds to pass between starting attempts. Possible starter damage could result from excessive heat caused by cranking too long.

NOTE: If the engine develops sufficient speed to disengage the starter but does not keep running (a false start), the engine rotation must be allowed to come to a complete stop before attempting to restart the engine. If starter is engaged while the flywheel is rotating, the starter pinion and flywheel ring gear may clash, resulting in damage to the starter or flywheel ring gear.

NOTE: If the starter does not turn the engine over, stop cranking immediately. Do not make further attempts to start the engine until the condition is corrected. See your local Kubota, CAT, or Lombardini Engine Service Dealer for trouble analysis.

FOR A WARM ENGINE (Kubota, CAT, and Lombardini engines)

- Follow the same procedure as described for cold weather starting, skipping step 1 (step 2 for Kubota). **Use of the glow plugs is not recommended when engine is warm.**

LOW OIL PRESSURE SHUT-OFF SYSTEM

Should a low oil pressure condition occur, the oil pressure sending unit breaks the circuit between the battery and the fuel solenoid, allowing the spring load to immediately move the fuel control to the shut-off position.

HIGH COOLANT TEMPERATURE SHUT-OFF SYSTEM

Should a high coolant temperature condition occur, the temperature sending unit breaks the circuit between the battery and the fuel solenoid, allowing the spring load to immediately move the fuel control to the shut-off position.

STOPPING THE ENGINE

To stop the engine turn the ignition switch to the off position, this breaks the circuit between the battery and the fuel solenoid, allowing the spring load to immediately move the control to the shut-off position

SERIAL NUMBER LOCATIONS

SERIAL NUMBER LOCATION

Trailer: All MAXI-LITE models have a serial number plate located on the lower left side of the rear panel.

SERIAL NUMBER LOCATION

Generator: The generator has a plate attached to the side of the housing.

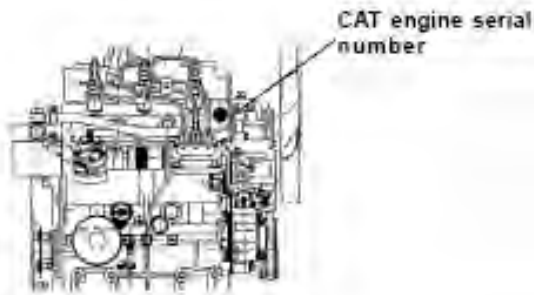

Engine: CAT engines have the serial number stamped on the right side of the engine block just ahead of the first cylinder. (see illustration)



KUBOTA engines have the serial number stamped on the engine block just below the exhaust manifold. (see illustration)

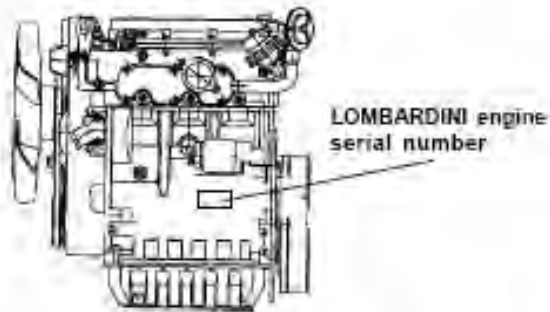

LOMBARDINI engines have the serial number tag located on the right side of the engine block. (see illustration)

SPECIFICATIONS

MAXI-LITE DIMENSIONS

Height lowered:	6'6" (1.98 m)
Height extended:	30' (9.14 m)
Length:	14'9" (4.49 m)
Width:	6'4" (1.92 m)
Outrigger width:	11'6" (3.5 m)
Trailer:	Structural steel frame Leaf spring axle
Wheels & tires:	15"

DOMESTIC SHIPPING WEIGHT

Fixtures:	15 lbs. ea. = 60 lbs.
Total weight:	2,580 lbs. (963 kg)

TRAILER

The engine-generator set is housed in a lockable enclosure with the frame fabricated from heavy gauge steel mounted on a two-wheel leaf spring axle. The design enables the trailer to contain the outriggers in a simple compact position. The design includes an adjustable-height reversible hitch that includes a 2" ball and a 3" pintle hook hitch.

MAST

When the mast is in the operating position it is located in the middle of a three point outrigger system for optimum balance and stability.

The mast consists of seven fabricated steel sections that telescope to 25 ft and UHMW plastic guide pads to provide smooth operation and reduced friction. The mast sections are extended with either a manual or electric winch, or hydraulic pump. The electric winch design includes limit switches that turn the winch off when the mast reaches full extension or is fully retracted.

STABILIZERS

Four (4) point outrigger design with tower center mounted between two (2) retractable side outriggers, tongue jack and rear jack.

FLOOD LIGHT ASSEMBLY

The flood light assembly consists of four 1250 watt lamp fixtures sealed for all weather use.

SHO 1250 fixture - Metal Halide Lamp

- Lumen rating: 150,000 initial lumens
- Warm up time: 2-4 minutes
- Restart time: 10-15 minutes

SPECIFICATIONS

ENGINE SPECIFICATIONS

MODEL	KUBOTA D1105	LOMBARDINI LDW 1003	CAT C1.1
TYPE	Water cooled 4-cycle diesel	Water cooled 4-cycle diesel	Water cooled 4-cycle diesel
BORE	2.99" (76 mm)	2.96" (75 mm)	3.03" (77 mm)
STROKE	2.90" (73.6 mm)	3.05" (77.6 mm)	3.19" (81 mm)
DISPLACEMENT	61.1 cu. In (1002 cc)	62.6 cu. In (1028 cc)	69 cu. In (110 cc)
POWER @ 1800RPM	13.6 HP (11.4kw)	13.4 HP (11.2kw)	14.3 HP (11.9kw) non derate
POWER OUTPUT DERATING	3% per 1000 ft above 360 ft. 1% per 10° above 77° F	3% per 1000 ft above 360 ft. 1% per 10° above 77° F	3% per 1000 ft above 360 ft. 1% per 10° above 77° F
FUEL SYSTEM	Indirect injected diesel	Indirect injected diesel	Cassette type fuel injected diesel
STARTING SYSTEM	12 volt DC	12 volt DC	12 volt DC
COMPRESSION RATIO	22:1	22.8:1	22:1
WEIGHT	205 lbs (93 kg)	191 lbs (87 kg)	191 lbs (87 kg)
OIL CAPACITY	5.4 qt. (5.1 L)	2.5 qt. (2.4 L)	3.9 qt. (3.7 L)
LUBRICATION	Forced lubrication by pump	Forced lubrication by pump	Forced lubrication by pump
OIL FILTRATION	Cartridge type	Cartridge type	Cartridge type
COOLING SYSTEM	Pressurized radiator, forced circulation with water pump	Pressurized radiator, forced circulation with water pump	Pressurized radiator, forced circulation with water pump

- Low oil pressure and high engine temperature shut-downs are standard equipment. Both The Kubota, CAT, and Lombardini diesel are equipped with glow plug cold start assist as standard equipment.

NOTE: See the appropriate section of this manual for cold weather starting instructions or consult the Operators Manual for your particular engine application.

Horsepower ratings are established in accordance with Society of Automotive Engineers Small Engine Test Code- J1349 GROSS.

SPECIFICATIONS

GENERATOR

- 7.5 kw and 8 kw models available
- 60 hz and 50 hz models available

FUEL REQUIREMENTS

Use a clean No. 2 Diesel fuel oil (SAE J313 JUN87) according to ASTM D975. Do not use alternative fuel, because its quality is unknown or it may be inferior in quality, and kerosene, which is very low in cetane rating, adversely effects the engine. Refer to the Kubota, CAT, or Isuzu Operators Manual for more detailed fuel requirements.

LOMBARDINI LUBRICATION CHART

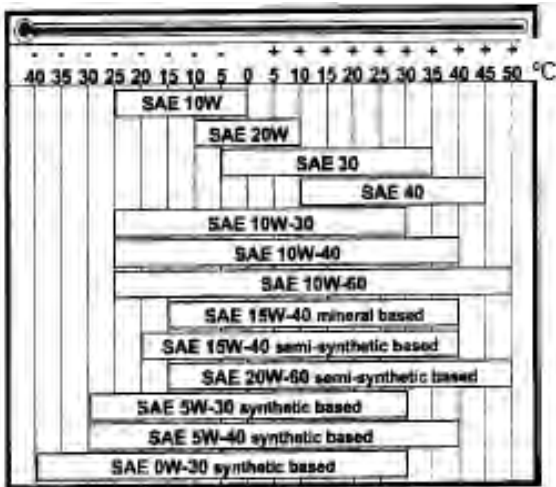

CAT LUBRICATION CHART

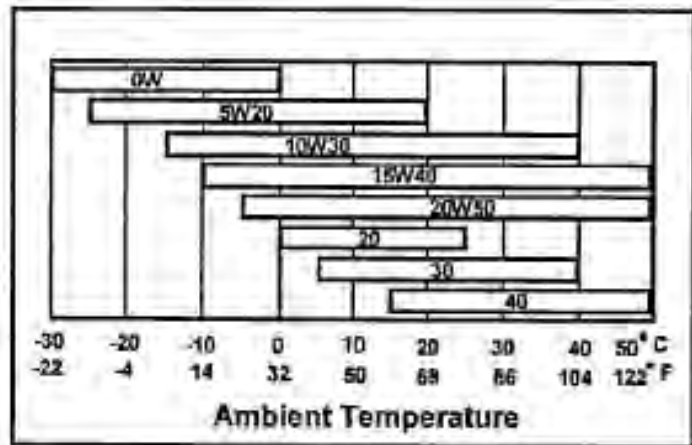

KUBOTA LUBRICATION CHART

above 77°F (25°C)	SAE30 or SAE10W-30 SAE10W-40
32°F (0°C) to 77°F (25°C)	SAE20 or SAE10W-30 SAE10W-40
below 32°F (0°C)	SAE10W or SAE10W-30 SAE10W-40

CONTROLS AND COMPONENTS

NOTE: COMPONENTS SHOWN ARE STANDARD. PICTURES MAY VARY WITH DIFFERENT OPTIONS.

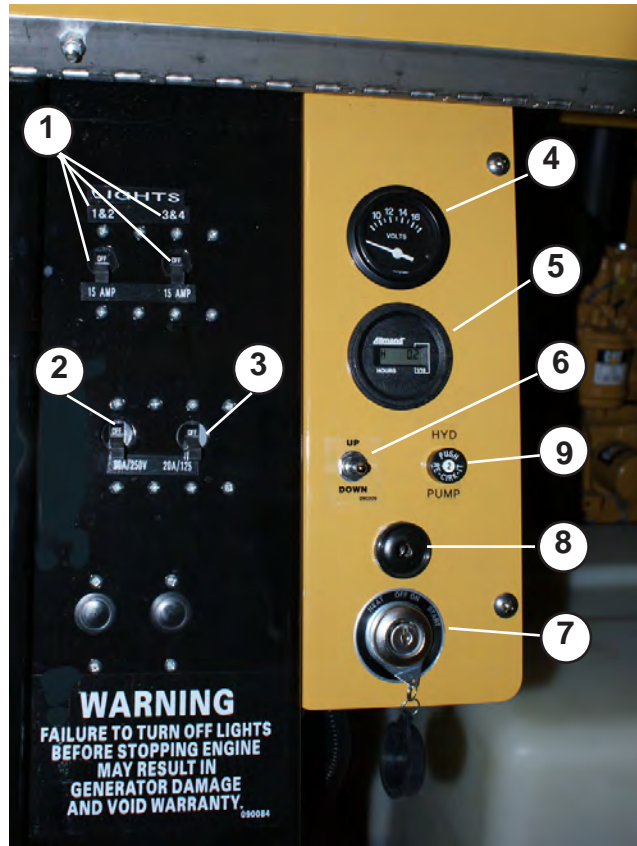

FIGURE 1

FIGURE 2

FIG. 1. AC CONTROL PANEL

1. Switch, Circuit Breaker (Lights 1 through 4)
2. Switch, Circuit Breaker (240V Receptacle)
3. Switch, Circuit Breaker (120V Receptacles)



SAFETY WARNING

FAILURE TO UNDERSTAND AND COMPLY WITH SAFETY RELATED INFORMATION AND INSTRUCTIONS MAY RESULT IN INJURY TO THE OPERATOR OR OTHERS. IF YOU DO NOT UNDERSTAND ANY PART OF THIS CONTACT YOUR DEALER FOR CLARIFICATION PRIOR TO OPERATING EQUIPMENT.

FIG. 2. DC CONTROL PANEL

4. Voltmeter (optional)
Indicates charging circuit voltage
5. Hour Meter
Shows total elapsed hours of engine operation.
6. Momentary Contact Switch. Lift up to raise and extend the tower.
Press down to lower the tower.
7. Ignition Switch
8. Glow plug indicator
release Ignition switch when indicator begins glowing.
9. 2 AMP Circuit Breaker (Hydraulic Pump)

CONTROLS AND COMPONENTS

NOTE: COMPONENTS SHOWN ARE STANDARD. PICTURES MAY VARY WITH DIFFERENT OPTIONS.

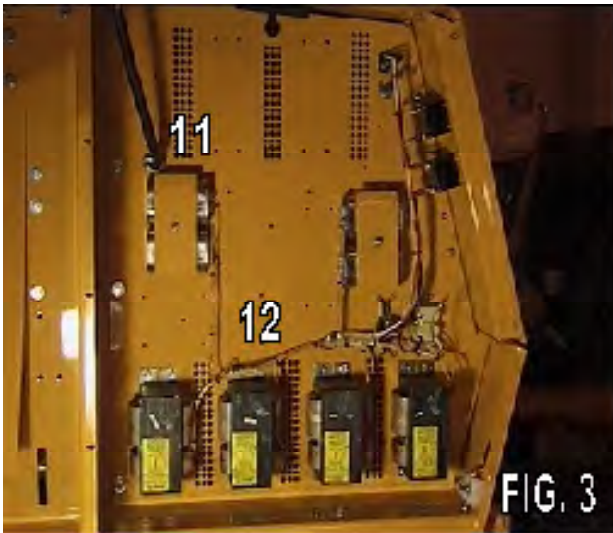

FIG. 3 BALLAST PANEL

- 11. Ballast, Capacitors 1 through 4
- 12. Ballast, Transformers 1 through 4



FIG. 4 CONVENIENCE PANEL

- 13. 120 Volt/ 15 Amp Outlet Receptacles (Ground fault)
- 14. 240 Volt/ 15 Amp D.C. Outlet Receptacle



SAFETY WARNING

FAILURE TO UNDERSTAND AND COMPLY WITH SAFETY RELATED INFORMATION AND INSTRUCTIONS MAY RESULT IN INJURY TO THE OPERATOR OR OTHERS. IF YOU DO NOT UNDERSTAND ANY PART OF THIS CONTACT YOUR DEALER FOR CLARIFICATION PRIOR TO OPERATING EQUIPMENT

CONTROLS AND COMPONENTS

NOTE: COMPONENTS SHOWN ARE STANDARD. PICTURES MAY VARY WITH DIFFERENT OPTIONS.

FIG. 5 GROUND ROD

16. Ground Rod

Ground Rod should be attached to grounding lug with wire provided and ground rod and then driven fully into the earth for adequate electrical ground as required by local, state or national electrical codes.

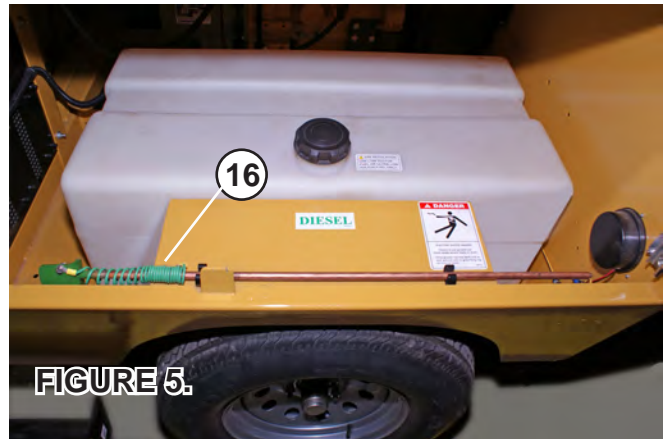

FIG. 6 ENGINE (Left Side)

17. Air Cleaner

18. Fuel Filter

19. Oil Filter

20. Radiator

21. Oil Dipstick

22. Oil Pressure Sensor

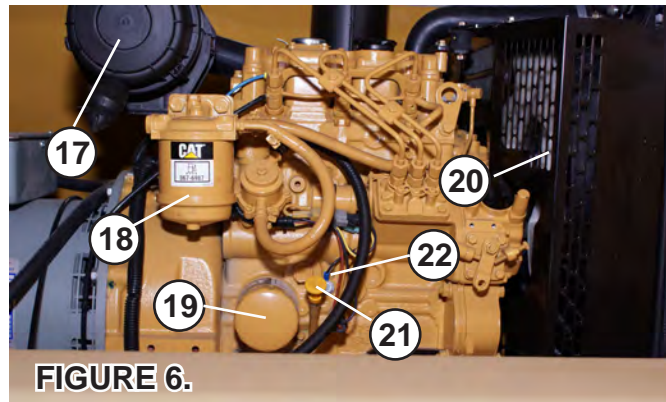

FIG. 7 ENGINE (Right Side)

23. Starter

24. Alternator

25. Muffler

26. Air Cleaner Service Indicator

27. Coolant Temperature Sensor

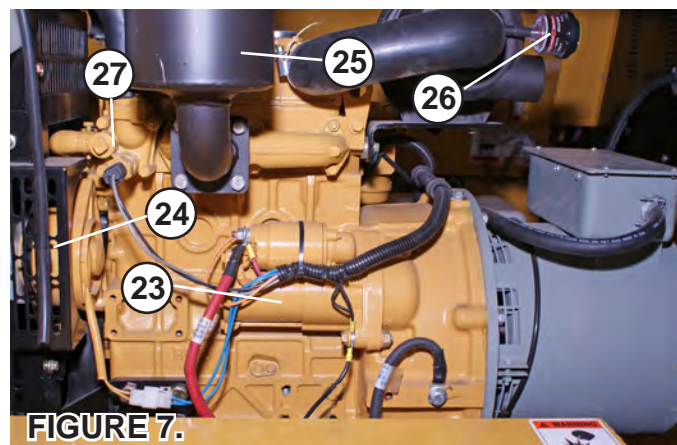

NOTE: Above photos illustrate component locations on the CAT C1.1 diesel engine. Component location on other engine models may vary from the locations indicated above.

CONTROLS AND COMPONENTS

NOTE: COMPONENTS SHOWN ARE STANDARD. PICTURES MAY VARY WITH DIFFERENT OPTIONS.

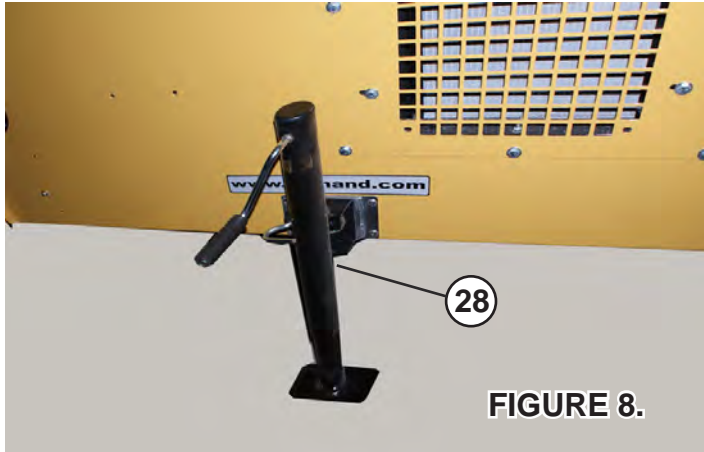

FIG. 8 REAR JACK

28. Rear Jack

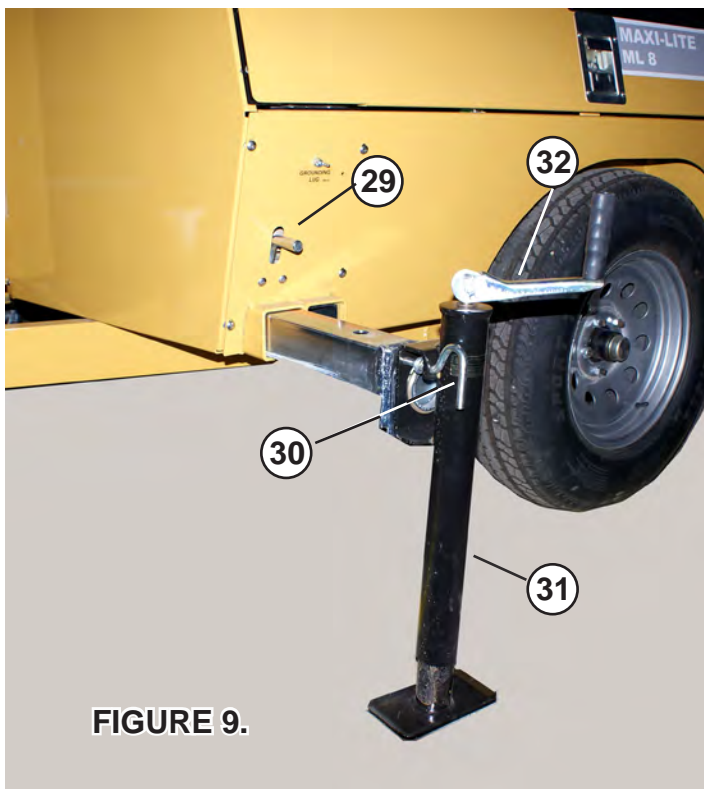

FIG. 9 OUTRIGGER JACK

29. Pin--Retains outrigger in retracted position for towing.

30. Jack Pin--Pull to allow jack to rotate

31. Outrigger Jack

32. Jack Handle--Crank handle to raise and lower foot of jack to level trailer.

CONTROLS AND COMPONENTS

NOTE: COMPONENTS SHOWN ARE STANDARD. PICTURES MAY VARY WITH DIFFERENT OPTIONS.

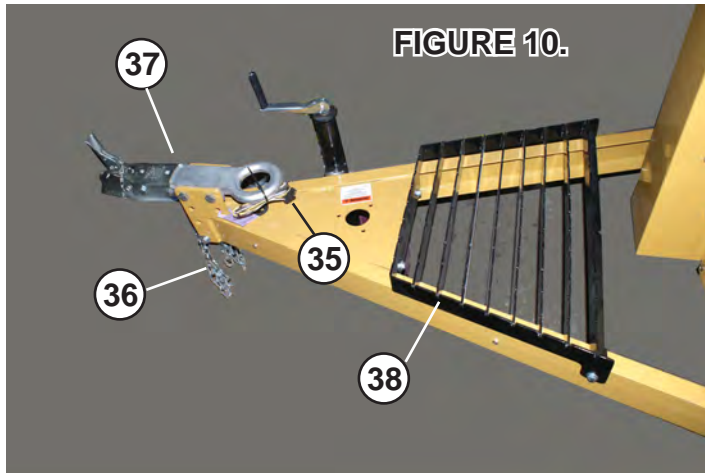

FIG. 10 TONGUE ASSEMBLY

- 35. Taillight Wiring Harness
- 36. Safety Tow Chains
- 37. Reversible Hitch (2" Ball and 3" Pintle Hitch)
- 38. Step Plate--Allows operator to position light fixtures prior to raising tower.

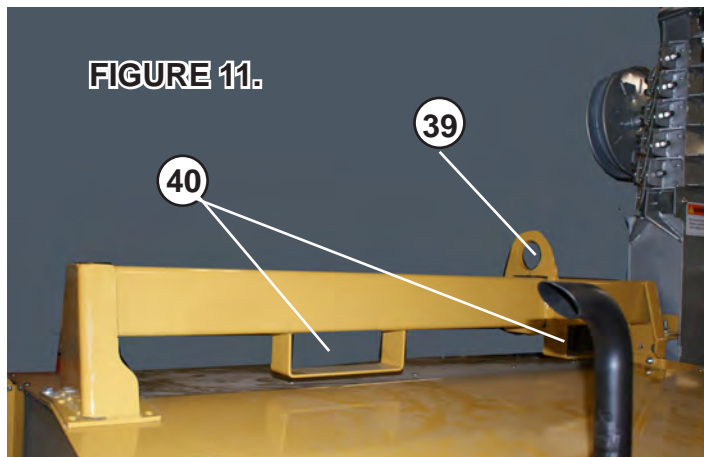

FIG. 11 FORKLIFT POCKETS

- 39. Lifting Eye
- 40. Forklift Pockets

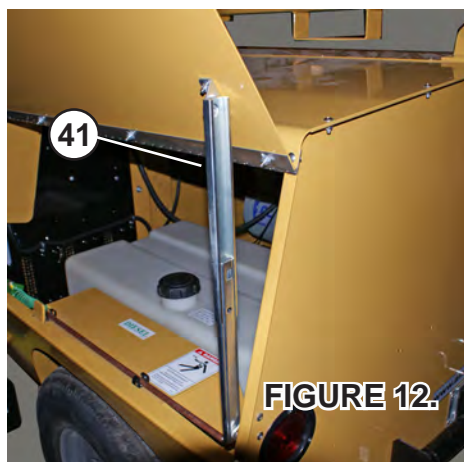

FIG. 12 DOOR PROP

- 41. Door Prop--Locks door panel in open position.

CONTROLS AND COMPONENTS

NOTE: COMPONENTS SHOWN ARE STANDARD. PICTURES MAY VARY WITH DIFFERENT OPTIONS.

Fig. 13. Hydraulic Bypass Valve

- 41. Bypass Valve
Allows tower to be lowered manually in the event of a failure.

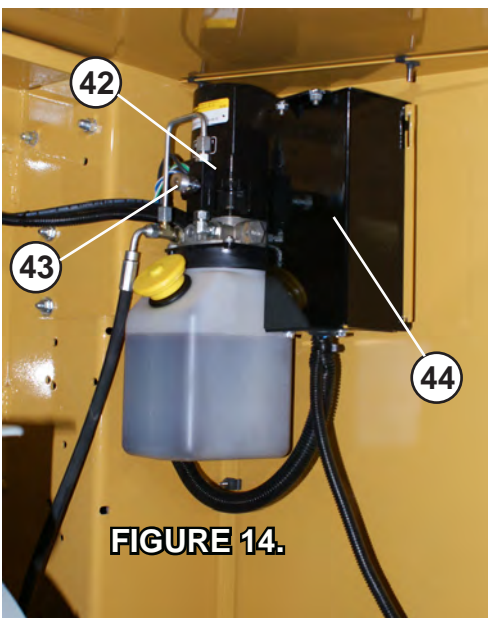

Fig 14. Hydraulic Power Unit Assembly

- 42. Hydraulic Pump
- 43. Bypass Valve
- 44. 12 VDC Enclosure
Houses 125A fuse and 100A solenoid

CONTROLS AND COMPONENTS

NOTE: COMPONENTS SHOWN ARE STANDARD. PICTURES MAY VARY WITH DIFFERENT OPTIONS.

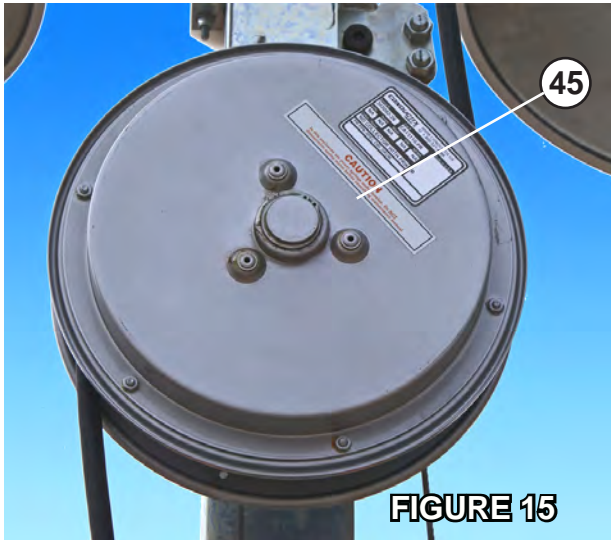

FIG. 15 Cord Reel

45. Cord reel —*Manages the mast power cable and prevents tangling.*

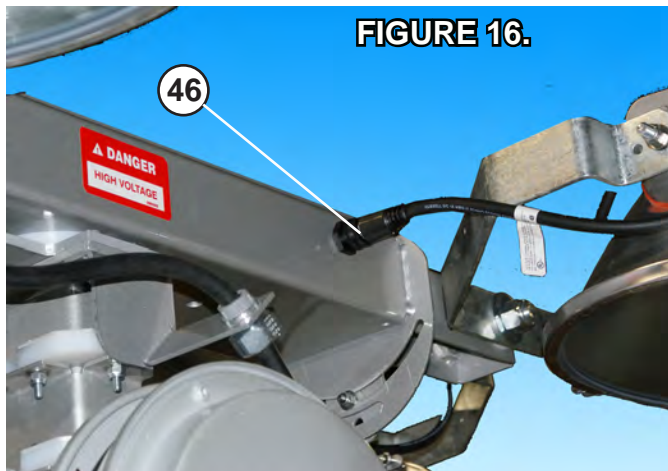

FIG. 16 Light Bar

46. Lamp Connector Lead—*Allows quick connecting/disconnecting of the lamp fixtures*

CONTROLS AND COMPONENTS

NOTE: PHOTOGRAPHS MAY SHOW NON-STANDARD EQUIPMENT AND OPTIONS

FIG. 17 Vertical Tower

- 1. Seven Section Vertical Tower**
- 2. Light Mounting Locations** --Mount lights here for use during operation
- 3. Light connector sockets**—attach light leads to light bar at these female receptacles when provided

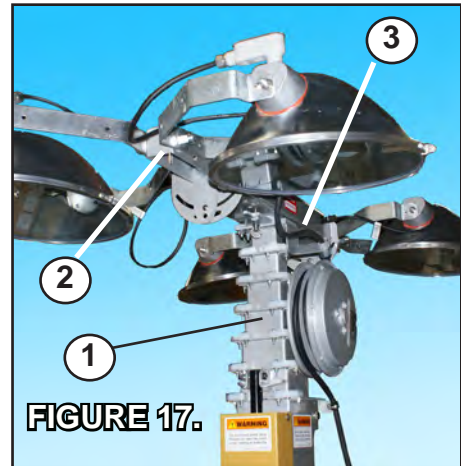
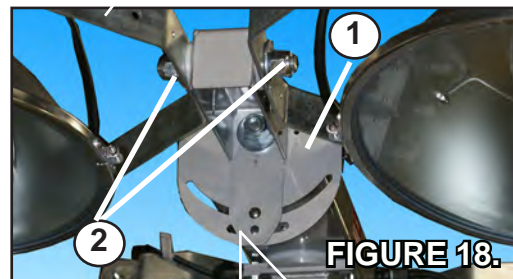

FIG. 18 Light Bar and Mounting Locations

- 1. Light Bar**
- 2. Light mounting locations** —Mount lights here for use during operation



TROUBLESHOOTING



SAFETY WARNING

DANGER!

HIGH VOLTAGE! DO NOT ATTEMPT TO TEST AND REPAIR GENERATOR AND BALLAST ELECTRICAL SYSTEMS UNLESS YOU UNDERSTAND AND ARE QUALIFIED TO WORK ON SUCH SYSTEMS.

DO NOT WEAR JEWELRY WHILE WORKING WITH ELECTRICITY! If the following procedures do not solve your problem, have the circuit tested by a licensed electrician. **DO NOT** attempt to test generator voltage or ballast electrical systems unless you are a qualified electrician. Consult the factory for voltage specifications and test procedures

PROBLEM	POSSIBLE CAUSE
ONE OR MORE LIGHTS DO NOT LIGHT UP.	1. Circuit breakers in the outlet box are not turned on or have tripped.
	2. Lamps are not allowed time to cool after last being lit. You must allow 15 minutes between the time the lights are shut off and the time they are restarted.
	3. The lamp or lamps are burned out or broken.
	4. One or more of the lamps are not screwed in securely.
	5. Plug and socket at light bar not securely pushed together and locked.
	6. The temperature of the ballast is below -20 degrees F. the efficiency of the capacitors in the ballast is not enough to ignite the lamps. For operations where the temperatures of the ballasts falls below -20 degrees F. some means of warming the ballast must be used.
	7. Low electrical system voltage.
	8. A loose connection in the back of the lamp socket in the lamp holder.
	9. A circuit breaker or breakers are defective.
	10. A loose connection on the terminal board.
	11. The engine and generator are not running up to speed (1800 RPM)
	12. A wrong style replacement lamp (requiring a different ballast) has been installed.
	13. Too much power is being drawn from the auxiliary outlets.
	14. Capacitor or transformer have failed.
	15. Corrosion has occurred on the lamp bases.

For engine and generator troubleshooting, see engine and generator manuals or contact your dealer.