



LSC100

LIGHT SEQUENCE COMMANDER

Operation, Testing, and Troubleshooting Information

**ALLMAND BROS. INC
P.O. BOX 888
HOLDREGE, NE 68949**

**PHONE: 308/995-4495, 1-800/562-1373
ALLMAND FAX: 308/995-5887
ALLMAND PARTS FAX: 308/995-4883**

 **LSC100 Light Sequence Commander**

TABLE OF CONTENTS

Start Instructions	Page 3
Description of Operation and Instructions	Page 4
Programming Instructions for Optional Timer	Page 5
LSC100 Features and Benefits	Page 6
Description of Load Sequencing	Page 7
LSC100 Testing Procedure	Page 8
Parts List	Page 9
Wiring Schematic for Kubota/LSC100	Pages 10-14
Wiring Schematic for Cat/Perkins/LSC100	Pages 15-19
LSC100 Logic Sequence Flow Chart	Page 20

Manual Start Instructions

1. Turn power switch ON
2. Turn light circuit breakers ON
3. Turn Auto/Manual switch to MANUAL

NOTE:

- *Glow plugs are automatic as required
- *Engine will start or make 5 attempts
- *Lights will come on when engine water temperature reaches 120° F.

Shut Down

1. Turn Auto/Manual switch OFF
2. Turn power switch OFF

Automatic Start Instructions

1. Turn power switch ON
2. Turn light circuit breakers ON
3. Turn Auto/Manual switch to AUTO (Start sequence will begin when photocell senses preset light value)

NOTE:

- *Glow plugs are automatic as required
- *Engine will start or make 5 attempts
- *Lights will come on when engine water temperature reaches 120° F.

Shut Down

1. Turn Auto/Manual switch OFF
2. Turn power switch OFF

Description of Operation and Instructions LSC100 Light Sequence Commander

The Allmand LSC100 Light Sequence Commander includes an engine auto start controller and a light circuit controller in one package. The LSC100 features 5 LEDs on the face of the control panel indicating the following from left to right.

1. Flashing red (alarm)
2. Red (glow plug)
3. Yellow (crank)
4. Green (fuel)
5. Red (power)

TO START THE UNIT MANUALLY, turn the power switch to the up ON position and place the Auto/Manual switch to MANUAL.

The controller will check the fuel level. If insufficient fuel is present, the control will not start and indicate an alarm by flashing the red LED. Fuel must be added before the unit will start. If sufficient fuel is present, a glow plug relay is closed for a period of time and the red LED is illuminated. Glow plug on time is specific to the engine model and determined by the engine water temperature. Kubota installations have a maximum of 10 seconds, Isuzu installations have a maximum of 5 seconds, and the Cat 3003/Perkins 103-10 have a maximum glow plug on time of 60 seconds. The glow plug on time must be set specifically for the engine requirements during installation. After the glow plug cycle, the fuel and crank relays close.

Once the controller detects frequency, the crank relay opens and the fuel relay remains closed. If the engine does not start after five crank cycles with a 10 second rest, an overcrank fault occurs and the red LED flashes. Once the water temperature reaches 120°F, the light relays begin to close sequentially, with a three-second delay in between. (NOTE: Light circuit breakers must be in the ON position or the lights will not come on.) If the fuel level in the tank falls below 1/10 full, the shut down sequence will begin. The low fuel fault will be indicated by a flashing red LED. It will remain flashing until the fuel is replenished above 20 percent.

If oil pressure falls below minimum levels while running an oil pressure fault will occur, All light circuits and engine relays will then open and the engine will shut down. The fault will be indicated by the flashing red LED. To clear the fault, position the Auto/Manual switch in the center OFF position. Temperature is also monitored through the sender. If a temperature above 234° F. is detected, a high temperature fault will occur. The fault will be indicated by the flashing red LED that will clear after the Auto/Manual switch is placed in the center OFF position.

TO START THE UNIT AUTOMATICALLY, turn the power switch to the up ON position and place the Auto/Manual switch to Auto. This allows the unit to be remotely started by the standard photocell. Optional remote devices can include a day timer or a wireless communication unit.

Placing the ON/OFF switch or the Auto/Manual switch to the OFF position starts the shutdown sequence that lasts approximately 30 seconds.

If the light tower is equipped with the photocell and a timer, the control panel will include an additional switch that will select the source of control, either timer or photocell.

PROGRAMMING INSTRUCTIONS FOR OPTIONAL ALLMAND LSC100 TIMER

The Allmand **LSC100 Light Sequence Commander** can be equipped with an optional 7 Day, 8 Event, programmable timer.

OVERVIEW

The LSC Timer allows full ON/OFF control of the LSC equipped light tower. The lights can be turned ON and OFF at specific times of the day and as many as 8 times a day. The timer can also be programmed for a specific day of the week or any combination of days.

SETTING TIME

To set the clock to your local time and the day of the week:

1. Press the **CLOCK** button and hold throughout the following steps.
2. Set the Day of the Week by pressing the **DAY** key until the correct day appears.
3. Set the **HOURL** by pressing the **HOURL** key until the desired **Hour** appears.
4. Set **MINUTE** by pressing the **MIN** key until the desired minute appears.
5. When the time and day is set, release the **CLOCK** key.

PROGRAMMING

1. Pressing the **TIMER** key will enter the Program mode. Pressing the **TIMER** key will scroll through the events. Stop on the event you want to set. There are 8 events and an ON and OFF time for each event.
2. Press **DAY** key to select the day or group of days. Press the **HOURL** key to set the hour and the **MIN** key to set the minute.

NOTE: You may never need to use more than 1 event ON and OFF per day. However the timer is capable of 8 event pairs per day. Always set an **OFF** time for each **ON** time.

NOTE: To clear the event, press the **TIMER** key until you get to the event you want to clear and hold, then press the **DAY** key until the setting clears.

Always set an **OFF** time for each **ON** time. It is possible to have one **OFF** event for several **ON** events. For example, if you want to have the lights come on at different times each day but go off at the same time every day, one **OFF** event is all that is needed as long as it covers all of the **ON** days.

When the programming is complete, press the **CLOCK** key.

The **MANUAL** key on the timer will select **ON**, **AUTO**, and **OFF**. Position the black bar in the display window over the desired function. **For Automatic operation of the timer it must be set to AUTO.**

With the LSC set with Power Switch **ON** and the AUTO/MANUAL switch to **AUTO**, the **MANUAL TIMER** key can be used to initiate the start sequence by pressing the **MANUAL** key until it indicates **ON**. The shutdown sequence can also be initiated by pressing the **MANUAL** key to indicate the **OFF** position.

All programming and time can be reset to new settings by pushing the **RESET** button with a pencil or pen.

NOTE: All programming will be lost when button is pushed

ALLMAND LSC100 LIGHT SEQUENCE COMMANDER Features and Benefits

GENERAL DESCRIPTION:

The LSC100 Light Sequence Commander includes an engine auto start control and a light circuit controller in one package. The control provides for complete automatic light tower operation once the machine is set up on the job site. The controller can be equipped with a seven-day programmable timer, photocell, or a wireless communication unit.

FEATURES and BENEFITS

1. **Engine Auto Start:** allows the light tower to automatically turn itself ON and OFF as desired with the standard photocell, available timer, or wireless device.
2. **Automatic Glow Plug Smart System:** Operates the glow plugs when and as needed by monitoring the engine water temperature. Operator will not over apply the glow plugs and possibly burn them out or apply the glow plugs when the engine is warm and does not require glow plug operation. The Allmand LT-100 controller is adaptable to meet the glow plug requirements of different engines.
3. **Integrated low oil pressure shut down:** If the oil pressure falls below a specified minimum it will initiate the automatic shut down sequence.
4. **Integrated high water temperature shut down:** If the water temperature exceeds the maximum acceptable level it will initiate the shut down sequence.
5. **Low fuel level shutdown:** When the fuel level reaches approximately 10 percent capacity it will initiate the automatic shut down sequence.
By shutting down the light tower before completely running out of fuel the generator is protected from being shut down while being under load, and when refueled the engine will not require bleeding of the fuel system and the possible starter and solenoid failures as a result of overcranking.
6. **Sequenced light control:** Lights will come on automatically after the engine is started and will turn off automatically before engine is shut down. This provides protection for the generator because the load will be OFF before the engine is shut down.
7. **Diagnostic LED Fault indicator:** The control panel includes a red flashing LED alarm on the control panel to indicate that the light tower was shut down by a fault. The fault LED could indicate a shut down due to low fuel level, low oil pressure, high water temperature or failure of the engine to start during the automatic start sequence.
8. **Smart Crank engine starter protection:** The automatic start sequence will make five attempts to start the engine with a 10-second rest between attempts. If the engine does not start after 5 attempts it will turn ON the LED fault indicator.

AVAILABLE CONTROLS

1. **Photocell control:** The photocell is set to start the light tower at dusk and turn the light tower off at dawn. With this option the operator simply turns the controller power switch to ON with the Auto/Manual switch set for automatic function, The light tower will start and or shut down whenever the ambient light is at the preset values. The photocell is specifically located so will not be affected by the light produced by the tower and includes a delay so it is not affected by headlights or other sources of light.
2. **Seven-day programmable timer:** The seven-day programmable timer allows the light tower to be started or shut down as desired. The operator can program the timer for as many as 8 events per day. The programmer can also select specific days or groups of days as desired.
3. **Wireless communication:** The light tower can be equipped with a wireless communication device that will allow the light tower to be controlled remotely.

ALLMAND LSC Light Sequence Controller

SEQUENCING ON

Generally an engine-driven generator is required to start with a load connected. It is not uncommon for the load to be applied to the generator all at one time as the engine is coming up to speed. It is also common for a generator set to have a fixed RPM in order to maintain a required frequency, usually 1800 or 3600 RPM. As a result of these requirements the engine starting system can have additional loads that can result in premature failures of the starter motor due to overcranking. In addition the typical diesel engine would include a fuel solenoid that controls the flow of fuel to the engine electrically. The fuel solenoid typically includes a pull coil that retracts a mechanism to allow fuel flow when the engine starter is cranked. Excessive engine cranking and excessive engagement of the pull coil in the fuel solenoid can result in overheating and burnout of the pull coil.

By having no load, or sequencing the loads on, the engine starter and solenoid will not be affected.

Benefits of Sequencing the Loads ON:

1. Potentially less requirements on the engine starter.
2. Less cranking of the starter and faster starts results in less coil failures in the solenoid.
3. A smaller horsepower rated engine may be adequate due to no load during engine start.
4. A smaller horsepower rated engine may be used as the loads can be sequenced on as some types of loads have higher starting loads than running loads such as electric motors etc.
5. A smaller generator may be used as the loads can be sequenced on. Some types of loads require a significant inrush to start such as electric motors, etc.
6. The engine can be started and allowed to warm up before loads are applied.
7. The engine oiling system will be allowed to build up to normal oil pressures before the load is applied.

AUTOMATIC LOAD SEQUENCING OFF

Generally an engine generator set will have the potential to be shut down while under load. This could be the result of the operator's failure to disconnect the load prior to shut down or as a result of the automatic shutdown due to low oil pressure, high water temperature, or running out of fuel. Loads applied to the generator during engine shutdown can result in failure of the generator regulation system as the regulator attempts to maintain the generator output while the RPM is decreasing to zero.

By automatically sequencing the loads off before the engine is shut down, the generator regulation system will not be affected. Sequencing the loads off can occur during manual shutdown or during any automatic shutdown such as low oil pressure, high water temperature, or low fuel.

Benefits of sequencing the loads OFF.

1. Regulation system is not damaged as no loads are applied during shutdown.
2. Engine can be allowed to cool down with no load before shutdown. This can be especially important in turbocharged applications to prevent cooking the oil in the turbo.
3. Generator can be allowed to cool down with no load before shutdown.

By combining the automatic load sequencing ON and OFF with an engine auto start control any machine attended or unattended can be assured of these benefits.

LSC Light Sequence Commander Testing Procedure

The following information can be used for diagnostic evaluation and testing:

- 1. Overcrank:** Remove the yellow 16 ga. wire from the starter. Place the power switch to the ON position and place the Auto/Manual switch to manual. After 5 start attempt cycles of the crank relay, the fuel and crank relay will remain open and the red alarm LED will flash. The toggle switch must be reset to OFF to clear the alarm. Reconnect the Yellow wire to the starter for operation after completing this test.
- 2. Low Oil Pressure Shutdown Circuit:** Start the engine and ground the tan 16 ga. wire on the oil pressure switch by removing it from the NC terminal and temporarily attaching it to the NO contact on the switch, effectively taking the wire to ground. This will cause a shutdown after 3 seconds. All light relays will open and the green LED will turn OFF. The red alarm LED will be flashing. You must reconnect the tan wire to the NC terminal and reset the toggle switch to OFF to clear the alarm. (There will be no sequencing of the lights).
- 3. High Temperature:** Start the Engine and ground the wire on the temperature sender. This will cause a shutdown after 5 seconds. All light relays will open and the green LED will turn OFF. The red alarm LED will be flashing. You must reset the toggle switch to OFF to clear the alarm. (There will be no sequencing of the lights).
- 4. Low Fuel Level: Start Inhibit** can be checked by removing the wire from the sending unit. The red alarm LED will be flashing. Place the ON/OFF toggle switch in the ON position. Place the Auto/Manual switch in the Manual position. The unit will not start. The red alarm LED will continue to flash until the wire is reattached to the sender and sufficient fuel is in the tank.
- 5. Low Fuel Level: Sequenced shutdown** can be checked by starting the engine and allowing the lights to turn on. After the lights are on, remove the wire from the Fuel Sender and the unit will begin to sequence the lights OFF at three-second intervals (2 Lights at a time if the machine has two lights on each breaker). The red LED will also be flashing. Within 30 seconds from the time the wire is removed, the engine will stop. The wire must be reattached to the fuel sender to clear the alarm.
- 6. Fuel Sending Unit:** Using a wire with a hook bent on one end, simply depress the float in the tank to below the 10 percent level. This should initiate the shutdown sequence by shutting the lights off first. The engine should be shut down approximately 30 seconds after the float was depressed. If the float is depressed and the shutdown does not occur, the fuel sending unit needs to be readjusted or replaced.
- 7. Glow Plug Circuit:** The automatic glow plug control circuit can be set at 3 timed intervals: Maximum 5 seconds, 10 seconds and 60 seconds depending on the engine manufacturer's requirements. The control default is set at 10 seconds. For engines which require the shorter 5-second interval, the yellow wire will be taken to ground on the engine with the rest of the harness ground wires. For engines that require the maximum 60 sec. on time the violet wire from plug must be grounded. The glow plug circuit monitors the water temperature to determine the glow plug requirements. When the engine is cold the glow plug on time will be 5, 10 or 60 seconds as wired. When the engine is hot it will operate the glow plugs if required.
- 8. Fault Alarm (flashing red LED):** If any of the shutdown circuits have been activated, the red alarm LED will flash. Fuel level, oil level and water level should be checked. If everything checks out and fuel is replenished above the 20 percent level, the Auto/Manual switch should be set to the center OFF position to reset the controller.

Parts List
LSC100 Microprocessor Control
Parts List

Qty	Description	Part Number
1	Controller LT100 mounted on vibration isolators with triple pole toggle switch	650744
1	Temperature sender 3/8" NPT	650745
1	Engine harness	650746
3	Red LED lens	650747
1	Green LED lens	650748
1	Yellow LED lens	650749
1	ABS Plastic box	650750
1	Single pin connector for Starter	650741
1	Two pin connector for Alternator	650742
1	Three pin connector for Fuel Solenoid	650743
1	Photocell	650755
1	Timer (Optional)	352471

Wiring Schematic for Kubota LSC100 LIGHT SEQUENCE CONTROLLER with Photocell and Optional Timer

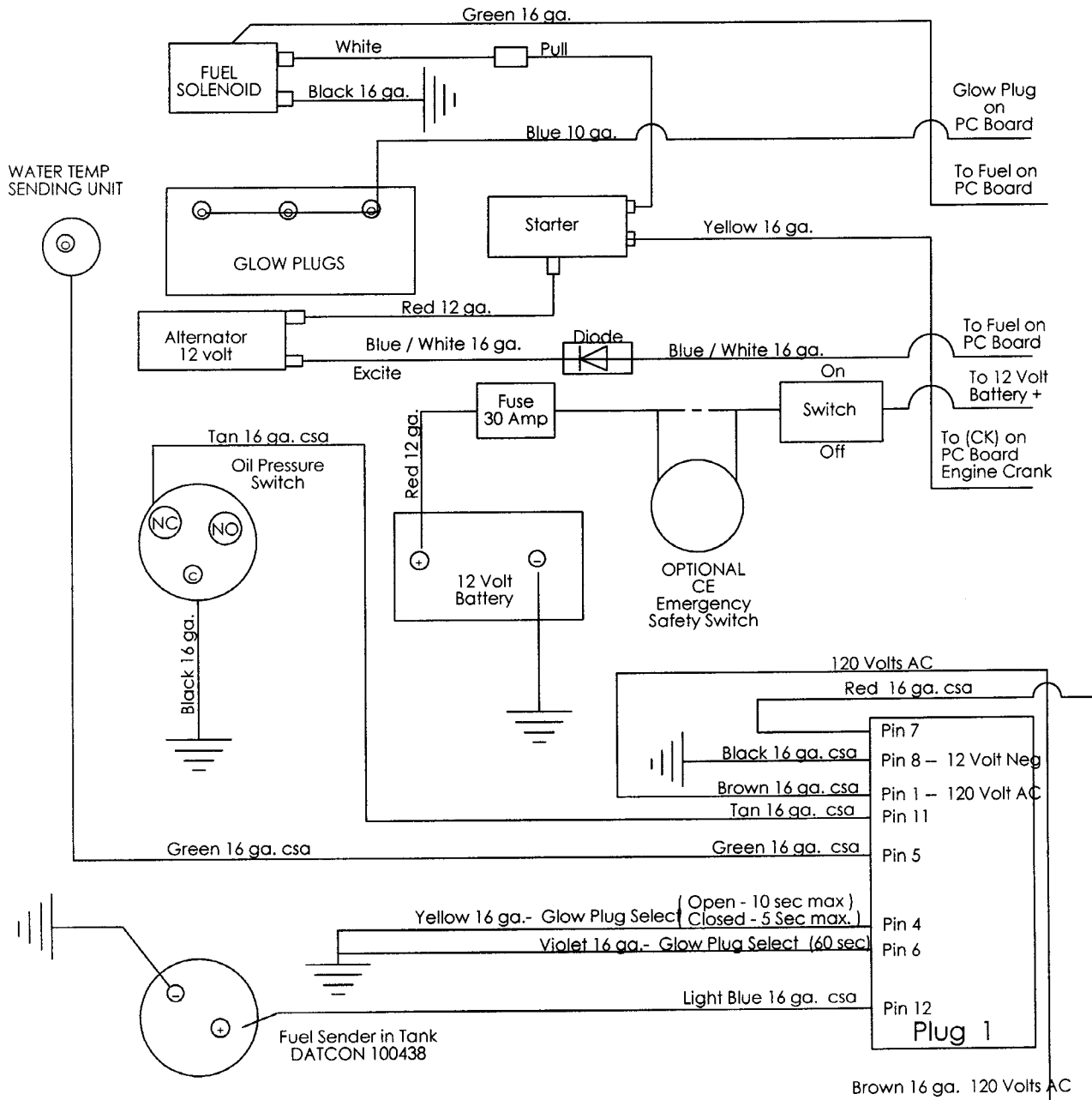

Wiring Schematic for Kubota LSC100 LIGHT SEQUENCE CONTROLLER with Photocell and Optional Timer

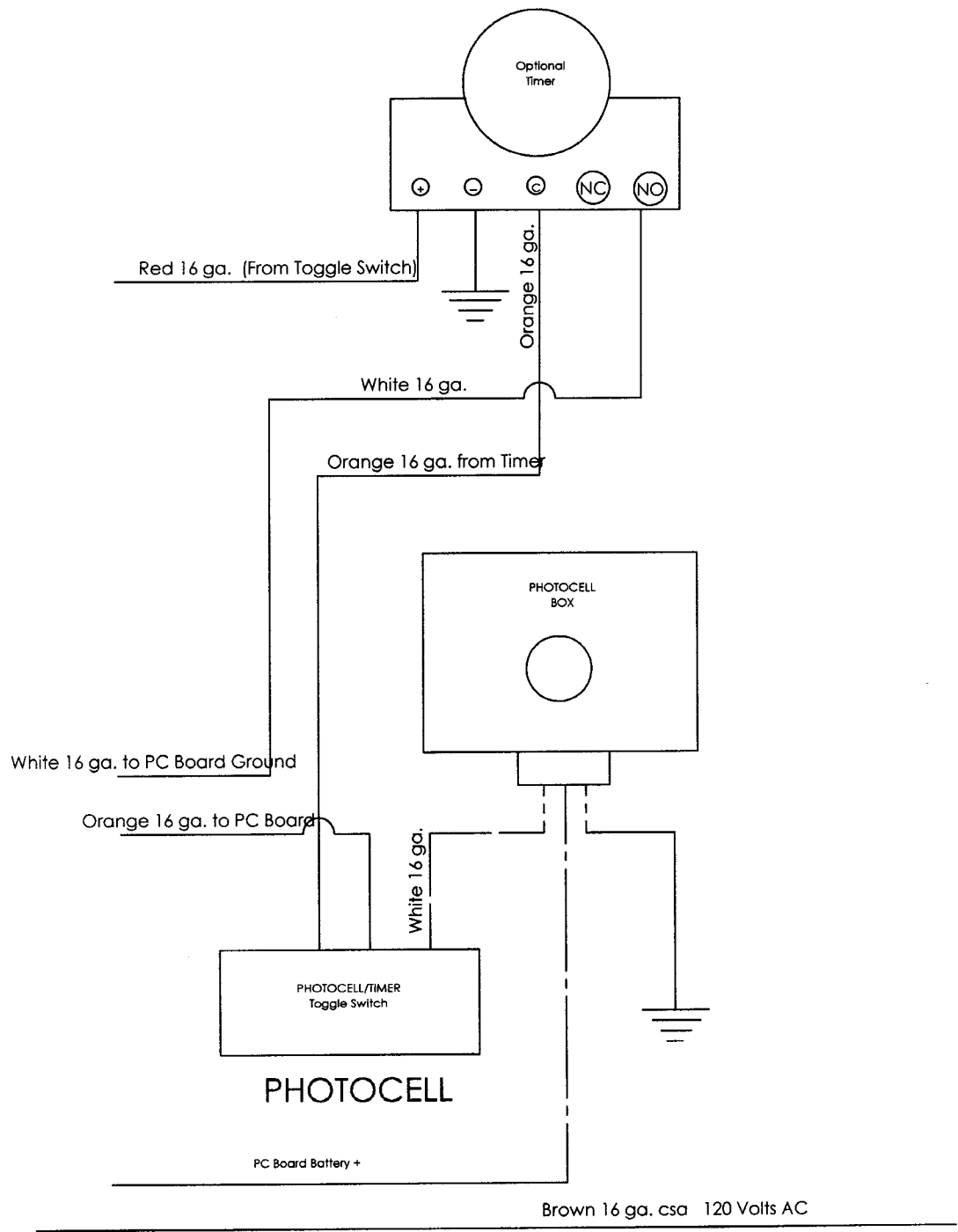

Wiring Schematic for Kubota LSC100 LIGHT SEQUENCE CONTROLLER with Photocell and Optional Timer

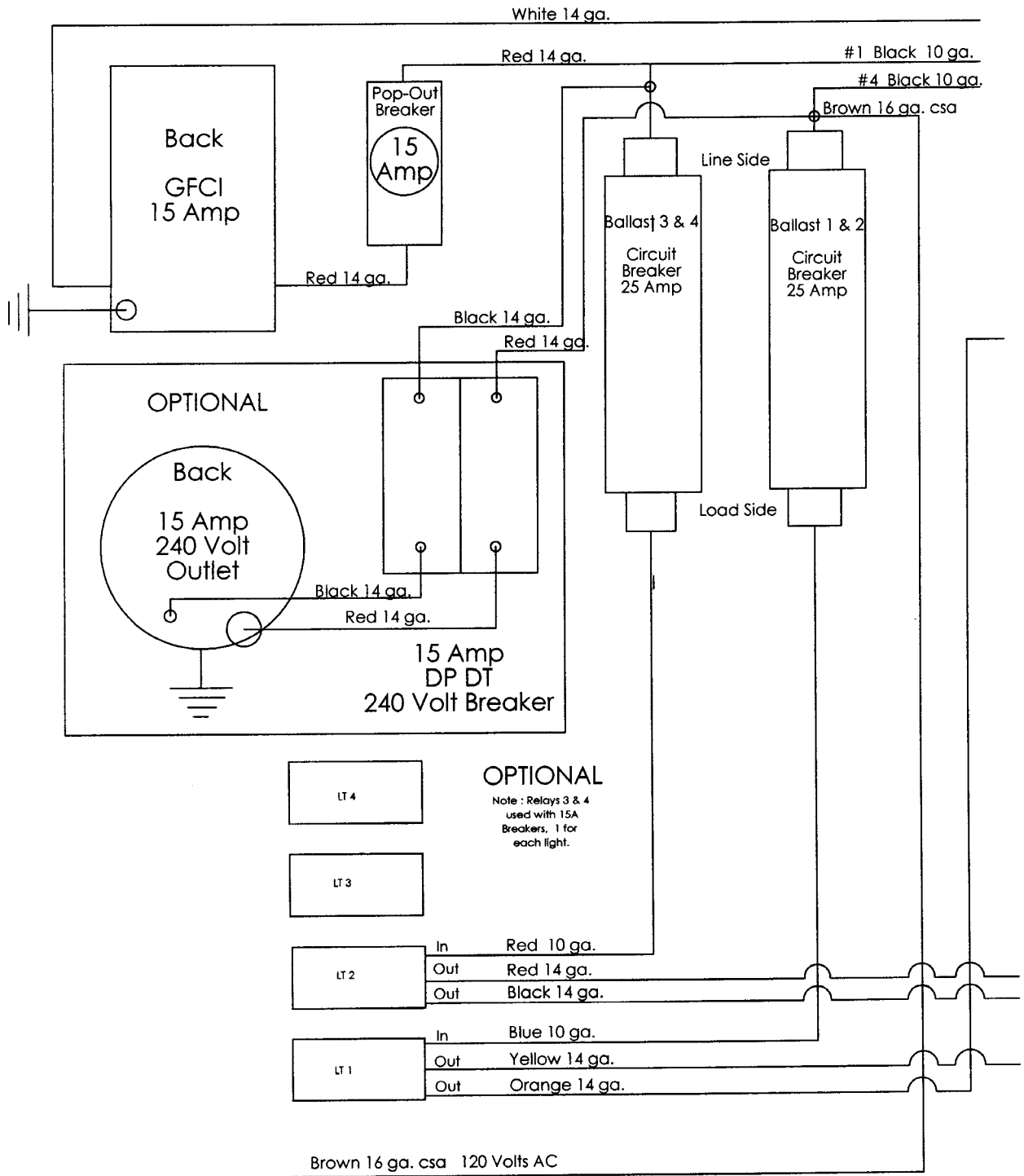

Wiring Schematic for Kubota LSC100 LIGHT SEQUENCE CONTROLLER with Photocell and Optional Timer

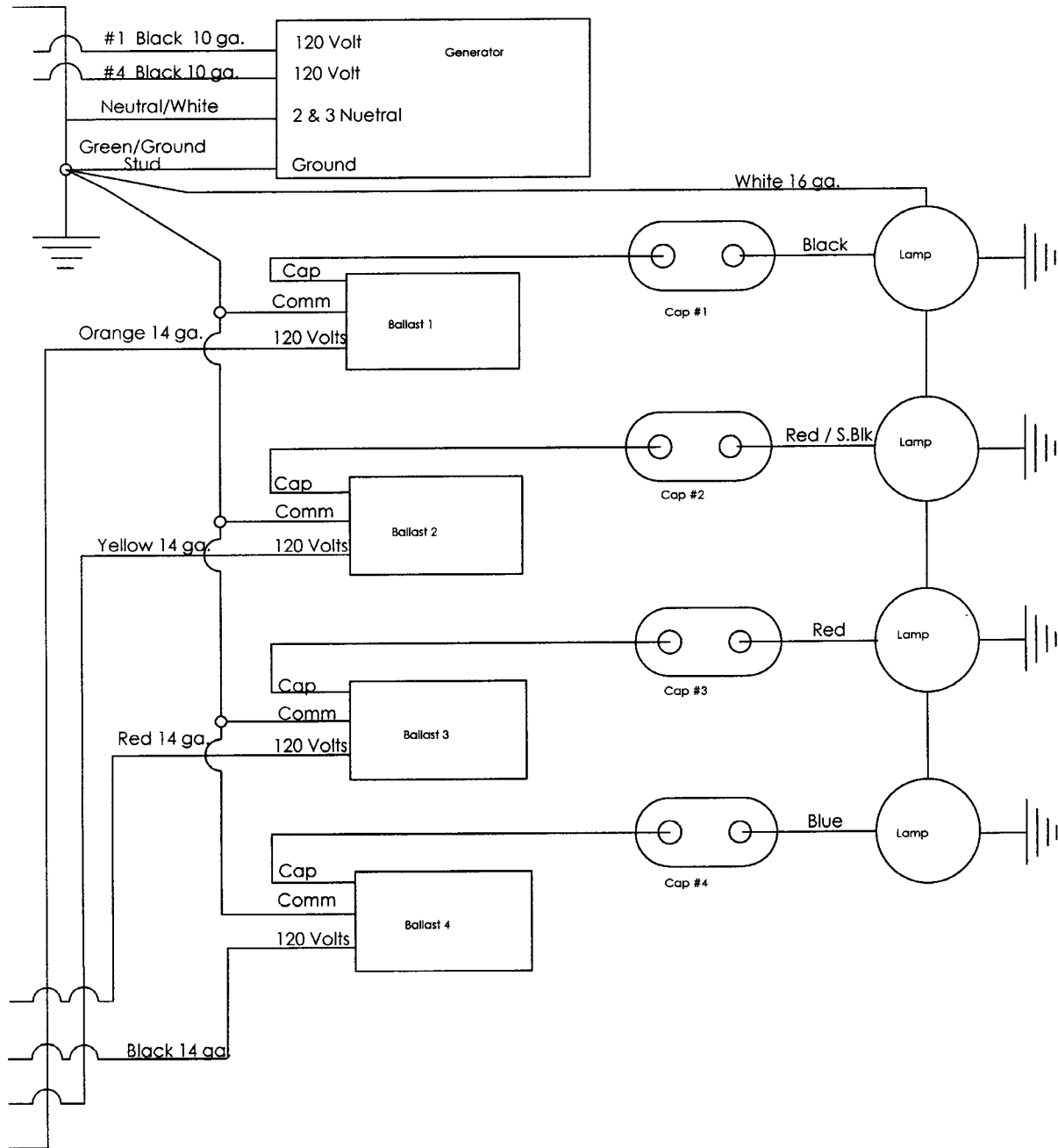

Wiring Schematic for Cat/Perkins LSC100 LIGHT SEQUENCE CONTROLLER with Photocell and Optional Timer

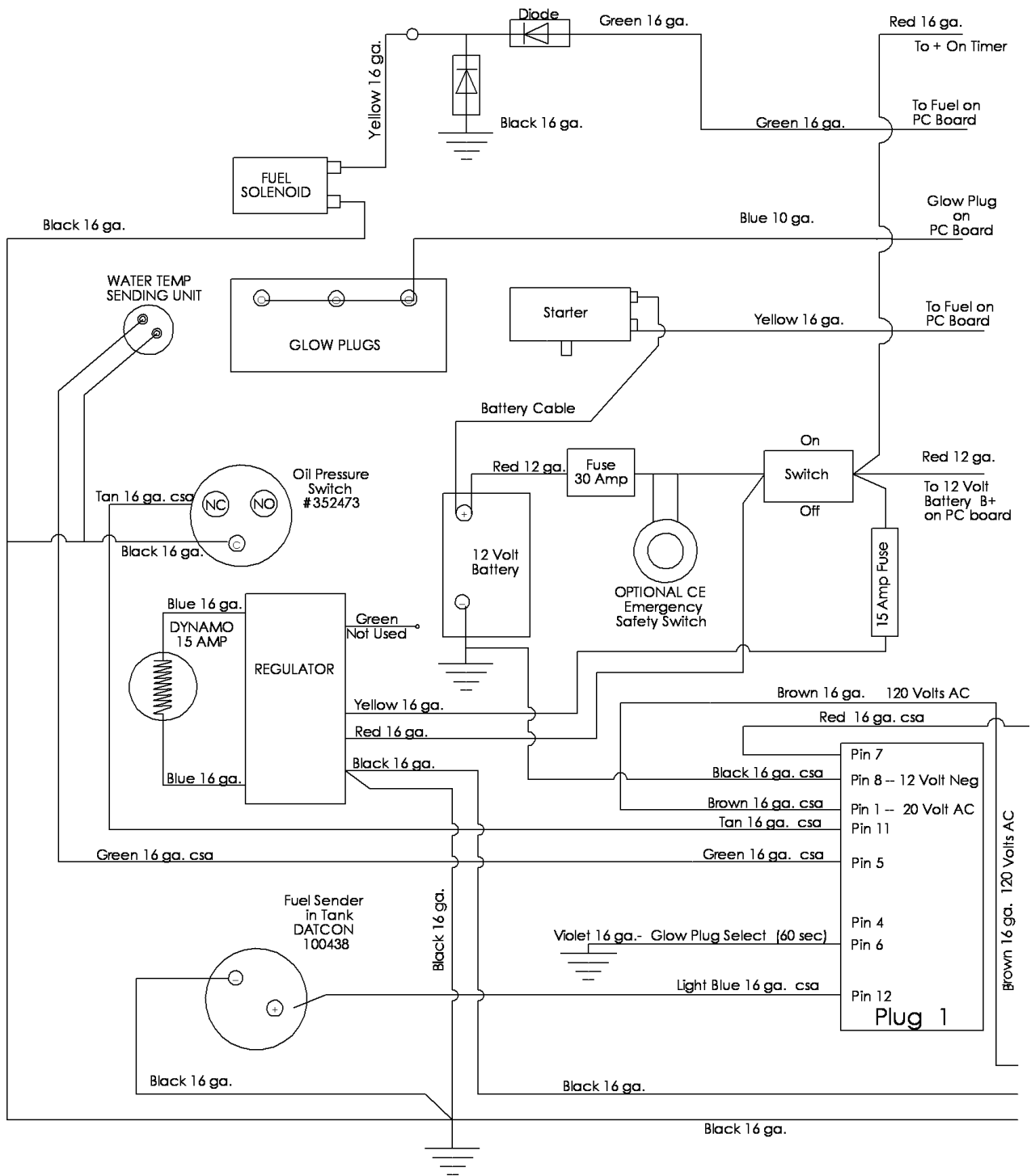

Wiring Schematic for Cat/Perkins LSC100 LIGHT SEQUENCE CONTROLLER with Photocell and Optional Timer

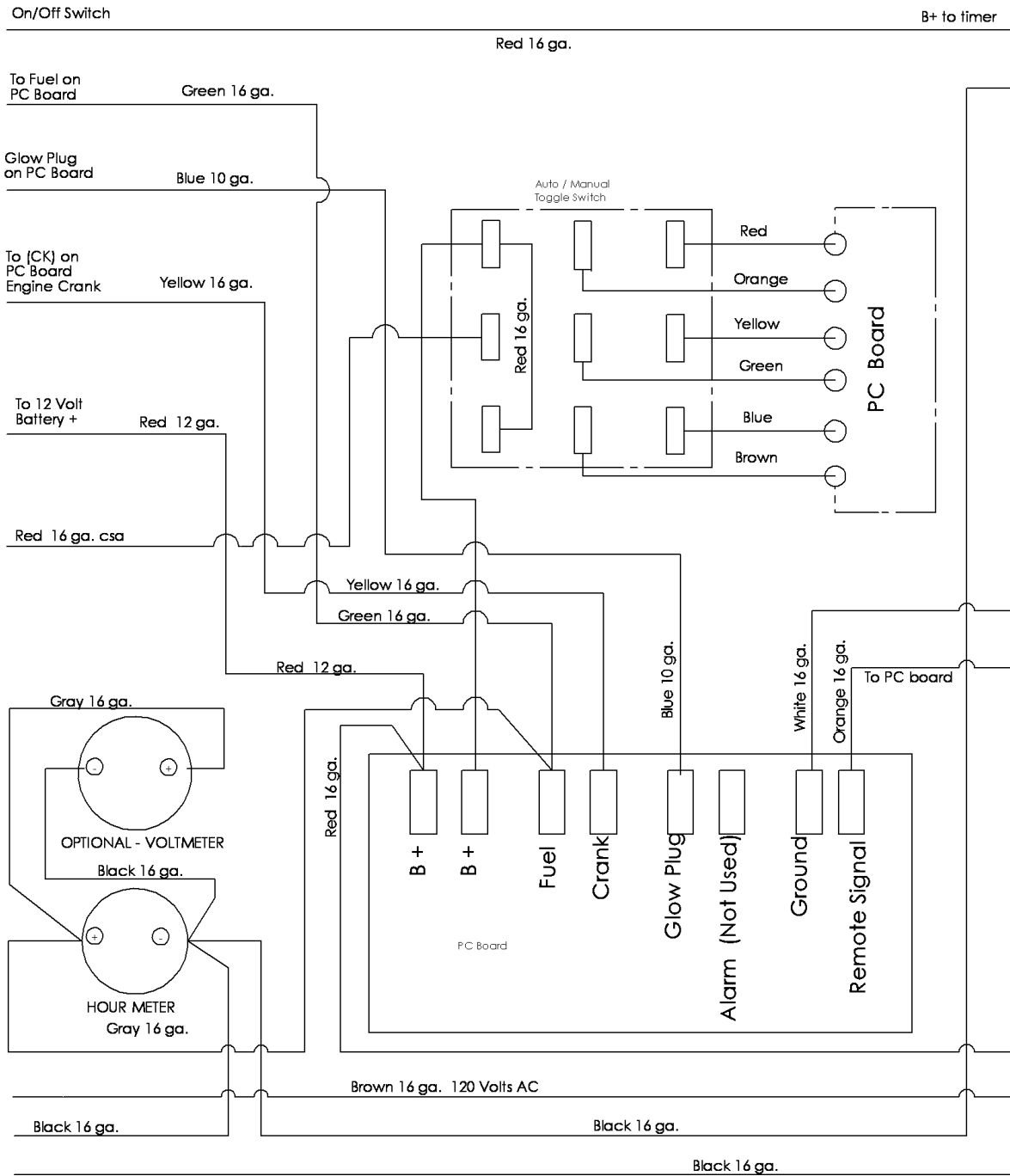

Wiring Schematic for Cat/Perkins LSC100 LIGHT SEQUENCE CONTROLLER with Photocell and Optional Timer

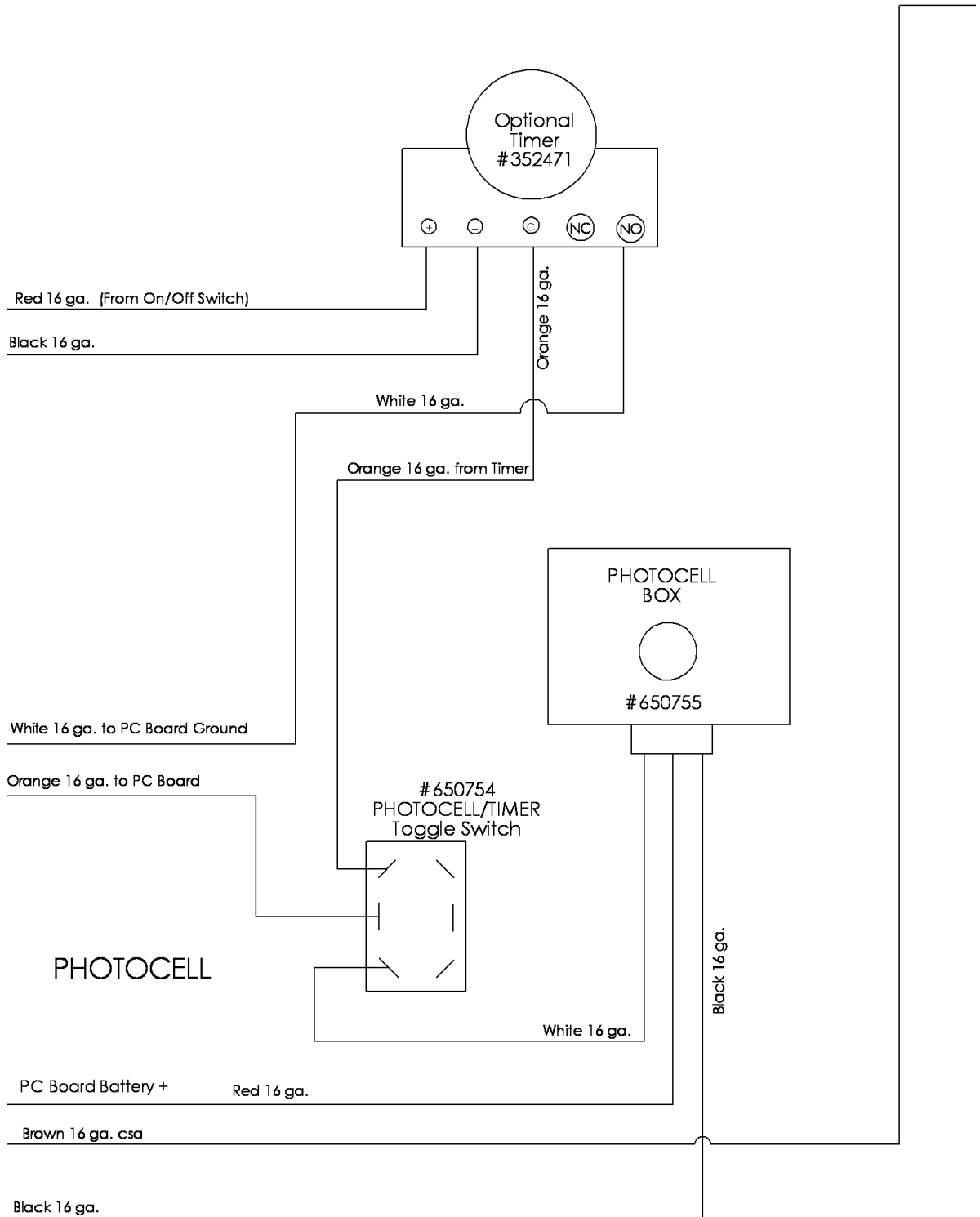

Wiring Schematic for Cat/Perkins LSC100 LIGHT SEQUENCE CONTROLLER with Photocell and Optional Timer

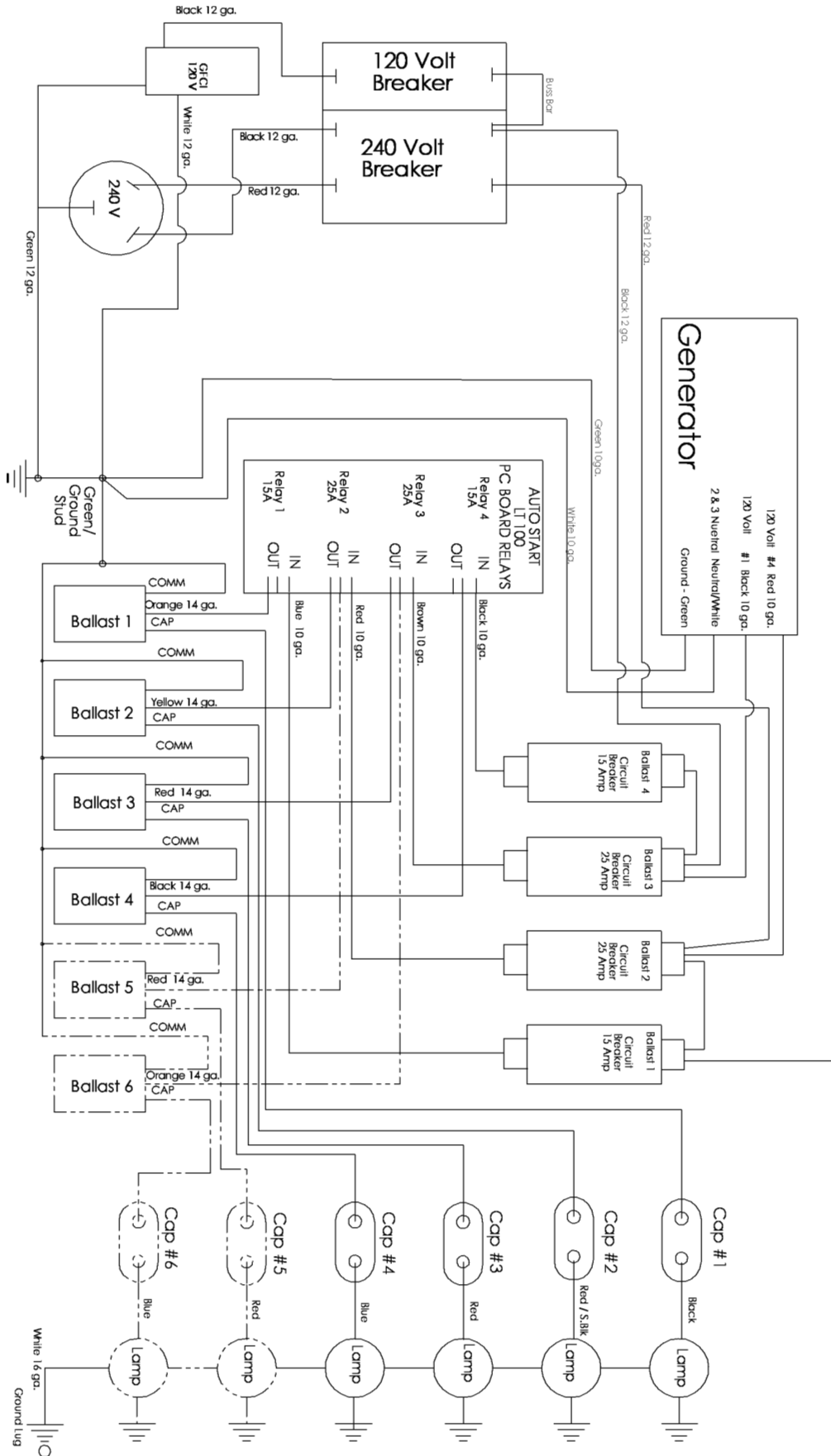

Brown 16 ga. Frequency

- 4 - LIGHT
- 2 - 25 AMP CIRCUIT BREAKERS
- 2 - 15 AMP BREAKERS
- 6 - LIGHT OPTION IN DASHED LINES

LSC100 LIGHT SEQUENCE CONTROLLER

Logic Sequence Flow Chart

