

# Allmand™

## TLB Series

### TLB 6235 ESL



TLB 220

TLB 225

TLB 325

TLB 6235 ESL

TLB 425 ESL

- Full time 4x4 drive system keeps you going in even toughest of conditions
- New loader design provides higher reach and improved dump angle
- Allmand ESL backhoe delivers exceptional performance and reduced maintenance

TLB 535 ESL

Strong Past. Dynamic Future.

Reliability, performance,  
and integrity since 1938



### SPECIFICATIONS

Engine:	Isuzu 3CD1, 33 hp, liquid-cooled diesel
Transmission:	Heavy-duty servo-controlled hydrostatic (65 hp rated)
Drive Motor:	Axial piston motor
Power Steering:	Load-sensing hydraulic steering with balanced steering cylinder
Differential:	Off-highway, planetary, limited slip
Speed Range:	0 to 7.0 mph (11.2 km/h)
Aux. Hyd.	
Output:	8 gpm @ 2,400 psi
Tires:	Front: 12 x 16.5 Rear: 14 x 17.5
Capacities:	Fuel 12 gal. (45.4 L) Hydraulic oil: 26 gal. (98.4 L)
Loader:	Single-lever joystick with bucket float Bucket Capacity: 2/3 cu. yd. (.6 cu. m) Breakout force: 3,400 lbs. (1542 kg) Lift Capacity: 2,100 lbs. (952 kg)
Brakes:	Hydrostatic service brake Spring applied/Hydraulic release brake Hand applied parking brake
Backhoe:	ESL™ design Digging force: 6,000 lbs. (2722 kg) @ bucket 2,511 lbs. (1139 kg) @ dipper Digging depth: 9 ft. 10 in. (3.0 m) 9 ft. 6 in. (3.0 m) 2 ft. flat bottom Buckets: 12 in. (30.5 cm) 16 in. (std) (40.6 cm) 18 in. (45.7 cm) 24 in. (61 cm) 36 in. (91.4 cm) 180-degree swing arc with cushioned swing cylinders Steel grouser pads Stabilizers extend to 9 in. (22.8 cm) below grade



### WORKING RANGE

- A. Maximum lift height (bucket pivot): 110 in. (2.8 m)
- B. Clearance with bucket dumped: 90 in. (2.3 m)
- C. Reach @ maximum height: 20 in. (50.8 cm)
- D. Bucket dump angle: 45 degrees
- E. Reach @ grade: 67.5 in. (1.7 m)
- F. Bucket rollback angle: 40 degrees
- G. Loader digging depth: 4 in. (10 cm)
- H. Backhoe digging depth: 9 ft. 10 in. (3.0 m)  
9 ft. 6 in. (3.0 m) 2 ft. flat bottom
- I. Straight wall digging depth: 5 ft. 4 in. (1.6 m)
- J. Digging depth (8 ft. flat bottom): 8 ft. 8 in. (2.6 m)
- K. Maximum loading height: 7 ft. 9 in. (2.4 m)
- L. Reach from swing post: 12 ft. 7 in. (3.8 m)

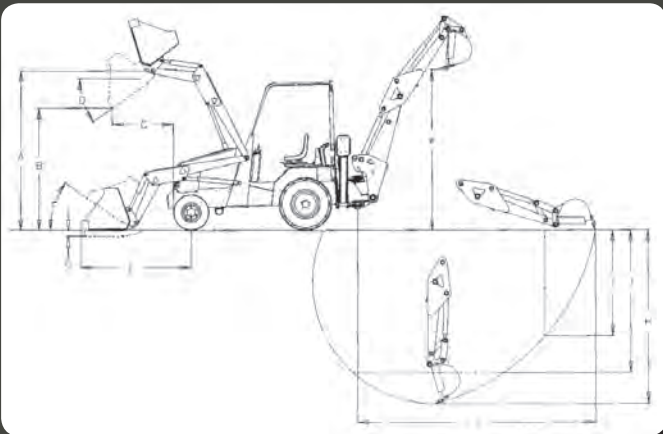

### DIMENSIONS

Length:	18 ft. 2 in. (5.5 m)
Height:	93 in. (2.4 m) ROPS
Width:	67 in. (1.7 m)
Wheelbase:	65 in. (1.7 m)
Bucket width:	70 in. (1.8 m)
Ground clearance:	11.5 in. (29.2 cm)
Transportation	
Length:	14 ft. 7 in. (4.5 m)
Weight:	5,800 lbs. (2631 kg)

