



185 CFM Towable Compressor Service Manual

Not for Reproduction



Preface

This service manual explains about the cautions for maintenance jobs and is to serve a guide for the electric system, and troubleshooting for service personnel. Fundamental matters and other things already mentioned in the “Instruction Manual” and the “Parts Catalogue” are omitted to avoid duplication. Therefore, for the operation and handling of this unit, we request you to refer to the instruction manual and caution plates, and further for the structure and components of the unit, please refer to the “Parts Catalogue” separately to be supplied with the unit.

If you should find any description which does not coincide with the instruction manual and parts catalog, we request you to make sure to start the job after clarifying it.

Service personnel is required to safely take quick and proper countermeasures as well as to use correct technology of maintenance in case of field services and periodical maintenance. It is important that service personnel should have proper and sufficient knowledge about the structure and function of the unit and should be well familiar with such technique mentioned in them.

Regarding the part numbers mentioned in this manual, we request you to refer to the Parts catalogue separately supplied together with the unit, because the parts numbers in this manual are sometimes changed.

Copies of this service manual are intended to be distributed to limited numbers of our customers. The unauthorized reproduction or distribution of this service manual is prohibited.

Table of Contents

1. Specification	1-1
1.1 Specifications	1-1
1.2 Set Value	1-2
1.3 Outline Drawing	1-3
1.4 Internal Components and Part Names	1-5
1.5 Instrument Panel	1-7
1.5.1 Indicator lamp	1-8
1.6 Capacity Control Device	1-9
1.6.1 Auto idle control (purge control)	1-10
1.6.2 Adjustment of auto idle control (purge control) and correction of engine speed	1-11
1.7 Piping Diagram	1-12
1.8 Fuel Piping	1-13
2. Maintenance	2-1
2.1 Cautions for Overhauling	2-1
2.1.1 Precautions before starting work	2-1
2.1.2 Disassembly and reassembly	2-1
2.2 Tightening Torque	2-2
2.2.1 General bolts and nuts tightening torque	2-2
2.2.2 Tightening torque of such important quality parts as bolts and nuts	2-3
2.3 How to Adjust Regulator	2-6
2.4 Change of Element in Fuel Pre-filter	2-7
2.5 Change Oil Separator	2-8
2.6 Change O-ring of Unloader	2-9
2.7 Change O-ring of Auto-relief Valve and Vacuum Relief Valve	2-11
2.8 Maintenance and Adjustment of Pressure Control Valve	2-12
2.9 Change of Pellet assembly of By-pass Valve	2-13
2.10 Air Bleeding in Fuel Line	2-14
2.11 Clean Inside of Fuel Tank	2-14
2.12 Clean Drain Separator (Option: With aftercooler only)	2-15
2.13 Values of Various Adjustments of Engine	2-15
3. Electric System	3-1
3.1 Electronic Control System of Engine	3-1
3.1.1 Electronic control system	3-1
3.1.2 Acceleration control	3-2
3.1.3 Diesel particulate filter (DPF)	3-3
3.1.4 DPF regeneration control	3-4
3.1.5 Preheating control	3-7
3.2 Emergency Controller	3-8
3.2.1 Emergency controller	3-13
3.3 Engine Controller (ECU)	3-17
3.4 Alternator	3-24
3.5 Starter	3-26
3.6 Starter / Glow Plug Relay	3-27
3.7 EGR Valve Relay	3-28
3.8 Solenoid Valve (SV1) for Starting Unloader and Purge / Solenoid Valve (SV2) for Aftercooler Drain: Option	3-29
3.9 Engine Oil Pressure Switch (for emergency stops)	3-29
3.10 Fuel Air-bleeding Electromagnetic Pump	3-30
3.11 Discharge Temperature Sensor / Water temperature Sensor	3-30

Table of Contents

3.12 Pressure Sensor (for intake negative pressure / service pressure and regulator secondary pressure) -----	3-31
3.13 Fuel Meter (Display) -----	3-31
3.14 Sending Unit -----	3-32
3.15 Air filter Differential Pressure Switch -----	3-32
3.16 Electronic Control Engine Component -----	3-33
3.16.1 Supply pump -----	3-34
3.16.2 Rail -----	3-34
3.16.3 Rail pressure sensor -----	3-34
3.16.4 Injector -----	3-35
3.16.5 Water temperature sensor (ECU) -----	3-35
3.16.6 Water temperature sensor (Gauge) -----	3-35
3.16.7 Engine oil pressure switch -----	3-35
3.16.8 Crank speed sensor -----	3-36
3.16.9 Cam speed sensor -----	3-36
3.16.10 New air temperature sensor -----	3-36
3.16.11 Intake air temperature sensor -----	3-36
3.16.12 Intake air throttles -----	3-37
3.16.13 EGR valve -----	3-38
3.16.14 EGR (Intake/Exhaust) pressure sensor -----	3-38
3.16.15 EGR gas temperature sensor -----	3-38
3.16.16 Exhaust manifold temperature sensor -----	3-39
3.16.17 Diesel particulate filter (DPF) differential pressure sensor -----	3-39
3.16.18 Diesel particulate filter (DPF) intermediate/inlet temperature sensor -----	3-40
3.16.19 Fuel temperature sensor -----	3-40
4. Troubleshooting -----	4-1
4.1 Repairing Procedures -----	4-1
4.1.1 Safety caution -----	4-1
4.1.2 Caution during failure diagnosis -----	4-1
4.1.3 How to use the failure diagnosis -----	4-2
4.2 Failures of Compressor and Engine -----	4-3
4.2.1 At start-up, starter rotates slowly -----	4-3
4.2.2 Starter turns, but engine will not start -----	4-3
4.2.3 Engine revolutions will drop before rises up to rated pressure -----	4-4
4.2.4 Engine will not turn to meet rated revolutions -----	4-5
4.2.5 Minimum speed not available even upon no-load operation -----	4-6
4.2.6 Safety valve bursts out during unloaded operation -----	4-6
4.2.7 Oil mixed found in delivery air -----	4-7
4.2.8 Water found mixed in discharge air (Aftercooler type) -----	4-7
4.2.9 Discharge air is insufficient -----	4-8
4.2.10 Purge control operation will not start even if AUTO IDLE (purge control) switch is pressed --	4-9
4.2.11 Even when the pressure at consumer's side drops, it will not recover from purge control operation -----	4-10

Table of Contents

4.3	Operation of Emergency Switch	4-11
4.3.1	Discharge temperature indication lamp glows and engine stops	4-11
4.3.2	Engine oil pressure indication lamp glows and engine stops	4-12
4.3.3	Engine water temperature indication lamp glows and engine stops	4-13
4.4	Others	4-14
4.4.1	Residual pressure lamp lights on and engine will not be able to start	4-14
4.4.2	Indicator lamps will not glow, but engine stops	4-14
4.5	Explanation of Trouble Diagnosis	4-15
4.6	Engine Trouble Diagnosis Function	4-17
4.6.1	Engine trouble diagnosis	4-17
4.6.2	List of diagnostic trouble codes (DTC)	4-21
4.6.3	Trouble diagnosis tool (SMARTASSIST-Direct)	4-23
5.	References	5-1
5.1	Consumable Parts and Electrical Appliances	5-1
5.2	Engine Wiring Diagram	5-3

Not for Reproduction

1. Specification

1.1 Specifications

Item	unit	
●Weight · Mass		
Overall length	in.(mm)	134.0(3,404)
Overall length (Bonnet only)	in.(mm)	75.2(1,910)
Overall width	in.(mm)	66.3(1,685)
Overall height	in.(mm)	61.0(1,550)
Net dry mass	lb(kg)	2,050(930)
Operating mass	lb(kg)	2,450(1,111)
●Compressor		
Free air delivery	cfm(m ³ /min)	185(5.2)
Working pressure	psi(MPa)[bar]	100(0.69)[6.9]
Pressure of pressure control valve	psi(MPa)[bar]	58(0.40)[4.0]
Burst pressure of safety valve	psi(MPa)[bar]	150(1.03)[10.3]
Ambient conditions: temperature	°F(°C)	5 to 104(-15 to +40)
Ambient conditions: altitude	yd(m)	Less than 1,640(1,500)
●Engine		
Type		YANMAR 4TNV88C-DHKS
Rated output (Gross)	hp/min ⁻¹ (kW/min ⁻¹)	47.6/3,000(35.5/3,000)
Rated output (Net)	hp/min ⁻¹ (kW/min ⁻¹)	45.6/3,000(34.0/3,000)
Fuel consumption	g/kW·h	248
Rated RPM	min ⁻¹	3,000
RPM at unload conditions	min ⁻¹	1,350
Net dry mass	lb(kg)	441(200)
●Lubricating oils		
Engine oil capacity (H/L level)	gal.(L)	1.95/0.90(7.4/3.4)
Compressor oil capacity (including receiver tank and oil cooler etc.)	gal.(L)	3.59(13.6)
Compressor oil capacity to be filled		Ambient temperature: 5°F to 104°F (-15°C to +40°C)
		HULS : ANDEROL 3032 MOBIL : RARUS SHC 1024 TEXACO: SYN-STAR DE32
Coolant capacity	gal.(L)	1.80(6.8)
Fuel tank capacity	gal.(L)	23.8(90)
●Fuel consumption ratio (for reference only)		
At purge operation	gal./Hr(L/Hr)	0.40(1.5)
At no load	gal./Hr(L/Hr)	0.74(2.8)
At 50%	gal./Hr(L/Hr)	1.29(4.9)
At 70%	gal./Hr(L/Hr)	1.64(6.2)
At full load	gal./Hr(L/Hr)	2.38(9.0)

1. Specification

1.2 Set Value

Item	unit	
●Emergency stop devices		
Actuating temperature of discharge temperature switch	°F(°C)	248(120)
Actuating temperature of water temperature switch	°F(°C)	230(110)
Actuating pressure of oil pressure switch	psi(MPa)[bar]	7.1(0.049)[0.49]
●Warning devices		
Actuating temperature of discharge temperature switch	°F(°C)	239(115)
Actuating temperature of water temperature switch	°F(°C)	221(105)
Battery failure		When not charged
Actuating pressure of air filter indicator	psi(kPa)[bar]	0.9(6.23)[0.0623]
●Set value		
Pressure control valve	psi(MPa)[bar]	58(0.40)[4.0]
Actuating pressure of safety valve	psi(MPa)[bar]	150(1.03)[10.3]
Unload starting pressure	psi(MPa)[bar]	100(0.69)[6.9]
Time for starting purge mode operation (At AUTO IDLE operation mode)	sec	5 to 60 (Set at 10 sec. ex. works)
●Engine RPM		
Rated RPM	min ⁻¹	3,000
RPM at unload	min ⁻¹	1,350
●Indications of gauges or instruments during operation		
Discharge pressure gauge (at full load)	psi(MPa)[bar]	58 to 100(0.40 to 0.69)[4.0 to 6.9]
Discharge pressure gauge (at no load)	psi(MPa)[bar]	104 to 131(0.72 to 0.90)[7.2 to 9.0]
Discharge pressure gauge (at purge operation)	psi(MPa)[bar]	39 to 73(0.27 to 0.50)[2.7 to 5.0]

1. Specification

1.3 Outline Drawing

Unit : in.

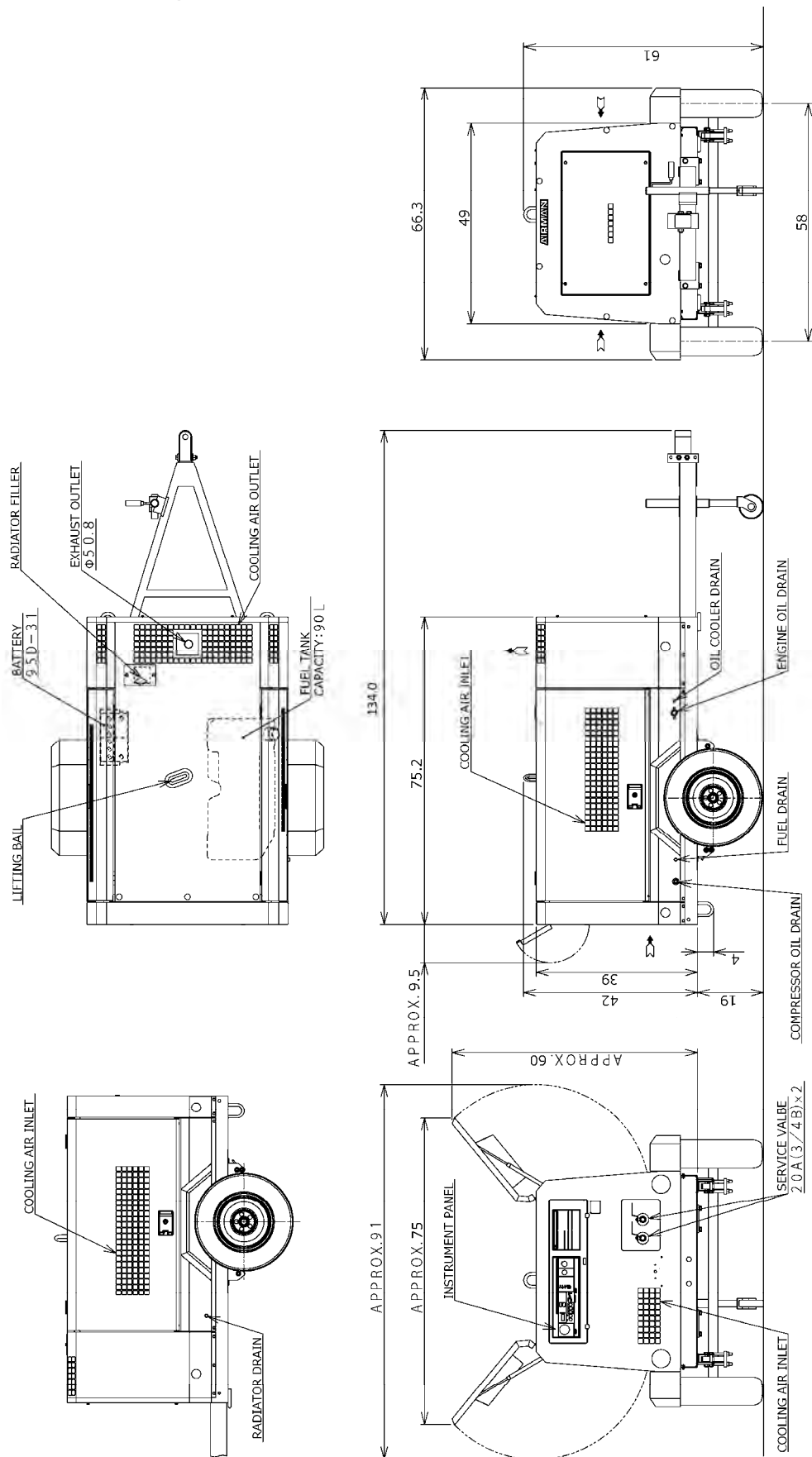

A131026

1. Specification

Unit : mm

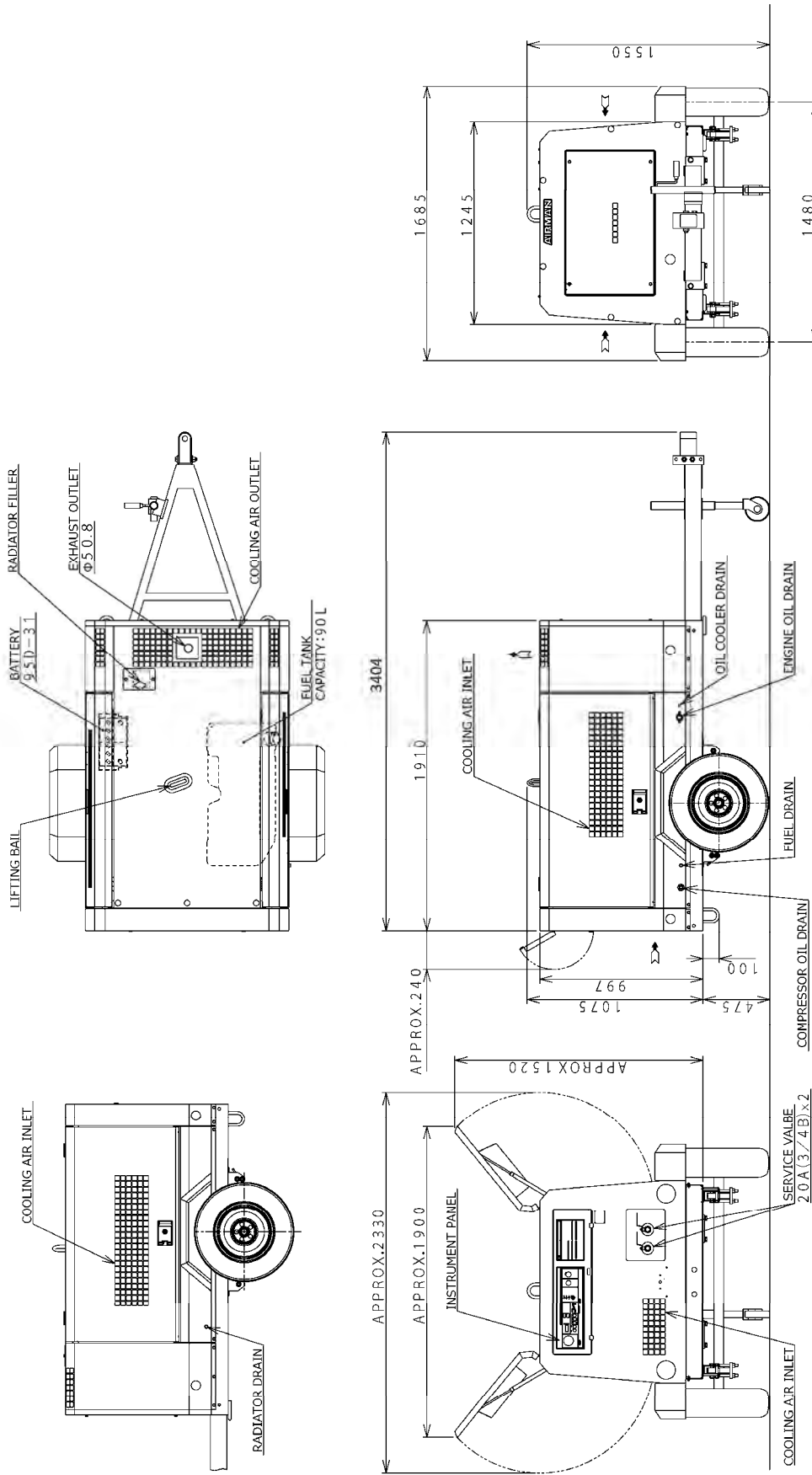

A131025

1. Specification

1.4 Internal Components and Part Names

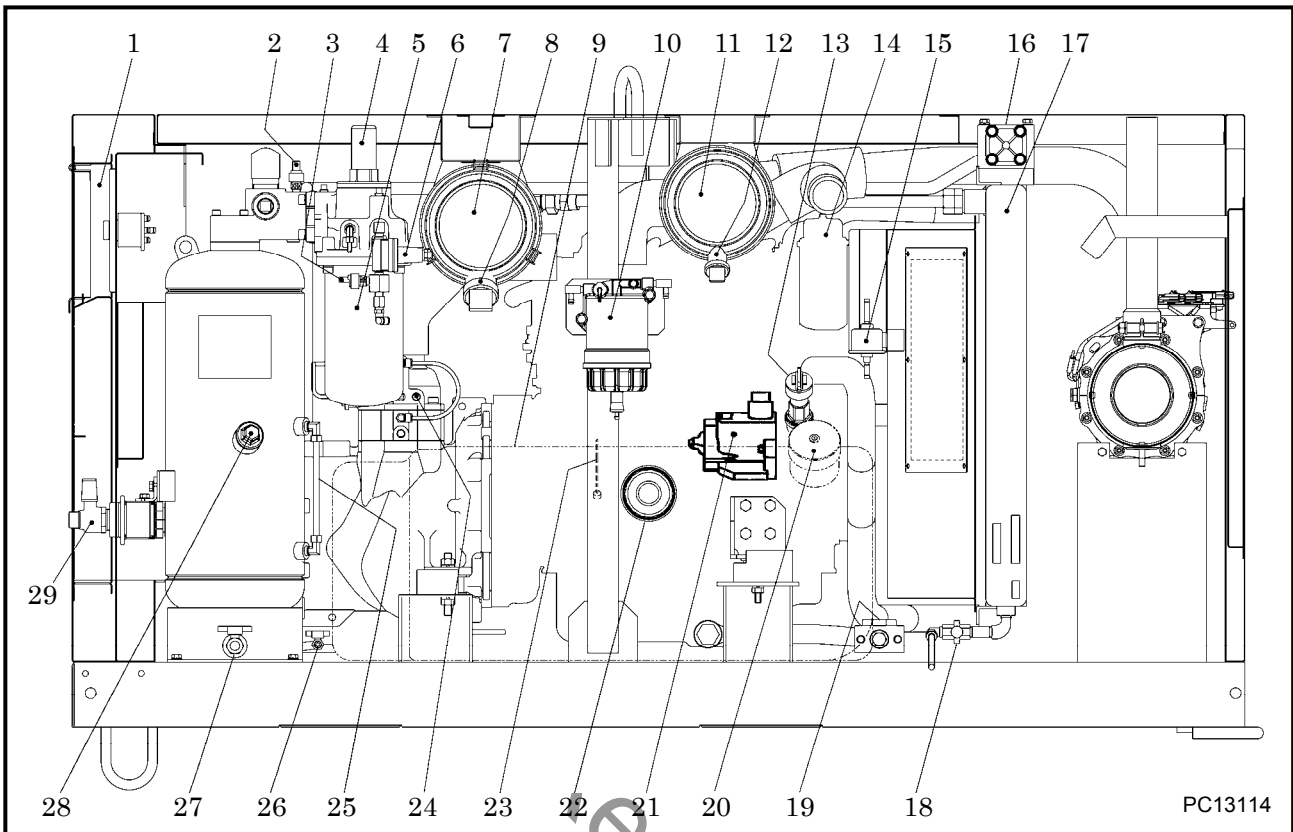

No.	Description	No.	Description
1	Instrument panel	16	By-pass valve
2	Service pressure sensor	17	Oil cooler
3	Regulator secondary pressure	18	Oil cooler drain valve
4	Pressure control valve	19	Engine oil drain valve
5	Oil separator	20	Fuel cap
6	Pressure regulator	21	Supply pump
7	Air filter (For compressor air-end)	22	Engine oil filter
8	Vacuator valve (For compressor air-end)	23	Engine oil level gauge
9	Fuel tank	24	Intake negative pressure sensor
10	Sedimenter and pre-filter	25	Compressor oil level gauge
11	Air filter (For engine)	26	Fuel tank drain valve
12	Vacuator valve (For engine)	27	Separator receiver tank drain valve
13	Engine oil filler port	28	Compressor oil filler port
14	Fuel filter	29	Service valve
15	Air-bleeding electromagnetic pump		

1. Specification

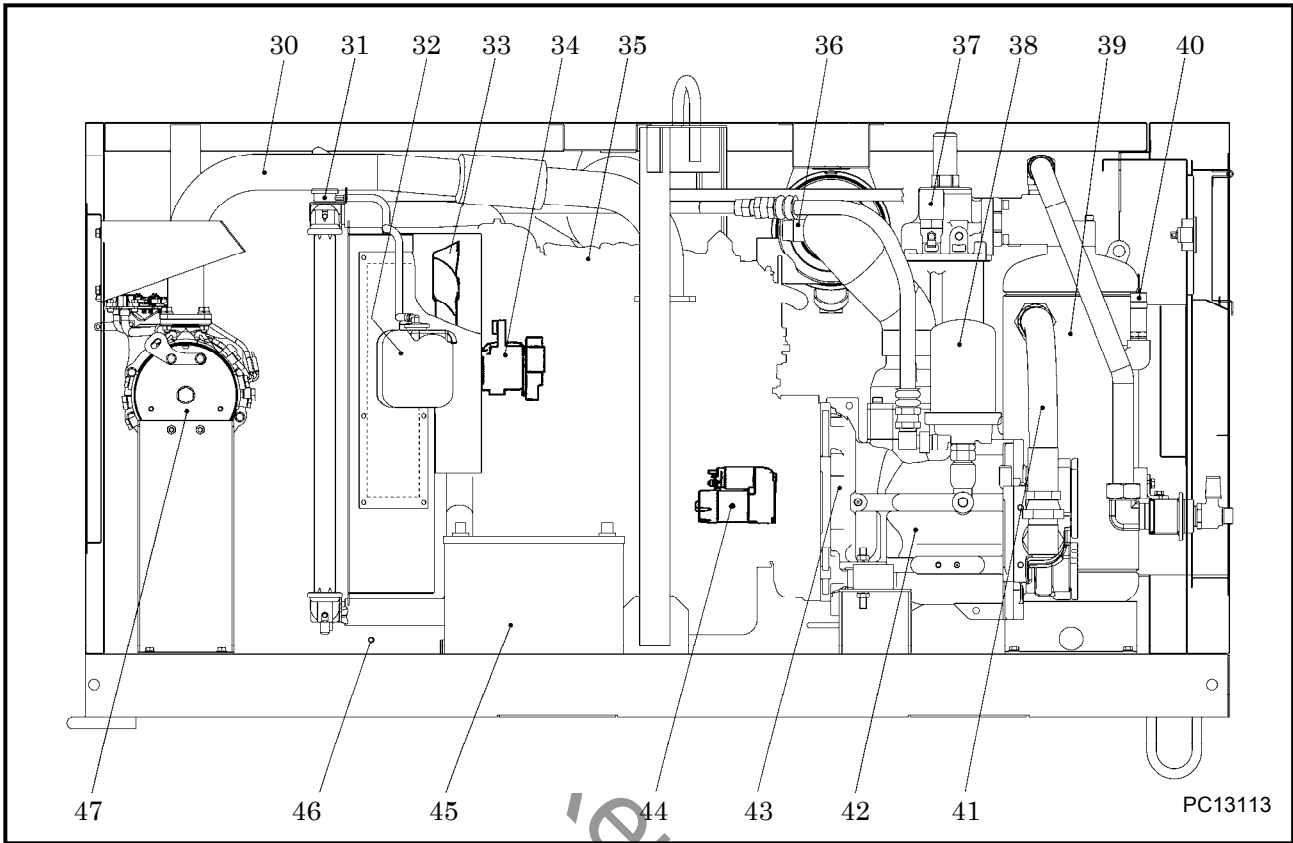

No.	Description	No.	Description
30	Exhaust pipe	39	Separator receiver tank
31	Radiator	40	Safety valve
32	Reserve tank	41	Discharge pipe
33	Cooling fan	42	Air-end
34	Alternator	43	Coupling
35	Engine	44	Starter
36	Air filter differential pressure indicator (For compressor air-end)	45	Battery
37	Solenoid valve for starting unloader (purge)	46	Radiator drain valve
38	Compressor oil filter	47	Diesel particulate filter (DPF)

1. Specification

1.5 Instrument Panel

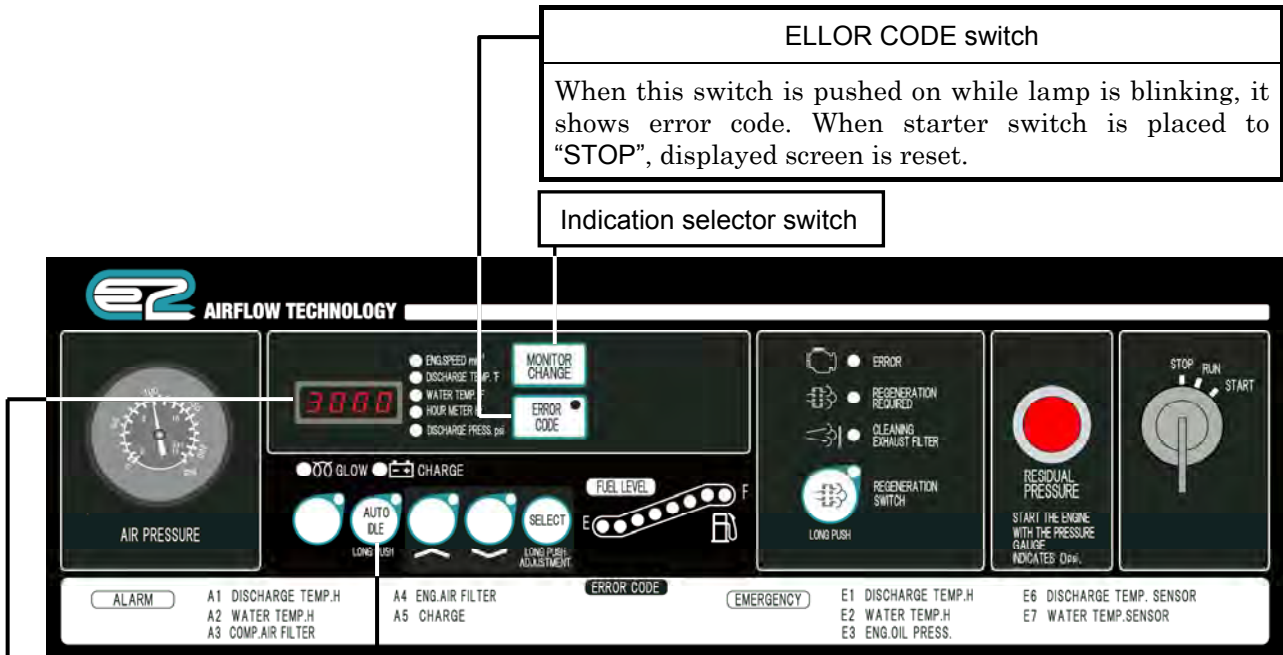

ELLOR CODE switch
When this switch is pushed on while lamp is blinking, it shows error code. When starter switch is placed to "STOP", displayed screen is reset.

Indication selector switch

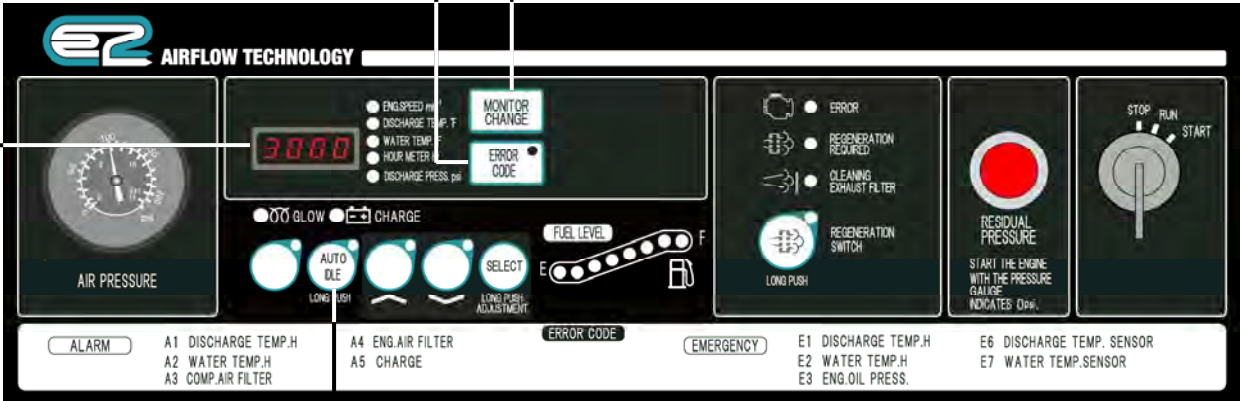

A130957

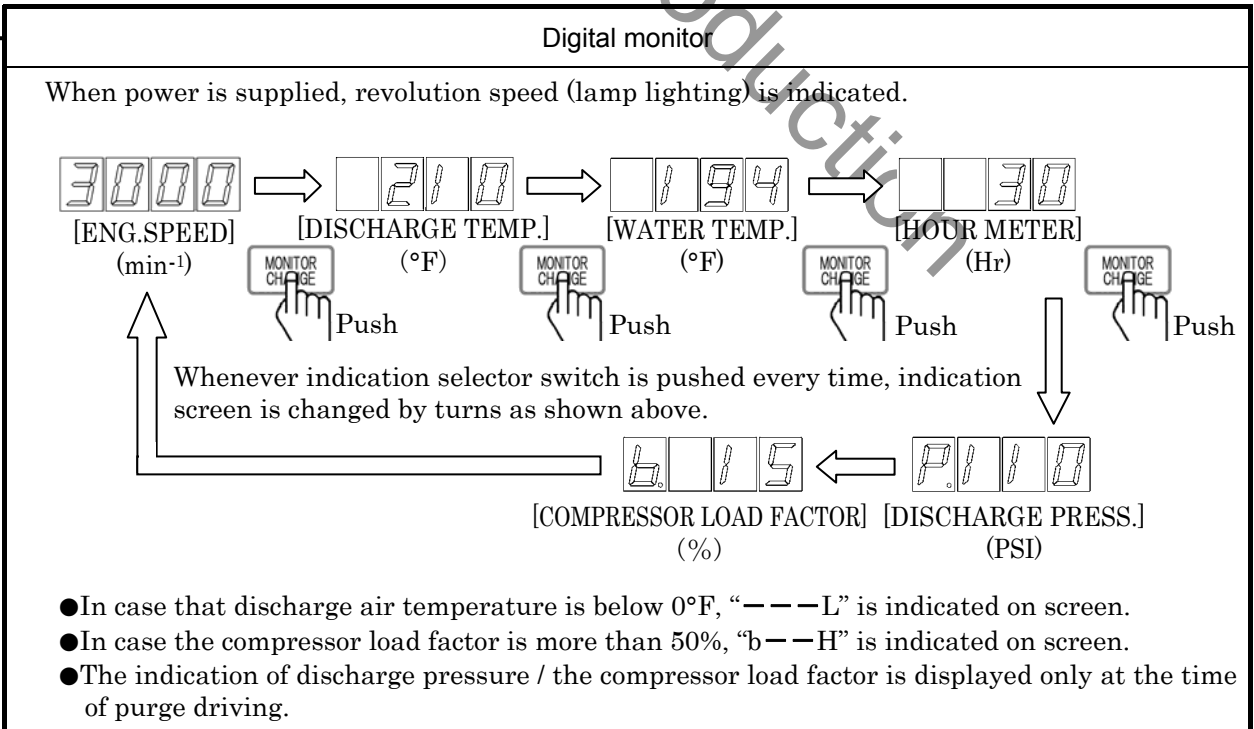

AUTO IDLE switch
This switch is used when fuel consumption is minimized at no load operation. (It functions when the lamp goes on.)



1. Specification

1.5.1 Indicator lamp

[Indicator lamp] Turn the starter switch to “RUN” position. Then the lamp goes on.

Item	Contents	Measures	Monitor
GLOW	When starter switch is placed to “RUN”, the lamp goes on and after preheating is finished, the lamp will be off.	—	
CHARGE	Lamp goes on when alternator is not charging.	Check wiring Check alternator	

[Warning display] This displays such trouble of less importance when it occurs during operation, but the unit continues operating.

When any abnormality happens, a ERROR CODE lamp flickers. In this time when ERROR CODE switch is pressed, a error code will be displayed.

Item	Error code	Contents
DISCHARGE TEMP. H	A1	Lamp flickers when the air temperature at the outlet of the air-end reaches 239°F (115°C).
WATER TEMP. H	A2	Lamp flickers when coolant temperature reaches 221°F (105°C).
COMP. AIR FILTER	A3	It is displays when air filter gets clogged and suction resistance increases. [Operating resistance: More than 0.062bar(6.23kPa)]
ENG. AIR FILTER	A4	
CHARGE	A5	Belt loosened and/or cut Faulty generation of alternator

[Emergency display] When any trouble takes place during operation, this displays and it stops as an emergency stop.

When any abnormality happens, a ERROR CODE lamp flickers. In this time when ERROR CODE switch is pressed, a error code will be displayed.

Item	Error code	Contents
DISCHARGE TEMP. H	E1	It is displays when the air temperature at the outlet of the air-end reaches 248°F (120°C).
WATER TEMP. H	E2	It is displays when coolant temperature reaches 230°F (110°C).
ENG. OIL PRESS.	E3	It is displays when engine oil pressure drops. 【Function pressure: 7.1psi(0.049MPa)[0.49bar]】
DISCHARGE TEMP. SENSOR	E6	It is displayed when air temperature sensor at the outlet port of compressor air-end is disconnected.
WATER TEMP. SENSOR	E7	It is displayed when engine water temperature sensor is disconnected.

1. Specification

1.6 Capacity Control Device

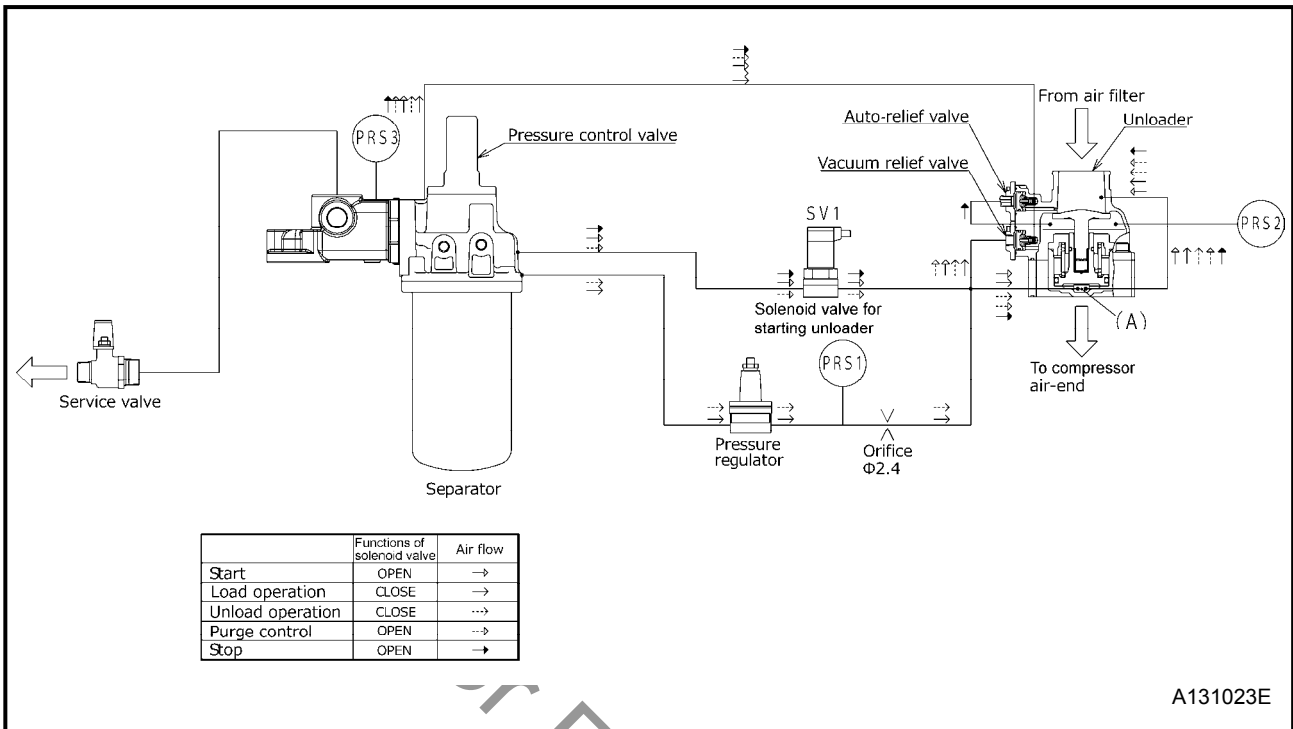

Step	Response
Start	Compressed air flows into unloader chamber (A) because solenoid valve for purge control SV1 is opened at start-up. The pressure in chamber (A) rises soon to close unloader valve fully and accordingly it can reduce the load at start-up.
Load operation	After starting, SV1 is closed after automatic unloaded operation, and the air volume which is sent to chamber (A) increases and decreases according to the rise and drop of the discharge air pressure and consequently the opening width of the unloader valve is changed. Further, engine speed (RPM) is changed by the pressure which PRS1 detects, and it steplessly controls the air volume in the range from 0 to 100%.
Suction port closing unload operation	When compressed air pressure exceeds the rated pressure with reduction of air consumption, PRS1 detects the pressure and it reduces engine speed (RPM) in proportion to the pressure rise, and it closes unloader valve at the same time. When compressor air-end becomes vacuum during unload operation, vacuum noise is caused. To prevent this noise, it opens vacuum relief valve by detection of secondary pressure of pressure regulator. Thus high vacuum condition of compressor air-end is prevented.
Purge control unload operation	When the certain set time (it can be changed.) has passed at lower pressure than the set negative pressure, detecting the negative pressure inside the compressor air-end with a pressure sensor PRS2, solenoid valve SV1 opens and it closes unloader valve. At the same time, it functions to relieve the compressed air from separator receiver tank to the atmosphere and thus it lowers the pressure. Thus the compressor power is saved. When air consumption increases, and the pressure used for load drops below the set pressure, pressure sensor PRS3 detects it and it disengages the purge control (SV1 closes) to start full load operation.
Stop	When stopping operation, it opens auto-relief valve to relieve the compressed air in separator receiver tank to atmosphere, detecting the pressure inside compressor air-end.

1. Specification

1.6.1 Auto idle control (purge control)

This model is equipped with auto idle control operation mode. This operation mode is recommendable for such use: not so much air consumption is required and it is used continuously and also power consumption under unloaded operation is required to be saved. Use this mode, depending upon the need and demand. For the selection of this mode, switch on “AUTO IDLE” on the operation panel. Select this operation mode freely, according to required air consumption.

<Procedure>

- ① During operation, long push (2 seconds) on AUTO IDLE switch (purge control) “1”.
- ② Then the AUTO IDLE lamp “2” goes on.
- ③ In order to stop this operation mode, push again AUTO IDLE switch “1” and then the lamp “2” goes out to disengage this purge control.

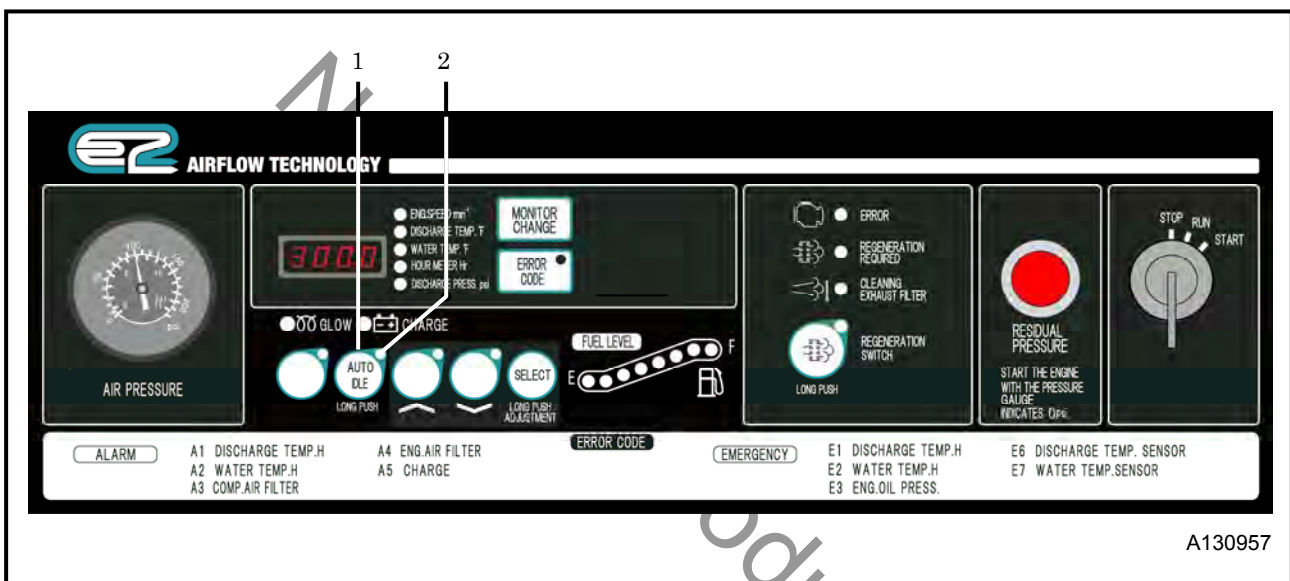

Function of auto idle control (purge control)

Function	Conditions of AUTO IDLE lamp
① First engine speed drops to the minimum speed by pressure regulator, owing to reduction of air consumption. Later the air consumption is reduced further, the unloader valve gradually closes and intake negative pressure increases. In this stage, the pressure sensor detects the intake negative pressure. Then when the intake negative pressure becomes higher than the set pressure, the AUTO IDLE lamp flickers at short intervals.	Lamp flickers at short intervals.
② When this condition continues for a certain time, the solenoid valve functions to start purge mode operation. Consequently, the pressure inside separator receiver tank drops and reduces the power of compressor air-end. In this stage, the AUTO IDLE lamp flickers at longer intervals.	Lamp flickers at longer intervals.
③ Next, when the pressure for load down to the purge releasing pressure owing to the increase of air consumption, the solenoid valve operation gets “OFF” and it is transferred to normal operation. In this stage, the AUTO IDLE lamp goes on.	Lamp goes on.

1. Specification

1.6.2 Adjustment of auto idle control (purge control) and correction of engine speed

No.	Item	Indication	Unit	Primary set value	Range of set values
1	Purge releasing pressure	P	PSI	86	70 to 100
2	Waiting time for transfer to purge mode operation	T	sec	10	5 to 60
3	Load factor for transfer to purge mode operation	b	%	15	5 to 30
4	The high-speed side correction (Full load rotational speed)	H	min ⁻¹	100	0 to 200
5	The low-speed side correction (Unload rotational speed)	L	min ⁻¹	100	0 to 200

<Procedures of adjustment>

When SELECT switch is pressed longer (than 5 seconds), first P. (Purge releasing pressure) is displayed. Each time SELECT switch is pressed, each indication will be selected. Then each time it is pressed one time, T. (Waiting time for transfer to purge mode operation) is switched to b. (Load factor for transfer to purge mode operation) to H. (Full load rotational speed) to L. (Unload rotational speed), according to the set orders.

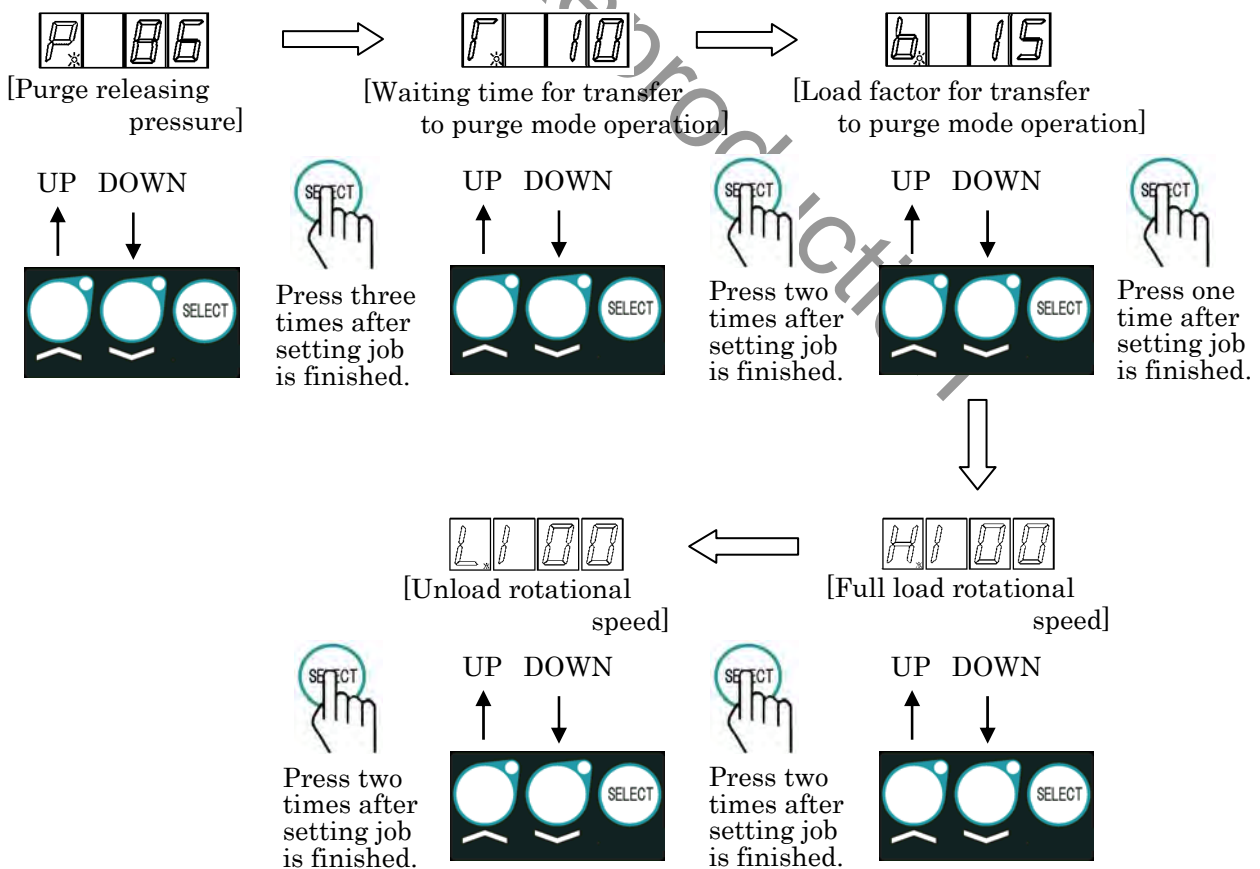

1. Specification

1.7 Piping Diagram

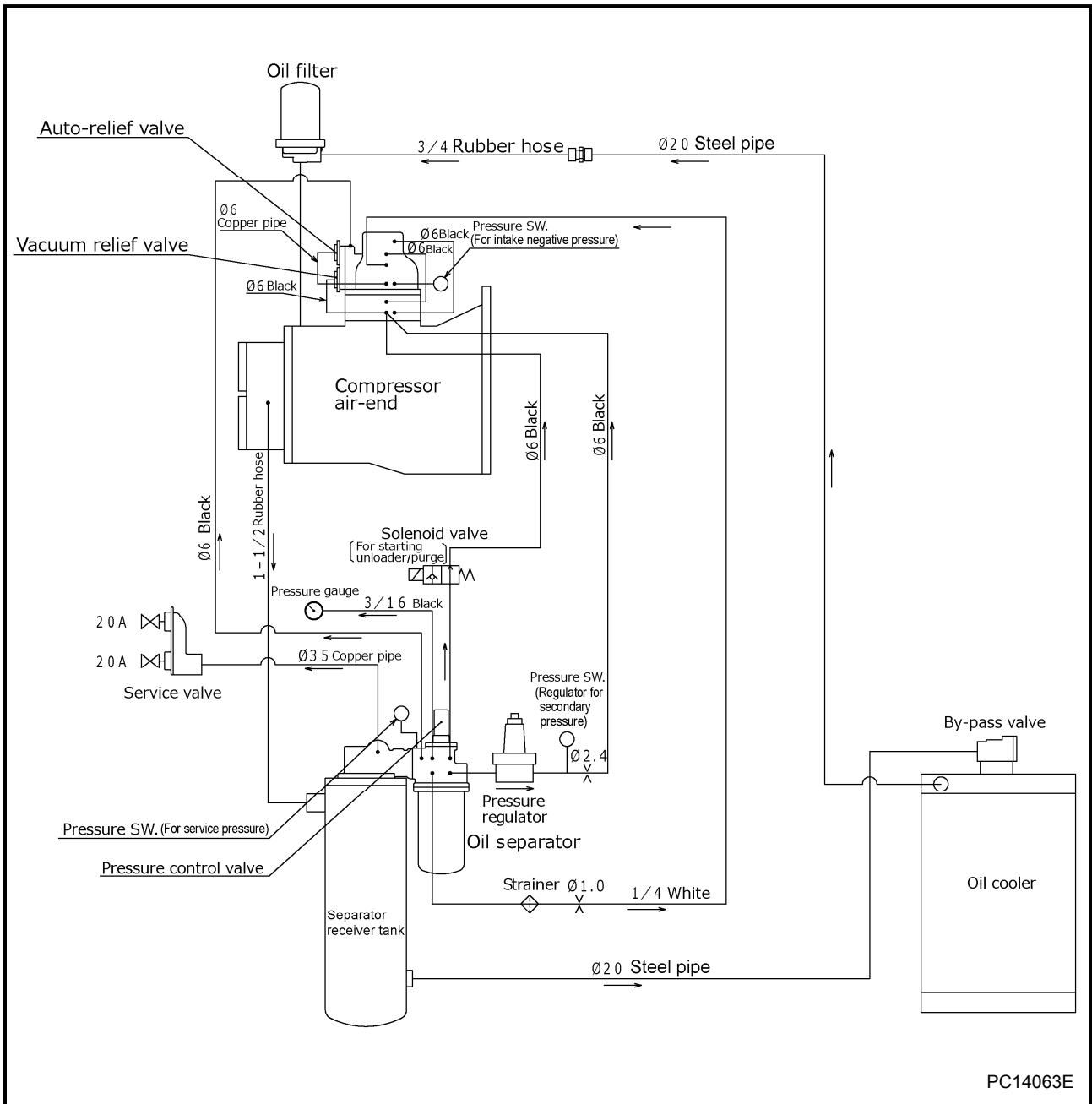

1. Specification

1.8 Fuel Piping

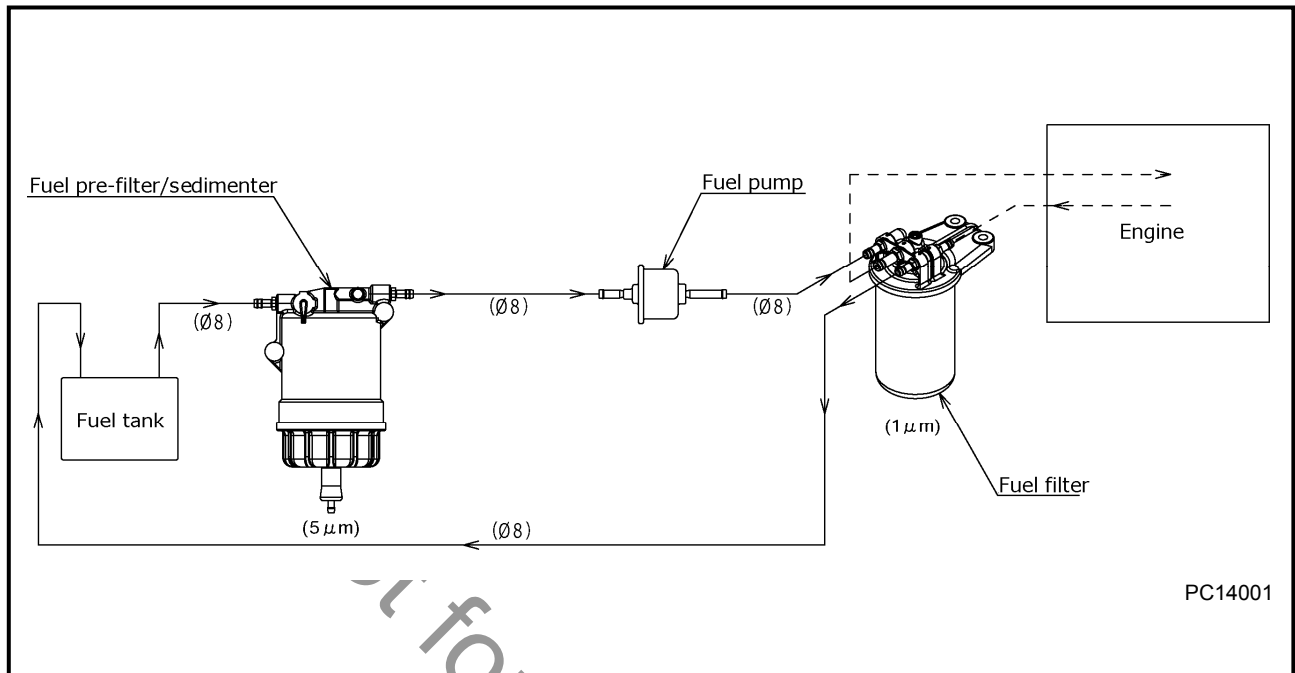

2. Maintenance

2.1 Cautions for Overhauling

2.1.1 Precautions before starting work

(1) Work to be performed

It is very important to always plan in advance what facilities, tools, instruments, materials, oil, etc. you will need to use; the exact locations and methods of performing inspection, adjustment, or disassembly; and the key points of any repair work to be performed.

(2) Care not to spill oil

Use a pan to collect used compressor oil, engine oil when changing the oil or attaching or detaching an oil line. If a large volume of oil is expected to flow out, make sure to drain any accumulated oil from the reserve tank, engine oil pan in advance.

[Follow the designated regulations to dispose of compressor oil and engine oil.]

(3) Care when detaching parts

When disassembling a complicated part, put a matching mark to indicate the position of detached parts for future reference. Make sure that the negative – cable is detached from the battery terminals before starting repair work.

(4) Use genuine parts

Make sure to use genuine parts when changing parts. Otherwise, it degrades performance and it shortens machine life.

(5) Tools to be prepared

- | | |
|---|---|
| ① Measuring instruments
(e. g. tester, insulation resistance gauge etc.) | ⑦ Lithium based all-purpose grease
• CALTEX MULTIFAK EP1 |
| ② Tools | ⑧ Diesel oil |
| ③ Torque wrenches | ⑨ Compressor oil |
| ④ Jigs and specialized tools | ⑩ Cleaning cloths |
| ⑤ Sealing tape | ⑪ Literatures (such as manuals etc.) |
| ⑥ Molybdenum sulfide (tube type) | |

2.1.2 Disassembly and reassembly



- ① Before removing nylon tubes, hydraulic/fuel hoses, it is necessary to clean the inside of machine to prevent from entrance of dirt and foreign matters.
- ② Perform disassembly work in a dust-free location whenever possible.
- ③ When disassembling parts, wash their outer surfaces and place them on a clean sheet of paper or cloth, taking care not to contaminate or damage them.
- ④ Wash disassembled parts with diesel oil (cleaning solvent) after checking for contamination or discoloration. However, do not wash rubber parts with diesel oil.
- ⑤ Be careful not to damage disassembled parts, they are precision built.
- ⑥ Replace consumables such as oil seals, O-rings, filters, oil, etc. with new items when reassembling parts.
- ⑦ Apply “CALTEX MULTIFAK EP1” to O-ring surface. Never coat the sliding portion of oil seal with grease because it loses sealing effect by stopping screw groove with grease.
- ⑧ When reassembling parts, place each part in the order of assembly and take care that no parts are missing or misassembled.
- ⑨ When reassembling an assembled part (set part), be sure to replace it as an assembly.
- ⑩ Contamination or rusting may occur due to dust or humidity if parts are left in disassembled or partly disassembled condition for a long time. Therefore, be careful to prevent dust or rust from affecting parts if you have to leave the repair incomplete for a long period of time.
- ⑪ Check tightening torque and clearance when assembling parts.
- ⑫ Check the direction of rotation, speed, and oil leakage after assembly.
- ⑬ Before starting the machine after disassembly, run it at low idle to check for unusual noises, etc. to prevent engine or generator damage.

2. Maintenance

2.2 Tightening Torque

2.2.1 General bolts and nuts tightening torque

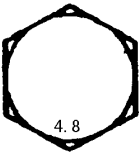
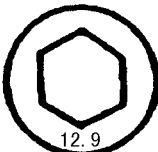
Fasten all the bolts and nuts with the specified tightening torque when assembling.

Kind Strength and sorting Width of across flat Tightening torque Bolt diameter in. (mm)	Low or Middle carbon steel bolt (SS400B etc...)		High tensile strength bolt (SCM435 etc...)		
	4.6-6.8 (4T-6T)		8.8-12.9 (7T-12T)		
	 Hexagon bolts		 Socket bolts	 Hexagon bolts	
	Hexagon bolts Width of across flat in. (mm)	Tightening torque lbf·in.(N·m) [kgf·cm]	Socket bolts Width of across flat in.(mm)	Hexagon bolts Width of across flat in.(mm)	Tightening torque lbf·in.(N·m) [kgf·cm]
0.24 (6)	0.39(10)	44.2(5)[51]	0.20 (5)	0.39(10)	88.5(10)[100]
0.31 (8)	0.51(13)	106.2(12)[124]	0.24 (6)	0.51(13)	221.2(25)[245]
0.39(10)	0.67(17)	221.2(25)[245]	0.31 (8)	0.67(17)	433.6(49)[485]
0.47(12)	0.75(19)	380.5(43)[425]	0.39(10)	0.75(19)	752.2(85)[845]
0.55(14)	0.87(22)	601.8(68)[675]	0.47(12)	0.87(22)	1,194.7(135)[1,350]
0.63(16)	0.94(24)	938.1(106)[1,055]	0.55(14)	0.94(24)	1,858.4(210)[2,100]
0.71(18)	1.06(27)	1,283.2(145)[1,450]	0.55(14)	1.06(27)	2,566.4(290)[2,900]
0.79(20)	1.18(30)	1,814.2(205)[2,050]	0.67(17)	1.18(30)	3,628.3(410)[4,100]
0.87(22)	1.26(32)	2,477.9(280)[2,800]	0.67(17)	1.26(32)	4,955.8(560)[5,600]
0.94(24)	1.42(36)	3,053.1(345)[3,450]	0.75(19)	1.42(36)	6,283.2(710)[7,100]
Applied sections	For general sections such as bonnet and frame.		Receiver tank and other designation part.		

IMPORTANT

- The above torque values in the table shall be applicable for the bolts and nuts used for machine.
- Generally, the abovementioned tightening torques should be followed, but in some points different torque is specified. So use the tightening torque without fail. (See following pages.)
- Make sure to remove rust and dust before tightening.

2. Maintenance

2.2.2 Tightening torque of such important quality parts as bolts and nuts

[Excerpted from HIS C-40940 (company standard)]

	Application parts & portions	Strength classification		Tightening torque : lbf·in. (N·m) [kgf·cm]												Remarks		
		Bolt	Nut	Torque section	Coarse thread / fine thread													
					M6	M8	M10	M12	M14	M16	M18	M20	M22	M24				
1	Air end																	
①	- End cover	10.9	-	4.8	44.2 (5) [51]	106.2 (12) [124]	221.3 (25) [255]	380.5 (43) [425]	-	-	-	-	-	-	-	-	-	for prevention of deformation of outer ring
②	-	-	-	-	-	-	-	-	-	-	-	-	-	-	-	-	-	for prevention of deformation of outer ring
	- Others	12.9	-	8.8	88.5 (10) [100]	221.2 (25) [245]	433.6 (49) [485]	752.2 (85) [845]	1194.7 (135) [1350]	1858.4 (210) [2100]	-	-	-	-	-	-	-	
2	Mounting																	
③	- Mounting bracket	10.9	-	8.8	-	221.2 (25) [245]	433.6 (49) [485]	752.2 (85) [845]	1194.7 (135) [1350]	1858.4 (210) [2100]	2477.9 (280) [2800]	3628.3 (410) [4100]	-	-	-	-	-	with spring washer
④	- Vibration isolator ass'y	-	4.8	4.8	-	106.2 (12) [124]	221.2 (25) [245]	380.5 (43) [425]	601.8 (68) [675]	929.2 (105) [1050]	1327.4 (150) [1500]	1858.4 (210) [2100]	-	-	-	-	use spring washer + nut	
3	Coupling portion between comp. air end and engine																	
⑤	- Housing	4.8	-	4.8	-	106.2 (12) [124]	221.2 (25) [245]	380.5 (43) [425]	601.8 (68) [675]	929.2 (105) [1050]	1327.4 (150) [1500]	1858.4 (210) [2100]	-	-	-	-	with spring washer	
⑥	- Coupling (GEAR, drive)	10.9/12.9	-	8.8	-	221.2 (25) [245]	433.6 (49) [485]	752.2 (85) [845]	1194.7 (135) [1350]	1858.4 (210) [2100]	2477.9 (280) [2800]	3628.3 (410) [4100]	-	-	-	-	with spring washer	
⑦	- Coupling (GEAR, driven)	12.9	-	8.8	-	221.2 (25) [245]	433.6 (49) [485]	752.2 (85) [845]	1194.7 (135) [1350]	1858.4 (210) [2100]	2477.9 (280) [2800]	3628.3 (410) [4100]	-	-	-	-	with lock washer	
4	Lifting portion																	
⑧	- Lifting bail (less than M20)	10.9	4.8	6.8	-	189.3 (18) [183]	327.4 (37) [365]	601.8 (68) [675]	929.2 (105) [1050]	1327.4 (150) [1500]	1858.4 (210) [2100]	-	-	-	-	-	with spring washer	
5	Pressure vessel and pipes																	
⑨	- Separator cover	10.9	-	8.8	-	221.2 (25) [245]	433.6 (49) [485]	752.2 (85) [845]	1194.7 (135) [1350]	1858.4 (210) [2100]	2477.9 (280) [2800]	3628.3 (410) [4100]	4955.8 (560) [5600]	6283.2 (710) [7100]	-	-	-	with spring washer } ※1
⑩	- Flange for pipe (less than M20)	10.9	8.8 ※2	8.8	-	221.2 (25) [245]	433.6 (49) [485]	752.2 (85) [845]	1194.7 (135) [1350]	1858.4 (210) [2100]	2566.4 (290) [2900]	-	-	-	-	-	with spring washer	

※1 When fixing parts of aluminum are used, lock washer shall be used for avoiding damage.
 ※2 Nut shall be of S45C (equivalent to 8.8 of strength classification).

2. Maintenance

1 Air-end

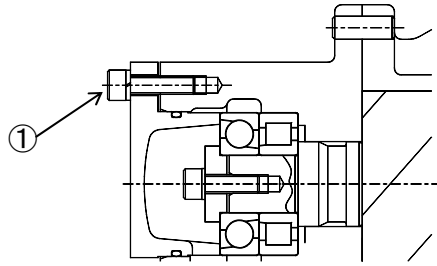

2 Mounting

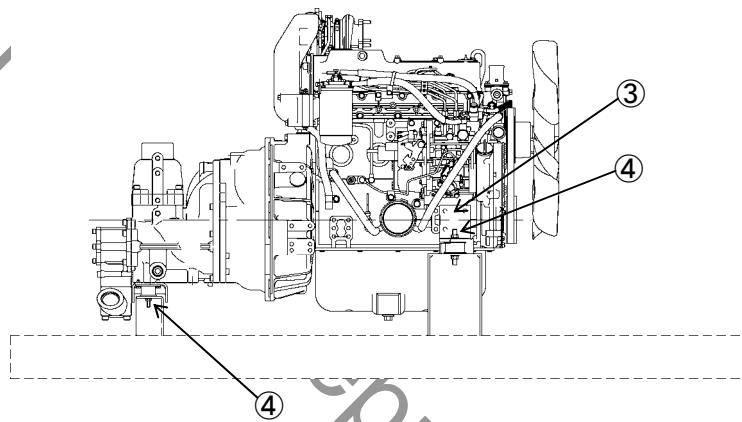

3 Coupling portion between comp. air-end and engine

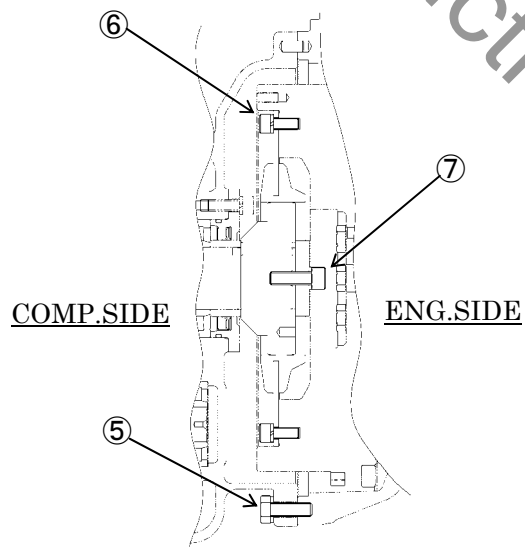

PC14002

2. Maintenance

4 Lifting portion

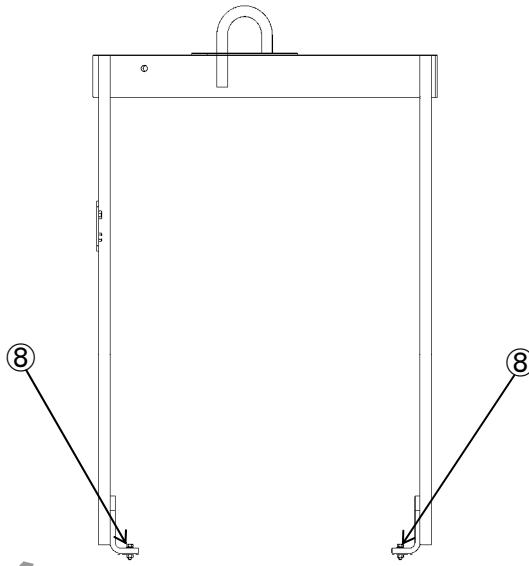

PC14003

5 Pressure vessel and pipes

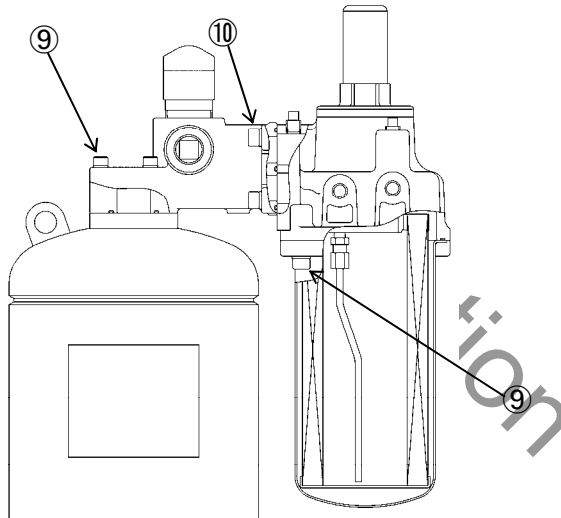

PC14004

2. Maintenance

2.3 How to Adjust Regulator



- When adjusting regulator system, install a silencer to the air delivery port and wear earplugs for protection of hearing damage. Operation with compressed air supply port opened is prohibited.

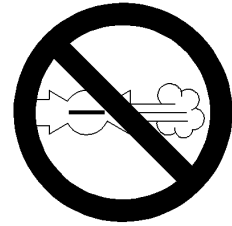

D003

- The speed regulator is already adjusted prior to delivery ex. works. Never change the setting of the regulator by turning bolt and rod recklessly.
- If it is necessary to re-adjust the speed regulator due to overhauling or any trouble, adjust it in accordance with the following procedures.

<How to adjust>

- Adjust by loosening nut “1” and turning adjusting screw “2” .
- Adjust so that engine speed drops when pressure exceeds the unloader starting pressure 100psi (0.69MPa)[6.9bar].
- Make sure to retighten nut “1” after finishing adjustment.

Turning it to right, pressure increases, while turning it to left, it drops.

※ Please refer to clause 1.6.2 for how to adjust engine speed.

- When it is impossible to adjust it, it could be due to the damage of diaphragm “3” . So replace the regulator and try it again.

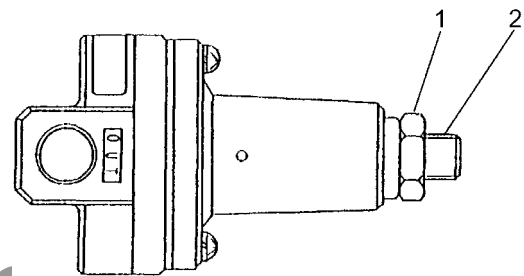

PC13056

Inner structure

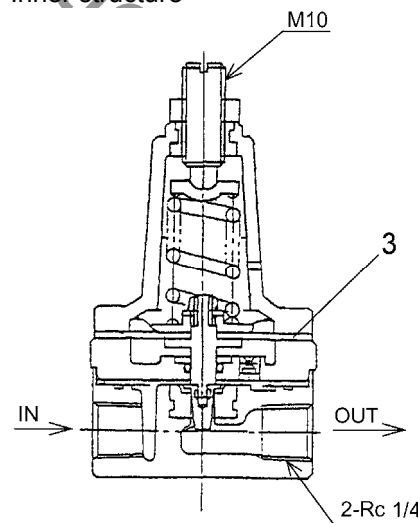

PC13057

2. Maintenance

2.4 Change of Element in Fuel Pre-filter

<Procedure>

- ① Turn fuel selector valve "1" to "OFF" position.
- ② Loosen the drain valve "2" and drain out condensed water inside.
- ③ Turn the cup "3" to the left and remove it. Be careful to remove the cup "3" because it is filled with fuel. Wipe out split fuel completely.
- ④ Remove float "4" inside cup "3" .
- ⑤ Washing element "5" and the cup inside with new fuel.
- ⑥ Replace element "5" and O-ring if they are found broken or damaged.
- ⑦ After finishing clean, assemble it in reverse procedure.
- If air is found still in fuel pipe, place starter switch to "RUN" position and loosen air bleeding bolt "6" to bleed air. After finishing air bleeding, tighten the air bleeding bolt "6" .
- Drain the condensate in container, and then dispose of condensate according to the designated regulations.

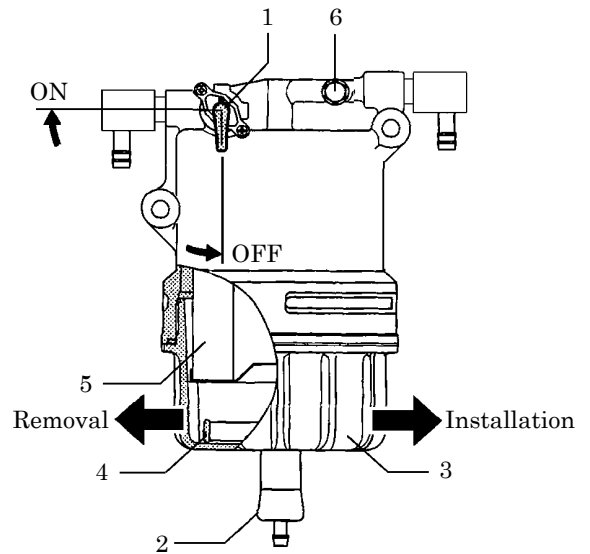

A130967

[Tightening torque of cup "3"]

 : 239–292lb·in(27–33N·m)[280–340kgf·cm]

2. Maintenance

2.5 Change Oil Separator

IMPORTANT

- When changing the oil separator, both cover and element must be replaced with new ones.

- Even before the periodic interval time of replacement, replace the oil separator whenever the oil consumption increases and also oil is found mixed in the discharge air.
- When consumption of the oil is still unusual even after cleaning strainer in the scavenging orifice, change the oil separator with a new one.

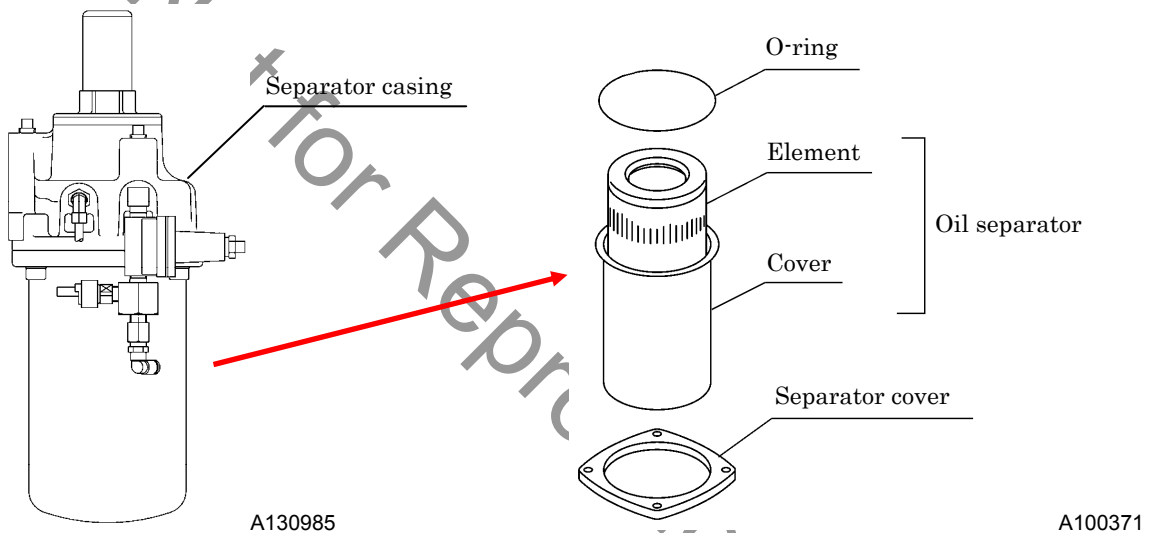

[Tightening torque of separator cover bolt]

 : 0.31 in. (8 mm)

 : 433.6 lbf·in. (49 N·m) [485 kgf·cm]

2. Maintenance

2.6 Change O-ring of Unloader

<Caution during O-ring replacement>

- When changing O-ring “1” , “2” , “3” , and “4” , coat slightly the sliding surface with grease.

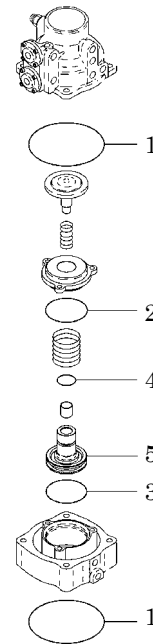

PC14005

<Replacement of O-ring “4”>

- O-ring “4” is composed of O-ring and resin ring (generally called Teflon ring). When attaching it, the resin is likely to expand and change itself. So replace the O-ring, following the procedures undermentioned.

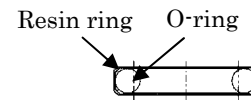

PC14006

CAUTION Do not wear gloves for this job.

- ① Coat O-ring “4” with grease, and install it in the O-ring groove of the piston “5” .
- ② Coat the resin ring with grease, and install it on the O-ring “4” which is installed in ①.

IMPORTANT The resin ring is likely to be deformed if it is pulled with force. So install it by using the following insertion tool.

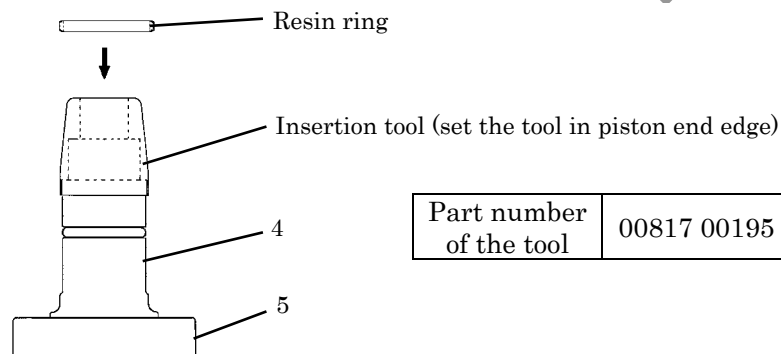

Part number of the tool	00817 00195
----------------------------	-------------

PC13127

2. Maintenance

- ③ Slightly coat inner circumference portion of the correction tool with grease and insert it into the piston “5” and then correct the resin ring.

IMPORTANT Insert the ring gradually to the piston, correcting it and paying attention not to get caught.

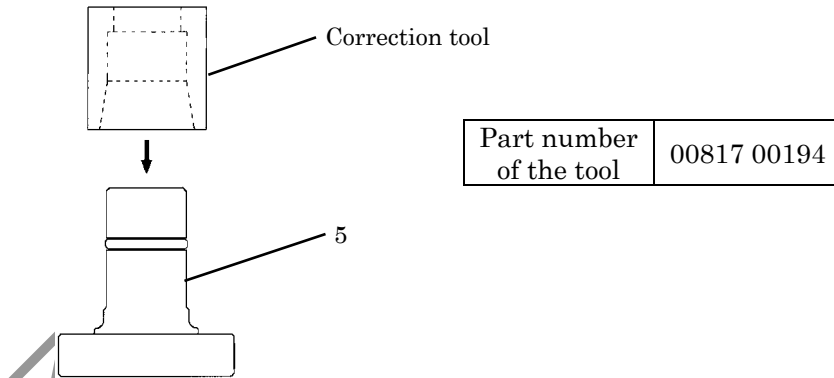

PC13128

- ④ After having inserted it, pull out the correction tool and check and confirm that the resin ring is properly installed. If deformed, repair it and correct it.

IMPORTANT

- When reinstalling it, check and confirm that there are no foreign matters and dust in O-ring groove and on the O-ring. Then, coat O-ring with grease slightly. Use CALTEX MULTIFAK EP1 grease or equivalent. Grease of poor quality will deteriorate the material.

2. Maintenance

2.7 Change O-ring of Auto-relief Valve and Vacuum Relief Valve

- After disassembling and cleaning the component, check the O rings “1” , “2” and “3” . When the rubber of these rings is found hardened, replace any one of them.

- ※ O-ring “2” and “3” are damaged due to removal of piston “4” , but remove unloader cover “5” and insert a wire through (A) hole (2.5 drill) from inside to push it out. At this time, replace O-ring “6” .

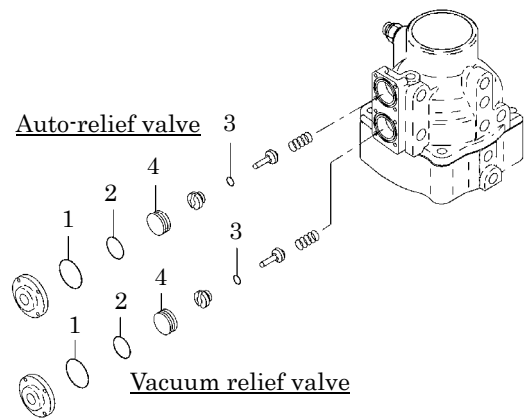

PC14007

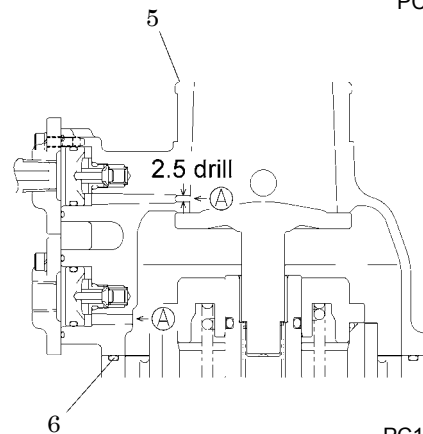

PC14008E

IMPORTANT

- When reinstalling it, check and confirm that there are no foreign matters and dust in O-ring groove and on the O-ring. Then, coat O-ring with grease slightly. Use CALTEX MULTIFAK EP1 grease or equivalent. Grease of poor quality will deteriorate the material.

2. Maintenance

2.8 Maintenance and Adjustment of Pressure Control Valve

<Procedure>

- ① If the discharge pressure drops lower than 51psi(0.35MPa)[3.5bar] during operation, replace the spring “3” of pressure control valve. After confirming that the compressed air in the pipes is completely relieved, disassemble the valve.
- ② When O-ring “1” and “2” are found deteriorated and/or hardened, replace them even before periodical interval of replacement.
- ③ When the piston “4” is found worn or damaged, replace it.

After replacement, run the machine to check its function, air-leak or any disorder.

Setting pressure:

$$58.2^{+14.6}_{-1.5} \text{ psi} (0.4^{+0.1}_{-0.05} \text{ MPa}) [4^{+1}_{-0.5} \text{ bar}]$$

- ④ When the indicator shows excessively higher pressure, you will find that the piston does not move smoothly due to foreign material and rust stuck inside valve. In such a case, disassemble the component for checking and cleaning.

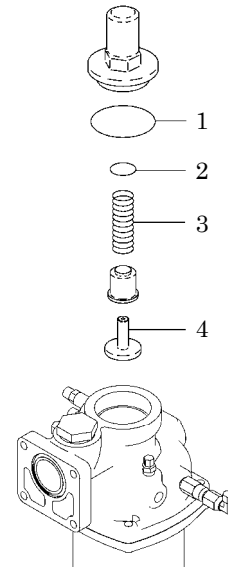

A130986

IMPORTANT

- When reinstalling it, check and confirm that there are no foreign matters and dust in O-ring groove and on the O-ring. Then, coat O-ring with grease slightly. Use CALTEX MULTIFAK EP1 grease or equivalent. Grease of poor quality will deteriorate the material.

2. Maintenance

2.9 Change of Pellet assembly of By-pass Valve

- By-pass valve fitted on this unit is of full bore type. While the unit is used for normal operation, it is not to perform periodical replacement of the inner pellet assembly, but when such trouble as excessive rise of compressor oil temperature, it becomes necessary to replace it, in accordance with the following procedures.

<Procedure>

- ① First stop the unit and make sure that there is no residual pressure left in the separator receiver tank.
- ② After checking and confirming that the temperature of compressor oil has become amply low, open drain valves on separator receiver tank and oil cooler to empty compressor oil completely.
- ③ After draining compressor oil, remove bolt “1” and then the pellet assembly “2” of the by-pass valve and O-ring “3” .
- ④ Replace the pellet assembly “2” and O-ring “3” by new ones. Install O-ring “3” coated thinly with compressor oil.
- ⑤ Supply compressor oil through the filler port provided on the receiver tank. (Refer to instruction manual)
- ⑥ Start operation and check the function of by-pass valve. (It functions well when delivery air temperature will not rise abnormally.)

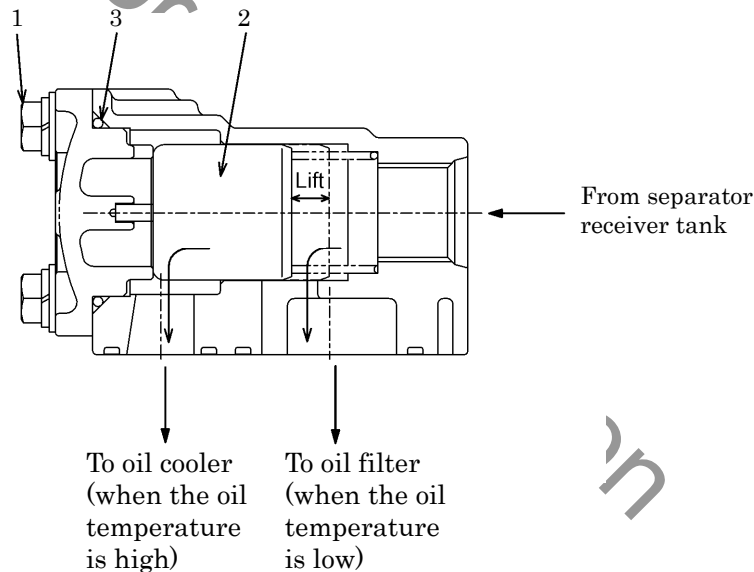

PC14009E

Actuating temperature	By-pass valve fully closing temperature
180±37°F (82±3°C)	192±36°F (89±2°C)

2. Maintenance

2.10 Air Bleeding in Fuel Line

- Should the machine stop due to fuel shortage, perform air bleeding according to the following steps.

<Procedure>

- ① Replenish fuel.
- ② When starter switch is turned to "RUN" position, electromagnet pump starts to automatically bleed air in fuel line.
- ③ Air bleeding is completed about 1 minute.

IMPORTANT

- Engine will never startup until finish air breeding even though starter switch is turned to "START" position.
- Never hold the key in the "START" position for longer than 15 seconds or the starter motor will overheat.
- When the engine fails to startup even after performing the startup procedures, do not keep the starter running, but set the starter switch back to "STOP" and wait about 2 minutes. Then, repeat the startup procedure once again.

2.11 Clean Inside of Fuel Tank

- Condensate is caused and accumulated at the bottom of fuel tank, owing to churning of dust or dirt mixed when fuel oil is fed and water drop caused while fuel oil tank is used for a long time. When any condensate is found afloat and fuel filter gets clogged too fast, fuel oil tank should be cleaned after condensate is removed from fuel oil tank even before the specified cleaning interval time.

<Procedure>

- ① Open drain valve to remove fuel oil from fuel tank.
- ② Remove side cover under door.
- ③ Remove fuel pipes and wires connected to fuel tank.
- ④ Remove belt holding fuel tank and remove tank.
- ⑤ Insert cleansing nozzle through fuel filler port or drain port for cleaning tank.
- ⑥ After cleaning job is finished, install fuel tank from which water or the like should be completely removed.

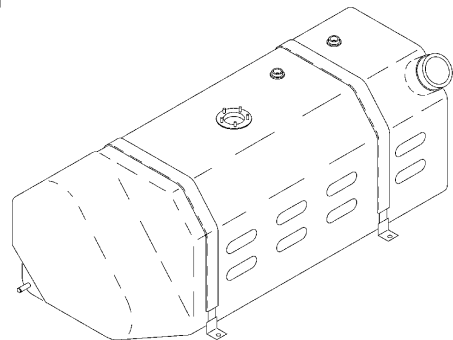

PC08022

2. Maintenance

2.12 Clean Drain Separator (Option: With aftercooler only)

- When the condensate cannot be drained out, being clogged with dirt, dust, and sludge, sludge accumulated at drain port during long operation and depending on environment conditions, clean drain separator.

<Procedure>

- ① Turn the ball “2” till the mark ▲ of the latch “1” meets the mark ▲ of the body (about 45°) with a finger.
- ② Pull down the ball “2” and check the outlet port “3” for any clogging and clean it.
- ③ After finishing clean, assemble it in reverse procedure.

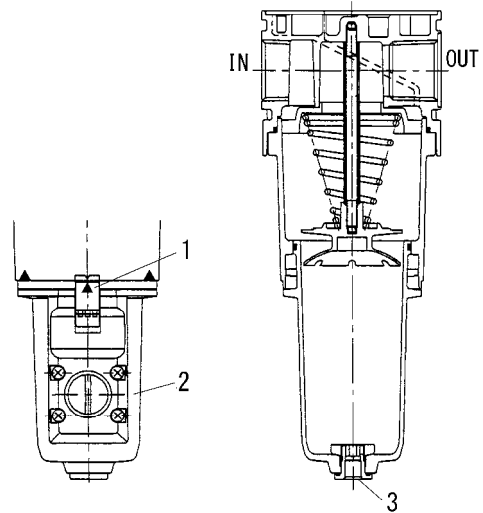

PC12003

2.13 Values of Various Adjustments of Engine

Item		Unit		
Engine model			YANMAR 4TNV88C-DHKS	
Tightening torque of head bolts		lbf·in. (N·m) [kgf·cm]	First time	364.6–416.6(41.2–47.1)[420–480]
			Second time	755.2–807.2(85.3–91.2)[870–930]
Valve clearance	Air intake	in.(mm)	0.0079±0.0020(0.20±0.05) (when engine is cold)	
	Discharge	in.(mm)	0.0079±0.0020(0.20±0.05) (when engine is cold)	
Firing order			1-3-4-2-1 (No.1 cylinder at flywheel side)	
Injection timing (BTDC)		°	Electronic control unit	
Nozzle injection pressure		psi(MPa)[bar]	—	
Compression	Standard	psi(MPa)[bar]	470±14.5(3.24±0.1)[32.4±1]	
	Working limit	psi(MPa)[bar]	Limited value	370±14.5(2.55±0.1)[25.5±1]
			Each cylinder limit value	29–43.5(0.2–0.3)[2–3]
Thermostat	Temperature for start of release	°F(°C)	160±34.7(71±1.5)	
	Full open temperature	°F(°C)	185(85)	
	Valve lift	in.(mm)	More than 0.31(8.0)	

※For the details, see service manual supplied by engine manufacturer.

3. Electric System

3.1 Electronic Control System of Engine

[Excerpted from YANMAR SERVICE MANUAL]

3.1.1 Electronic control system

Model TNV engines come with the Common Rail System and the Exhaust Gas Recirculation (EGR) system to conform to the engine emission regulations (EPA 2012 rules).

The electronic engine control system regulates the exhaust gas recirculation flow rate and the fuel injection volume depending on the engine load and speed signals from the engine controller (ECU), so that the exhaust gas is kept clean according to the emission control regulations.

Also, control the diesel particulate filter (DPF) regeneration mode operation by managing the condition of the DPF (clogging) by controlling the intake throttle.

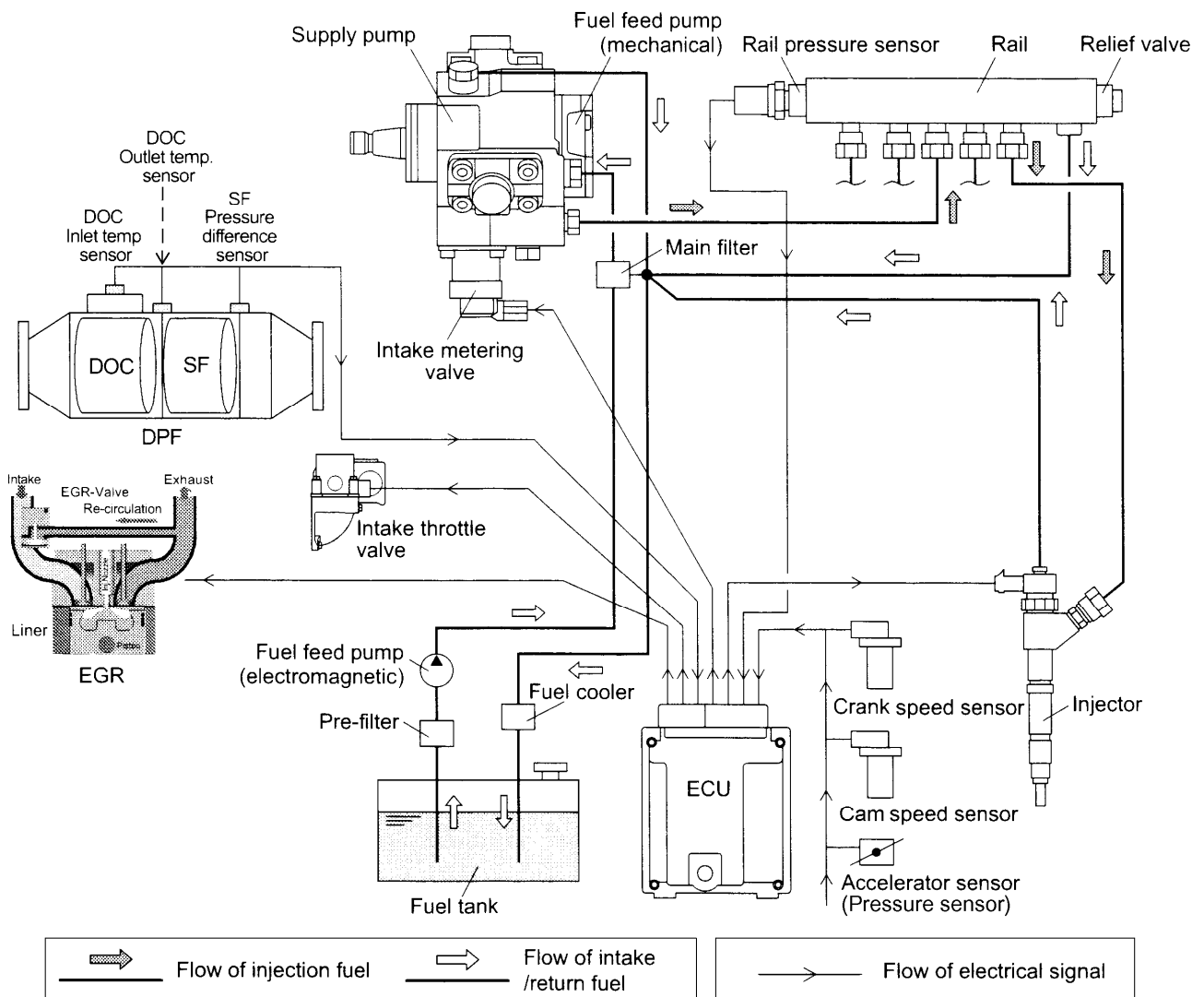

PC14010E

3. Electric System

3.1.2 Acceleration control

Emergency controller (control of output and engine speed) receives electric signal outputted from pressure sensor, and it controls electronic fuel injection system by outputting to engine controller.

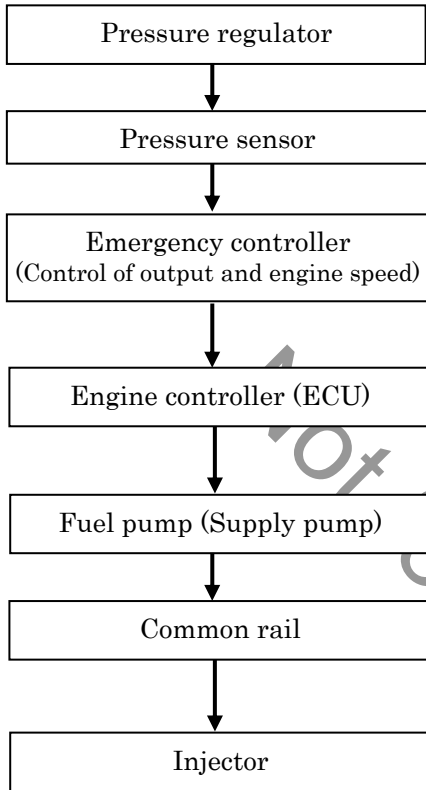

The pressures at 2nd stage is converted into voltage and outputted.

The inputted voltage (pressure signal) is converted into voltage again, and it outputs to engine controller (ECU).

Engine speed and engine output are adjusted by controlling fuel injection timing injection quantity, injection pressure and injection frequency with indication of target speed to be inputted.

It supplies fuel to the common rail.

It stores the high pressure fuel forcefully sent from the supply pump and it distributes the fuel to the injectors.

It injects the high pressure fuel which is made in common rail according to the signal sent from ECU according to the optimum injection timing, injection quantity, injection rate, injection frequency and injection conditions.

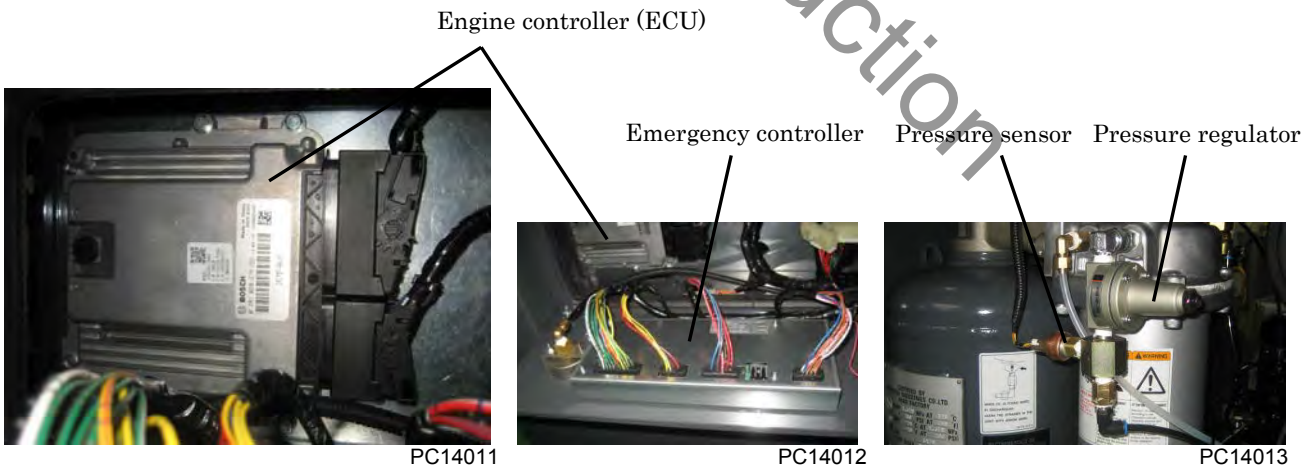

3. Electric System

3.1.3 Diesel particulate filter (DPF)

The DPF consists of the diesel oxidation catalyst (DOC) and the SF, held by a case that sends the exhaust gas to the DOV and the SF.

The role of the DPF is to prevent the discharge of PM by breaking down the hazardous constituents with the DOC and collecting the PM with the SF. The PM clogs the SF if left there and the engine performance decreases, so a means of regeneration is required. This engines use a continuous regeneration method. While continuing the operation, the DPF collects the PM and is regenerated at the same time. To perform the regeneration, the PM collected in the SF is combusted with NO₂ generated in the DOC and O₂ in the exhaust gas. At the same time, the DOC purifies the exhaust gas elements such as HC and CO into H₂O and CO₂.

Apart from the PM, ash also collects in the SF. This comes mostly from metallic components in the additives to the lubricating oil. Part of the lubricating oil is burnt in the high temperature combustion chamber and exhausted along with the combustion gas. In that case, metallic components are collected together with the PM in the SF. However, because the amount of ash is very little compared to the PM, it does not clog the SF immediately. Because ash is a metallic component, it cannot be combusted in the DPF for treatment like the PM. Therefore, ash is over-accumulated in the SF over a long period of time. This increases the pressure loss and has adverse effects on the engine. In this case, maintenance must be performed to remove the SF with the accumulated ash from the DPF. SF recommends removal maintenance at every 3,000 hours operation and DOC recommends replacement at every 9,000 hours operation.

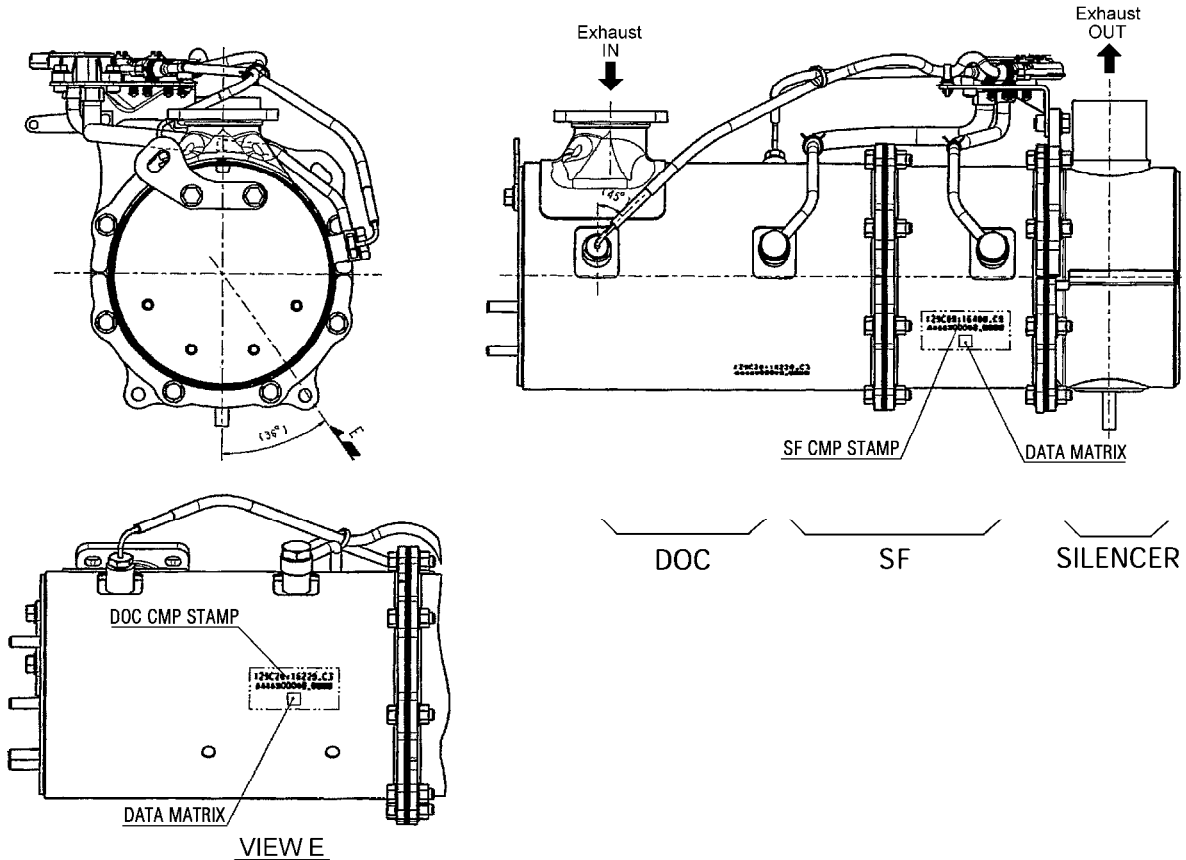

PC14014E

3. Electric System

3.1.4 DPF regeneration control

DPF differential pressure sensor and temperature sensor are installed in the DPF. If the DPF cannot perform continuous regeneration due to low load operation, the ECU uses these electrical components to control assisted DPF regeneration (DPF regeneration control) automatically to prevent PM from over-accumulating.

The engine is equipped with the following DPF regeneration mode (It has a function to regenerate the accumulated soot and removes it.).

[Passive regeneration]

Regeneration without the use of regeneration assistance devices (normal)

During the operation at high speed or high load, the exhaust temperature rises and PM is continuously combusted and eliminated.

[Active regeneration-1]

Regeneration with the use of assistance devices (e.g. the intake throttle)

When the differential pressure in the SF inlet/outlet in the DPF rises, the differential pressure sensor installed to the DPF detects the increase. The ECU commands the intake throttle to open the throttle according to the detected differential pressure to adjust the amount of engine intake air. The ECU also controls the regeneration by performing after-injection to increase the exhaust temperature. At this time, the EGR valve is closed.

[Active regeneration-2]

Approximately every 100 hours of operation, the active regeneration-1 and post-injection are automatically used together to control regeneration by increasing the exhaust temperature to burn off and remove PM.

These automatic regenerations can be performed during operation. No special operation is required for the operator. The following conditions may occur due to the characteristics of the DPF system, but they are not malfunctions.

- The engine sound may change during the idling operation at no load.
- White smoke may be discharged from the exhaust pipe right after starting a cold engine or during acceleration.
This is due to discharge of water vapor. When the exhaust temperature increases, the white smoke disappears.
- The exhaust gas is purified through the catalyst installed in the DPF, so the smell of the exhaust gas is different from the exhaust gas of a conventional diesel engine.
- During active regeneration-2, post-injection is used and fuel is burned directly inside the DPF (burned by chemical reaction inside the DOC). Through this heat, regeneration occurs inside the SF, but the combustion increases the temperature of the exhaust gas to close to 1112°F (600°C).
Be careful that neither people nor flammable materials are near the exhaust gas outlet.
- Post-injection can cause the fuel consumption to increase by a small amount.

3. Electric System

- The dilution of the lubricating oil with fuel caused by the post-injection is kept to a minimum, but some dilution is possible for low-load operation (low temperature exhaust gas). Make sure that you do a daily check of oil level.

※Active regeneration-1 and active regeneration-2 are collectively explained as “active regeneration” in the instruction manual.

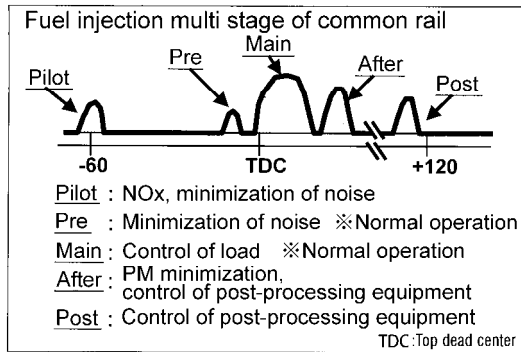

PC14015E

[Manual regeneration]

Although the DPF performs the regeneration control, if the operation conditions with idling at no load and low speed/low load operation are frequently repeated, the PM may not be combusted. If the ECU determines that performing the manual regeneration is required at this time, the DPF regeneration required lamp lights up. If the DPF regeneration required lamp is lit, immediately conduct the manual regeneration by performing the following operation.

3. Electric System

<Manual regeneration procedure>

- ① Regeneration required lamp “1” and error lamp “4” go on. At the same time, regeneration lamp “5” flashes. And also engine speed automatically changes to 1,350 min⁻¹.
- ② Close service valve.
- ③ Keep pressing regeneration switch “3” longer than 3 seconds.
- ④ Regeneration required lamp “1” lights off and cleaning exhaust filter lamp “2” goes on, then regeneration lamp “5” changes to lighting on instead of flashing and at the same time it automatically starts purge operation.
- ⑤ Engine speed gradually increases up to approximately 2,200 min⁻¹.
- ⑥ Under this state, manual regeneration operation is performed about 30 minutes. (※)
- ⑦ All lamps go off and manual regeneration operation comes to end, and it returns to normal engine speed and normal operation starts.

※Time of regeneration varies upon the ambient temperature.

- When continuing operation about ten hours without conducting manual regeneration even while regeneration required lamp “1” is lighting, it will be impossible to conduct manual regeneration and it leads to low idling operation only. In this case, it becomes necessary to clean DPF (Diesel particulate filter). Please contact our nearest dealer.

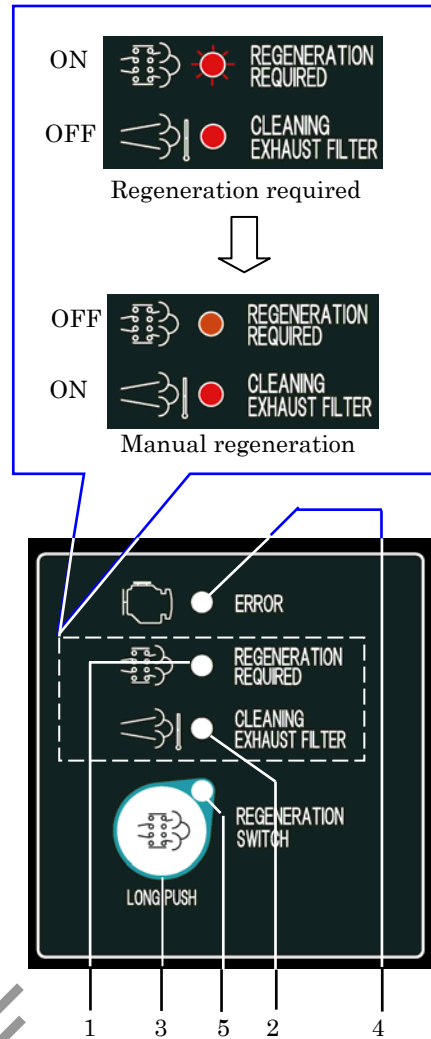

A130992

IMPORTANT

- When DPF regeneration required lamp goes on, take immediate specified action to conduct manual regeneration. If it is continuously operated without manual regeneration, excessive soot will accumulate and it could damage DPF due to abnormal burning, and it could cause a fire.

CAUTION

- Do not stop engine during enforced regeneration operation, except for unavoidable conditions.

3. Electric System

3.1.5 Preheating control

[ON glow control (Pre-heat)]

When the starter switch is placed "RUN" position automatically the glow plug relay is electrified in accordance with the time applied to coolant temperature. Being electrified, the preheat lamp goes on at the same time.

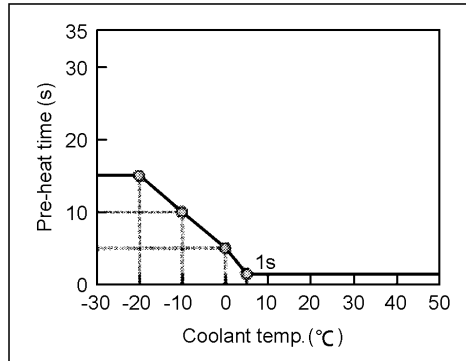

PC14016E

[Simultaneous electrification control]

While starter is working with the starter switch placed on "START" position, glow plug relay is electrified.

Also the conditions to end simultaneous electrification control is to be ended by engine starting signal (When the starter switch is operated on the other position than "START" position, glow plug relay is not electrified).

3. Electric System

3.2 Emergency Controller

Part number:46870 64001

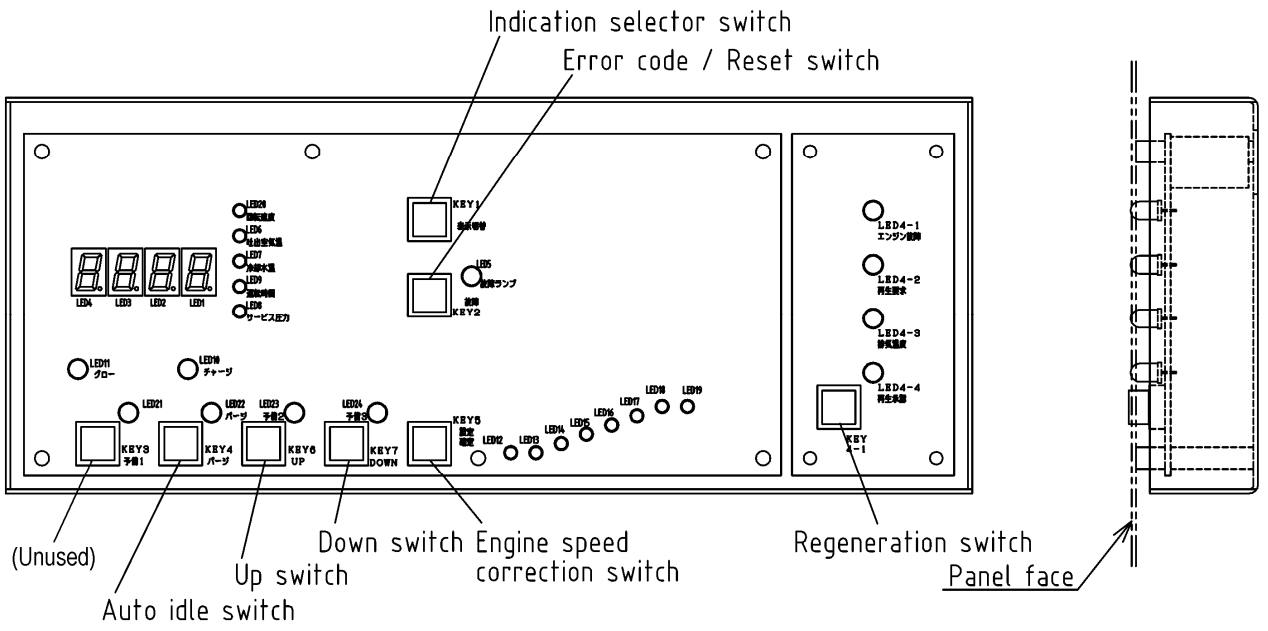

PC14017E

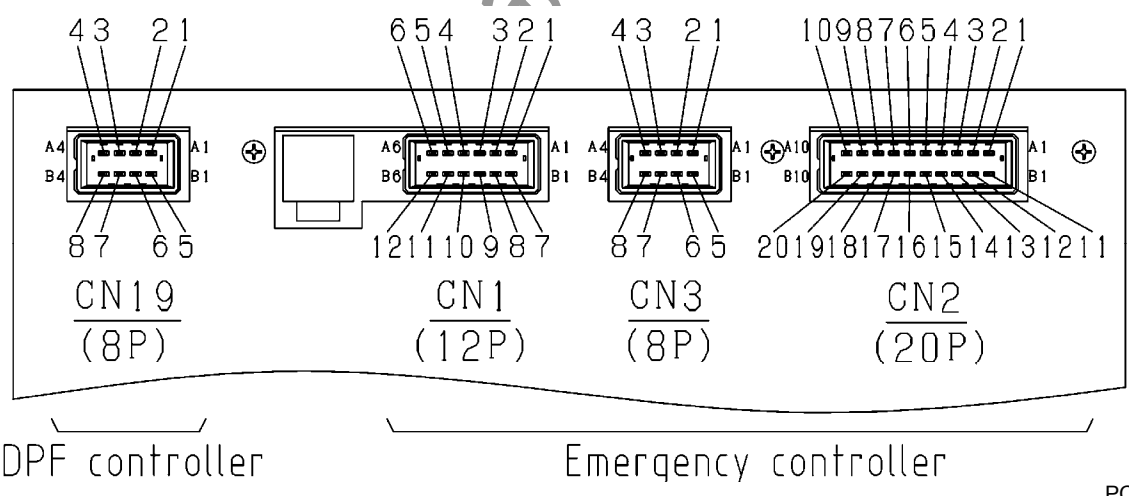

PC14018E

3. Electric System

1. Exterior connection drawing

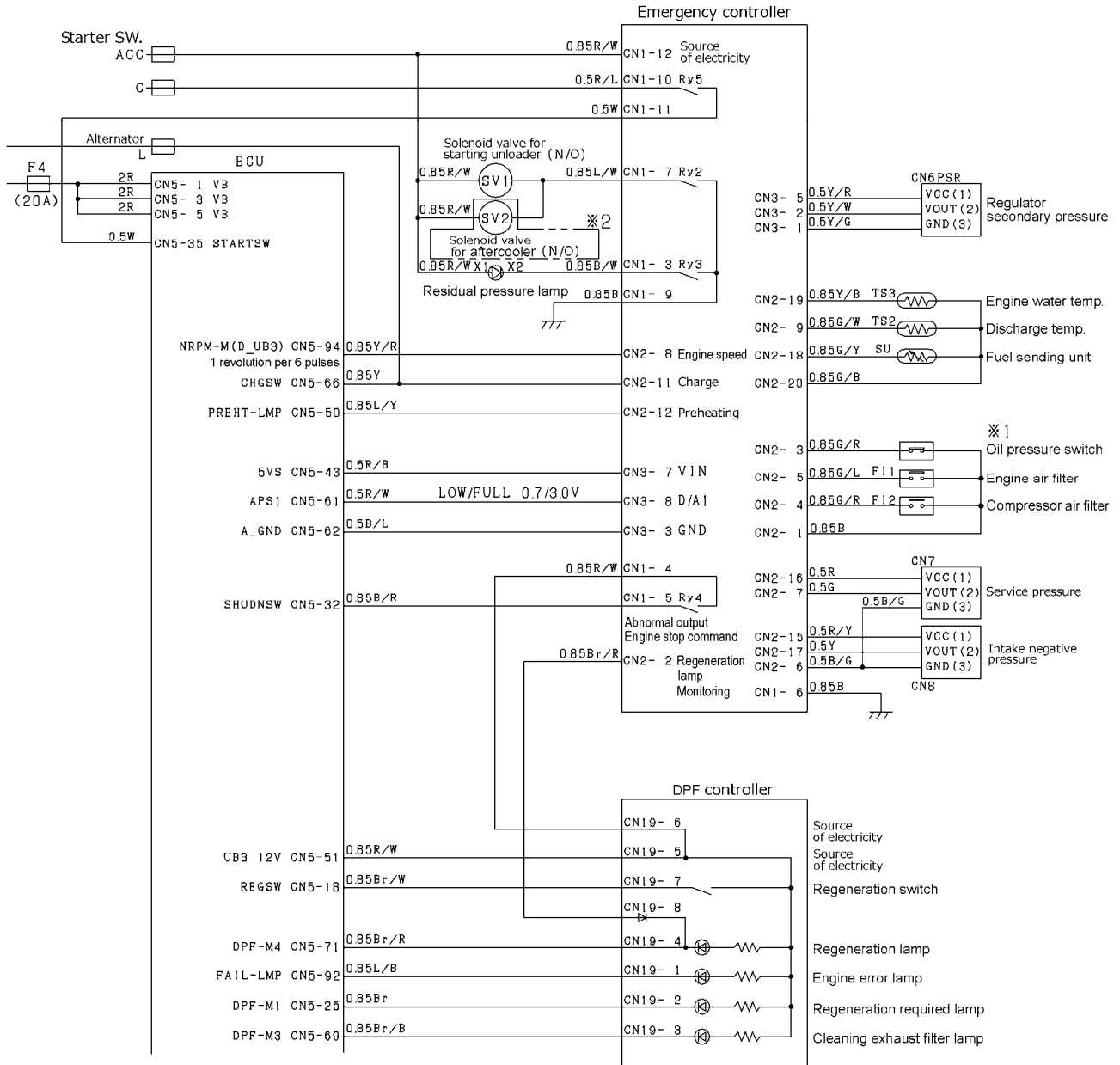

PC14019E

※1 As engine oil pressure switch contact is B, the contact is ON when engine shuts down. After engine starts, the contact becomes OFF due to rise of engine oil pressure. Oil pressure detecting circuit of controller functions at circuit of contact A. After engine oil pressure switch is kept ON for 2 seconds, engine is brought to emergency stop. (Engine oil pressure abnormality detecting circuit functions 20 seconds after it detects alternator generation signal.)

※2 Equip in the aftercooler with of options.

● Auto idle switch is fitted on the operation panel (emergency controller), but it is not indicated in the connection diagram.

3. Electric System

2. Timing of each output relay

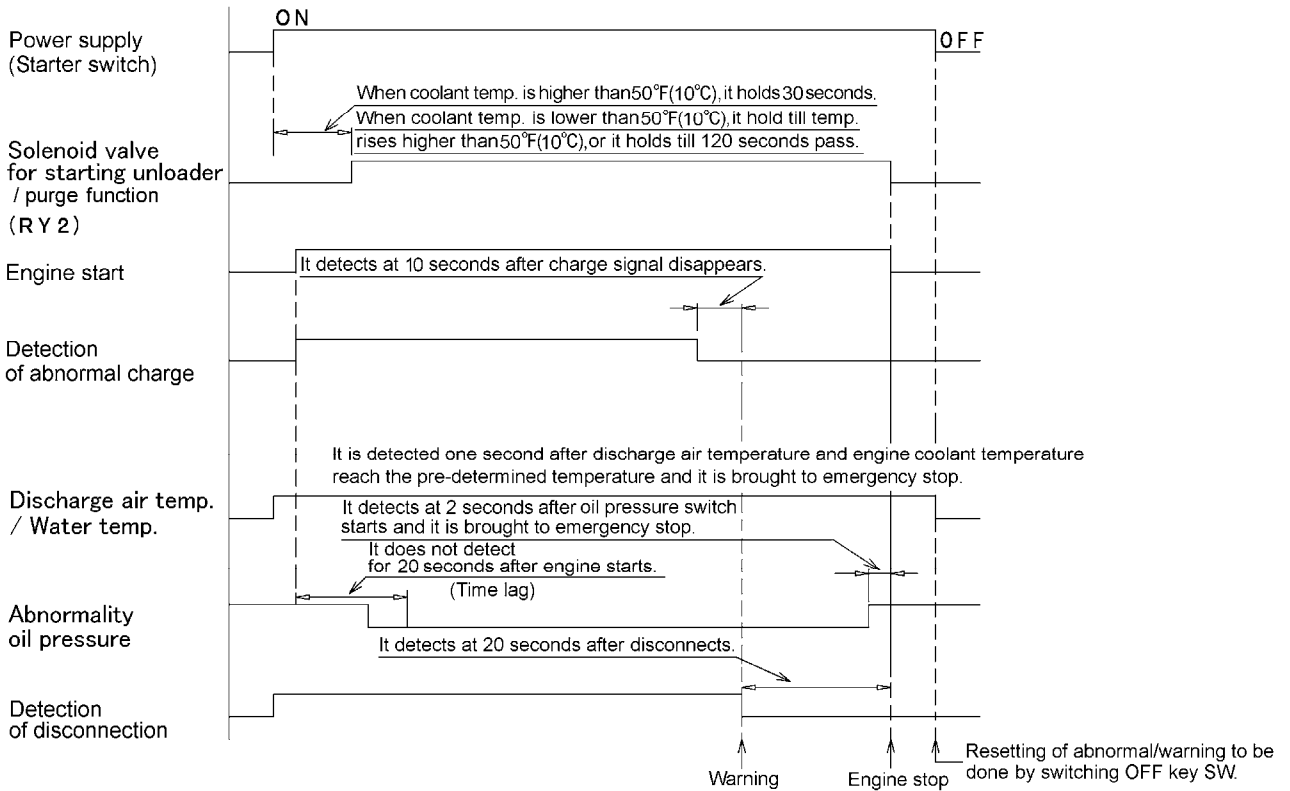

PC14020E

3. Warning · emergency display and emergency stop functions

	Item	Indicator	Sensor		Actuation	Detecting timing	Time lag
Warning	Discharge temp. H	A-1	Thermister	—	Lamp goes on at 239°F(115°C)	Always	120 sec
	Water temp. H	A-2	Thermister	—	Lamp goes on at 221°F(105°C)	Always	120 sec
	Comp. air filter	A-3	Negative pressure sw.	A contact	Differential pressure is more than 0.9psi(6.23kPa)[0.06bar]	Always	10 sec
	Eng. air filter	A-4	Negative pressure sw.	A contact	Differential pressure is more than 0.9psi(6.23kPa)[0.06bar]	Always	10 sec
	Charge	A-5	—	—	Charge signal disappears and lamp goes on	After starting engine	10 sec
Emergency	Discharge temp. H	E-1	Thermister	—	Lamp goes on at 248°F(120°C)	Always	1 sec
	Water temp. H	E-2	Thermister	—	Lamp goes on at 230°F(110°C)	Always	1 sec
	Eng. oil press.	E-3	Pressure sw.	B contact	Lamp goes on when oil pressure is lower than 7.1psi(0.049MPa)[0.49bar]	20 seconds after engine starts	2 sec
	Discharge temp. sensor	E-6	Thermister	—	Disconnected and lamp goes on	After starting engine	20 sec
	Water temp. sensor	E-7	Thermister	—	Disconnected and lamp goes on	After starting engine	20 sec

- Warning : Compressor continues to run.
- Emergency : Compressor stops.

3. Electric System

4. Functions of each output relay

Mark	Name	Function	
RY2	Relay for starting unloader	It goes OFF when starter switch is ON.	Coolant temperature: Lower than 50°F(10°C)··· When coolant temp. is higher than 50°F(10°C), or when 120 seconds pass, it becomes ON. Coolant temperature: Higher than 50°F(10°C)··· It becomes ON 30 seconds later.
RY2	Purge function relay	(Relay is continuously OFF when purge switch is ON.)	
RY3	Relay for residual pressure start prohibition lamp	It goes ON when starter switch is ON.	Separator receiver tank pressure: ON in case of more than 14.6psi(0.1MPa)[1bar] OFF in case of lower than 7.3psi(0.05MPa)[0.5bar]
RY4	Abnormality output relay	OFF during normal operation, but ON on abnormal operation.	
RY5	Relay for residual pressure start prohibition	It goes ON when starter switch is ON.	Separator receiver tank pressure: OFF in case of more than 14.6psi(0.1MPa)[1bar] ON in case of lower than 7.3psi(0.05MPa)[0.5bar]

5. Adjustment and inspection

Perform the detection and inspection of discharge temperature, engine water temperature, and sending unit by controller in the following steps.

- (1) Connect resistance to controller as shown right.
Or use multi-speed variable resistance (resistance value: 1.0kΩ) for VRc1, VRc2 and VRc3.

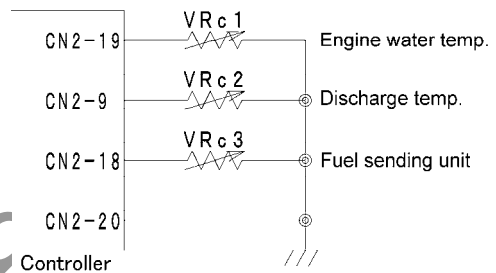

PC10027-1E

- (2) Gradually lower resistance values of VRc1 and VRc2 and measure them when they reach abnormal values. Then check and confirm that they are within the following ranges.

Item	Indicator	Set temperature		Resistance (Ω)
		(°C)	(°F)	
Engine water temperature VRc1	Warning	105	221	640 ± 15
	Emergency	110	230	560 ± 15
Discharge temperature VRc2	Warning	115	239	491 ± 15
	Emergency	120	248	432 ± 15

- (3) Sending unit

Float position	Resistance (Ω)
F	3.0 ± 2.0
1/2	32.5
E	110.0 ± 7.0

3. Electric System

6. Pressure sensor / Emergency controller Output – revolution speed list (for reference only)

The voltage values in the following table are standard reference ones. They are different a little from actual ones during operation.

Output voltage of pressure sensor

Pressure sensor	
Regulator secondary pressure psi(MPa)[bar]	Output voltage (DCV)
0.0	0.5
21.8(0.15)[1.5]	1.1

Voltage outputted from emergency controller to engine controller (ECU)

Emergency controller (control of output and engine speed)		
Output voltage (DCV)	Accelerator (%)	Engine RPM (min^{-1})
3.0	100	3,000
0.7	0	1,350

3. Electric System

3.2.1 Emergency controller

(1) List of CN1 terminal functions (12 pins)

Pin No.	Line color	Connection	Function
CN1-1	—	NIL	
CN1-2	—	NIL	
CN1-3	B/W	Residual pressure start prohibition lamp	When more residual pressure than 14.6psi (0.1MPa)[1bar] is left in the receiver tank, Ry3 relay of emergency controller becomes “ON” and alarm lamp goes on.
CN1-4	R/W	DPF controller CN19-6 terminal	Power supply (DC12V)
CN1-5	B/R	Engine controller (ECU) CN5-32 terminal	When Ry4 relay of emergency controller is “ON”, it sends abnormality signal to ECU to stop engine.
CN1-6	B	Grounding	
CN1-7	L/W	<ul style="list-style-type: none"> · Solenoid valve SV1 for starting unloader / purge · Solenoid valve SV2 for aftercooler drain (Option) 	<ul style="list-style-type: none"> · When starter switch is ON at start-up, and emergency controller CN1-12 terminal voltage is electrified, starting unloader solenoid valve (SV1) and aftercooler drain solenoid (SV2) is OFF till the following time by coolant temperature. · When purge switch is turned ON, SV1 functions continuously and it is operated at engine speed of approximately 1,400 min⁻¹. <p>The time when SV1 and SV2 are OFF</p> <ul style="list-style-type: none"> ● Coolant temperature: Lower than 50°F(10°C): 120 seconds or the time till coolant temperature rises higher than 50°F(10°C) ● Coolant temperature: Higher than 50°F(10°C): For 30 seconds
CN1-8	—	NIL	
CN1-9	B	Grounding	
CN1-10	R/L	Starter switch C terminal	<ul style="list-style-type: none"> · Inputting start signal. · When more residual pressure than 14.6psi (0.1MPa)[1bar] is left in the receiver tank, Ry5 relay of emergency controller is made OFF and start is locked.
CN1-11	W	Engine controller (ECU) CN5-35 terminal	Inputting start signal to ECU
CN1-12	R/W	Starter switch Acc terminal	Power supply (DC12V)

(2) List of CN2 terminal functions (20 pins)

Pin No.	Line color	Connection	Function
CN2-1	B	Common of oil pressure switch, engine air filter, compressor air filter	Grounding
CN2-2	Br/R	DPF controller CN19-8 terminal	When regeneration lamp lights continuously, purge solenoid valve (SV1) is made to work for forced purge operation.

3. Electric System

Pin No.	Line color	Connection	Function
CN2-3	G/R	Engine oil pressure switch	When engine oil pressure drops to the set pressure of emergency stop, it makes emergency controller Ry4 relay ON and it sends abnormality signal to ECU to stop engine. ●Emergency stop set oil pressure : 7.1psi(0.049MPa)[0.49bar]
CN2-4	G/R	Compressor air filter	It detects clogging of compressor air filter, and it enables alarm lamp to blink. ●Differential pressure for warning function : More than 0.9psi(6.23kPa)[0.06bar]
CN2-5	G/L	Engine air filter	It detects clogging of engine air filter, and it enables alarm lamp to blink. ●Differential pressure for warning function : More than 0.9psi(6.23kPa)[0.06bar]
CN2-6	B/G	Service pressure sensor Intake negative pressure sensor	Grounding
CN2-7	G	Service pressure sensor Vout terminal	Detection of service pressure.
CN2-8	Y/R	Engine controller (ECU) CN5-94 terminal	It outputs engine speed. ●Revolution ratio (pulse type) : 6 pulses per 1 revolution
CN2-9	G/W	Discharge temperature sensor	When discharge air temperature rises over the emergency stop pre-determined temperature, it makes emergency controller Ry4 relay ON and it sends abnormality signal to ECU to stop engine. ●Emergency stop set temperature : 248°F(120°C)
CN2-10	—	NIL	
CN2-11	Y	· Engine controller (ECU) CN5-66 terminal · Alternator L terminal	It detects deficiency of charging battery, and it enables alarm lamp ON.
CN2-12	L/Y	Engine controller (ECU) CN5-50 terminal (Preheating lamp)	When preheating, it receives preheat signal from ECU CN5-50 terminal and it enables preheat lamp ON.
CN2-13	—	NIL	
CN2-14	—	NIL	
CN2-15	R/Y	Intake negative pressure sensor Vcc terminal	Power supply (DC5V)
CN2-16	R	Service pressure sensor Vcc terminal	Power supply (DC5V)
CN2-17	Y	Intake negative pressure sensor Vout terminal	Detection of intake negative pressure.
CN2-18	G/Y	Fuel sending unit	For detecting residual fuel.
CN2-19	Y/B	Engine water temperature sensor	When coolant temperature rises over the emergency stop pre-determined temperature, it makes emergency controller Ry4 relay ON and it sends abnormality signal to ECU to stop engine. ●Emergency stop set temperature : 230°F(110°C)
CN2-20	G/B	· Engine water temperature sensor · Discharge temperature sensor · Common of fuel sending unit	Grounding

3. Electric System

(3) List of CN3 terminal functions (8 pins)

Pin No.	Line color	Connection	Function
CN3-1	Y/G	Regulator secondary pressure sensor	Grounding
CN3-2	Y/W	Regulator secondary pressure sensor Vout terminal	Detection of regulator secondary pressure.
CN3-3	B/L	Engine controller (ECU) CN5-62 terminal	Grounding
CN3-4	—	NIL	
CN3-5	Y/R	Regulator secondary pressure sensor Vcc terminal	Power supply (DC5V)
CN3-6	—	NIL	
CN3-7	R/B	Engine controller (ECU) CN5-43 terminal	It supplies power (DC5V) to engine controller (ECU) acceleration sensor circuit.
CN3-8	R/W	Engine controller (ECU) CN5-61 terminal	<ul style="list-style-type: none"> • It controls regulator second stage pressure voltage conversion value and engine speed is controlled between full load and unload revolution speed. • During manual regeneration (regeneration lamp lights continuously) engine speed is controlled to approximately 2,200 min⁻¹. ● Unload : DC0.7V(1,350 min⁻¹) ● Full load : DC3.0V(3,000 min⁻¹)

3. Electric System

DPF controller

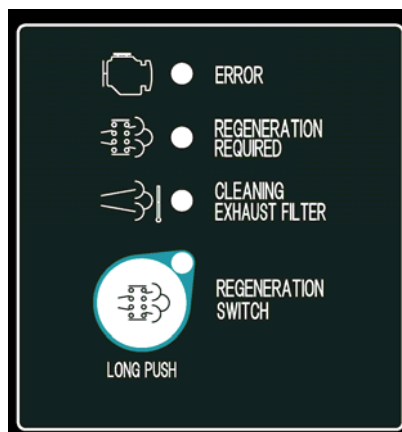

A130992

(4) List of CN19 terminal functions (8 pins)

Pin No.	Line color	Connection	Function
CN19-1	L/B	Error lamp	When abnormality occurs to engine or excessive soot is accumulated, electricity is supplied to DPF controller from engine controller (ECU) to make error lamp light on. For the details of error, trouble diagnosis tool (SA-D) is connected to check them. SA-D: SMARTASSIST-Direct See 4.6 Engine Trouble Diagnosis Function.
CN19-2	Br	Regeneration required lamp	DPF regeneration required lamp. When the soot accumulated on DPF can not be automatically regenerated, lamp lights to require manual regeneration.
CN19-3	Br/B	Cleaning exhaust filter lamp	DPF cleaning exhaust filter lamp. It lights on when automatic regeneration is performed due to accumulation of soot at DPF.
CN19-4	Br/R	Regeneration lamp	When manual regeneration is required, it makes regeneration lamp flicker. During manual regeneration the lamp changes from flickering to lighting.
CN19-5	R/W	Engine controller (ECU) CN5-51 terminal	Power supply (DC12V)
CN19-6	R/W	Emergency controller CN1-4 terminal	Power supply (DC12V)
CN19-7	Br/W	Regeneration switch	DPF regeneration switch. It is to start DPF manual regeneration.
CN19-8	Br/R	Emergency controller CN2-2 terminal	During manual regeneration operation, enforced signal is transmitted to emergency controller CN2-2 terminal to enable enforced purge operation.

3. Electric System

3.3 Engine Controller (ECU)

Part number:46870 64400

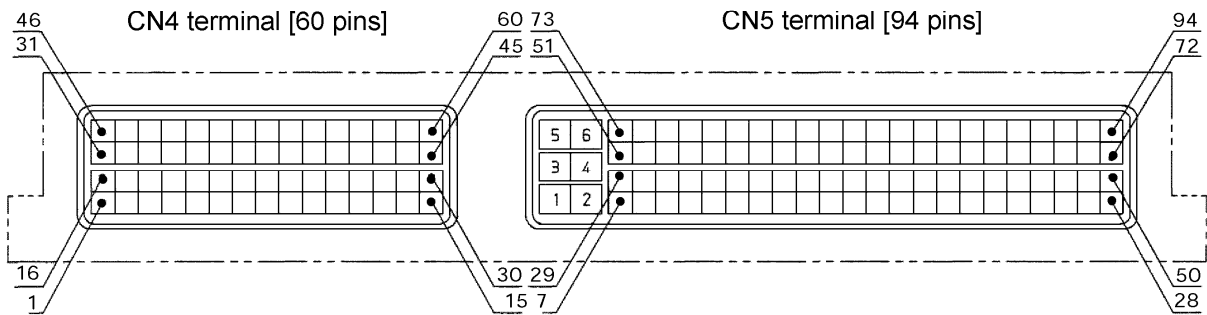
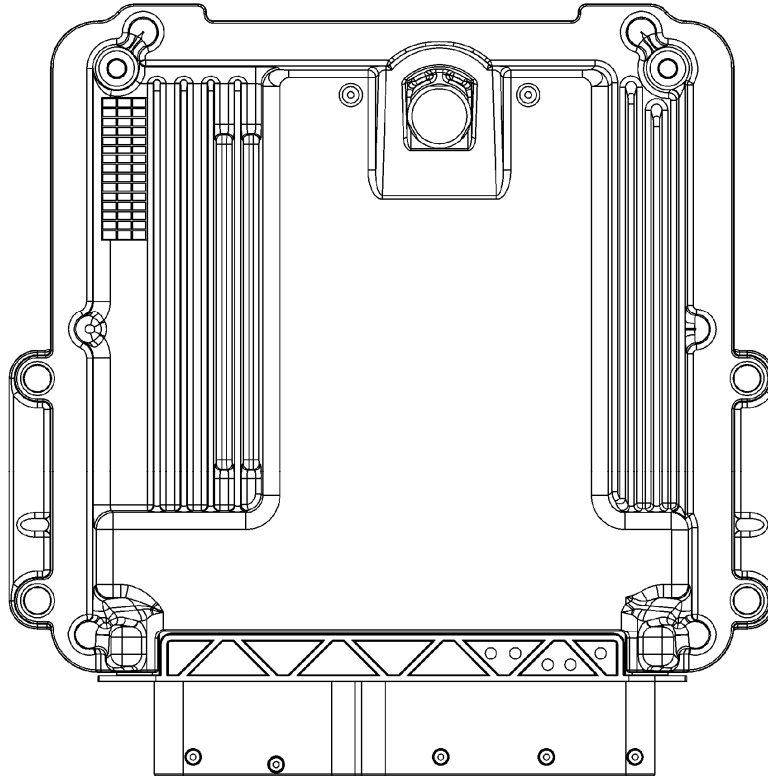

PC14021E

3. Electric System

(1) List of CN4 terminal functions (60 pins)

Pin No.	Line color	Connection	Function
CN4-1	L	Injector 2	Injects fuel to injector 2.
CN4-2	G/Y	Injector 3	Injects fuel to injector 3.
CN4-3	—	NIL	
CN4-4	Y	Supply pump	When power stays on, fuel is sent to common rail by pressure.
CN4-5	L	Supply pump	Fuel injection volume to common rail is controlled by control of power supply timing.
CN4-6	—	NIL	
CN4-7	R	Rail pressure sensor 5Vs terminal	Power supply (DC5V)
CN4-8	P	Cam speed sensor 5Vs terminal	
CN4-9	—	NIL	
CN4-10	—	NIL	
CN4-11	Y/B	Fuel temperature sensor	It detects fuel temperature. It detects the voltage which changes upon resistance value, and counts the fuel temperature and it is used to control supply pump.
CN4-12	SB	DPF differential pressure sensor	It detects the pressure at the high pressure side of DPF and then it uses it for after-treatment.
CN4-13	—	NIL	
CN4-14	—	NIL	
CN4-15	—	NIL	
CN4-16	Y	Injector 4	Injects fuel to injector 4.
CN4-17	G/R	Injector 1	Injects fuel to injector 1.
CN4-18	—	NIL	
CN4-19	W/G	Intake throttle valve	Power supply for throttle valve motor (DC+)
CN4-20	B/G	Intake throttle valve	Power supply for throttle valve motor (DC-)
CN4-21	—	NIL	
CN4-22	—	NIL	
CN4-23	—	NIL	
CN4-24	—	NIL	
CN4-25	B/W	Rail pressure sensor GND terminal	Grounding
CN4-26	P/B	Rail pressure sensor PRAIL terminal	It detects rail pressure (fuel pressure). It detects fuel pressure in rail and it converts it voltage signal and inputs it. It is used for fuel injection control.
CN4-27	—	NIL	
CN4-28	L	Water temperature sensor	It detects engine coolant temperature for low temperature start control and EGR control.
CN4-29	L/O	Water temperature sensor GND terminal	Grounding
CN4-30	—	NIL	
CN4-31	P	Injector 2	Injects fuel to injector 2.
CN4-32	G/W	Injector 3	Injects fuel to injector 3.
CN4-33	O	Injector 4	Injects fuel to injector 4.
CN4-34	—	NIL	
CN4-35	—	NIL	

3. Electric System

Pin No.	Line color	Connection	Function
CN4-36	—	NIL	
CN4-37	W/L	Cam speed sensor OUT terminal	ECU judges cylinder according to (CSS) signal, and it decides engine speed and piston position.
CN4-38	—	Crank speed sensor shield	Noise prevention
CN3-39	W	Crank speed sensor	ECU judges cylinder according to (CSS) signal, and it decides engine speed and piston position.
CN4-40	—	NIL	
CN4-41	—	NIL	
CN4-42	—	NIL	
CN4-43	—	NIL	
CN4-44	—	NIL	
CN4-45	—	NIL	
CN4-46	—	NIL	
CN4-47	G/O	Injector 1	Injects fuel to injector 1.
CN4-48	—	NIL	
CN4-49	—	NIL	
CN4-50	—	NIL	
CN4-51	B/O	Fuel temperature sensor GND terminal	Grounding
CN4-52	B/R	Cam speed sensor GND terminal	Grounding
CN4-53	—	NIL	
CN4-54	O	Crank speed sensor OUT terminal	ECU judges cylinder according to (CSS) signal, and it decides engine speed and piston position.
CN4-55	—	NIL	
CN4-56	—	NIL	
CN4-57	—	NIL	
CN4-58	—	NIL	
CN4-59	Br/R	Intake air temperature sensor	Use the EGR control for reduction of exhaust gas.
CN4-60	—	NIL	

3. Electric System

(2) List of CN5 terminal functions (96 pins)

Pin No.	Line color	Connection	Function
CN5-1	R	20A fuse	Power supply
CN5-2	B	Grounding	
CN5-3	R	20A fuse	Power supply
CN5-4	B	Grounding	
CN5-5	R	20A fuse	Power supply
CN5-6	B	Grounding	
CN5-7	—	NIL	
CN5-8	—	NIL	
CN5-9	—	NIL	
CN5-10	—	NIL	
CN5-11	—	NIL	
CN5-12	—	NIL	
CN5-13	—	NIL	
CN5-14	—	NIL	
CN5-15	—	NIL	
CN5-16	—	NIL	
CN5-17	—	NIL	
CN5-18	Br/W	Regeneration switch	DPF regeneration switch. It is to start DPF filter regeneration.
CN5-19	—	NIL	
CN5-20	W/Y	Intake throttle valve	Air suction can be performed in accordance with engine speed and load.
CN5-21	L/B	New temperature sensor	Grounding
CN5-22	—	NIL	
CN5-23	W/R	Intake throttle valve	Power supply (DC5V)
CN5-24	V	DPF differential pressure sensor	Power supply (DC5V)
CN5-25	Br	Regeneration required lamp	DPF regeneration required lamp. When the soot accumulated on DPF can not be automatically regenerated, lamp lights to require regeneration.
CN5-26	—	NIL	
CN5-27	—	NIL	
CN5-28	B/G	Starter relay (R3) exciting coil	When ECU CN5-35 terminal is electrified with starter switch placed on start position, CN5-28 terminal inner contact becomes ON and starter relay (R3) coil is electrified to enable starter to drive. When engine speed becomes more than 675 min ⁻¹ , electrification becomes OFF. When starter is continuously electrified for 30 seconds, and electrification becomes OFF, and it is prohibited to electrify for 30 seconds.
CN5-29	—	NIL	
CN5-30	—	NIL	
CN5-31	—	NIL	
CN5-32	B/R	Emergency controller CN1-5 terminal	When emergency controller Ry4 relay becomes ON, abnormality signal is sent to ECU to stop engine.
CN5-33	Br/W	EGR gas temperature sensor	EGR valve control.

3. Electric System

Pin No.	Line color	Connection	Function
CN5-34	—	NIL	
CN5-35	W	Starter switch C terminal via emergency controller	Inputting start signal.
CN5-36	—	NIL	
CN5-37	—	NIL	
CN5-38	—	NIL	
CN5-39	W/G	EGR pressure sensor (Intake Vout terminal)	EGR valve control.
CN5-40	—	NIL	
CN5-41	—	NIL	
CN5-42	—	NIL	
CN5-43	R/B	Emergency controller CN3-7 terminal	It supplies power (DC5V) to engine controller (ECU) acceleration sensor circuit.
CN5-44	—	NIL	
CN5-45	R/G	EGR pressure sensor	Power supply (DC5V)
CN5-46	—	NIL	
CN5-47	—	NIL	
CN5-48	—	NIL	
CN5-49	—	NIL	
CN5-50	L/Y	Emergency controller CN2-12 terminal	When preheating, preheat signal is sent to emergency controller CN2-12 terminal to make preheat lamp ON.
CN5-51	R/W	DPF controller CN19-5 terminal	Power supply (DC12V)
CN5-52	W/B	Intake throttle valve	Grounding
CN5-53	O	SA-D "SMARTASSIST-Direct" No.3 terminal	Trouble diagnosis tool connection terminal (CAN communication)
CN5-54	Br	EGR valve	It operates EGR DC motor, and it controls valve lift of EGR valve. ECU decides EGR gas volume based on engine speed and engine load ratio (fuel injection volume) and it operates EGR valve by EGR DC motor, and also it controls EGR gas volume to be mixed in engine intake air.
CN5-55	—	NIL	
CN5-56	P/L	Exhaust manifold temperature sensor	Use the EGR control for reduction of exhaust gas.
CN5-57	—	NIL	
CN5-58	—	NIL	
CN5-59	—	NIL	
CN5-60	—	NIL	
CN5-61	R/W	Emergency controller CN3-8 terminal	It controls regulator second stage pressure voltage conversion value and engine speed is controlled between full load and unload revolution speed. ●Unload : DC0.7V(1,350 min ⁻¹) ●Full load : DC3.0V(3,000 min ⁻¹)
CN5-62	B/L	Emergency controller CN3-3 terminal	Grounding
CN5-63	V/W	DPF differential pressure sensor	It detects the pressure at the high pressure side of DPF and then it uses it for after-treatment.

3. Electric System

Pin No.	Line color	Connection	Function
CN5-64	—	NIL	
CN5-65	O/B	SA-D “SMARTASSIST-Direct” No.4 terminal	Grounding
CN5-66	Y	· Emergency controller CN2-11 terminal · Alternator L terminal	It detects deficiency of charging battery, and it enables alarm lamp ON.
CN5-67	—	NIL	
CN5-68	L/R	EGR valve relay exciting coil	Power supply (DC12V) of EGR valve relay exciting coil
CN5-69	Br/B	Cleaning exhaust filter lamp	When soot is so much accumulated on DPF that cleaning is required, it lights on while cleaning is performed.
CN5-70	L/G	Glow plug relay exciting coil	No power exists during usual operation. Preheating begins when ECU CN5-88 terminal is electrified. Glow plug relay coil is electrified to start preheating.
CN5-71	Br/R	Regeneration lamp	When manual regeneration is required, it makes regeneration lamp flicker. During manual regeneration the lamp changes from flickering to lighting.
CN5-72	—	NIL	
CN5-73	G/R	Starter relay exciting coil	Power supply (DC12V)
CN5-74	P/B	EGR pressure sensor No.4 terminal	Grounding
CN5-75	O/L	SA-D “SMARTASSIST-Direct” No.2 terminal	Trouble diagnosis tool connection terminal (CAN communication)
CN5-76	Br/B	EGR valve DC motor	It operates EGR DC motor, and it controls valve lift of EGR valve. ECU decides EGR gas volume based on engine speed and engine load ratio (fuel injection volume) and it operates EGR valve by EGR DC motor, and also it controls EGR gas volume to be mixed in engine intake air.
CN5-77	Gy/B	DPF differential pressure sensor	Grounding
CN5-78	—	NIL	
CN5-79	L/R	New temperature sensor	
CN5-80	Gy/R	DPF intermediate temperature sensor	DPF temperature needed for the post processing system, are measured.
CN5-81	V/Y	DPF inlet temperature sensor	
CN5-82	—	NIL	
CN5-83	—	NIL	
CN5-84	—	NIL	
CN5-85	G/R	EGR pressure sensor (Exhaust Vout terminal)	EGR valve control.
CN5-86	—	NIL	
CN5-87	—	NIL	
CN5-88	R/Y	Starter switch BR terminal Alternator IG terminal	It senses that starter switch is turned ON, and it preheats according to coolant temperature time, and electrifies it to preheat.
CN5-89	—	NIL	

3. Electric System

Pin No.	Line color	Connection	Function
CN5-90	O	SA-D "SMARTASSIST-Direct" No.1 terminal	Power supply (DC12V)
CN5-91	—	NIL	
CN5-92	L/B	Error lamp	When engine fails or too much soot is accumulated on DPF, DPF controller CN19-1 terminal is electrified to light the lamp ON. For the details of error, trouble diagnosis tool (SA-D) is connected to check them. SA-D: SMARTASSIST-Direct See 4.6 Engine Trouble Diagnosis Function.
CN5-93	—	NIL	
CN5-94	Y/R	Emergency controller CN2-8 terminal	It outputs engine speed. ● Revolution ratio (pulse type) : 6 pulses per 1 revolution

Not for Reproduction

3. Electric System

3.4 Alternator

YANMAR part number:129423-77200

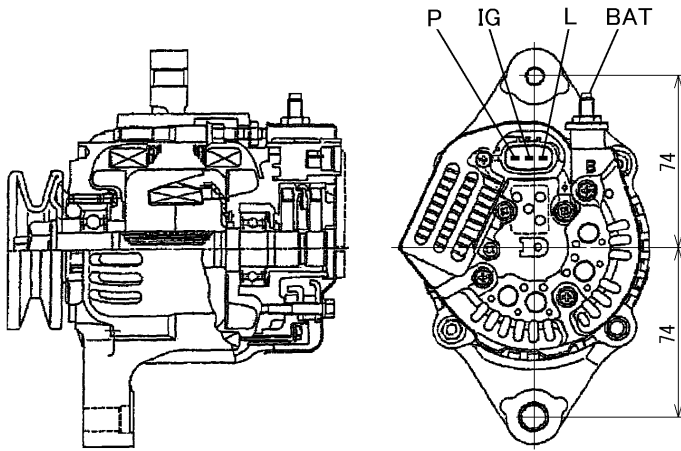

PC10028-1

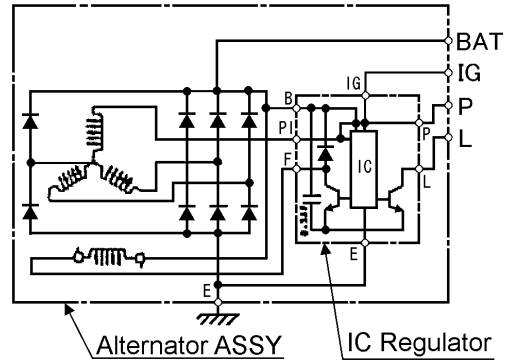

Internal wiring diagram

PC10057E

Nominal capacity	DC12V-40A
------------------	-----------

(1) List of functions

Pin No.	Line color	Connection	Function
BAT	Y	Starter motor B terminal	Power for charging voltage.
IG	R/Y	Starter switch BR terminal	It detects battery voltage, and it controls rotor coil electromagnetic current.
L	Y	Emergency controller CN2-11 terminal	It makes warning lamp go on when battery charging function is abnormal.
E	—	Grounding	Grounding

(2) Judgement of alternator functions

Checking method by voltage measurement	Normal value
Measure the battery terminal voltage at rated speed.	DC14.5±0.3V

3. Electric System

(3) Check and confirm the following when faulty charging warning lamp lights on

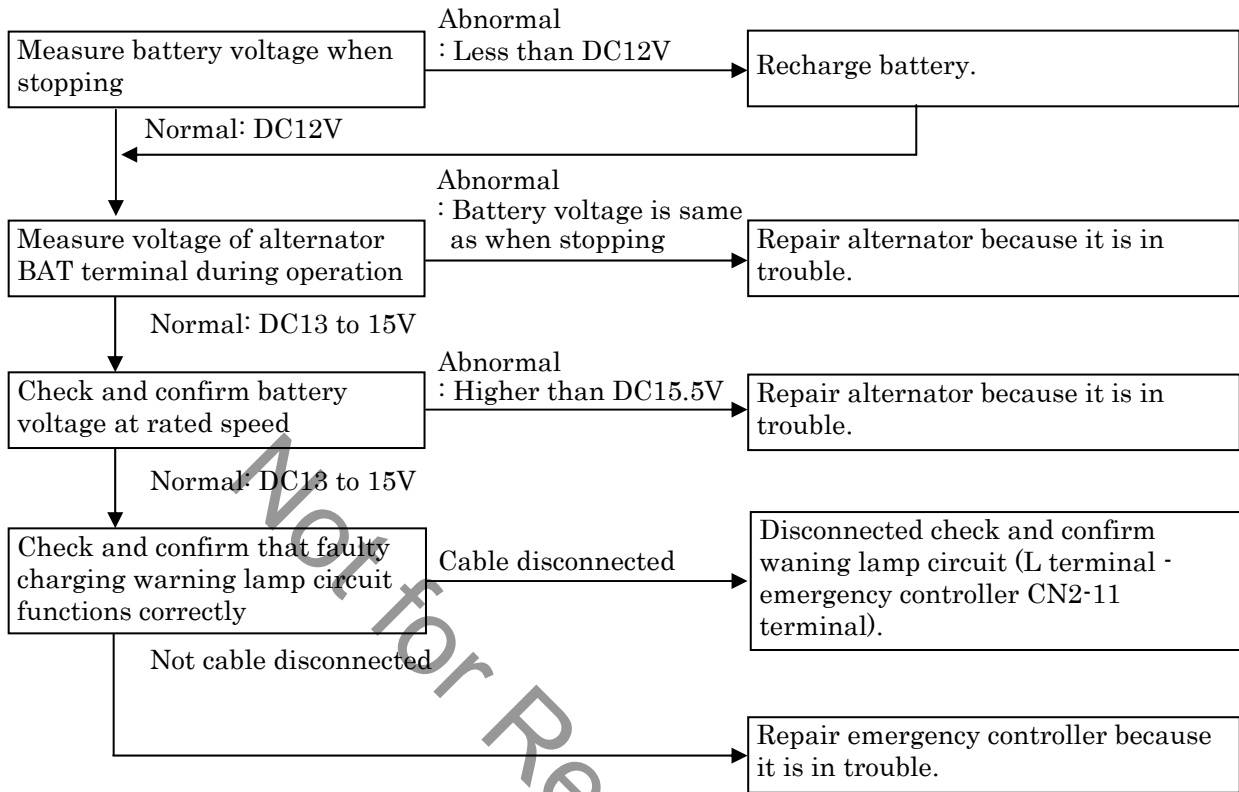

3. Electric System

3.5 Starter

YANMAR part number:129242-77010

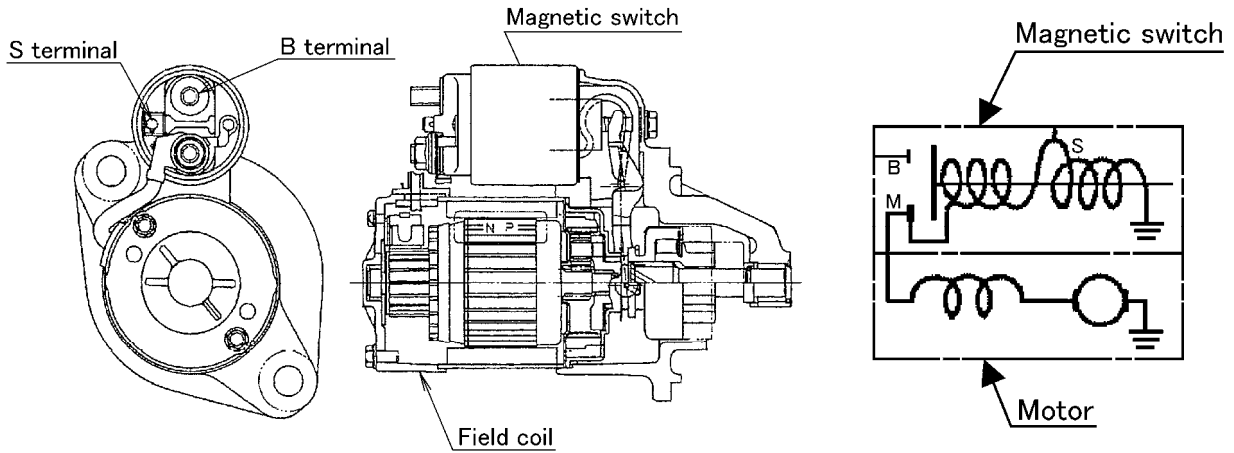

PC10036E

Internal wiring diagram

PC10030E

Voltage	DC12V
Output	1.7kW

(1) List of functions

Pin No.	Line color	Connection	Function
B	B	Battery + terminal	For supplying power to starter which enables starter pinion to turn.
S	W	Starter relay No.3 terminal	For supplying power to make starter pinion to spring out and also a little power to make pinion turn for smooth engagement between pinion gear and ring gear when they are in contact.

3. Electric System

3.6 Starter / Glow Plug Relay

Part number:44346 16600

YANMAR part number:129927-77920

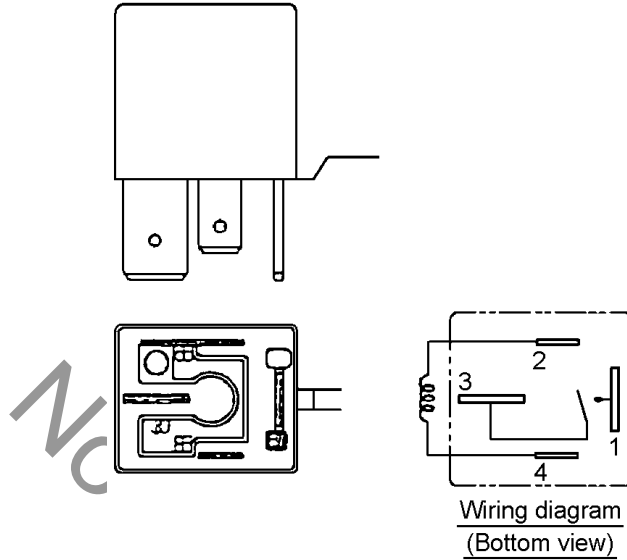

PC14024E

(1) Specification

Rated voltage	DC12V
Coil resistance (at 20°C)	103 Ω ± 10%
Rated control capacity	50A 14VDC Resistance load. (at 85°C)

(2-1) Starter relay functions list

Pin No.	Line color	Connection	Function
1	R	Starter B terminal	Power supply circuit to drive starter pinion
2	G/R	Engine controller (ECU) CN5-73 terminal	Power supply circuit for starter relay coil
3	W	Starter magnet switch S terminal	Power supply circuit to drive starter pinion
4	B/G	Engine controller (ECU) CN5-28 terminal	When engine controller (ECU) senses engine start by charge signal, the contact between CN5-28 and CN5-73 changes over OFF and electricity to starter S terminal is cut to stop starter.

(2-2) Glow plug relay functions list

Pin No.	Line color	Connection	Function
1	R/W	80A fuse	Power supply circuit to glow plug function
2	L/G	Engine controller (ECU) CN5-70 terminal	Electrification is made by engine controller (ECU) according to coolant temperature at start-up.
3	L	Glow plug	Power supply circuit to glow plug function
4	B	Grounding	

3. Electric System

3.7 EGR Valve Relay

Part number:44346 16500

YANMAR part number:198461-52950

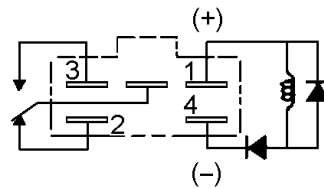
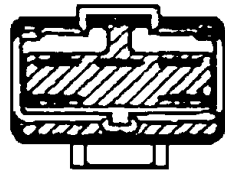
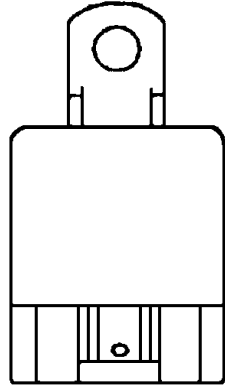

Wiring diagram (Bottom view)

PC14025E

(1) Specification

Rated voltage	DC12V	
Coil resistance (at 20°C)	30 Ω ± 10%	
Contact rating	Motor load	
	Halogen lamp load	20A

(2) List of functions

Pin No.	Line color	Connection	Function
1	L/R	Engine controller (ECU) CN5-68 terminal	Power supply circuit for EGR valve relay exciting coil
2	R/L	20A fuse	Power supply circuit for EGR valve
3	Y/R	EGR valve	
4	B	Grounding	

3. Electric System

3.8 Solenoid Valve (SV1) for Starting Unloader and Purge / Solenoid Valve (SV2) for Aftercooler Drain: Option

Part number:46811 30000

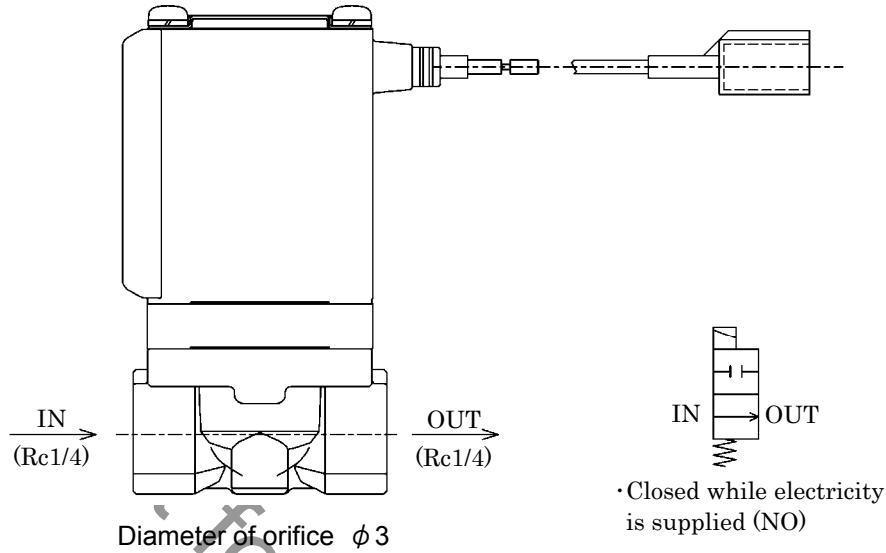

(1) Specification

Rated voltage	DC12V
---------------	-------

(2) List of functions

For details of functions, see “(1) List of CN1 terminal functions (CN1-7 terminal) of 3.2.1 Emergency controller” .

3.9 Engine Oil Pressure Switch (for emergency stops)

YANMAR part number:119761-39450

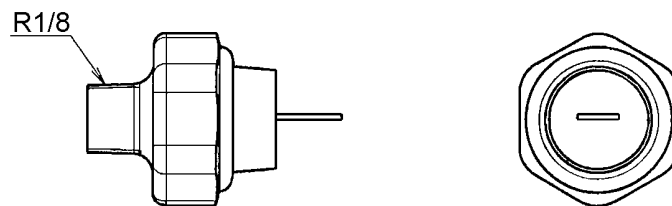

PC14028

(1) Specification

Setting pressure	7.1psi(0.049MPa)[0.49bar]
Contact type	B contact switch (Contact “OFF” in excess of set pressure)
Time lag	<ul style="list-style-type: none"> ·20 seconds after engine starts ·2 seconds during operation ※

※When such situation under operation pressure continues longer than 2 seconds it brings engine to emergency stop.

3. Electric System

3.10 Fuel Air-bleeding Electromagnetic Pump

Part number:43650 02700
 YANMAR part number:129612-52100

(1) Specification

Rated voltage	DC12V
Operating current	1.5A (MAX)
Delivery capacity	More than 0.11 to 0.29gal/min (0.4 to 1.1 L/min)

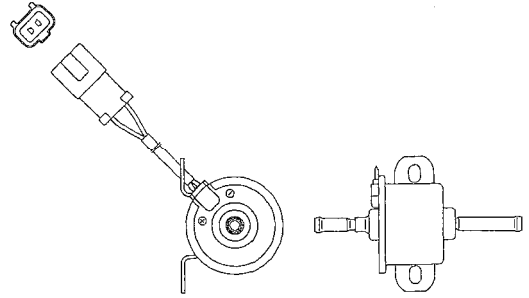

PC10014

3.10 Discharge Temperature Sensor / Water Temperature Sensor

Part number:44364 08200

※Water temperature sensor is used for temperature indication, warning/emergency indication lamp and emergency stop.

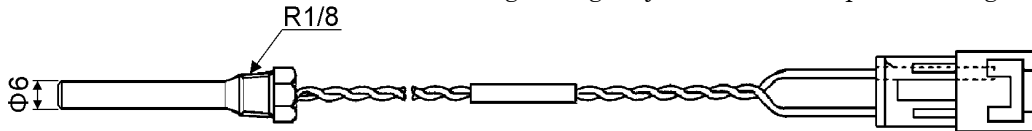

PC08033

《Note》 Take care not to tighten excessively. Less than 17.7lbf·in.(2N·m)[20kgf·cm]

Characteristic of temperature · resistance

Temperature °F(°C)	Resistance value (Ω)	Permissible value (%)	Temperature °F(°C)	Resistance value (Ω)	Permissible value (%)
68(20)	11,620	±10	176 (80)	1,300	±6
95(35)	6,270	±9	203 (95)	840	±5
122(50)	3,560	±8	230(110)	560	±4
149(65)	2,120	±7	239(115)	490	±4

3. Electric System

3.12 Pressure Sensor (for intake negative pressure / service pressure and regulator secondary pressure)

Part number:44328 20600

Trouble diagnosis of pressure sensor itself

Check and confirm that output voltage between ②-③ is $0.5 \pm 0.1V$ when DC5V is applied between ①-③ terminals at an atmospheric pressure.

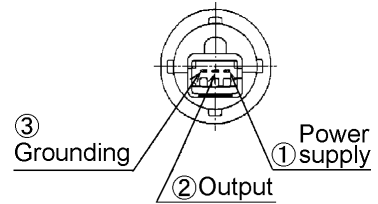

Pressure and output voltage(for reference only)

Electric wire	Signal
①VCC	Power supply (DC5V)
②VOUT	Output
	Pressure 0psi (0MPa) [0bar] DC0.5V
	Pressure 14psi (0.1MPa) [1bar] DC0.9V
	Pressure 85psi (0.6MPa) [6bar] DC2.9V
	Pressure 100psi (0.69MPa) [6.9bar] DC3.3V
Pressure 142psi (0.98MPa) [9.8bar] DC4.5V	
③GND	Grounding

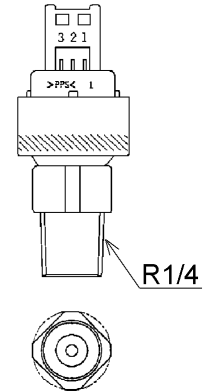

PC14029E

3.13 Fuel Meter (Display)

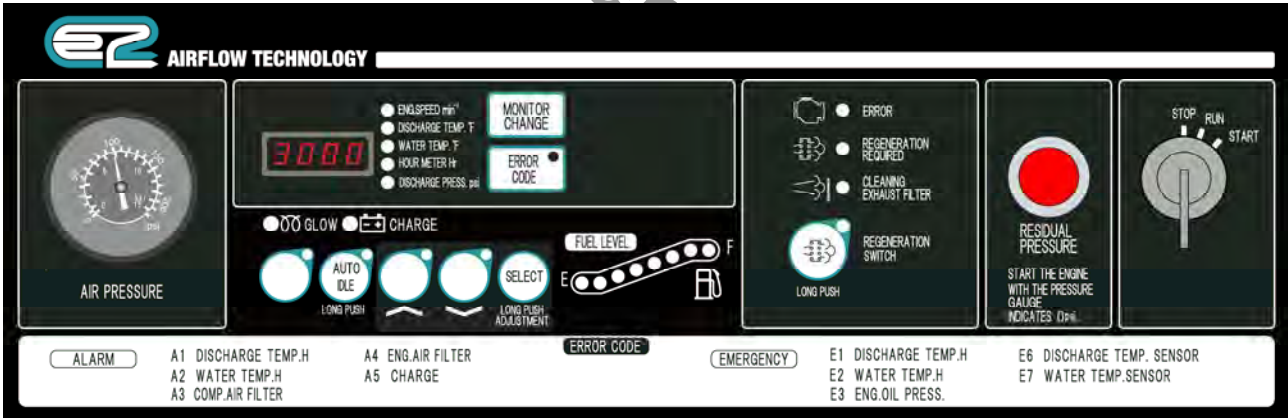

A130957

Relation between indicator lamp (LED) and residual fuel level

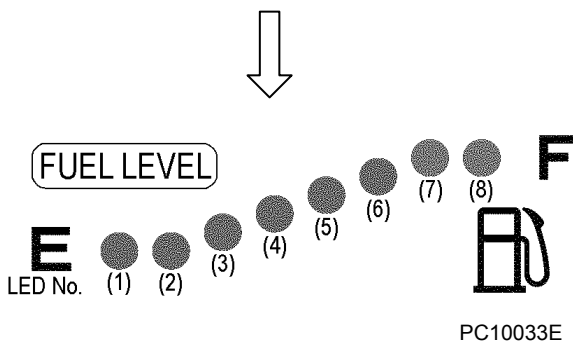

Indicator lamp		Residual fuel gal.(L)	Remark
LED No.1	Blinking (Red)	4.2(17)	E
LED No.2	ON (Red)	6.1(26)	
LED No.3	ON (Green)	7.9(33)	
LED No.4	ON (Green)	10.6(42)	1/2
LED No.5	ON (Green)	13.2(54)	
LED No.6	ON (Green)	15.1(63)	
LED No.7	ON (Green)	17.7(72)	
LED No.8	ON (Green)	19.8(82)	
Full tank		23.8(90)	F

PC10033E

3. Electric System

3.14 Sending Unit

Part number:36159 04100

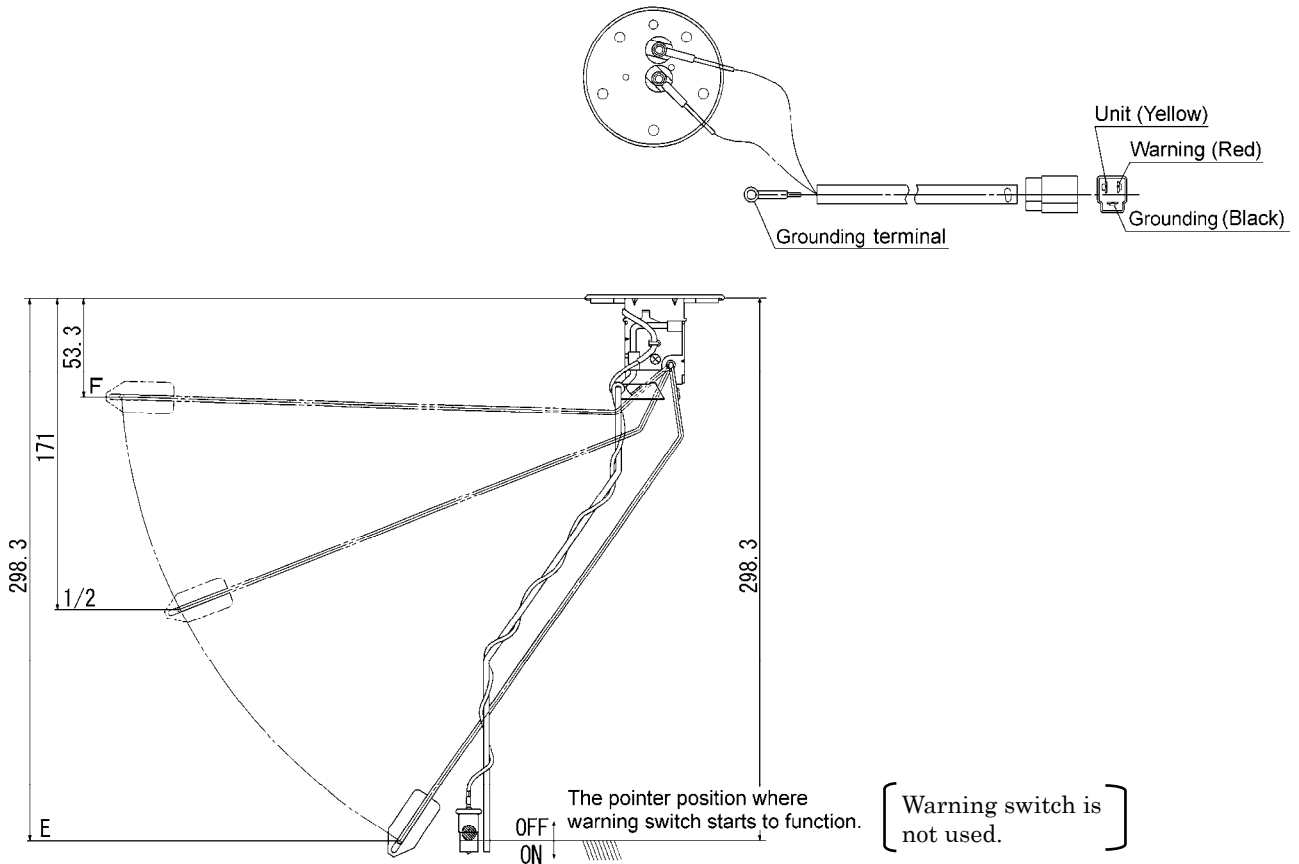

PC08037E-1

Float position	Resistance value (Ω)
E	110.0 ± 7.0
1/2	32.5
F	3.0 ± 2.0

3.15 Air filter Differential Pressure Switch

Part number:32148 03000

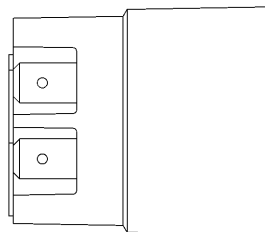
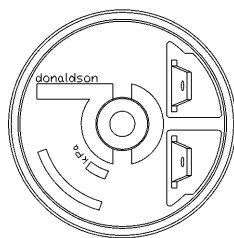

- Operating pressure : 6.2kPa
- A Contact

SC10016

3. Electric System

3.16 Electronic Control Engine Component

[Excerpted from YANMAR SERVICE MANUAL]

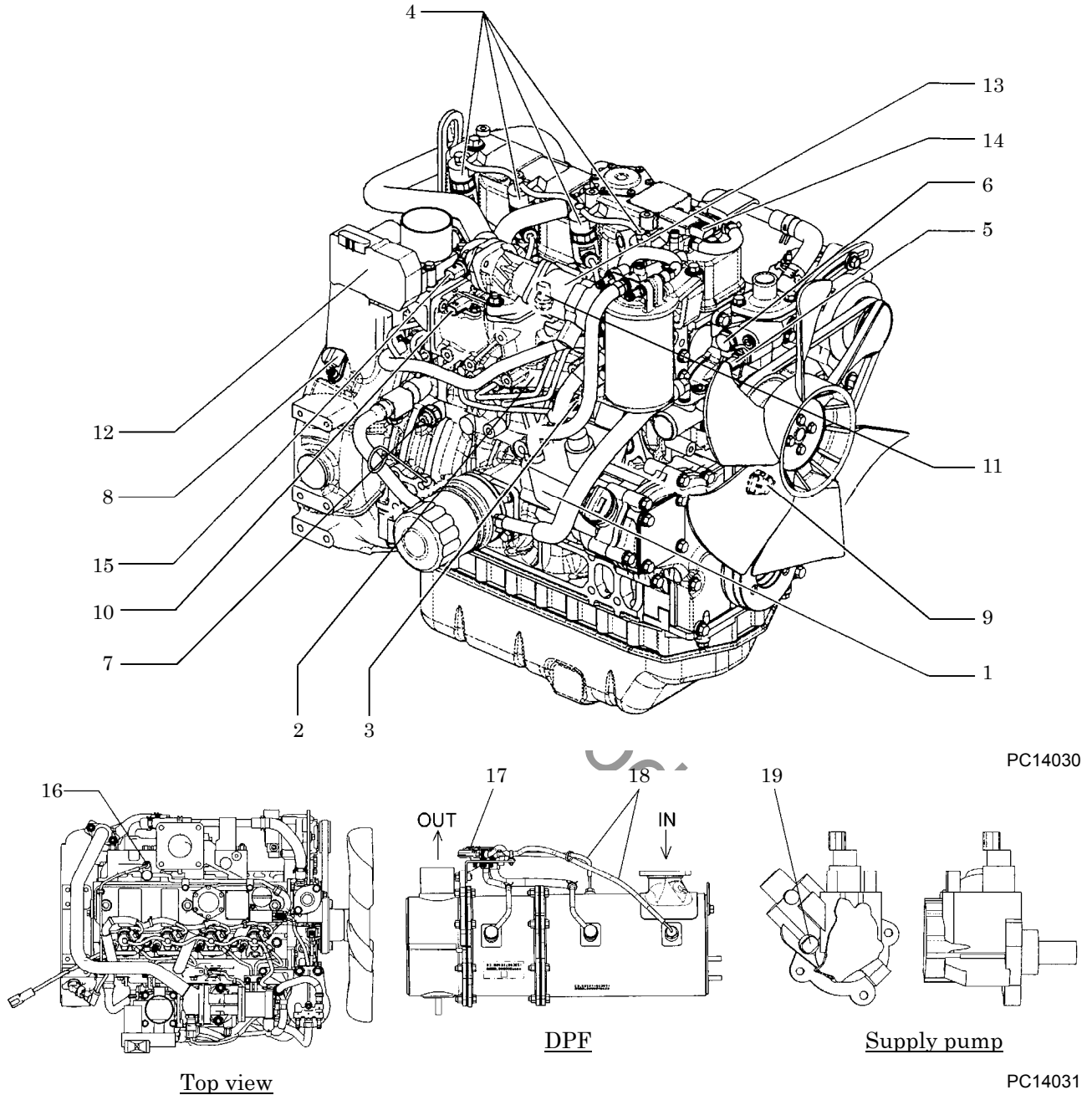

- | | | |
|-------------------------------------|-----------------------------------|---|
| 1. Supply pump | 7. Engine oil pressure switch | 14. EGR (Intake/Exhaust) pressure sensor |
| 2. Rail | 8. Crank speed sensor | 15. EGR gas temperature sensor |
| 3. Rail pressure sensor | 9. Cam speed sensor | 16. Exhaust manifold temperature sensor |
| 4. Injector | 10. New air temperature sensor | 17. Diesel particulate filter (DPF) differential pressure sensor |
| 5. Water temperature sensor (ECU) | 11. Intake air temperature sensor | 18. Diesel particulate filter (DPF) intermediate/inlet temperature sensor |
| 6. Water temperature sensor (Gauge) | 12. Intake air throttles | 19. Fuel temperature sensor |
| | 13. EGR valve | |

3. Electric System

3.16.1 Supply pump

The fuel passes the pre-filter and is pressure-fed by a fuel feed pump to the main filter, then it arrives at the supply pump. The ECU controls the opening of the intake metering valve and adjusts the fuel intake volume so that the rail pressure is at the target value. The fuel pressurized in the supply pump is fed to the rail.

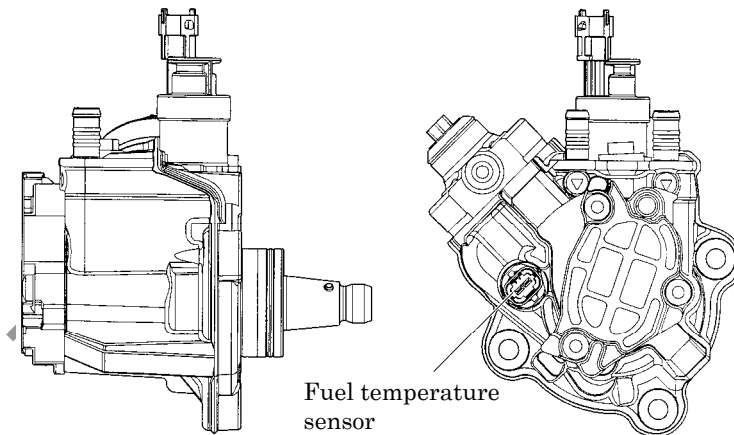

PC14032

3.16.2 Rail

A pressure of up to 160MPa is accumulated in the rail. The rail is equipped with a rail pressure sensor and it sends information to the ECU. In the case of an abnormal increase in the rail pressure, the mechanical relief valve opens to prevent the pressure increase.

3.16.3 Rail pressure sensor

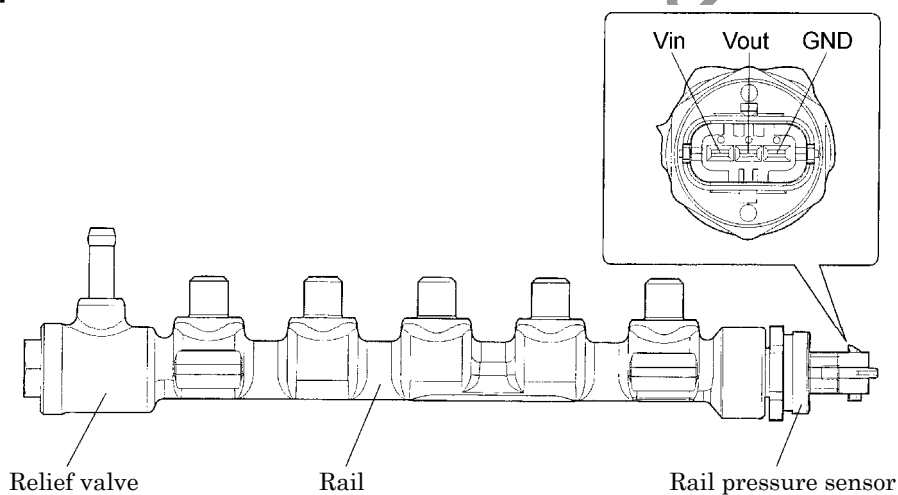

PC14033

YANMAR part number (Rail ASS'Y):129A00-57000

※Do not replace the rail pressure sensor and relief valve.

If it is damaged, replace it as rail assembly.

3. Electric System

3.16.4 Injector

The ECU controls the injector to maintain optimum injection volume and injection timing and injects the high pressure fuel accumulated in the rail into the cylinder.

Each piece of injector has its correction data for improvement of injection volume accuracy. The correction data are printed at the top of each injector, and are written in ECU. The injection volume is corrected based on the data. Therefore, it is necessary to write the data again when injector and ECU are replaced. Further, take care not to touch any cable at key on because high volt current flows to injector.

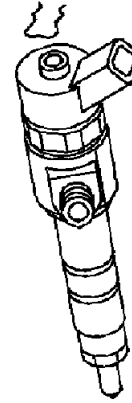

PC14034

3.16.5 Water temperature sensor (ECU)

Allows the CSD (Cold start device) and EGR (Exhaust gas recirculation) to be controlled in engine cold-start conditions. Make sure to use genuine parts and never use it for other equipment.

YANMAR part number: 129927-44900

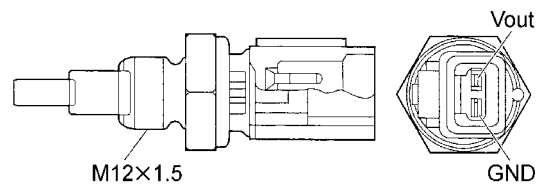

PC14035

Installation

 : $194.7 \pm 17.7 \text{ lbf} \cdot \text{in.}$ ($22 \pm 2 \text{ N} \cdot \text{m}$) [$224 \pm 20 \text{ kgf} \cdot \text{cm}$]

Coolant temperature °F(°C)	Resistance value (kΩ)
68(20)	$2.45^{+0.14}_{-0.13}$
176(80)	0.318 ± 0.008
212(100)	(0.1836)

3.16.6 Water temperature sensor (Gauge)

See 3.11 Discharge Temperature Sensor / Water Temperature Sensor.

3.16.7 Engine oil pressure switch

See 3.9 Engine Oil Pressure Switch.

3. Electric System

3.16.8 Crank speed sensor

The crank speed sensor is equipped on the flywheel side and the cam speed sensor is equipped on the gear side. Based on these 2 sensor outputs, the ECU recognizes the engine speed and each piston position.

YANMAR part number:129A00-21710

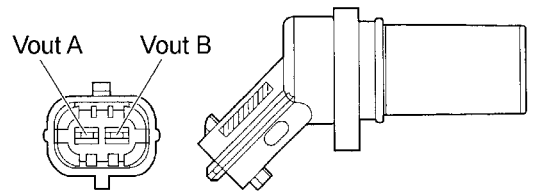

PC14036

Installation

 : $70.8 \pm 17.7 \text{ lbf} \cdot \text{in.}$ ($8 \pm 2 \text{ N} \cdot \text{m}$) [$82 \pm 20 \text{ kgf} \cdot \text{cm}$]

3.16.9 Cam speed sensor

The crank speed sensor is equipped on the flywheel side and the cam speed sensor is equipped on the gear side. Based on these 2 sensor outputs, the ECU recognizes the engine speed and each piston position.

YANMAR part number:129A00-14710

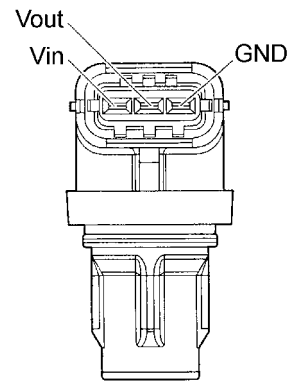

PC14037

Installation

 : $70.8 \pm 4.4 \text{ lbf} \cdot \text{in.}$ ($8 \pm 0.5 \text{ N} \cdot \text{m}$) [$82 \pm 5 \text{ kgf} \cdot \text{cm}$]

3.16.10 New air temperature sensor

This is used to control for optimizing fuel injection pattern depending on applied conditions.

YANMAR part number:129A00-12711

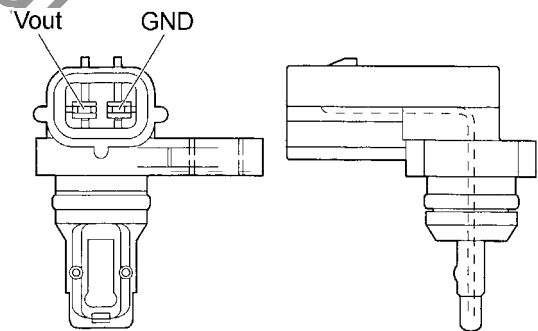

PC14038

Installation

 : $62.0 \pm 12.4 \text{ lbf} \cdot \text{in.}$ ($7 \pm 1.4 \text{ N} \cdot \text{m}$) [$71 \pm 14 \text{ kgf} \cdot \text{cm}$]

3.16.11 Intake air temperature sensor

YANMAR part number:129A00-12720

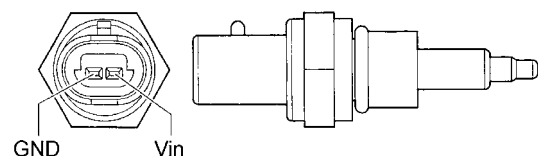

PC14039

Installation

 : $123.9 \pm 26.6 \text{ lbf} \cdot \text{in.}$ ($14 \pm 3 \text{ N} \cdot \text{m}$) [$142 \pm 31 \text{ kgf} \cdot \text{cm}$]

3. Electric System

3.16.12 Intake air throttles

YANMAR part number:129A00-12900

Installation

 : $79.7 \pm 15.9 \text{ lbf} \cdot \text{in.}$ ($9 \pm 1.8 \text{ N} \cdot \text{m}$) [$92 \pm 18 \text{ kgf} \cdot \text{cm}$]

Note:

Be sure to read the precautions before handling the intake throttle.

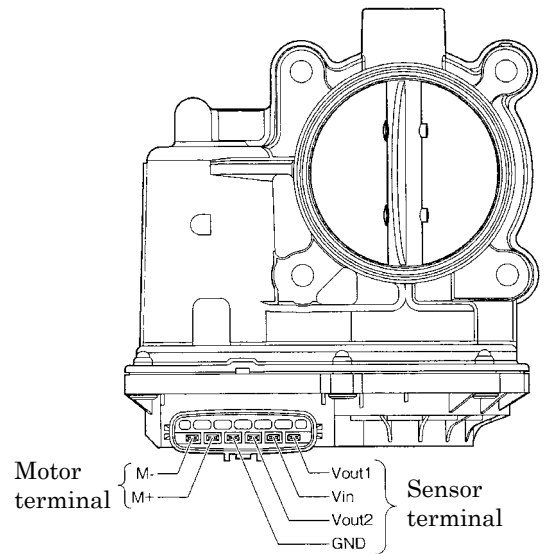

PC14040

The intake throttle is a device that controls the amount of the engine air intake. Use it for the combustion of soot collected inside the DPF. The intake throttle is driven by the DC motor. The ECU controls the appropriate degree of opening of the throttle depending on the engine speed and load conditions. Accordingly, the engine takes in the minimum required amount of air to increase the exhaust temperature and burn soot inside the DPF.

Precautions:

- Do not use a throttle after you have dropped it. Even if it appears okay on the outside, it may have internal damage.
- Do not apply excessive impact or load to the throttle.
- Do not touch the stop screw part, as it has already been adjusted.
- Prevent any foreign matter including oil, dust, and water droplets from entering the air passage part.
- Do not remove the sensor cover installation rivet.
- Consider static electricity and prevent static electric charge of the human body when handling the throttle.
- Do not touch the sensor cover terminal directly.
- Do not touch the throttle valve with your hands when the throttle is energized. Your hands may get pinched in the valve and get injured.
- Do not check operation with the installation surface of the throttle unit pointing down, as the valve protrudes from the installation surface.
- Prevent water and foreign matter from entering the connector connection part.

Characteristics of the intake throttle

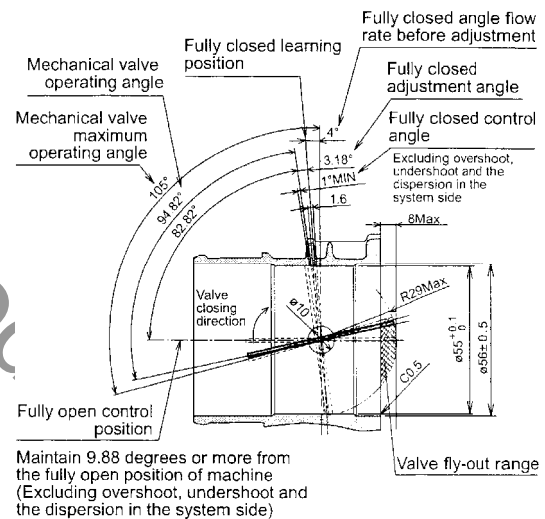

PC14041E

3. Electric System

3.16.13 EGR valve

Controls the exhaust gas recirculation flow rate depending on the engine speed / load signals from the ECU. It is installed on the top of the exhaust manifold.

YANMAR part number:129A00-13901

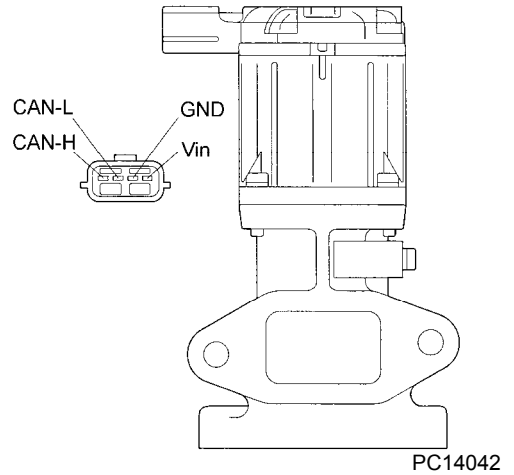

3.16.14 EGR (Intake/Exhaust) pressure sensor

EGR control for reduction of exhaust gas is implemented by EGR (Intake/Exhaust) pressure sensor, intake air temperature sensor, EGR gas temperature sensor and exhaust manifold temperature sensor.

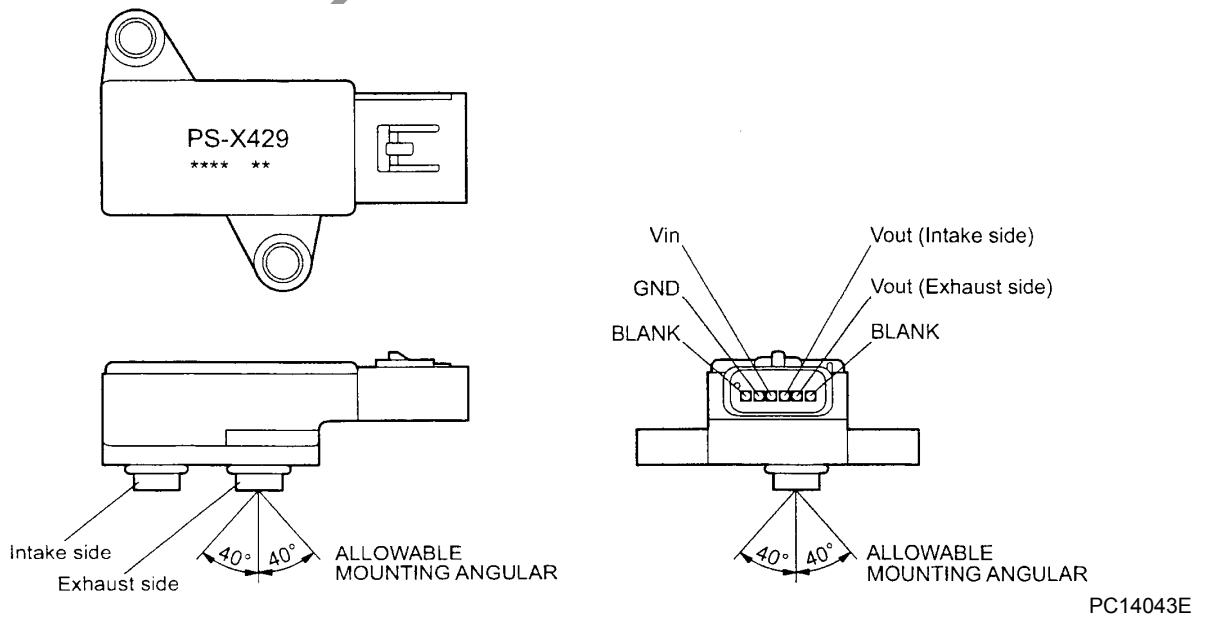

YANMAR part number:129978-12700

Installation

: $62.0 \pm 12.4 \text{ lbf} \cdot \text{in.}$ ($7 \pm 1.4 \text{ N} \cdot \text{m}$) [$71 \pm 14 \text{ kgf} \cdot \text{cm}$]

3.16.15 EGR gas temperature sensor

YANMAR part number:129A00-13751

Installation

: $123.9 \pm 26.6 \text{ lbf} \cdot \text{in.}$ ($14 \pm 3 \text{ N} \cdot \text{m}$) [$142 \pm 31 \text{ kgf} \cdot \text{cm}$]

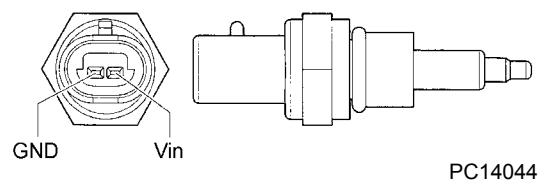

3. Electric System

3.16.16 Exhaust manifold temperature sensor

YANMAR part number:129A00-13770

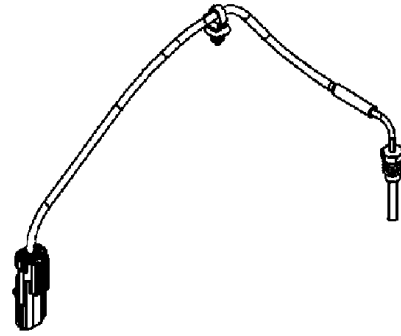

PC14045

3.16.17 Diesel particulate filter (DPF) differential pressure sensor

DPF differential pressure sensor, DPF intermediate/inlet temperature sensor are equipped together with throttle valve for DPF regeneration control. For the details of DPF regeneration control, refer to 3.1.4 clause.

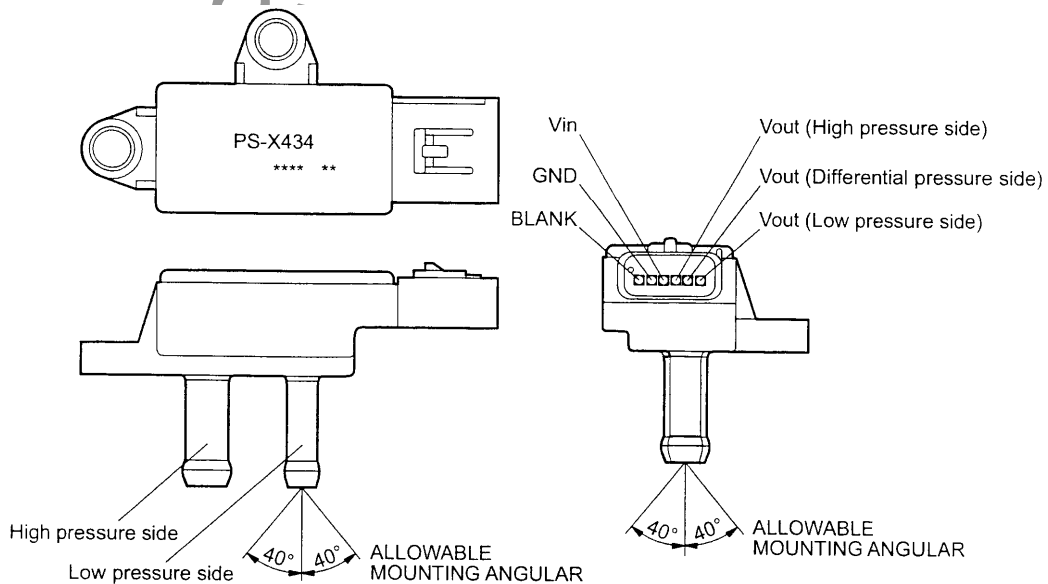

PC14046E

YANMAR part number:129978-17700

Installation

: $62.0 \pm 12.4 \text{ lbf} \cdot \text{in.}$ ($7 \pm 1.4 \text{ N} \cdot \text{m}$) [$71 \pm 14 \text{ kgf} \cdot \text{cm}$]

Note:

If you install a pipe to the DPF differential pressure sensor, do not install it as shown in the right figure. If water collects, the pressure cannot be detected.

Differential pressure sensor pipe installation (example)

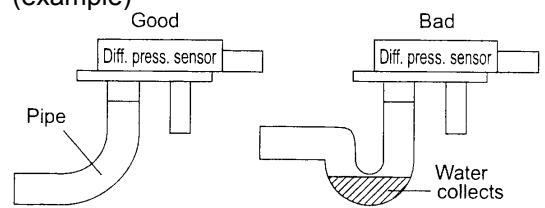

PC14047E

3. Electric System

3.16.18 Diesel particulate filter (DPF) intermediate/inlet temperature sensor

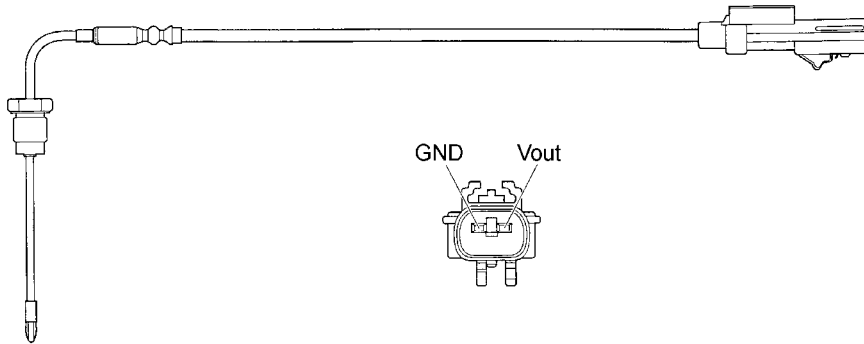

PC14048

YANMAR part number: DPF intermediate temperature sensor 129C00-13950

DPF inlet temperature sensor 129C00-13940

Installation

 : 221.3–354.0 lbf·in. (25–40 N·m) [255–410 kgf·cm]

Note:

Do not lift the DPF by holding the sensor part.

3.16.19 Fuel temperature sensor

It is installed to the supply pump, and the thermistor changes the resistance according to the temperature. The resistance is low when the fuel temperature is high, and is high when the temperature is low. The ECU energizes the voltage 5V to the fuel temperature sensor through pull up resistance, and calculates fuel temperature based on change of voltage to use for various controls such as supply pump control etc.

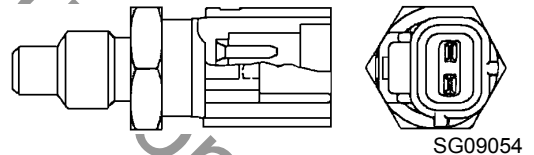

SG09054

Removal

Do not replace the fuel temperature sensor.

If it is faulty, replace it as supply pump assembly.

4. Troubleshooting

4.1 Repairing Procedures

When performing failure diagnosis, pay special attention to the followings, observing general cautions.

4.1.1 Safety caution

- (1) Removing such cap and/or plug for receiver tank, fuel tanks and pipes where pressure is loaded, stop the machine and relieve all the interior pressure. Install measuring instruments connected firmly.
- (2) When doing the job with co-worker(s) together, make sure to give signal to the other person(s) and do not allow other persons to come near to the job site.
- (3) Take care not to touch hot portions and not to be involved in turning portions.

4.1.2 Caution during failure diagnosis

- (1) Do not make haste to disassemble the unit

If the unit is disassembled urgently.

- ① You may disassemble the other portions which are not related with the trouble.
- ② The cause of trouble may be missing.

The unnecessary reparations require more spare parts and man-hours, and reparation costs will increase more. What is worse, you will lose reliance or trust from clients, operators and users.

Therefore, it is absolutely necessary to investigate the trouble more carefully in advance and to follow the required procedures for failure diagnosis.

- (2) Ask the clients about the trouble in details

In order to prevent misunderstanding and incorrect judgment about the trouble, it is necessary to ask users or operators about the following questions.

- ① Is there any other disorder than the trouble he has informed?
- ② Anything abnormal occurred before this trouble?
- ③ Did this trouble happen unexpectedly? Or the unit had been operated in bad conditions before?
- ④ When and how did this trouble occur?
- ⑤ Had he repaired the unit before this trouble occurred?
- ⑥ Did he not experience similar trouble before?

- (3) Inspection items before starting diagnosis

Sometimes such trouble may be caused owing to routine mishandling of the unit. Before starting failure diagnosis, check the following items.

- ① The engine runs short of engine oil or its oil is not dirty?
- ② Check each wire connection for any disconnection.
- ③ Check the other portions for any damage.

- (4) Confirmation of trouble

Discuss with user(s) and/or operator(s) sufficiently about the trouble. As a result, judge whether their judgment is based on the numerical comparison or sentimental basis. Make him (them) understand well the reparation or correction you have finished.

Then check and confirm by yourself the cause of the trouble.

Note) Never proceed any investigation or measurement which may cause further greater damage.

4. Troubleshooting

(5) Procedures of diagnosis

When you become well experienced, you can find out the cause easily during the process of confirmation (4). But easy understanding could cause unexpected failure. So check and judge it according to the following procedures.

- ① Check the easiest thing or portion first.
- ② Investigate the most possible cause.
- ③ Check the other things connected to the trouble.
- ④ Check for the possibility of any other troubles.
- ⑤ Start proper and careful investigation on this trouble.

(6) Prevention of repeated occurrence of similar trouble

Even if you have repaired the trouble, unless you get rid of the fundamental cause of the trouble, it will repeatedly occur. Therefore, perform full investigation of the trouble, and it is absolutely necessary to remove the basis of the trouble.

4.1.3 How to use the failure diagnosis

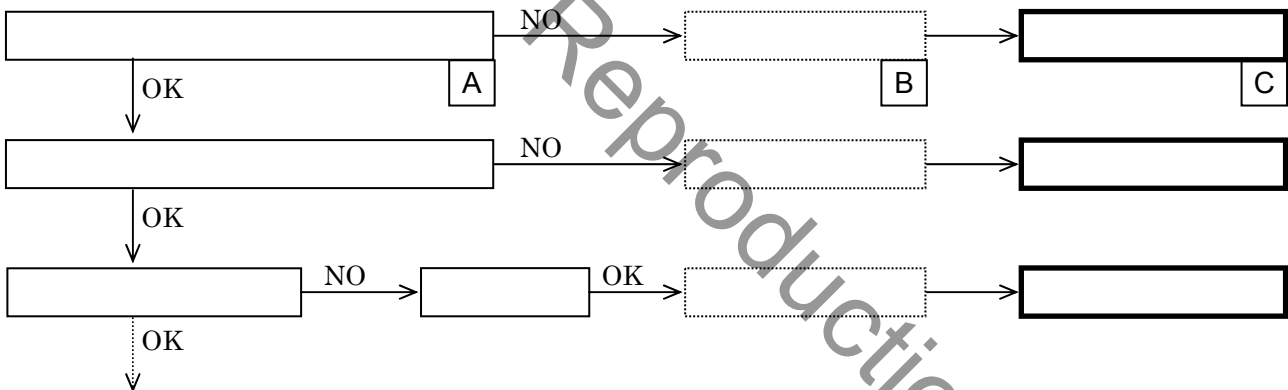

- ① In the troubleshooting column something abnormal is mentioned in lined parenthesis.

- ② In the troubleshooting column the cause of the said trouble is mentioned in dotted parenthesis.

- ③ In the troubleshooting column the countermeasures or treatment are mentioned in the double lined parenthesis.

- ④ under each column means the index of explanation.
For details, see 4.5 “Explanation of Trouble Diagnosis”.

4. Troubleshooting

4.2 Failures of Compressor and Engine

4.2.1 At start-up, starter rotates slowly

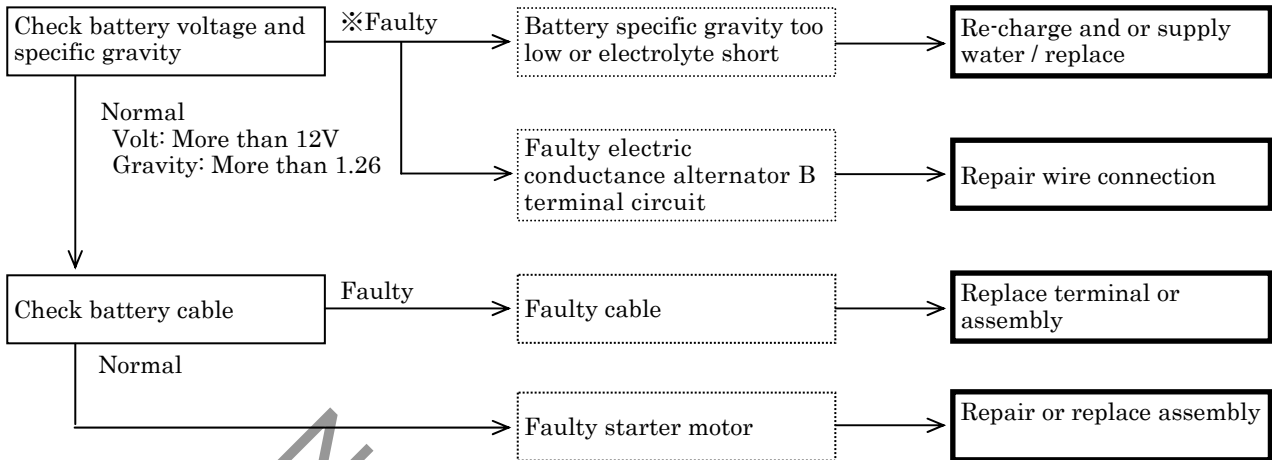

※When starter switch is placed at the “START” position, the battery is not normal if B terminal voltage decreases by 10V.

4.2.2 Starter turns, but engine will not start

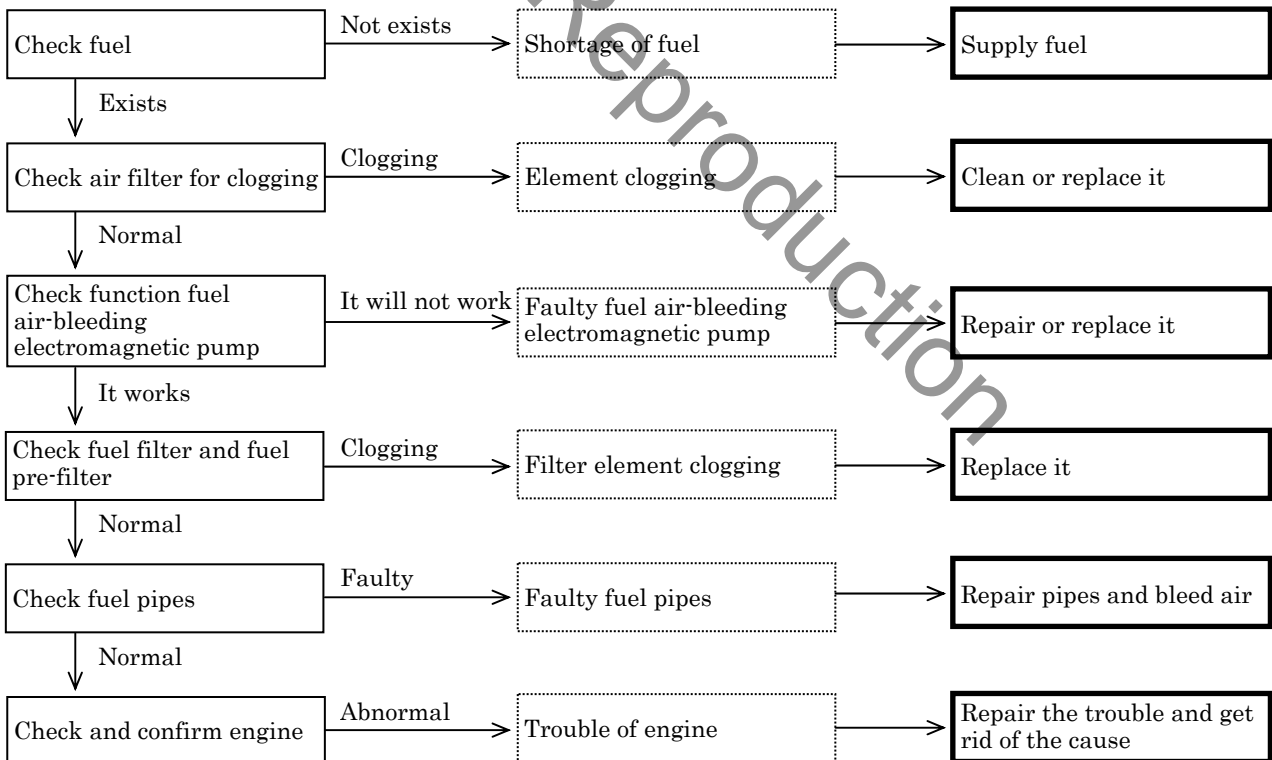

4. Troubleshooting

4.2.3 Engine revolutions will drop before rises up to rated pressure

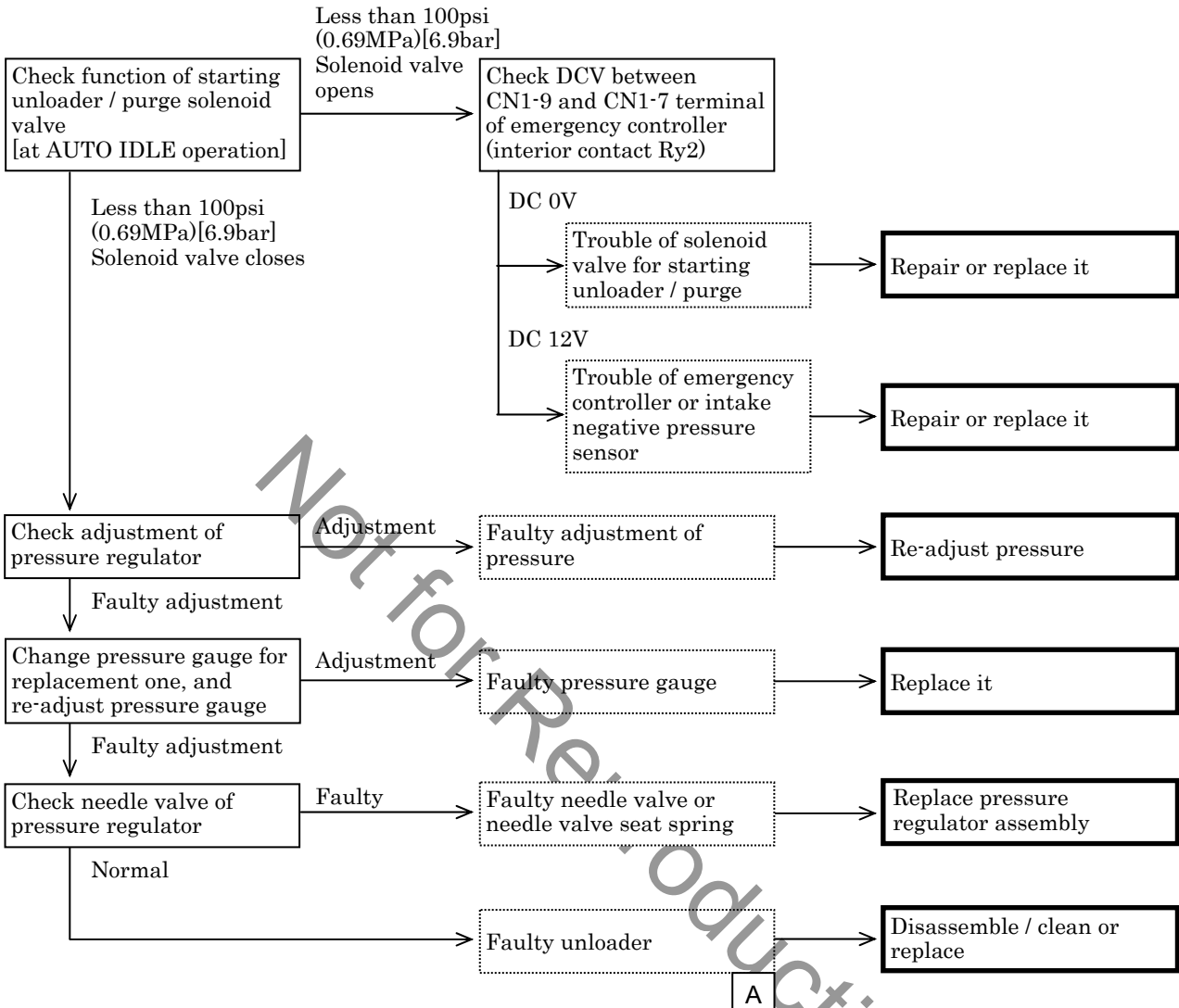

4. Troubleshooting

4.2.4 Engine will not turn to meet rated revolutions

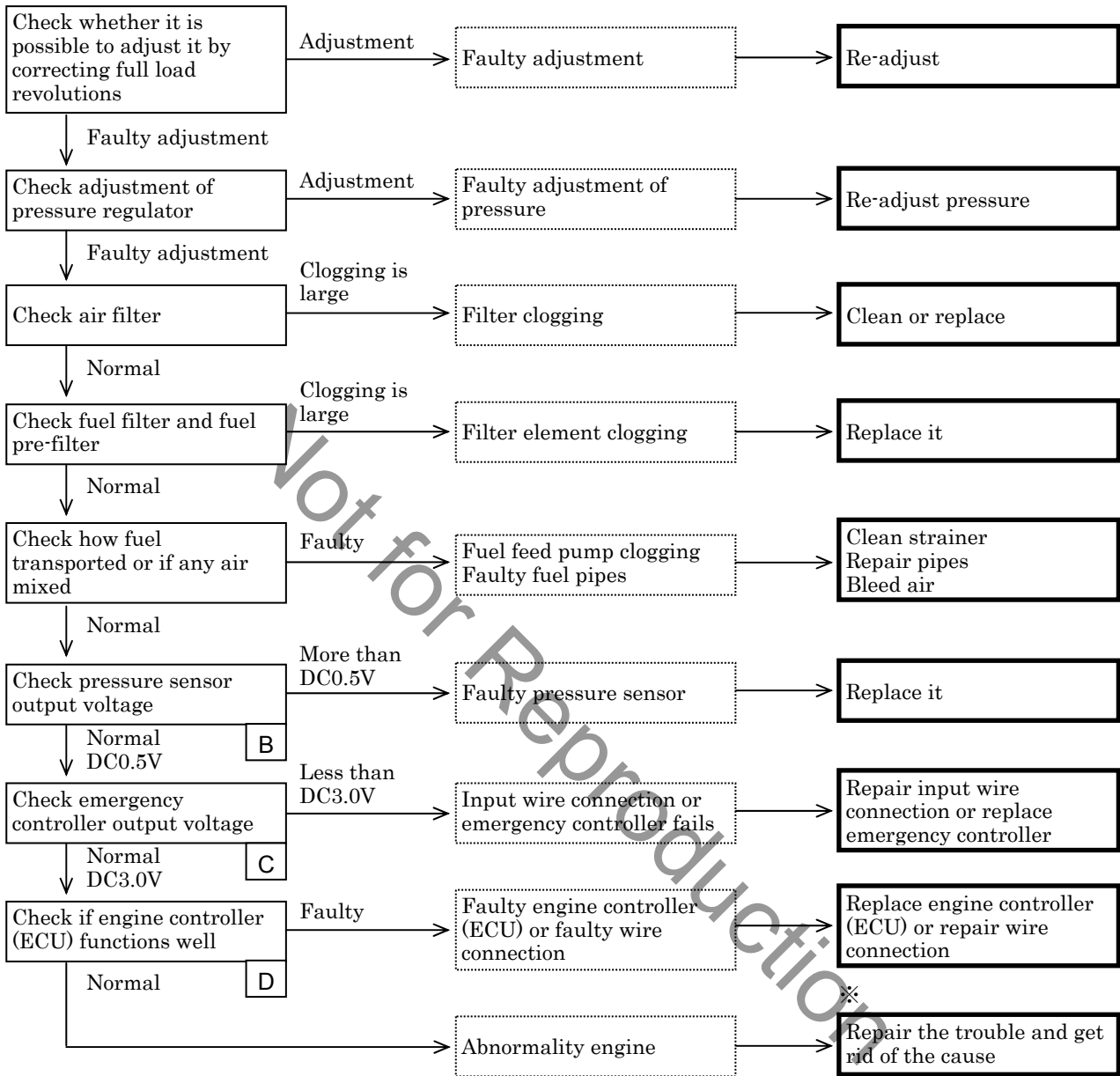

※For the detailed countermeasures, refer to “Service manual” published by engine manufacturer.

4. Troubleshooting

4.2.5 Minimum speed not available even upon no-load operation

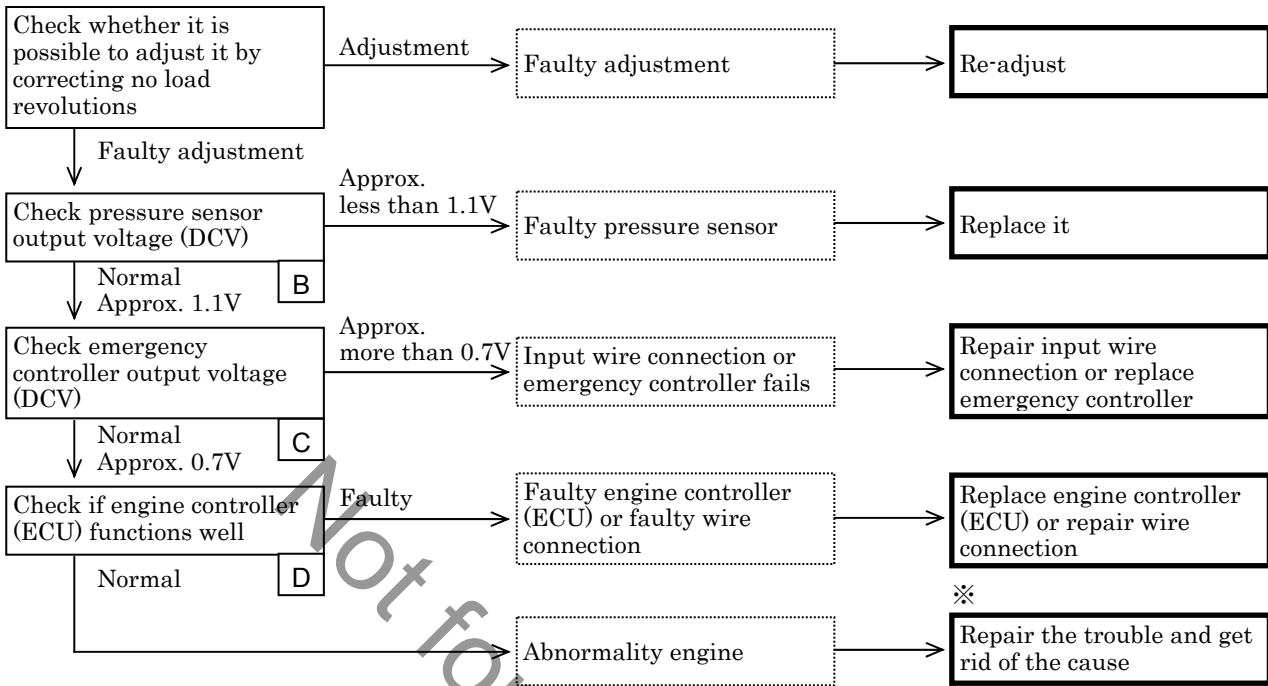

※For the detailed countermeasures, refer to “Service manual” published by engine manufacturer.

4.2.6 Safety valve bursts out during unloaded operation

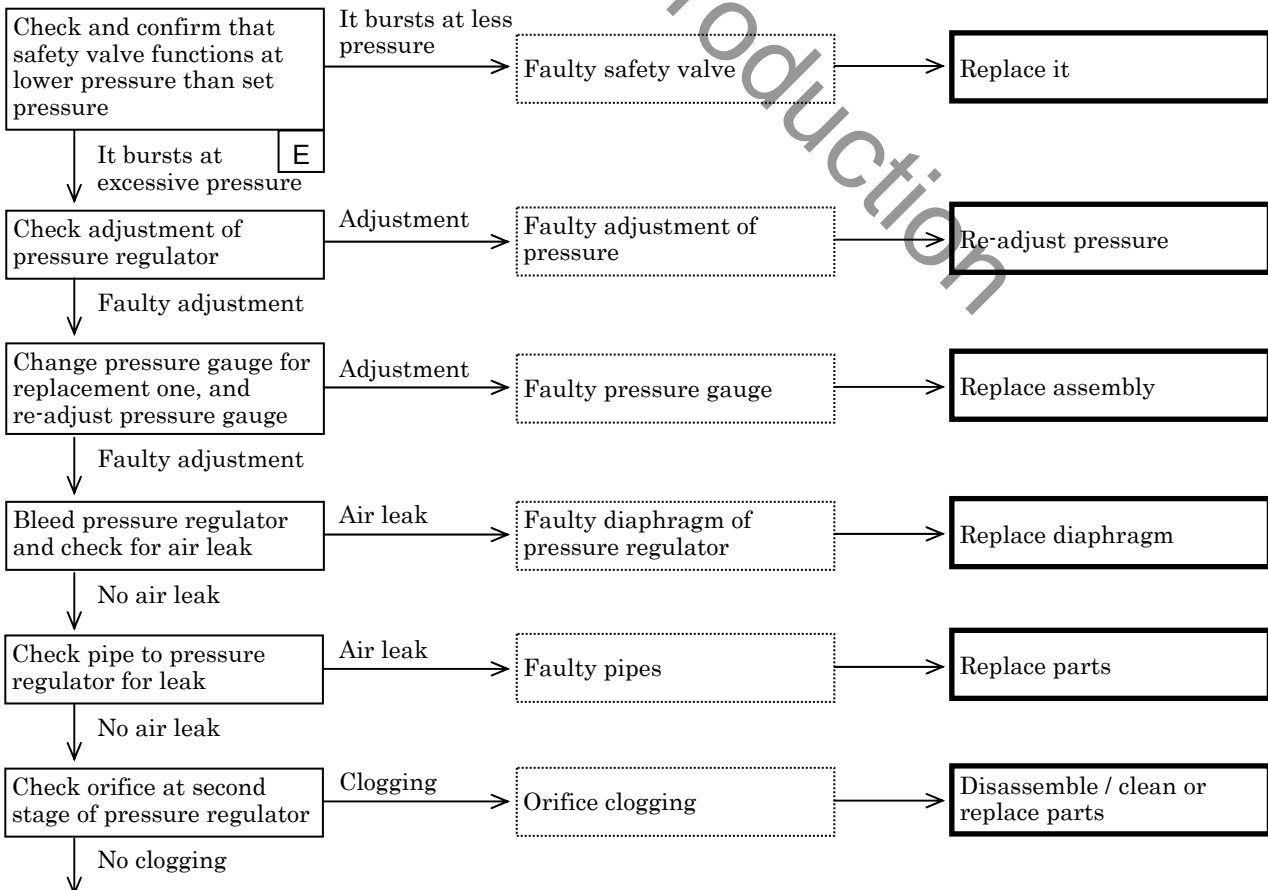

4. Troubleshooting

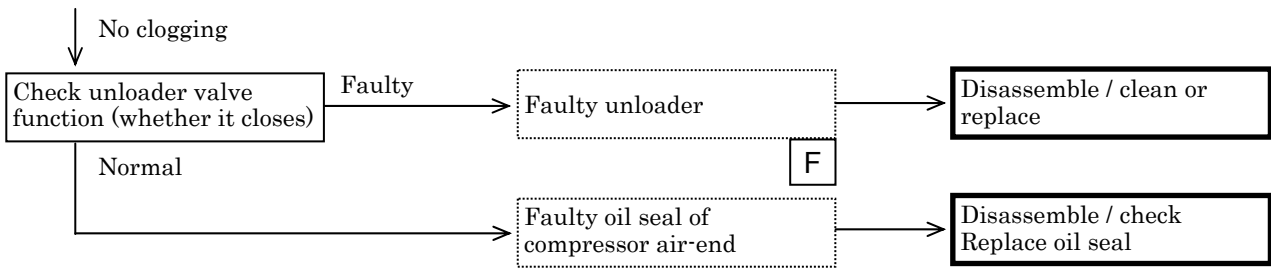

4.2.7 Oil mixed found in delivery air

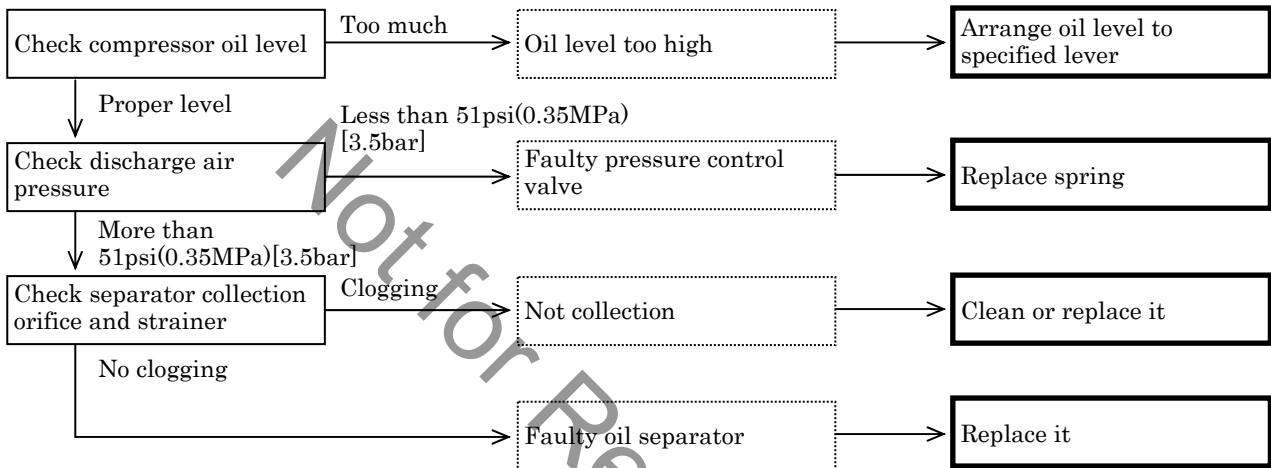

4.2.8 Water found mixed in discharge air (Aftercooler type)

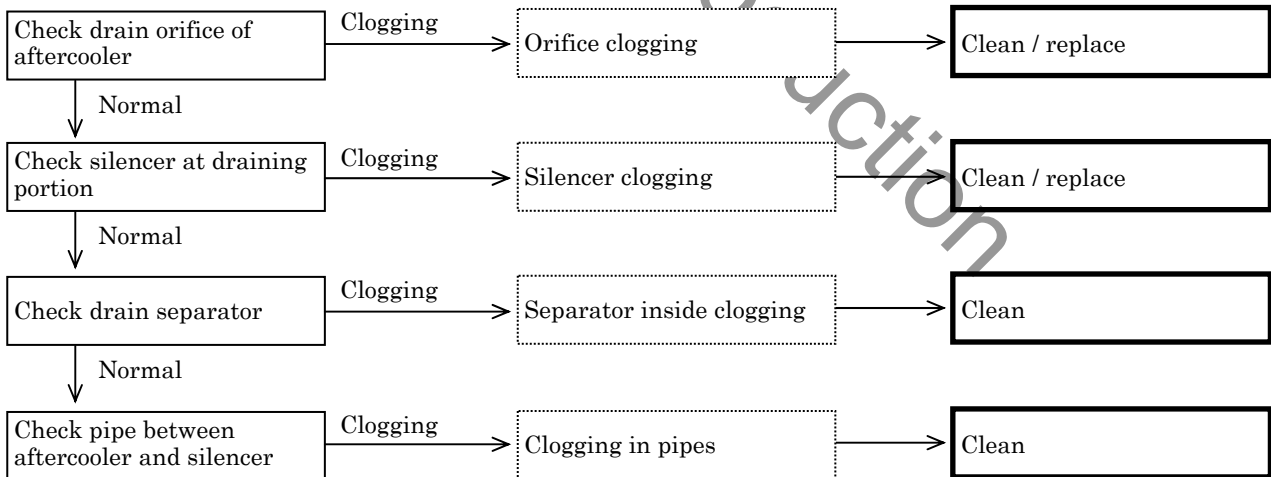

4. Troubleshooting

4.2.9 Discharge air is insufficient

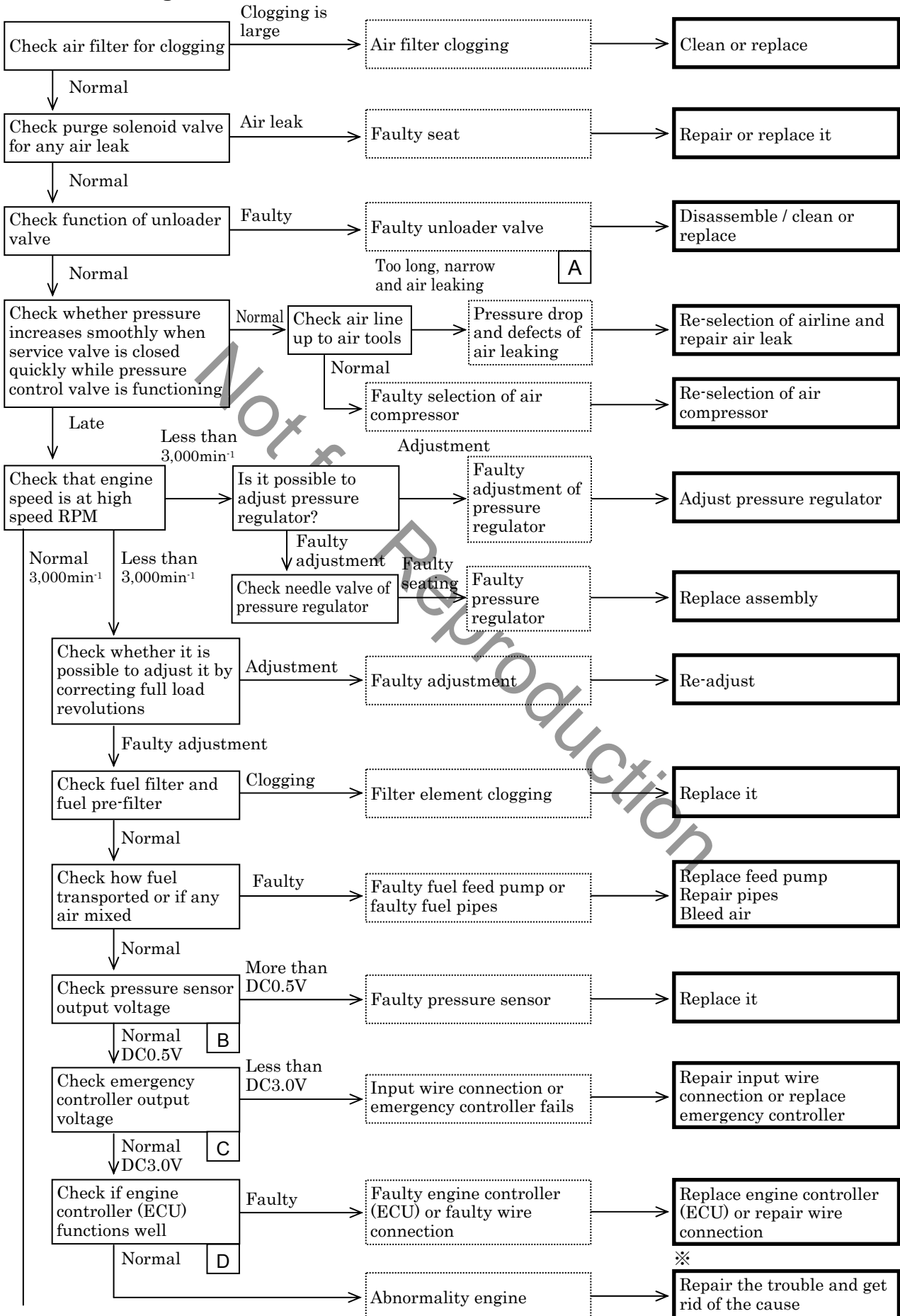

4. Troubleshooting

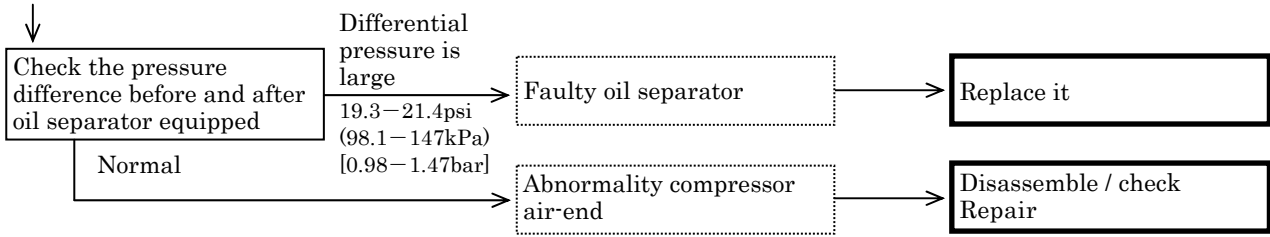

※For the detailed countermeasures, refer to “Service manual” published by engine manufacturer.

4.2.10 Purge control operation will not start even if AUTO IDLE (purge control) switch is pressed

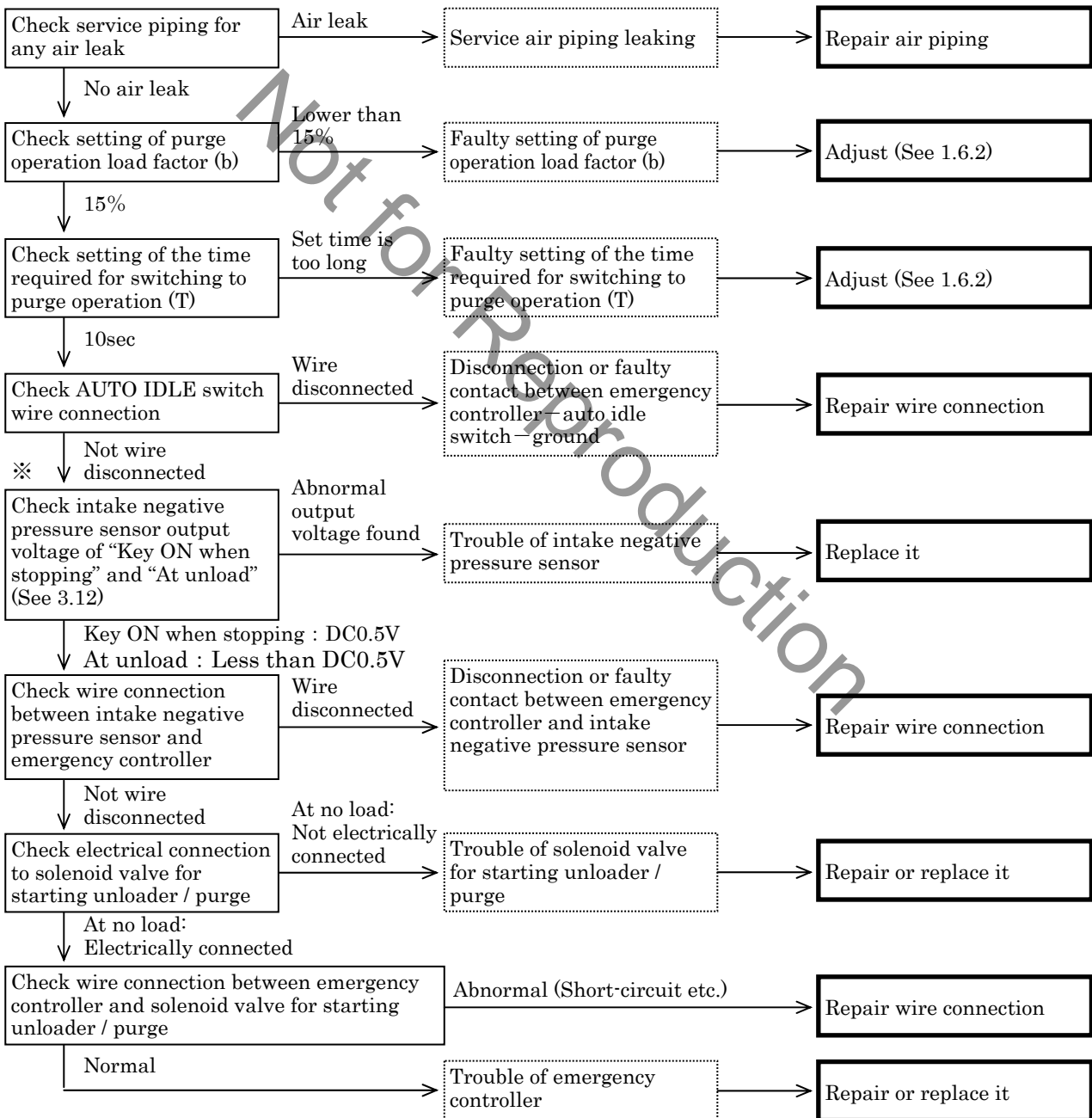

※As the output voltage of intake negative pressure sensor at unload operation is very little, it is better to check the function of purge control operation after replacing the sensor with new one, if it is found difficult to diagnose the trouble.

4. Troubleshooting

4.2.11 Even when the pressure at consumer's side drops, it will not recover from purge control operation

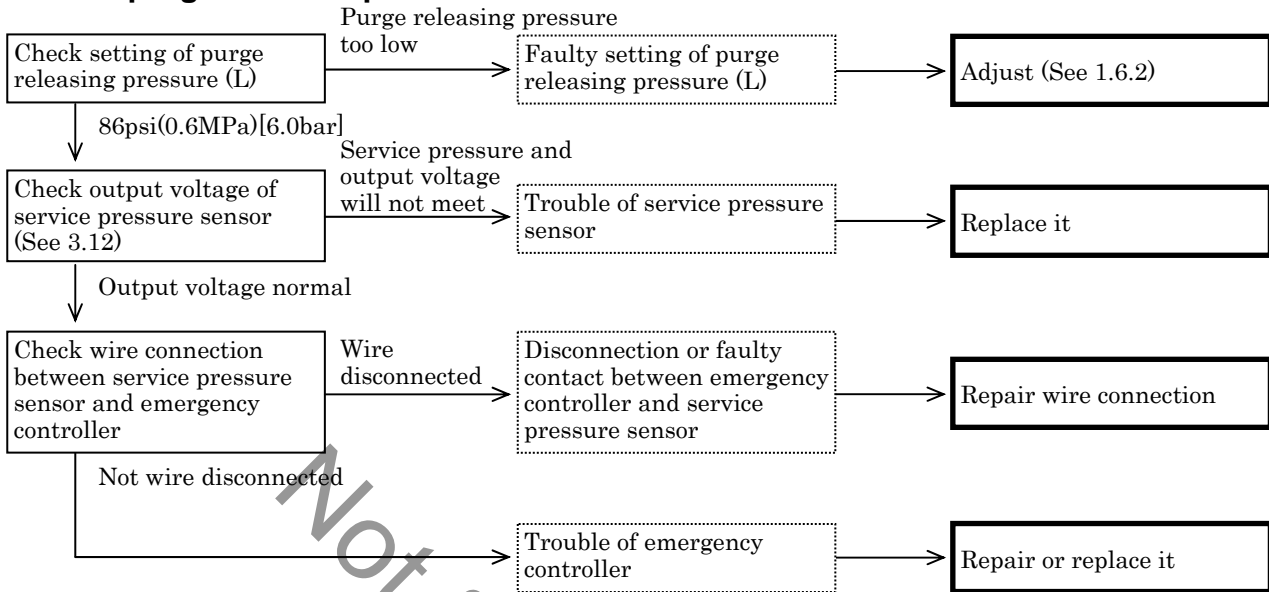

4. Troubleshooting

4.3 Operation of Emergency Switch

4.3.1 Discharge temperature indication lamp glows and engine stops

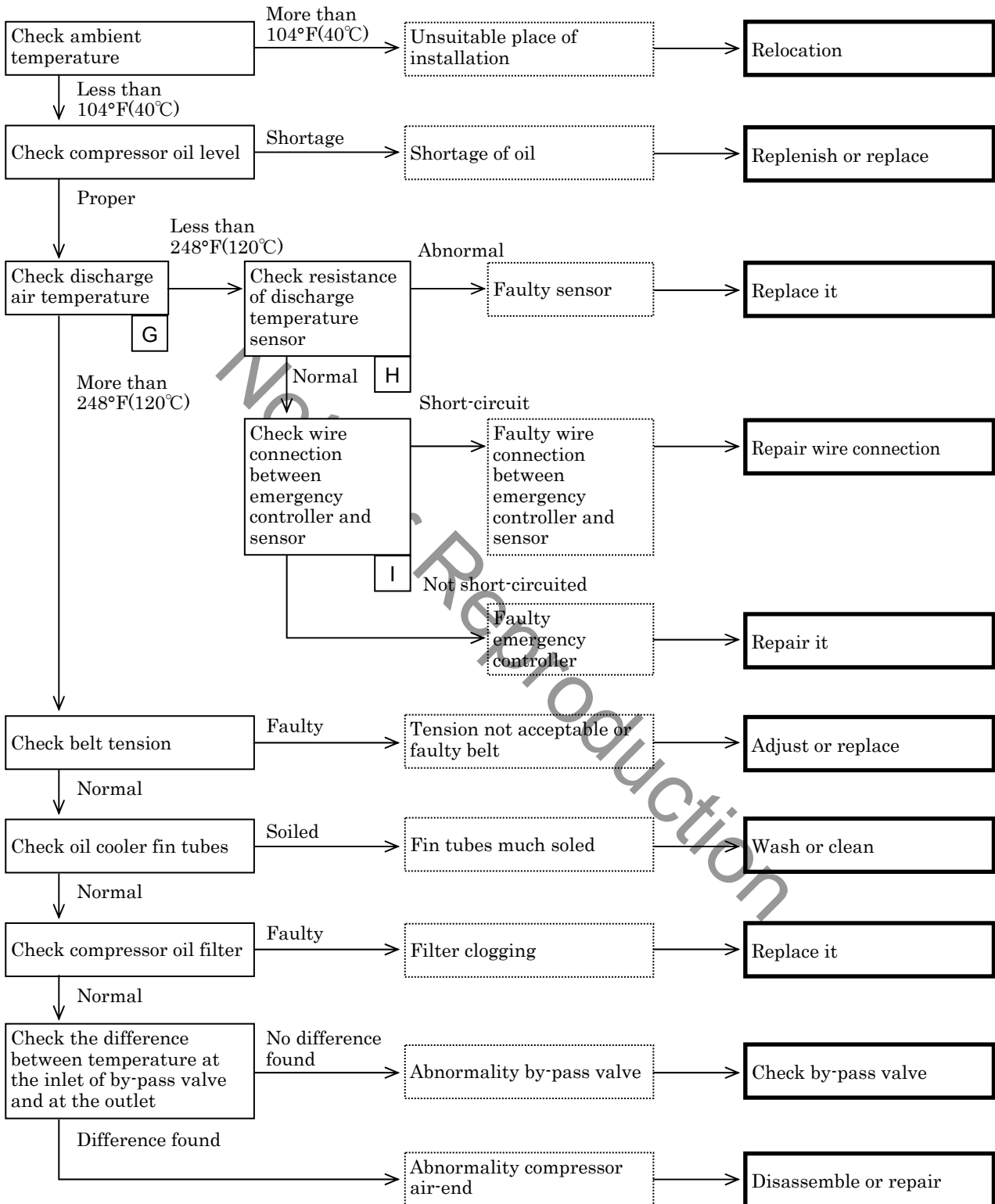

4. Troubleshooting

4.3.2 Engine oil pressure indication lamp glows and engine stops

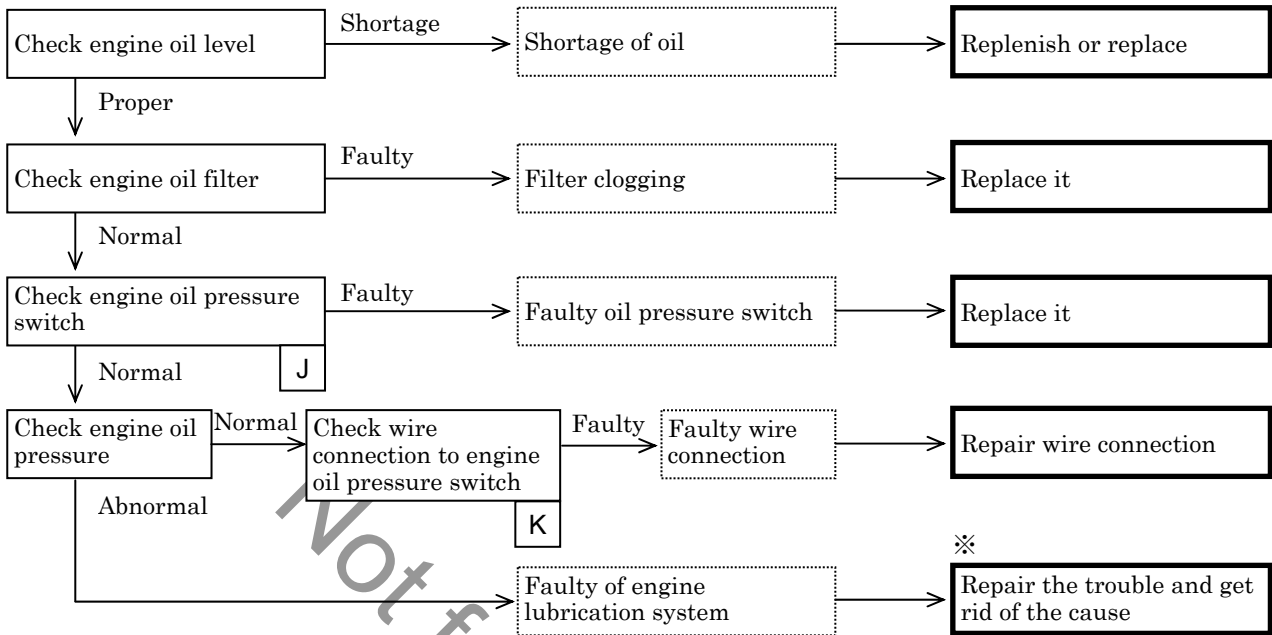

※For the detailed countermeasures, refer to “Service manual” published by engine manufacturer.

4. Troubleshooting

4.3.3 Engine water temperature indication lamp glows and engine stops

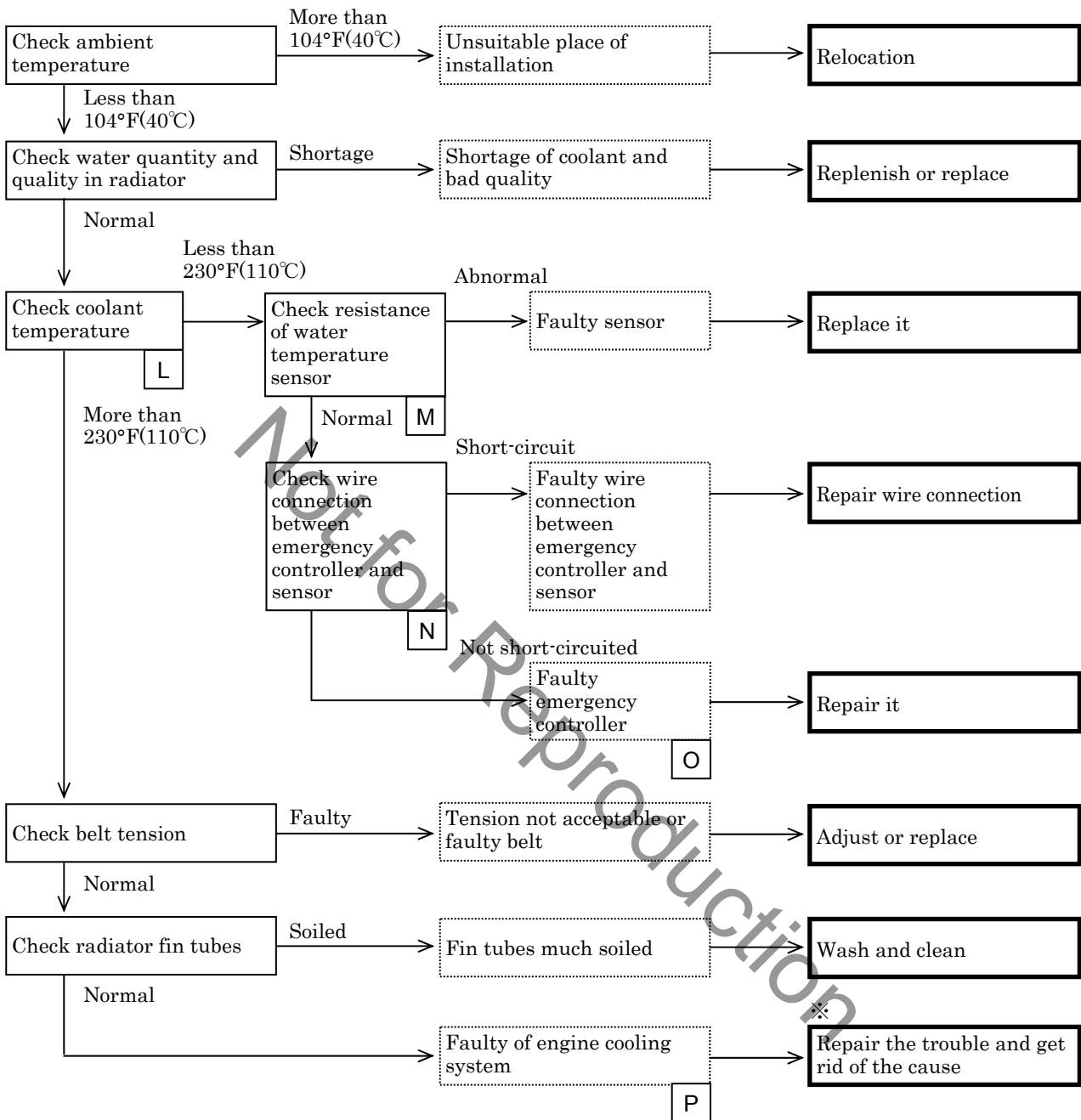

※For the detailed countermeasures, refer to “Service manual” published by engine manufacturer.

4. Troubleshooting

4.4 Others

4.4.1 Residual pressure lamp lights on and engine will not be able to start

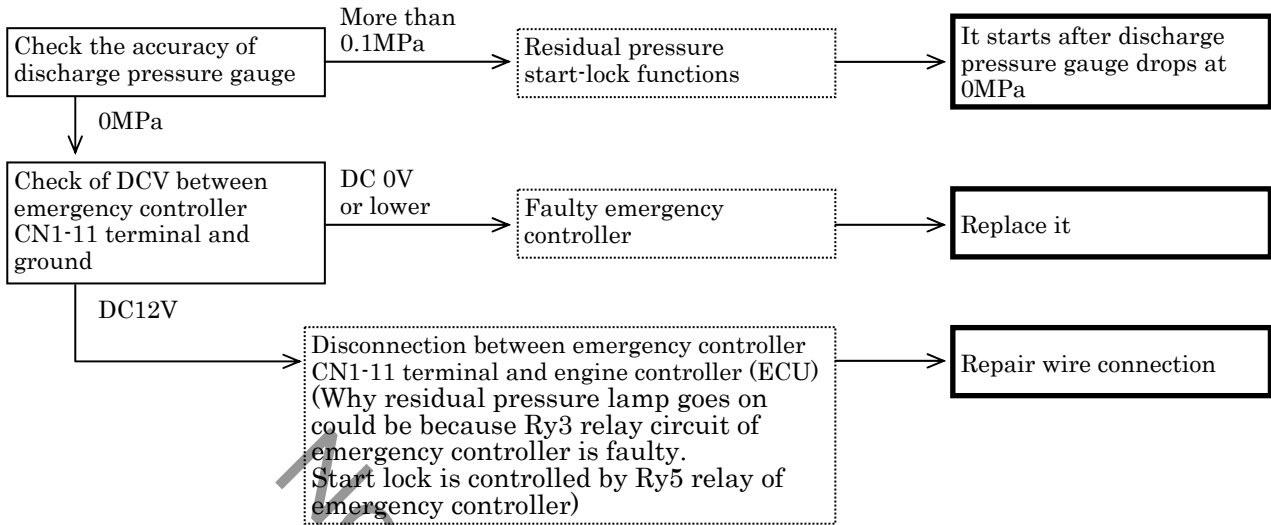

4.4.2 Indicator lamps will not glow, but engine stops

(Starter switch is not set in contact, and blown fuse trouble is exempted.)

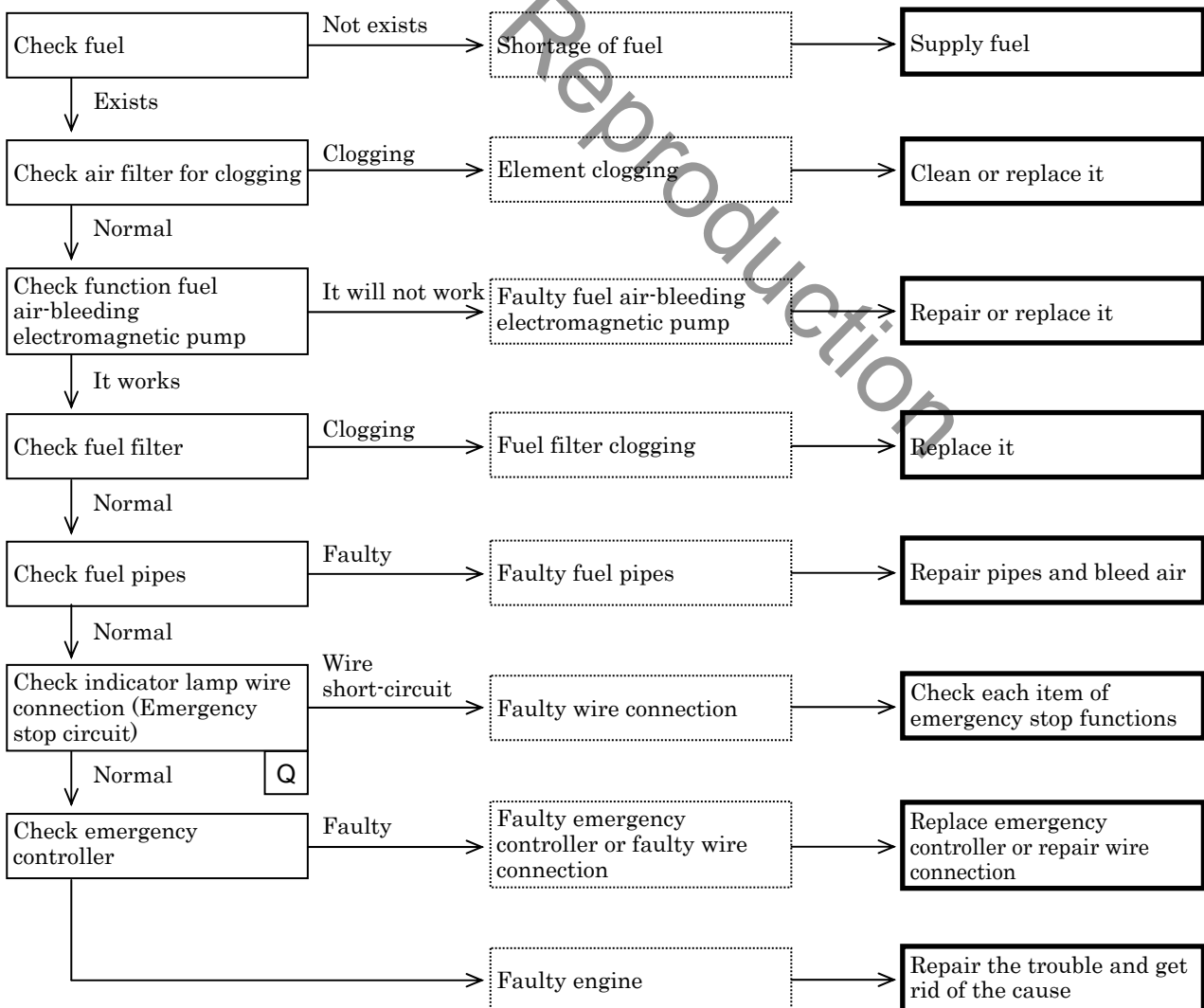

4. Troubleshooting

4.5 Explanation of Trouble Diagnosis

No.	Item	Cause	Remedy
A	Faulty unloader.	Unloader valve cannot be open.	Remove unloader assembly from compressor air-end, and disassemble it for inspection and replace O-ring.
B	Check pressure sensor output voltage.	Engine speed is controlled by the proper speed finally outputted to electro-control fuel injection system in the following flows after pressure sensor detects second stage pressure of regulator. Therefore, when abnormality is found in rotational speed, it is necessary that pressure sensor, emergency controller, engine controller (ECU) and related wires should be checked and confirmed whether they are disconnected and/or short-circuited.	3.2 clause: Emergency Controller 3.12 clause: Check output voltage referring to "Pressure Sensor"
C	Check emergency controller output voltage.		
D	Check if engine controller (ECU) functions well.	<pre> graph TD PS[Pressure sensor] -- Output voltage --> EC[Emergency controller] EC -- Output voltage --> ECU[Engine controller (ECU)] ECU -- "(Control signal)" --> ECFIS[Electronic control fuel injection system] </pre>	Check and confirm in accordance with the "4.6 Engine Trouble Diagnosis Function".
E	Check and confirm that safety valve functions at lower pressure than set pressure.	Check and locate pressure maladjustment or defective safety valve.	In case of malfunction of safety valve, safety valve should be replaced.
F	Faulty unloader.	Faulty seat of unloader valve or faulty function of unloader piston.	Remove unloader assembly from compressor air-end, and disassemble it for inspection and replace O-ring.
G	Check discharge air temperature.	Check whether actual rise of discharge air temperature stops engine or any failure of electrical circuit stops engine.	
H	Check resistance of discharge temperature sensor.	For temperature and resistance characteristics of discharge temperature sensor, see 3.11.	Even disconnection of sensor or its short-circuit causes engine to stop.
I	Check of electric conductance between emergency controller CN2-9 terminal and discharge temperature sensor.	In case that no electrical conductance exists, engine will stop with controller disconnection detecting function 20 seconds after engine starts. In case of short-circuit, engine will be brought to emergency stop.	Repair disconnection and short-circuit.

4. Troubleshooting

No.	Item	Cause	Remedy
J	Check engine oil pressure switch.	When engine oil pressure becomes lower than 7.1psi(0.049MPa)[0.49bar], contact becomes off to bring engine to emergency stop. (Time lag 20 seconds)	Check and confirm in accordance with the “4.6 Engine Trouble Diagnosis Function”.
K	Check for any defective wire connection.	Check and make sure that no disconnection has been found for oil pressure switch.	Repair disconnection.
L	Check coolant temperature by monitor.	Find out whether actually engine stops owing to rise of coolant temperature or owing to defect of electric circuit. Detect coolant temperature in monitor by water temperature sensor.	Check and confirm in accordance with the “4.6 Engine Trouble Diagnosis Function”.
M	Check resistance of water temperature sensor.	For temperature and resistance characteristics of water temperature sensor (Thermistor type), see 3.11.	Even disconnection of sensor or its short-circuit causes engine to stop.
N	Check and confirm that electrical conductance exists between water temperature sensor emergency controller CN2-19 and ground CN2-20 terminal.	In case that no electrical conductance exists, engine will stop with controller disconnection detecting function 20 seconds after engine starts.	Repair disconnection.
O	Check and confirm that DC voltage exists between emergency controller CN1-5 terminal and grounding.	In case that electrical conductance exists between emergency controller CN1-5 terminal and grounding though coolant temperature does not rise abnormally (higher than 110°C), interior contact is closed. So emergency controller could be defective.	Replace emergency controller.
P	Faulty of engine cooling system.	When any trouble is not found in thermostat, coolant pump can be in disorder.	For the temperature at which thermostat valve opens, see 2.13.
Q	Check indicator lamp wire connection.	It sometimes happens that emergency stop circuit is active, but warning lamp will not light on because its circuit is in trouble. Try to locate its cause.	

4. Troubleshooting

4.6 Engine Trouble Diagnosis Function

With regard to this electronic governor engine (Direct injection type with high-pressure common rail system), engine controller (ECU) is equipped with trouble diagnosis function.

4.6.1 Engine trouble diagnosis

1. Check and confirmation of trouble

When engine fails, engine error lamp “1” on monitor panel lights. For the details, take following procedure to check and confirm engine trouble conditions (diagnosis trouble code DTC) by connecting trouble diagnosis tool SMARTASSIST-Direct (hereafter called SA-D).

Permit to use SA-D is required and certified by engine manufacturer. User ID and password are required.

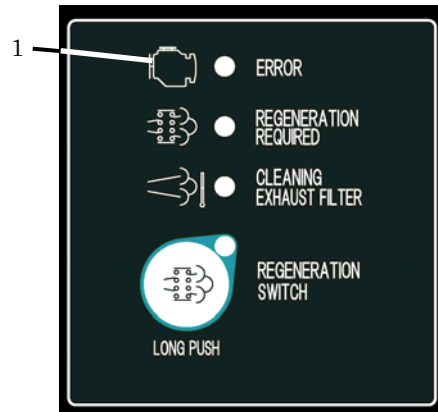

A130992

<Procedure>

- ① The connector (a) (6 poles) for trouble diagnosis tool is to be connected and then starter switch ON.

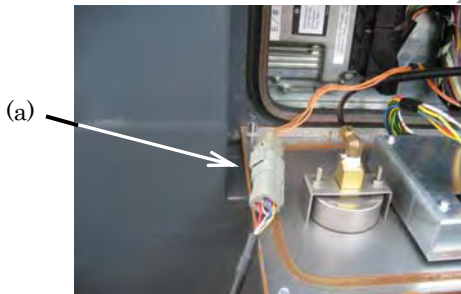

PC14050

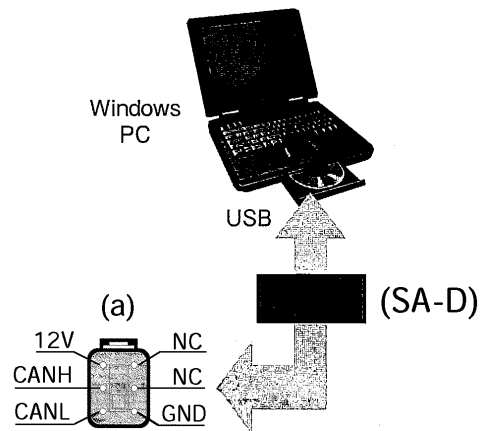

PC13109

- ② Start-up PC to activate SA-D and choose “INDUSTRIAL ENGINE” .

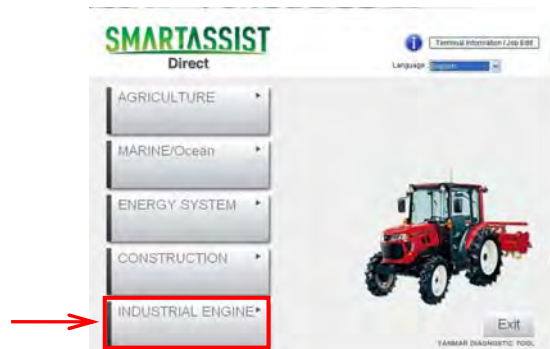

PC14051E

4. Troubleshooting

- ③ Connecting ECU, select “Diagnostics (Execution)” .
and then
communication speed : 250k selection
ECU address 00 : engine selection

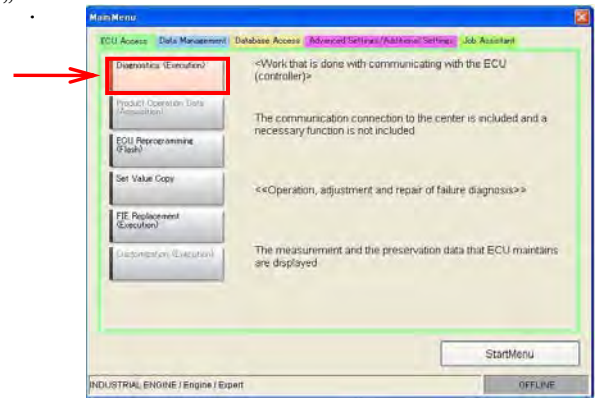

PC14052E

- ④ Select Diagnostic codes – “Logged DTC” from Diagnostics (Execution) screen.

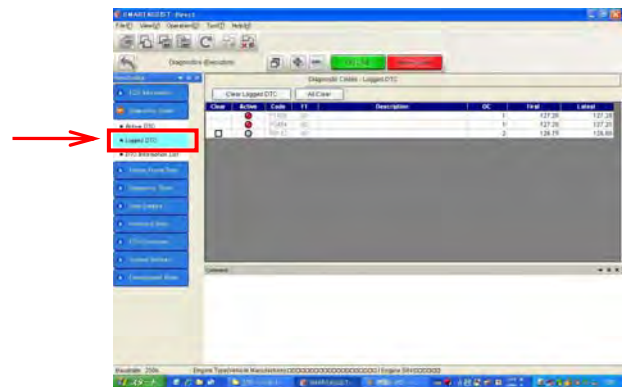

PC14053E

Logged DTC

Clear	Active	Code	FT	Description	OC	First	Latest
<input type="checkbox"/>	<input checked="" type="checkbox"/>	P1465	00		1	127.20	127.20
<input type="checkbox"/>	<input checked="" type="checkbox"/>	P2454	00		1	127.20	127.20
<input type="checkbox"/>	<input type="checkbox"/>	P0122	00		2	126.75	126.80

PC14054E

- ⑤ Clicking “Active failure”, Action and Probable causes will be displayed.

Clear	Active	Code	FT	Description	OC	First	Latest
<input type="checkbox"/>	<input checked="" type="checkbox"/>	P1465	00		1	127.20	127.20
<input type="checkbox"/>	<input checked="" type="checkbox"/>	P2454	00		1	127.20	127.20
<input type="checkbox"/>	<input type="checkbox"/>	P0122	00		2	126.75	126.80

Comment

Action:

Probable cause:

SPN:

- Action
- Probable causes

PC14055E

4. Troubleshooting

⑥ For the list of diagnostic trouble codes, refer to 4.6.2.

For the detailed countermeasures, refer to “Service manual” published by engine manufacturer.

※How to clear Logged DTC after repairing troubles is to be performed by pressing “Clear Logged DTC” or “ALL clear” key.

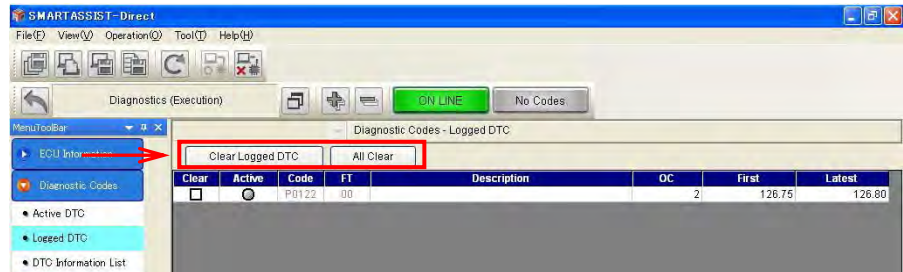

PC14056E

2. DPF Active Regeneration

In DPF regeneration there are automatic regeneration (self-regeneration / assisted regeneration / reset regeneration) and manual regeneration (stationary regeneration). Manual regeneration (stationary regeneration) will be performed by “regeneration switch”, but these forced regenerations can be done optionally. By using SA-D.

※For the details of regeneration, refer to 3.1.4.

<Procedure>

① Select “Active control” from Diagnosis Tests and display “DPF Active Regeneration” screen.

Requirements for active regeneration

- Coolant temperature should be higher than 60°C.
- No failure influencing regeneration should exist.
- At unload speed

When above requirements are fulfilled, push “Set key” after inputting regeneration mode in command value column.

[Regeneration mode command value]

- Assisted regeneration ····· Inputting [1]
- Reset regeneration ······· Inputting [2]
- Manual regeneration ····· Inputting [3] (Stationary regeneration)

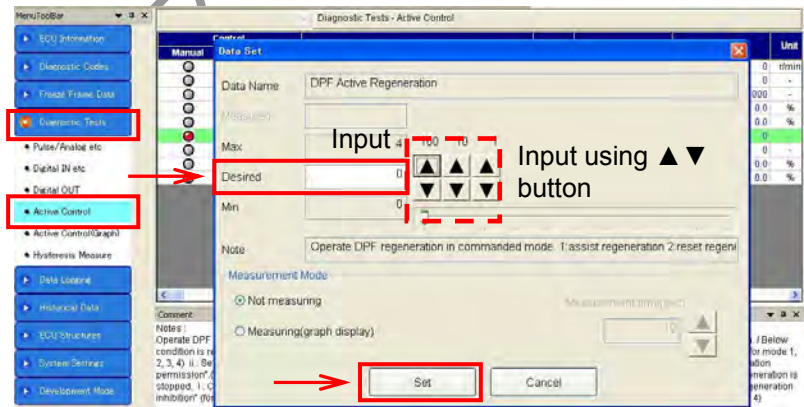

PC14057E

4. Troubleshooting

② Implementing DPF Active Regeneration.

Press RUN button to proceed regeneration. Stopping it, press STOP button.

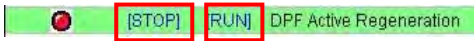

When regeneration is finished, Red lamp goes off.

The screenshot shows the 'Diagnosis - Active Control' window. A table lists various control parameters. The row for 'DPF Active Regeneration' is highlighted in green. The table has columns for Manual, Control, Description, ENG Run, Measured, Desired, and Unit.

Manual	Control	Description	ENG Run	Measured	Desired	Unit
[STOP]	[RUN]	Direct Engine RPM Control	req	1352	0	rpm
[STOP]	[RUN]	Direct EGR Valve Control	not		0	-
[STOP]	[RUN]	Injector Test	-		0000	-
[STOP]	[RUN]	Intake Throttle Position Control	not		0.0	%
[STOP]	[RUN]	Exhaust Throttle Position Control	not		0.0	%
[STOP]	[RUN]	DPF Active Regeneration	req	3	-	-
[STOP]	[RUN]	Direct EGR Valve Control (for Development)	-		0	-
[STOP]	[RUN]	Intake Throttle Position Control (for Development)	-		0.0	%
[STOP]	[RUN]	Exhaust Throttle Position Control (for Development)	-		0.0	%

Notes:
 Operate DPF regeneration in commanded mode. 1: assist regeneration 2: reset regeneration 3: stationary regeneration 4: recovery regeneration / Below condition is required for each regeneration mode. i: Coolant temperature is greater than 60 degree or passed 15 minutes after engine start (for mode 1, 2, 3, 4) ii: Set DPF regeneration inhibition SW to "Regeneration permission" (for mode 2, 3, 4) iii: Set regeneration interlock SW to "Regeneration permission" (for mode 3, 4) iv: Set low idle engine speed (for mode 3, 4) / Regeneration is automatically finished in the below condition regeneration is stopped. i: Click stop button on the screen (for mode 1, 2, 3, 4) ii: Key off (for mode 1, 2, 3, 4) iii: Set DPF regeneration inhibition SW to "Regeneration inhibition" (for mode 2, 3, 4) iv: Set regeneration interlock SW to "Regeneration inhibition" (for mode 3, 4) v: Operate acceleration (for mode 3, 4)

PC14058E

Not for Reproduction

4. Troubleshooting

4.6.2 List of diagnostic trouble codes (DTC)

This clause shows the list of the diagnostic trouble codes when engine is in trouble, which are explained in 4.6.1.

DTC code	Description	DTC code	Description
P0008	No signal from both sensors	P0471	EGR high-pressure side sensor abnormal learning value
P000F	PLV valve is open	P0472	EGR high-pressure side sensor (insufficient sensor output)
P0088	Abnormally high rail pressure	P0473	EGR high-pressure side sensor (excessive sensor output)
P0093	Rail pressure deviation fault (rail pressure is too high)	P0488	EGR position sensor fault
P0094	Rail pressure deviation fault (rail pressure is too low)	P049D	EGR initialization fault
P0112	Fresh air temperature sensor (insufficient sensor output)	P0541	Startup assist relay GND short-circuit
P0113	Fresh air temperature sensor (excessive sensor output)	P0543	Startup assist relay disconnection
P0117	Water temperature sensor (insufficient sensor output)	P0545	Exhaust manifold temperature sensor (insufficient sensor output)
P0118	Water temperature sensor (excessive sensor output)	P0546	Exhaust manifold temperature sensor (excessive sensor output)
P0122	Accelerator sensor 1 (insufficient sensor output) ※1	P0601	EEPROM memory deletion fault
P0123	Accelerator sensor 1 (excessive sensor output) ※1	P0611	Injector drive circuit IC error
P0168	Increase in fuel temperature	P0627	High-pressure pump drive circuit disconnection
P0182	Fuel temperature sensor (insufficient sensor output)	P0629	High-pressure pump drive circuit high side VB short-circuit
P0183	Fuel temperature sensor (excessive sensor output)	P062A	High-pressure pump drive circuit current (high level)
P0192	Rail pressure sensor (insufficient sensor output)	P0660	No load on the drive H bridge circuit of throttle valve
P0193	Rail pressure sensor (excessive sensor output)	P068A	Early opening of the main relay
P0201	Disconnection (in a particular location of injector 3)	P068B	Main relay fixation
P0202	Disconnection (in a particular location of injector 2)	P1101	Air cleaner blockage alarm ※2
P0203	Disconnection (in a particular location of injector 4)	P1146	Injector bank 1 short-circuit
P0204	Disconnection (in a particular location of injector 1)	P1149	Injector bank 2 short-circuit
P0217	Increase in coolant temperature	P1151	Oil and water separator alarm
P0219	Speed excess	P1192	Hydraulic pressure SW disconnection
P0236	EGR low-pressure side sensor abnormal learning value	P1198	Low hydraulic pressure alarm
P0237	EGR low-pressure side sensor (insufficient sensor output)	P1227	Sensor failure (pulse communication)
P0238	EGR low-pressure side sensor (excessive sensor output)	P1231	Abnormal atmospheric pressure sensor characteristic
P0262	Injector 3 coil short	P1262	Injector 3 short circuit
P0265	Injector 2 coil short	P1265	Injector 2 short circuit
P0268	Injector 4 coil short	P1268	Injector 4 short circuit
P0271	Injector 1 coil short	P1271	Injector 1 short circuit
P02E8	Intake throttle opening sensor (insufficient sensor output)	P1341	Angular offset abnormal
P02E9	Intake throttle opening sensor (excessive sensor output)	P1404	EGR low-voltage fault
P0336	Crank abnormal signal	P1405	Short circuit between EGR motor coils
P0337	Crank No signal	P1409	EGR feedback fault
P0341	Cam abnormal signal	P1410	High-temperature EGR thermistor fault
P0342	Cam No signal	P1411	Low-temperature EGR thermistor fault
P0403	Disconnection between EGR motor coils	P1420	DPF Ash cleaning request 2
P0404	EGR over-voltage fault	P1421	DPF Stationary regeneration standby
P040C	EGR gas post-confluence temperature sensor (insufficient sensor output)	P1424	DPF Backup mode
P040D	EGR gas post-confluence temperature sensor (excessive sensor output)	P1426	DPF intermediate temperature sensor abnormally high temperature (post injection defect)
P041C	EGR gas temperature sensor (insufficient sensor output)	P1427	DPF entrance temperature sensor (insufficient sensor output)
P041D	EGR gas temperature sensor (excessive sensor output)	P1428	DPF entrance temperature sensor (excessive sensor output)
P0420	Abnormally low DPF temperature (middle temperature)	P1434	DPF middle temperature sensor (excessive sensor output)

※1 Accelerator sensor 1 will be rearranged into pressure sensor circuit.

※2 Warning items for Air cleaner blockage alarm and oil/water separator alarm are not included.

4. Troubleshooting

DTC code	Description
P1435	DPF middle temperature sensor (insufficient sensor output)
P1436	DPF inlet temperature sensor abnormally high temperature
P1445	DPF recovery regeneration failure
P1446	DPF recovery regeneration prohibition
P1454	DPF high pressure side sensor (insufficient sensor output)
P1455	DPF high-pressure side sensor (excessive sensor output)
P1463	Over PM accumulation (P method) The operation transits to backup mode when the following condition continues for 300 seconds PM accumulation amount (P method) is greater than or equal to 12(g/L)
P1467	Actuator drive circuit 3 short to ground
P1469	ECU AD converter fault 1
P1470	ECU AD converter fault 2
P1471	ECU external monitoring IC and CPU fault 1
P1472	ECU external monitoring IC and CPU fault 2
P1473	ECU ROM fault
P1474	ECU shutoff path fault 1
P1475	ECU shutoff path fault 2
P1476	ECU shutoff path fault 3
P1477	ECU shutoff path fault 4
P1478	ECU shutoff path fault 5
P1479	ECU shutoff path fault 6
P1480	ECU shutoff path fault 7
P1481	ECU shutoff path fault 8
P1482	ECU shutoff path fault 9
P1483	ECU shutoff path fault 10
P1484	Recognition error of engine speed
P148A	EGR valve stuck open fault
P1562	Charge SW disconnection
P1568	Charge alarm
P1608	Excessive voltage of ECU supply 1
P1609	ECU sensor supply voltage error 1
P160E	EEPROM memory reading fault
P160F	EEPROM memory writing fault
P1613	ECU CY146 SPI communication fault
P1617	Insufficient voltage of ECU supply 1
P1618	ECU sensor supply voltage error 2
P1619	ECU sensor supply voltage error 3
P1626	ECU actuator drive circuit 1 short to ground
P1633	ECU actuator drive circuit 2 short to ground
P1641	High-pressure pump drive circuit low side VB short-circuit
P1642	High-pressure pump drive circuit high side GND short-circuit
P1643	High-pressure pump drive circuit low side GND short-circuit
P1645	High-pressure pump overload error
P1646	Dual accelerator sensor (closed position) failure

DTC code	Description
P1647	Dual accelerator sensor (open position) failure
P1648	QA corrected injection amount for cylinder NO.1 error
P1649	QA corrected injection amount for cylinder NO.2 error
P1650	QA corrected injection amount for cylinder NO.3 error
P1651	QA corrected injection amount for cylinder NO.4 error
P1658	VB short-circuit of the drive H bridge output 1 of throttle valve
P1659	GND short-circuit of the drive H bridge output 1 of throttle valve
P1660	Overload on the drive H bridge circuit of throttle valve
P1661	VB short-circuit of the drive H bridge output 2 of throttle valve
P1662	GND short-circuit of the drive H bridge output 2 of throttle valve
P1665	Controlled rail pressure error after PLV valve opening
P1666	The times of PLV valve opening error
P1667	The time of PLV valve opening error
P1668	The actual rail pressure is too high during PLV limp home
P1669	Injector B/F temperature error during PLV limp home
P1670	Operation time error during RPS limp home
P2228	Atmospheric pressure sensor (insufficient sensor output)
P2229	Atmospheric pressure sensor (excessive sensor output)
P242F	DPF Ash cleaning request 1
P2452	DPF differential pressure sensor abnormally high pressure
P2453	DPF differential pressure sensor abnormal learning value
P2454	DPF differential pressure sensor (insufficient sensor output)
P2455	DPF differential pressure sensor (excessive sensor output)
P2458	Regeneration defect (stationary regeneration failed) Stationary regeneration is not completed within the specified time
P2459	Regeneration defect (stationary regeneration not operated)
P2463	Over PM accumulation (C method) The operation transits to backup mode when the following condition continues for 300 seconds PM accumulation amount (C method) is greater than or equal to 12(g/L)
U010B	CAN message from the EGR valve time out
U0167	Immobilizer CAN communication error
U0168	VI reception time out error
U0292	TSC1 reception time out (SA1)
U0401	EGR ECM data fault
U0426	Immobilizer system error
U1292	Y_ECR1 reception time out error
U1293	Y_EC reception time out error
U1294	Y_RSS reception time out error
U1300	V-ETCP1 reception time out
U1301	TSC1 reception time out (SA2)
U1302	EBC1 reception time out error
U1303	Y_DPFIF reception time out error
U1401	Out of EGR target value range
U3002	VI reception data fault

4. Troubleshooting

4.6.3 Trouble diagnosis tool (SMARTASSIST-Direct)

Using SMARTASSIST-Direct (hereafter called SA-D), it is possible to diagnose electrical failure of engine control system and check the system, by reading diagnostic troubles codes (DTC) and referring to troubleshooting manual and renewal/replacement of parts change information, injection enforced driving and checking and confirming engine various control values.

Permit to use SA-D is required and certified by engine manufacturer. User ID and password are required.

1. SA-D of the function CAN : Controller area network

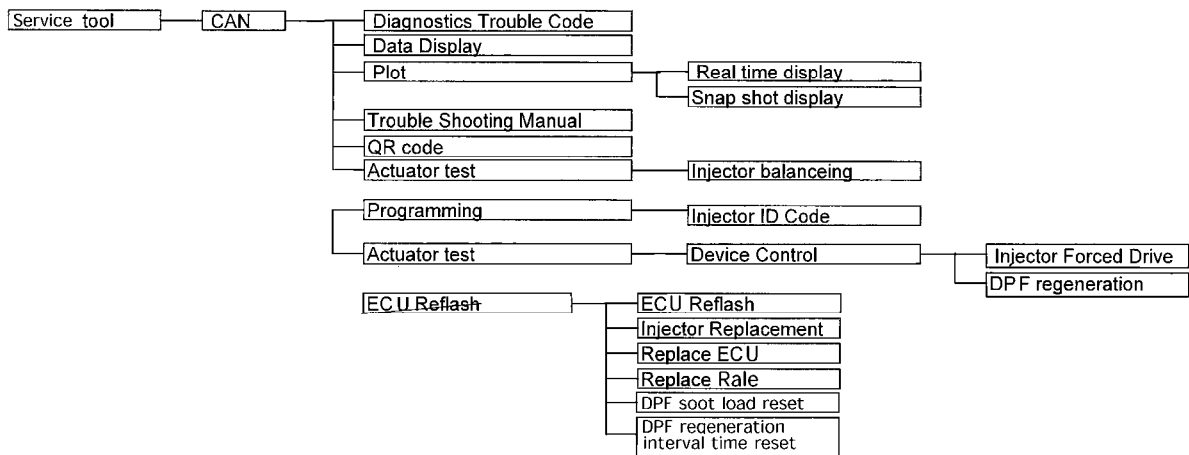

PC13111

2. Appearance

1. SA-D
2. USB cable
3. Data link cable

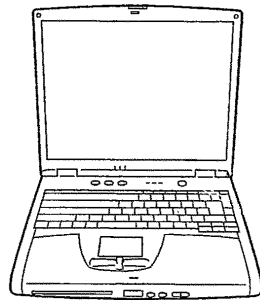

SG13105



PC14060

※Connector (6 poles) for machine side trouble diagnosis tool is provided at left corner inside monitor panel. Refer to 4.6.1.

3. Injector IR / DMC (QR code)

1. IR code (Correction value)
2. DMC (QR code)
3. Part number

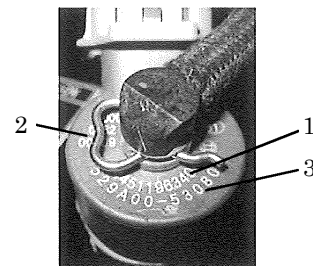

PC13112

4. Troubleshooting

4. Renewal/replacement of parts change information

- ① When replacing ECU, software download/rewriting should be done.

[Supplementary ECU does not contain software and data. And so it is necessary to download the data and ECU log which is not yet changed (injection correction value and etc.,) should be necessarily re-written and also it is necessary to change Ser. No. of ECU.]

- ② When replacing injectors, correction value should be re-written in ECU.
③ When replacing the rail, ECU should be reset.
④ When replacing DPF (Diesel particulate filter), parts numbers of SF (Soot filter) and DOC (Diesel oxidation catalyst) and Ser. No. should be inputted. Further new parts/cleaning parts should be selected and accumulated sedimentary data should be reset.

※For the details, contact your nearest dealer.

Not for Reproduction

5. References

5.1 Consumable Parts and Electrical Appliances

Item	Part Number
●Element / Filter / Belt	
Air filter ASS'Y (For compressor)	32100 44900
Air filter element (outer)	32143 11800
Air filter ASS'Y (For engine)	32100 44601
Air filter element (outer)	32143 11700
Oil separator	34220 16101
O-ring for oil separator	03402 15145
Compressor oil filter cartridge	37438 08900
Engine oil filter cartridge	41290 01200 (YANMAR:129150-35153)
Fuel filter cartridge	43543 02100 (YANMAR:129A00-55800)
Fuel pre-filter ASS'Y	43540 08800 (YANMAR:529A00-55730)
Element	(YANMAR:129A00-55730)
O-ring (element side)	(YANMAR:129A00-55740)
O-ring (drain cap)	(YANMAR:129242-55740)
Belt	(YANMAR:129612-42350)
●Air control	
Pressure regulator	36400 19000
Auto-relief valve / Vacuum relief valve	(built-in unloader)
O-ring	03402 25008
O-ring	03402 25021
O-ring	21221 02100
Unloader valve	22100 41202
O-ring (2 pieces)	03402 10125
O-ring	03402 10070
O-ring	21441 04800
O-ring	21441 04900
Pressure control valve	35300 17000
O-ring	03402 15075
O-ring	03402 25032
Spring	22144 07700
Piston	35303 03300
●Oil line	
By-pass valve ASS'Y	37200 11502
Pellet	37231 02100
O-ring	03402 25045
O-ring	03402 15025
O-ring	03402 15045

5. References

Item	Part Number
●Electrical appliances	
Emergency controller	46870 64001
Engine controller(ECU)	46870 64400
Starter/glow plug relay	44346 16600 (YANMAR:129927-77920)
EGR valve relay	44346 16500 (YANMAR:198461-52950)
Starting unloader (for purge) solenoid valve	46811 30000
Fuse 10A	46934 03200
Fuse 20A (2 pieces)	46934 03300
Fuse 50A	44470 02900
Fuse 80A	44470 03000
Intake negative pressure sensor	44328 20600
Service pressure sensor	44328 20600
Regulator secondary pressure sensor	44328 20600
Discharge temperature sensor	44364 06500
Water temperature sensor	44364 06500
Engine oil pressure switch	(YANMAR:119761-39450)
Sending unit	36159 04100
Fuel air-bleeding electromagnetic pump	43650 02700 (YANMAR:129612-52100)
Residual pressure start prohibition lamp	46161 14500
Air filter differential pressure indicator	32148 03000
DPF unit	(YANMAR:119C20-17040)
●Instruments on panel	
Starter switch	44322 07300 (YANMAR:129115-91250)
Pressure gauge	36141 18600

5.2 Engine Wiring Diagram

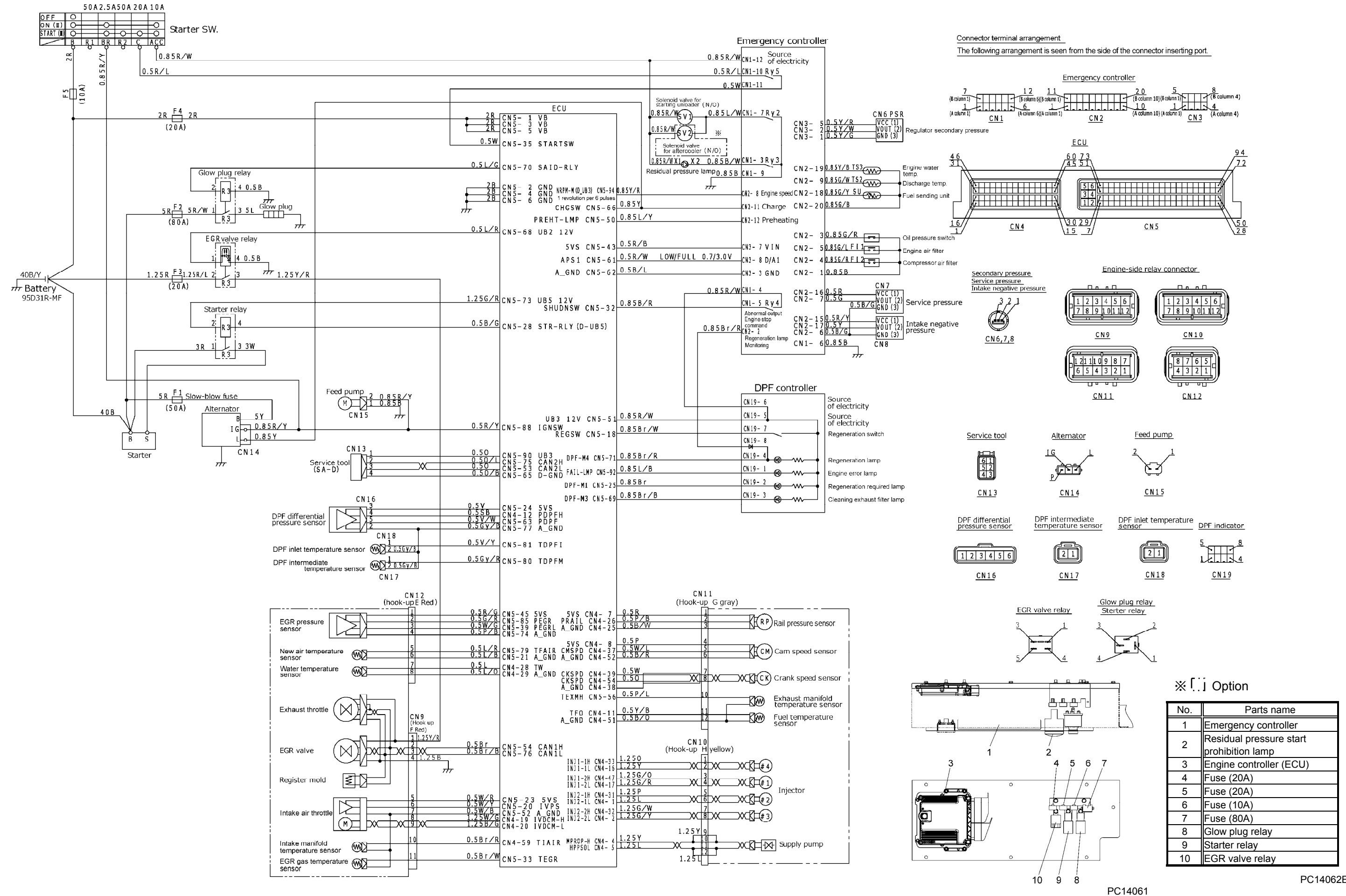

Not for Reproduction

Not for Reproduction