

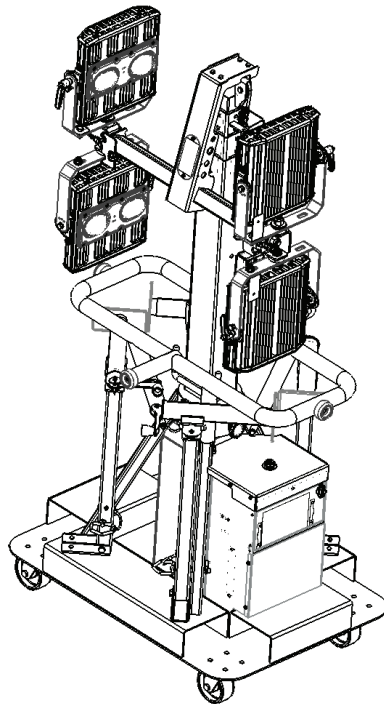

(en) **Operator's Manual**
Night-Lite™ E-Series
Portable Light Tower



Copyright © 2018 Allmand Bros., Inc.
Holdrege, NE, USA. All rights reserved.

Part No.: 112170USCN
Revision: B

Record Important Information

Recording the equipment information will help when placing an order for replacement parts and/or decals.

Unit Model No: _____

Unit Serial No: _____

Manual Contents:

Introduction	2
Safety	2
Features and Controls	7
Preparing The Portable Light Tower For Use	8
Transporting.....	8
Operation	10
Maintenance	17
Specifications	18
Troubleshooting	18

Introduction

About This Manual

TAKE TIME TO READ THIS MANUAL THOROUGHLY

This instruction manual provides necessary instructions for the Night-Lite™ E-Series portable light tower.

The information found in this manual is in effect at the time of printing. Allmand Bros Inc. may change contents without notice and without incurring obligation.

Any reference in this manual to left or right shall be determined by looking at the unit from the control box end.

If uncertain about any of the information in the manual, contact Allmand service department at 1-800-562-1373, or contact us through the Allmand website, www.allmand.com.

Save these original instructions for future reference.



Products Covered by This Manual

The following products are covered by this manual:

Night-Lite™ E-Series

Safety

Safety Definitions

For your safety, the safety of others, and to protect the performance of equipment, follow the precautions listed throughout the manual before operation, during operation and during periodic maintenance procedures.



Indicates a potential personal injury hazard.



DANGER

Indicates a hazardous situation which, if not avoided, **will** result in death or serious injury.



WARNING

Indicates a hazardous situation which, if not avoided, **could** result in death or serious injury.



CAUTION

Indicates a hazardous situation which, if not avoided, **could** result in minor or moderate injury.

NOTICE

Information considered important but not hazard related.

Safety Precautions

The following section contains general safety precautions and guidelines that must be followed to reduce risk to personal safety. Special safety precautions are listed in specific procedures. Read and understand all of the safety precautions before operating or performing repairs or maintenance.



Electrocution Hazard

- Always check overhead wires and obstructions before raising or lowering the light tower.
- Always follow the rules or instructions for your work site and state, province and national electric code for maintaining a safe distance from overhead wires.
- Do not operate the portable light tower if the insulation on the electrical cord or other electrical wiring is cut or worn or if bare wires are exposed. Repair or replace damaged wiring before operating the unit..



Unsafe Operation Hazard

- Never permit anyone to install or operate the equipment without proper training.
- Read and understand this Operator's Manual before operating or servicing the portable light tower to ensure that safe operating practices and maintenance procedures are followed.
- Safety signs and decals are additional reminders for safe operating and maintenance techniques.



Fall Hazard

- Never carry riders on the equipment.



Modification Hazard

- Never modify the equipment without written consent of the manufacturer. Any modification can effect the safe operation of the equipment.



Exposure Hazard

- Always wear personal protective equipment, including appropriate clothing, gloves, work shoes, and eye and hearing protection, as required by the task at hand.



Tipover Hazard

- Do not raise, lower or use the light tower unless all outriggers and jacks are positioned on firm ground.
- Never move or reposition the portable light tower while the light tower mast is extended in the vertical position.



Alcohol And Drug Hazard

- Never operate the portable light tower while under the influence of alcohol or drugs, or when ill.



Flying Object Hazard

- Always wear eye protection when cleaning the equipment with compressed air or high pressure water. Dust, flying debris, compressed air, pressurized water or steam may injure your eyes.



WARNING



Burn Hazard

- Light fixtures become very hot during operation and shortly after shut-down.
- Handle hot components, such as light fixtures, with heat resistant gloves.

NOTICE

- Any part which is found defective as a result of inspection or any part whose measured value does not satisfy the standard or limit **MUST** be replaced.
- Always tighten components to the specified torque. Loose parts can cause equipment damage or cause it to operate improperly.
- The use of authorized replacement Allmand parts is encouraged. The warranty does not cover damage or performance problems caused by the use of parts that are not authorized replacement parts.
- Clean all accumulated dirt and debris away from the body of the equipment and its components before you inspect the equipment or perform preventative maintenance procedures or repairs. Operating equipment with accumulated dirt and debris will cause premature wear of equipment components.
- Retrieve any tools or parts that may have dropped inside of the equipment to avoid improper equipment operation.

Safety Decals

Before operating your unit, read and understand the following safety decals. The cautions, warnings, and instructions are for your safety. To avoid personal injury or damage to the unit, understand and follow all the decals.

Keep the decals from becoming dirty or torn, and replace them if they are lost or damaged. Also, if a part needs to be replaced that has a decal attached to it, make sure to order the new part and decal at the same time.



WARNING

If any safety or instructional decals become worn or damaged, and cannot be read, order replacement decals from your dealer.

Compare Figure 1 with the table following.

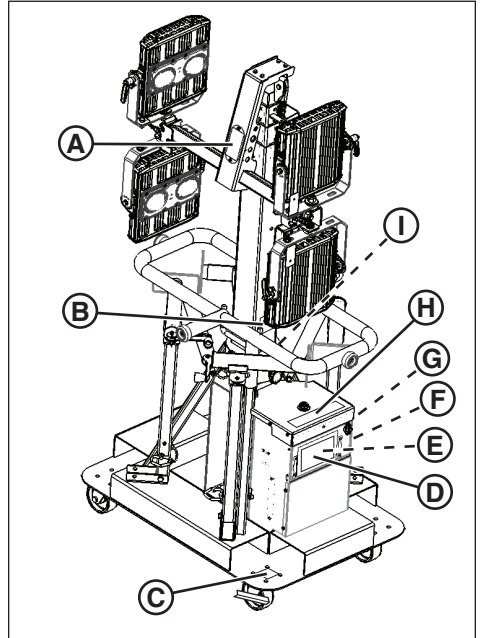

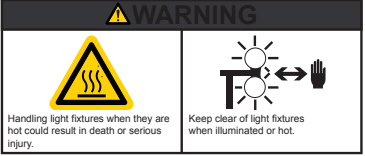

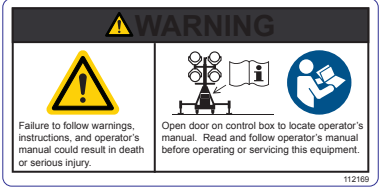

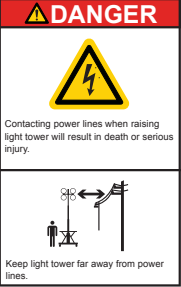
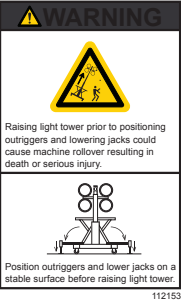
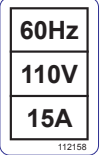

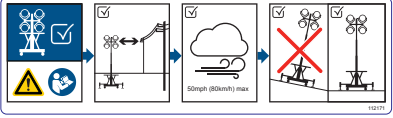
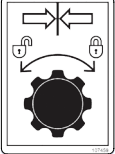









Figure 1

<p>A DANGER - Shut down equipment before entering electrical compartment.</p> <p>Part No. 109011</p> <p>Location: Light Bar</p> <p>Qty: 1</p>	
<p>B WARNING - Keep bystanders away from light tower during lowering and raising operations.</p> <p>Part No. 112148-1</p> <p>Location: Light Tower Mast</p> <p>Qty: 2</p>	
<p>B WARNING - Keep clear of light fixtures when illuminated or hot.</p> <p>Part No. 112148-2</p>	
<p>B WARNING - Do not look directly at illuminated light fixtures.</p> <p>Part No. 112148-3</p>	
<p>C Forklift Pocket</p> <p>Part No. 107254</p> <p>Location: Unit Base</p> <p>Qty: 4</p>	
<p>D WARNING - Read and follow operator's manual before operating or servicing this equipment.</p> <p>Part No. 112169</p> <p>Location: Control Panel Door (outside)</p> <p>Qty: 1</p>	

<p>E DANGER - Shut down equipment before entering electrical compartment.</p> <p>Part No. 112153-1</p> <p>Location: Control Panel Door (inside)</p> <p>Qty: 1</p>	
<p>E DANGER - Maintain safe distance from power lines when raising light tower.</p> <p>Part No. 112153-2</p>	
<p>E WARNING - Position outriggers and lower jacks on a smooth, flat, and stable surface before raising light tower.</p> <p>Part No. 112153-3</p>	
<p>F Electrical Specs</p> <p>Part No. 112158</p> <p>Location: Control Box (right)</p> <p>Qty: 1</p>	
<p>G Power Outlet</p> <p>Part No. 112154</p> <p>Location: Control box (right)</p> <p>Qty: 1</p>	
<p>H Setup Instructions</p> <p>Part No. 112171</p> <p>Location: Control Box (top)</p> <p>Qty: 1</p>	
<p>I Light Tower Transport Alignment</p> <p>Part No. 107459</p> <p>Location: Control Box (top)</p> <p>Qty: 1</p>	

Operation Icons

The following table contains operation icons that may be found on the unit, along with the meaning of each icon.

Icon	Meaning
	On (Power)
	Off (Power)
	Tower Raise / Lower
	Tower Light
	Timer / Manual Mode
	Photocell Mode
	Main Circuit Breaker

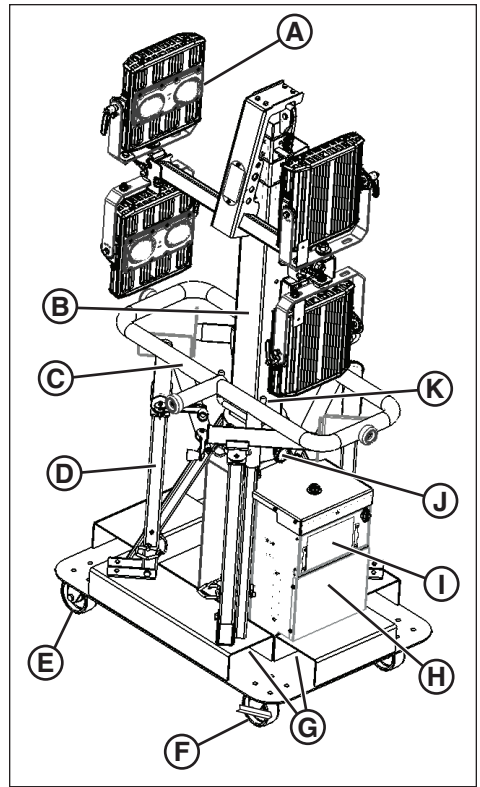

Figure 2

Features and Controls

The Allmand Night-Lite™ E-Series is intended for use as a stationary lighting device to illuminate large areas.

Identify the features and controls of the machine by comparing Figures 2 and 3 with the tables following. See **Operation** for detailed information on each feature / control.

Ref	Description
A	LED Fixture (4 qty)
B	Light Tower Mast
C	Bumper Assembly
D	Outrigger & Jack (4 qty)
E	Caster (2 qty)
F	Caster w/Brake (2 qty)
G	Forklift Pockets (8 qty)
H	Control Box
I	Control Panel Door / Latch
J	Light Tower Mast Lock Knob
K	Light Tower Mast Rotate Handle

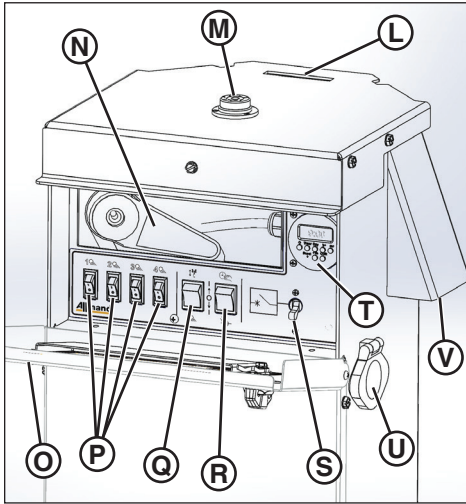

Figure 3

Ref	Description
L	Photocell
M	Level
N	Remote Tower Control
O	Control Panel Door / Latch
P	Tower Light Switches (4 qty)
Q	Tower Raise / Tower Light Switch
R	Light Operation Mode Switch
S	Main Circuit Breaker
T	Timer Module
U	120-Volt Power Plug
V	Control Box Vent

Preparing The Portable Light Tower For Use

If the unit has been stored or idle for a period of time, follow these steps to prepare the portable light tower for use.

WARNING

Operating a machine with worn, damaged or missing parts can result in death or serious injury. Always replace worn, damaged or missing parts promptly. Do not operate this machine until all worn, damaged or missing parts have been replaced, and proper operation of the machine has been verified.

NOTICE

The use of authorized replacement Allmand parts is encouraged. The warranty does not cover damage or performance problems caused by the use of parts that are not authorized replacement parts.

1. Check that a copy of the Operator's Manual is with the portable light tower (on the inside of the control panel door).
2. Check that all safety decals are legible and in place on the portable light tower. See **Safety Decals** in the **Operator Safety** section.
3. Check that the outriggers and jacks operate properly, and that each one is secured in the transport position. See **Leveling and Stabilizing the Light Tower** in the **Operation** section.
4. Check that each of the light fixtures illuminates properly. See **Operating The Tower Lights** in the **Operation** section.
5. Check that the light tower mast raises and lowers properly. See **Raising and Lowering the Light Tower Mast**.

Transporting

Transport Position

Before transporting, make sure that the portable light tower is in the transport position (Figure 4):

1. Lower the light tower mast completely. See **Raising and Lowering the Light Tower Mast**.
2. Place the outrigger jacks in the stowed position. See **Stowing Outriggers and Jacks**. Make sure that the jacks are rotated so that the jack foot is toward the center of the unit.

3. Align the light tower mast tab with the indicator decal on the right side of the unit. Tighten the light tower mast lock knob securely. See **Rotating the Light Tower Mast**.

4. Pull the light arm pin, and rotate the light arm until the light fixtures are vertical as shown in Figure 4. Make sure that the locking pin engages one of the holes after adjusting. Repeat for the other light arm. See **Adjusting the Light Fixtures**.

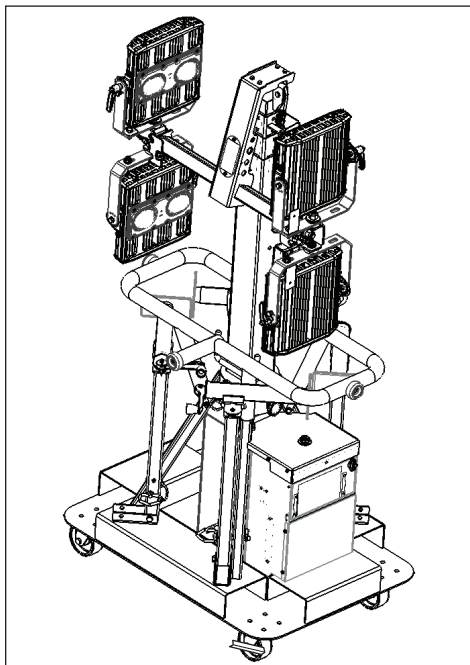

Figure 4

Lifting The Light Tower

WARNING

Attempting to lift the portable light tower with a lifting device that is underrated or damaged could result in death or serious injury. Always make sure the lifting device is rated to lift the weight of the portable light tower. Make sure the lifting device is not damaged and is in operable condition before beginning the lift.

WARNING

Standing or walking under elevated equipment could result in death or serious injury. When elevating or lifting the portable light tower, always keep clear of the area around and under the light tower, and do not allow others in the area.

General Lifting Guidelines

- Before lifting, turn off the lights, lower the light tower mast and disconnect the power cord.
- Always be sure the lifting device you are using is in good condition and rated to exceed the weight of the portable light tower. See **Specifications**.
- Always acquire assistance when using a forklift and when unloading.
- Do not stand or walk under the unit when lifted. Keep others away.

Lifting The Portable Light Tower With A Forklift

The portable light tower is equipped with two sets of forklift pockets: one on either side of the unit (A, Figure 5), and one on the front and back of the unit (B).

Use a forklift with a rated lifting capacity greater than the weight of the portable light tower trailer. See **Specifications**.

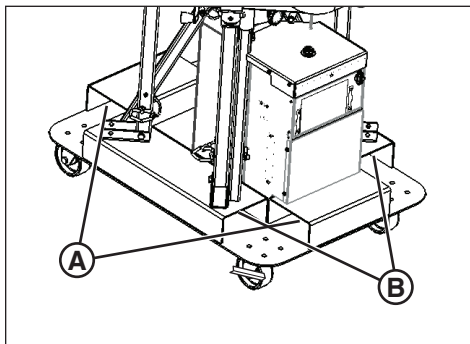

Figure 5

Transporting On A Trailer

The forklift pockets on the unit base can be used as tie-down points.

Always secure the portable light tower with appropriate chains or straps.

The truck operator is responsible for securing the load properly to his transporting trailer.

Operation

Before performing any operation procedures, read **Safety**.

Work Site Safety Considerations

It is the operator's responsibility to ensure that the portable light tower is properly and safely positioned at the work site. Follow state, province and federal rules, as well as rules or instructions for the work site.

Height

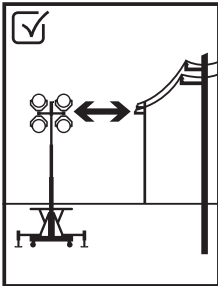

Electrocution Hazard

- Raising the light tower mast in the presence of electrical power lines will result in death or serious injury. Always check for overhead wires and obstructions before raising or lowering the light tower mast.
- Always follow the rules or regulations for your worksite, and state, province and national electric code for maintaining a safe distance from overhead wires.

The work site must be clear of overhead obstructions such as power lines, trees, etc. Keep in mind the maximum height of the light tower mast when fully raised. See **Specifications**.

Ground Surface

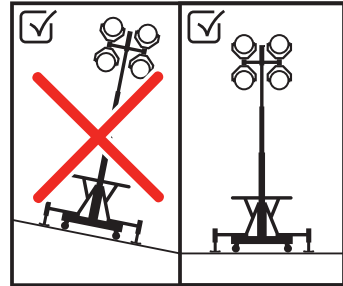

Tipover Hazard

Positioning the portable light tower on soft, unstable or unlevel ground could cause the unit to tip over, resulting in death or serious injury. Always position the unit on a firm, level and stable surface and deploy the outriggers before raising the light tower.

- Do not set up the portable light tower on an incline of more than 2.8° (5% grade) front-to-back and side-to-side.
- Do not position or set up the portable light tower on unlevel or unstable ground. Set up on smooth, flat and firm ground surfaces only.

Wind

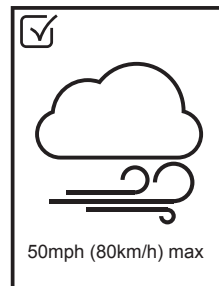



WARNING



Tipover Hazard

Operating with the light tower mast raised in winds exceeding 50 mph (80 km/h) could cause the unit to tip over, resulting in death or serious injury. Do not operate with the light tower mast raised in winds exceeding 50 mph (80 km/h).

When the portable light tower is in the operating position it is located in the middle of a four-point outrigger system for optimum balance and stability. This system was engineered to allow the light tower to remain operational in sustained winds of 50 mph (80 km/h) with the light tower mast extended to full height and the outriggers in position on a firm, level surface.

Leveling and Stabilizing the Portable Light Tower



WARNING



Tipover Hazard

Positioning the portable light tower on soft, unstable or unlevel ground could cause the unit to tip over, resulting in death or serious injury. Always position the unit on a firm, level and stable surface and deploy the outriggers before raising the portable light tower.

1. Position the portable light tower on an adequate work site. See **Work Site Safety Considerations**. Use the level as a guide to locate a level surface: When the bubble (B, Figure 6) is in the top center of the level (A), the unit is level.

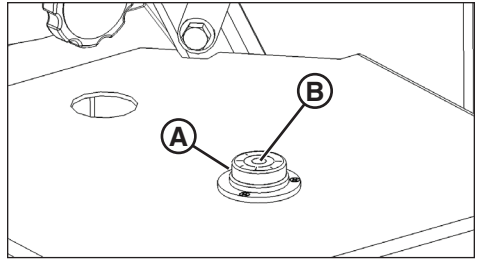

Figure 6

2. Block each caster with a suitable wheel chock.
3. Deploy all four outriggers. See **Deploying the Outriggers and Jacks**.

Deploying the Outriggers and Jacks



WARNING



Tipover Hazard

Failure to deploy the outriggers before raising the light tower mast could cause the light tower to tip over, resulting in death or serious injury. Always deploy the outriggers before raising the light tower.

To deploy the outriggers and jacks:

1. Remove the hair pin cotter (A, Figure 7) and outrigger locking pin (B).
2. Lower the outrigger (C, Figure 7) into the operating position as shown, and lock in the operating position with the outrigger locking pin. Secure the outrigger locking pin with the hair pin cotter.
3. Remove the stabilizer jack locking pin (D, Figure 7). Rotate the jack into the operating position (E). Install the stabilizer jack locking pin fully through the top and bottom holes in the jack and outrigger.
4. Unfold the handle (F, Figure 7) of the stabilizer jack. Turn the handle counter-clockwise to lower the jack foot (G) firmly onto the work site surface.

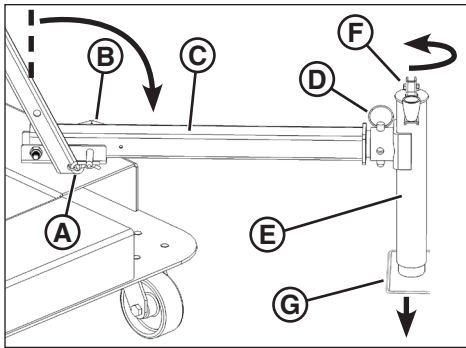

Figure 7

5. Repeat for the remaining outriggers and stabilizer jacks.
6. Level the portable light tower front to back and side to side with the jacks, using the level as a guide.

To stow the jacks and outriggers:

1. Make sure that the lights are shut down and the light tower mast is completely lowered.



Tipover Hazard

Failure to lower the light tower mast before stowing the outriggers could cause the light tower to tip over, resulting in death or serious injury. Always lower the light tower mast before stowing the outriggers.

- 2 Fully raise the stabilizer jack foot by turning the jack handle clockwise.
3. Fold the handle.
4. Remove the stabilizer jack locking pin, rotate the jack into the transport position, and install the stabilizer jack locking pin fully through the top and bottom holes in the jack and outrigger.
5. Remove the hair pin cotter and outrigger locking pin. Raise the outrigger into the transport position, and lock in the transport position with the outrig-

ger locking pin. Secure with the hair pin cotter.

6. Repeat for the remaining stabilizer jacks and outriggers.

Preparing To Operate The Unit

Follow these steps to prepare the portable light tower for operation:

1. Level the portable light tower. See **Leveling And Stabilizing The Portable Light Tower.**
2. Connect a heavy-duty, exterior-use power cord (15 amp) from the power outlet on the side of the unit (A, Figure 8) to a 120-volt AC power source. See **Specifications.**

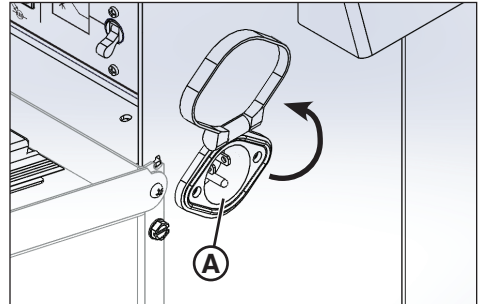

Figure 8

Portable Light Tower Operation

Adjusting The Lights



Burn Hazard

- Adjusting the lights while illuminated could result in death or serious injury. Always adjust the lights with the unit shut down.



WARNING



Burn Hazard

- The light fixtures become extremely hot during use.
- Always use caution and heat-resistant glove when handling the lights or allow the lights to sufficiently cool down before handling.

Adjusting The Light Fixtures

NOTE: The light fixtures must be adjusted before raising the light tower.

1. Shut down the unit. See **Operating The Tower Lights**. Wait 10 minutes for the lights to cool.
2. Pull the light arm locking pin (**A**, Figure 9) to rotate the light arm on each side of the light bar (**B**). Make sure that the locking pin engages one of the holes after adjusting.
3. Grasp and swivel the fixture yoke (**C**, Figure 9) to adjust each fixture side to side.
4. Pull the light fixture locking pin (**D**, Figure 9) to adjust each fixture up or down. Make sure that the locking pin engages one of the holes after adjusting.
5. When lighting operations are complete, adjust the light fixtures to the transport position. See **Transport Position**.

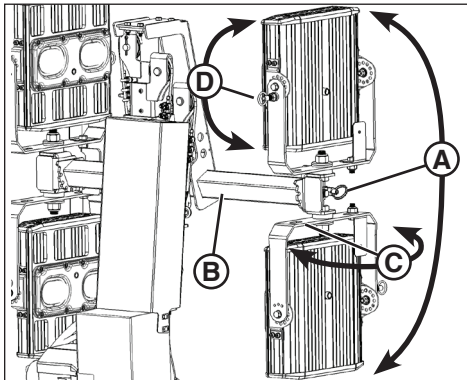

Figure 9

Rotating The Light Tower Mast



CAUTION

Rotating the light tower mast will cause the light fixtures to swing, and could result in minor to moderate injury. Be careful to rotate the tower slowly, and be aware of the light fixtures while rotating the tower.

1. Shut down the lights. See **Operating The Tower Lights**. Wait 10 minutes for the lights to cool.
2. Loosen the light tower mast lock knob (**A**, Figure 10).
3. Use the handles (**B**, Figure 10) to rotate the light tower mast in the desired direction.
4. Tighten the light tower mast lock knob.



WARNING

Failure to tighten the light tower mast lock knob could cause the light fixtures to swing inadvertently, especially in windy conditions or during transport, and could result in death or serious injury. Always tighten the light tower mast locking knob securely after rotating the light tower mast.

5. When lighting operations are complete, rotate the light tower mast to the transport position: Align the light tower mast tab (**C**, Figure 10) with the front center of the light tower base. Tighten the light tower mast lock knob securely. See also **Transport Position**.

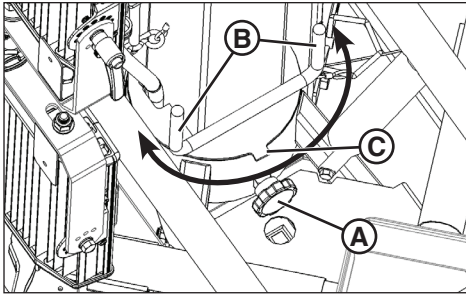

Figure 10

Raising and Lowering The Light Tower Mast



Electrocution Hazard

- Raising the light tower mast in the presence of electrical power lines will result in death or serious injury. Always check overhead wires and obstructions before raising or lowering the light tower mast.



Tipover Hazard

- Before raising, lowering or operating the tower lights, the unit must be set up, properly leveled and stabilized. See **Pre-Operation Setup**.



Crush Hazard

- Standing under the light tower mast while raising or lowering could result in death or serious injury. Make sure that there are no persons near the portable light tower when raising or lowering the light tower mast.

Raising the Light Tower Mast

1. Before raising the light tower mast, adjust the tower lights to the desired work position. See **Adjusting The Lights**.

2. Unlatch and open the control panel door (A, Figure 11).
3. Turn the main circuit breaker (B, Figure 11) to the ON position.
4. Turn the Tower / Light switch (C, Figure 11) to the TOWER position.
5. Remove the remote tower control (D, Figure 11) from the control panel and stand back from the unit base.

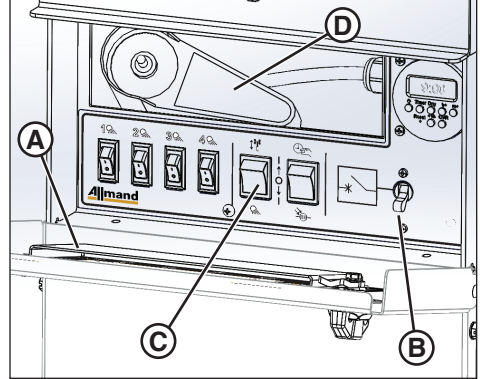

Figure 11

6. Move the remote tower control switch to the UP position until the tower is fully raised (A, Figure 13).
7. Remove the hair pin cotter (A, Figure 12) and tower mast locking pin (B) from the stowing hole shown in Figure 12. Insert the tower locking pin in the locking hole (C), and secure with the hair pin cotter.

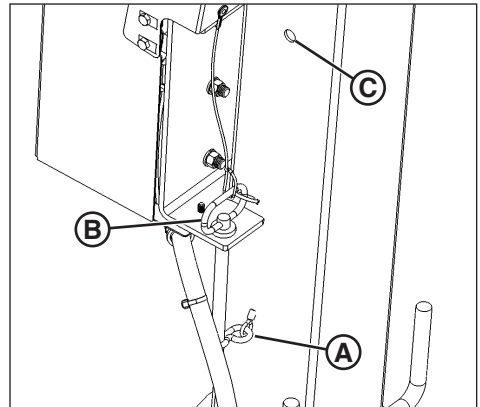

Figure 12

Lowering the Light Tower

1. Shut down the lights. See **Operating The Tower Lights**.
2. Remove the hair pin cotter and tower locking pin from the hole in the tower. Place the tower locking pin in the stowing hole and secure with the hair pin cotter. See Figure 12.
3. Turn the Tower / Light switch (C, Figure 11) to the TOWER position.
4. Remove the remote tower control (D, Figure 11) from the control panel and stand back from the unit base.
5. Move the remote tower control switch to the DOWN position until the tower is fully lowered (B, Figure 13).

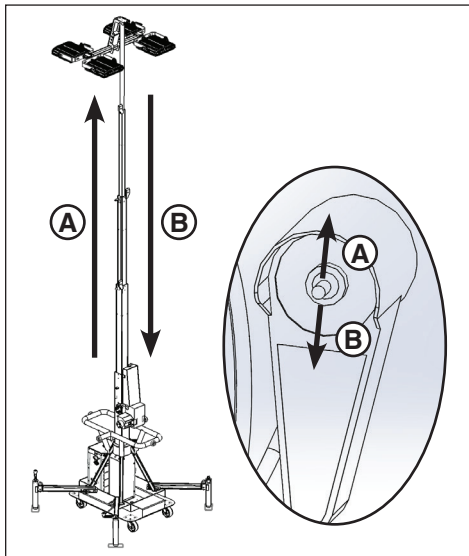

Figure 13

Operating The Tower Lights



WARNING

Looking at illuminated light fixtures could result in serious injury. Never look directly at illuminated light fixtures.

Turning The Lights On

1. Unlatch and open the control panel door.

2. Turn the main circuit breaker (A, Figure 14) to the ON position.
3. Select the preferred mode of operation: Timer / Manual or Photocell. See **Light Operation Mode**.
4. Turn the Tower / Light switch (B, Figure 14) to the LIGHT position.
5. Turn the individual light switches (C, Figure 14) (1 - 4) to ON (if set to OFF).

NOTE: If the mode of operation is set to Photocell or Timer, the lights will not come on until dark (photocell) or until the time selected (timer).

Turning The Lights Off

- If in Manual Mode, turn manual mode off. See **Light Operation Mode**.
- If in Photocell or Timer mode, the lights will turn off automatically in ambient light (photocell) or at the time selected (timer).

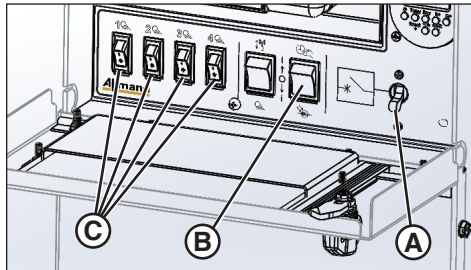

Figure 14

Light Operation Mode

The tower lights can be controlled manually, by photocell, or by timer.

Manual Operation

1. Turn the Photocell / Timer switch (B, Figure 15) to the TIMER position.
2. Press the OVR button (G, Figure 15) on the timer module to turn on Manual mode. Press again to turn off.

Photocell Operation

Turn the Photocell / Timer switch (B, Figure 14) to the PHOTOCCELL position.

The lights will automatically come on in the absence of ambient light.

NOTE: For most consistent operation, avoid locating the unit in a shadowed area, and orient the unit so the control box faces north or south.

Timer Operation

Turn the Photocell / Timer switch (B, Figure 13) to the TIMER position.

To set the timer:

1. Reset the timer module (first time use):
 - a. With a blunt object press and release the Reset button (I, Figure 14). The timer screen (C) will flash.
 - b. Press the Clock (A, Figure 14) and Hour (E) buttons simultaneously. The time will reset to 12:00am.
2. Set the clock:
 - a. If currently in Daylight Savings Time, press the +1h button (H, Figure 14). (If not, bypass this step.)
 - b. Press and hold the Clock button (A, Figure 14) while simultaneously pressing the Day (D), Hour (E) and/or Minute (F) buttons until the correct day and time appears.
3. Set the Timer
 - a. Timer On:
 - Press the Timer button (B, Figure 14) once. ON will appear to the left of the display.
 - Press the Day button (D, Figure 14) repeatedly to turn on or off each day the timer will turn on.
 - Press the Hour (E, Figure 14) and Minute (F) buttons until the desired time for the timer to turn on appears.
 - b. Timer Off:
 - Press the Timer button (B, Figure 14) again. OFF will appear to the left of the display.

- Press the Day button (D, Figure 14) repeatedly to turn on or off each day the timer will turn off.
- Press the Hour (E, Figure 14) and Minute (F) buttons until the desired time for the timer to turn off appears.

- c. The timer can be set for seven different events. Repeat Steps 3a and 3b as needed. The number of the timer event is displayed next to the timer ON / OFF display.

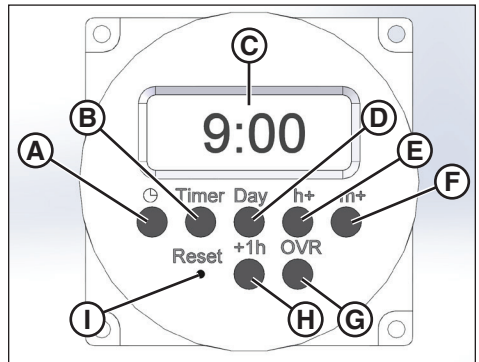

Figure 14

Unit Shutdown

Once lighting operations are complete at the work site, perform unit shutdown:

1. Shut down the lights. See **Operating The Tower Lights**.
2. Wait 10 minutes for the lights to cool.
3. Lower the light tower mast. See **Raising And Lowering The Light Tower Mast**.
4. Retract the outriggers. See **Leveling And Stabilizing The Portable Light Tower**.
5. Rotate the light tower mast to the transport position. See **Adjusting The Lights**.
6. Adjust the light fixtures to the transport position. See **Adjusting The Lights**.
7. Store the remote tower control.

8. Close and latch the control panel door.
9. Disconnect the power cord from the 120-volt power source and the power outlet on the side of the unit.
10. Remove the wheel chocks from the wheels of the unit.

The unit is now ready for transport. See **Transporting**.

WARNING

- Do not remove the wheel chocks from the front and back of the wheels until the portable light tower is ready to be transported. Doing so could result in death or serious injury.

Maintenance

Before performing any maintenance procedures, read **Safety**.

Where equipment is operated under severe conditions (very dusty, extreme heat or cold, etc.), affected items should be serviced more frequently.

WARNING

Operating a machine with worn, damaged or missing parts can result in death or serious injury. Always replace worn, damaged or missing parts promptly. Do not operate this machine until all worn, damaged or missing parts have been replaced, and proper operation of the machine has been verified.

General Maintenance

1. Inspect the light tower mast, cables, light fixtures, frame, and all components for wear, damage or corrosion. Repair or replace as needed.
2. Check to be sure all hardware is securely tightened.
3. Inspect the wheels for wear or damage. Replace as needed.

4. Inspect the outrigger bars, stabilizer jacks and locking pins for proper operation, and for wear, damage or corrosion. Replace as needed.

Cleaning



Entanglement Hazard

- Failure to disconnect the power before cleaning the unit could result in death or serious injury. Always disconnect the power before cleaning the unit.



Burn Hazard

- Shut down the lights and allow ample time for components to cool before cleaning the unit. Failure to do so could result in serious burns.

NOTICE

Use caution when using compressed air or water / steam pressure washers. Do not pressure-clean electrical components, as this may cause damage.

- Clean the portable light tower to remove all dust, dirt or other foreign material.
- Clean the light fixture assemblies with a damp cloth or sponge.
- Clean all electrical wiring and components by hand using non-corrosive cleaner.
- Open the control panel door and clean the control panel.

Model And Serial Number

Model and serial number information is required for product support and repair parts. The serial number plate for the portable light tower is located on the unit base.

Specifications

Overall Dimensions

Length (Transport position)	45 in (114,3 cm)
Width (Transport position)	32 in (81,3 cm)
Height (Transport position)	89 in (226,1 cm)
Ground Clearance	6 in (15,2 cm)
Height (Tower Extended)	273 in (693,4 cm)
Width (Outriggers deployed)	64 in (162,6 cm)
Length (Outriggers deployed)	70 in (177,8 cm)
Unit Weight	720 lbs (325 kg)
Wind Speed	50 mph (80 km/h)
Frequency (Hz)	60
Volts	120
Amps	14

Troubleshooting

Before performing any troubleshooting procedures, read **Safety**.



WARNING



Burn Hazard

- The light fixtures become extremely hot during use.
- Always use caution and heat-resistant glove when handling the lights or allow the lights to sufficiently cool down before handling.

Troubleshooting Chart

Problem	Possible Cause
Lights / electric winch not operable	No power. Make sure power cord is connected between unit and 120-volt supply.
	Main breaker off. Turn on main breaker.
No light (one or more lights)	Light switch(es) off. Turn on light switch(es).
	Tower / Light switch in Tower position. Turn switch to Light position.
Photocell / Timer and Manual control not working	Light Operation Mode not set correctly. See Light Operation Mode .
Photocell stays on or does not function properly	Too little ambient light. Make sure that nothing is blocking photocell. See Photocell Operation . Or switch to Timer or Manual control.
	Low voltage. Power cord gauge too small or length too long.
Photocell stays off or does not function properly	Too much ambient light. Move away from light, or switch to Timer or Manual control.
Electric winch not working	Tower / Light switch in Light position. Turn switch to Tower position.
Unit not working	Unit malfunction. Contact authorized dealer.

