

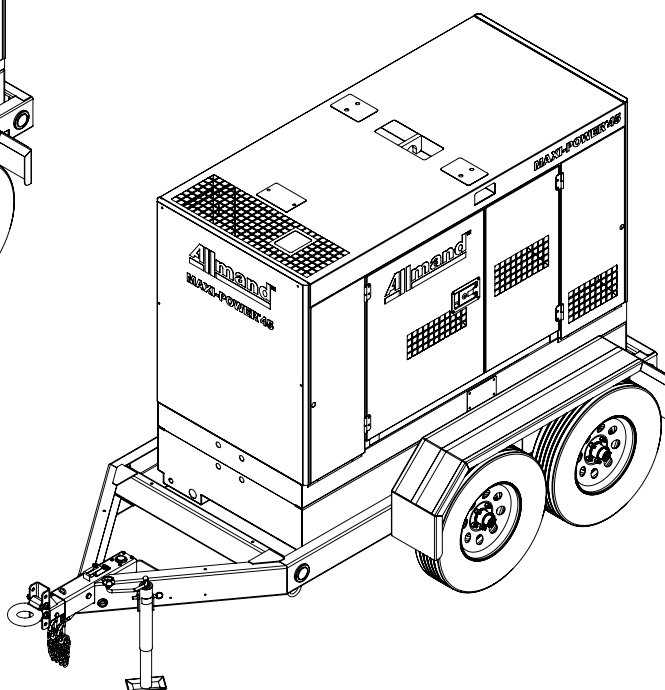

en **Operator's Manual**
Maxi-Power™ Towable Generator
MP25 (25 kVA)
MP45 (45 kVA)

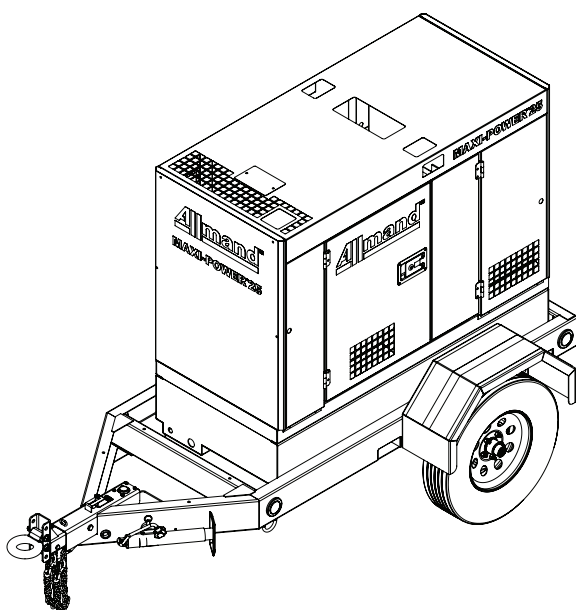

Thank you for purchasing this quality-built Allmand towable generator. We are pleased that you've placed your confidence in the Allmand brand. When operated and maintained according to the instructions in this manual, your Allmand generator will provide many years of dependable service.

This manual contains safety information to make you aware of the hazards and risks associated with towable generators and how to avoid them. Because Allmand does not necessarily know all the applications this towable generator could be used for, it is important that you read and understand these instructions thoroughly before attempting to start or operate this equipment. **Save these original instructions for future reference.**

Where to Find Us

If you have any questions about the machine, contact your authorized dealer. You can also contact Allmand Customer Service by phone at **(800) 562-1373**, or on the Internet at **allmand.com**.

Knowing the model number of your Allmand Generator will make it easy to order maintenance or repair parts either online or from your local dealer. The model number is generally a number stamped into metal or on a sticker directly on your product.

Towable Generator

Model Number _____

Revision _____

Serial Number _____

Date Purchased _____

Engine

Model Number _____

Type Number _____

Code Number _____

Table of Contents

Operator Safety	4
Features and Controls	8
Transporting and Set-Up	12
Operation	15
Maintenance	28
Storage	38
Troubleshooting	39
Specifications	41
Wiring Diagram	43
Piping Diagram	47
Operation Log	48
Addendum A - Cam Locks / Arctic Kit.	49
Addendum B - Misc Unit Options	50
Addendum C - Tire Safety Information	51

Operator Safety

Equipment Description



Read this manual carefully and become familiar with your towable compressor. Know its applications, its limitations, and any hazards involved.

Every effort has been made to ensure that information in this manual is accurate and current. Figures and drawings in this manual may differ slightly from your model. However, we reserve the right to change, alter, or otherwise improve the product and this document at any time without prior notice.

Safety and Control Symbols

The safety alert symbol  indicates a potential personal injury hazard. A safety symbol may be used to represent the type of hazard. **DANGER** indicates a hazard which, if not avoided, will result in death or serious injury. **WARNING** indicates a hazard which, if not avoided, *could* result in death or serious injury. **CAUTION** indicates a hazard which, if not avoided, *could* result in minor or moderate injury. **NOTICE** indicates information considered important, but not hazard-related.



Operator's Manual



Alert



Organic Waste



Toxic Fumes



Explosion



Clothing



Prohibited



Fire



Hot Surface



Entanglement



Battery



Protective Gear

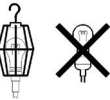

Lighting Apparatus



Explosive Pressure



Safety Equipment



Electrocution Hazard



Rotating Parts



Moving Parts

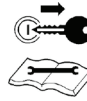

Remove Key Before Maintenance



WARNING



Read and follow safety directions:

- Be sure safety decals are present and legible. Replace if damaged or missing.
- Do not modify machine without prior approval. Machine safety may be compromised, functions may be altered, or machine life may be shortened.
- Never use machine for purposes other than power supply. Death or serious injury could result.



WARNING



VENTILATION!

- Exhaust gas from the engine is poisonous, and could cause death when inhaled.
- Avoid using the machine in an insufficiently ventilated building or tunnel.



WARNING



- Keep flames away from battery.
- Battery may generate hydrogen gas, which is explosive.
- Battery electrolyte is dilute sulfuric acid. Mishandling could result in severe burns.
- When handling battery, be sure to wear appropriate safety protection such as safety goggles and gloves.
- Dispose of battery according to local, state and/or federal regulations.



WARNING



When operating machine, do not wear:

- Loose clothes
- Clothes with unbuttoned sleeves
- Hanging tie or scarf
- Accessories such as dangling jewelry
- Such items could be caught in rotating parts of machine, and could result in death or serious injury.



WARNING

Do not operate machine when tired or under influence of drugs or alcohol. Careless operation could result in death or serious injury.



WARNING



Wear appropriate personal protective equipment (PPE), such as a helmet, safety glasses, earplugs, safety shoes, gloves, and a dust mask.



WARNING



Have first-aid boxes and fire extinguishers near machine in case of emergency such as injury and fires. It is also advisable to have a list of phone numbers of doctors, ambulance and fire department available in case of emergency.



WARNING

To prevent injury, tools, cables, hoods, covers and other unnecessary items should be cleaned and removed from machine before operation.

 **WARNING** 

- Contact with the output terminals and control board could cause electric shock, resulting in death or serious injury. Do not open the cover of the output terminal board during machine operation.
- When removing or connecting a connecting cable for changing load, be sure to switch OFF the circuit breaker, remove the starter key from the starter switch, then perform work.

 **WARNING** 

Contact with rotating parts or belts could cause death or serious injury. Keep hands from rotating parts and belts while machine is in operation.

 **WARNING**  

Do not open radiator cap during or immediately after operation. Explosive pressure of hot liquid could cause severe burns, resulting in death or serious injury.

 **WARNING** 

- Do not touch hot parts.
- Never work nearby hot portions of the machine while it is running.
- Parts such as engine, exhaust manifold, exhaust pipe, muffler and radiator are especially hot. Never touch these parts, as it could result in serious burns.
- Coolant water and engine oil are also very hot and dangerous to touch. Do not check or add while machine is running.

 **WARNING**  

- Fire prevention.
- Fuel and oils are extremely flammable. Do not bring ignition sources near machine when checking or adding fuel and oils.
- Adding fuel and oils should be done outdoors or in a well-ventilated location.
- Refuel after stopping engine, and never leave fuel near machine. Do not spill. If spilled, wipe up completely.
- Do not fill fuel oil up to cap level. Fuel oil will overflow due to volume expansion caused by rise of ambient temperature. Fuel can also spill during machine movement or transporting.
- Parts such as muffler and exhaust pipe can be extremely hot. Remove twigs, dried leaves, dried grass, waste paper, etc. from around muffler and exhaust pipe.
- Keep a fire extinguisher available by machine in case of fire.

 **WARNING** Hang a “Now Checking and under Maintenance” tag:

- Remove starter key from starter switch before starting inspection, and hang up a “Now Checking and under Maintenance” tag where it can be easily

seen. Inspector must keep key during checking and maintenance.

- Remove black negative (-) cable from battery.
- Neglecting above procedure could result in death or serious injury.

 **WARNING**  **Adjusting belt tension:**

- Attempting to adjust belt tension with machine running could result in death or serious injury.
- Stop engine, remove starter key, and remove black negative (-) cable from battery before adjusting belt tension.

 **WARNING**  **Hands off cooling fan:**

- Contact with cooling fan while machine is running could result in death or serious injury.
- Stop engine and remove starter key whenever maintenance is to be performed near cooling fan.

 **WARNING**  Wear safety glasses when cleaning dust accumulated in such devices as air-filter by blowing compressed air.

 **WARNING**  **Lighting apparatus:**

- If work site is dark, use lighting to illuminate work area. Working without illumination could result in death or serious injury.
- Work lighting should be fitted with safety guard to protect against breakage.
- Do not allow work light to contact fuel or oils, as they could ignite, causing death or serious injury.

 **WARNING**  Opening coolant water drain valve cap:

- Stop engine and let coolant water sufficiently cool down before draining.
- If drain valve is opened before coolant water is cooled enough, hot water could jet out, resulting in death or serious injury.

 **CAUTION**  **Refilling or draining engine oil:**

- Engine oil is extremely hot during and just after operation.
- Stop engine and wait 10 to 20 minutes before checking, adding or draining engine oil.

 **CAUTION**  Treatment of organic wastes.

- Waste liquid from machine contains harmful material. Do not discharge onto ground or into rivers, lakes or sea. Such material will contaminate the environment.
- Be sure to use an approved container to hold waste liquid from machine.
- Be sure to follow local, state or federal regulations when disposing of oil, fuel, coolant (antifreeze), filter, battery or other harmful materials.

! WARNING

Breathing diesel engine exhaust exposes you to chemicals known to the State of California to cause cancer and birth defects or other reproductive harm.

- Always start and operate the engine in a well-ventilated area.
- If in an enclosed area, vent the exhaust to the outside.
- Do not modify or tamper with the exhaust system.
- Do not idle the engine except as necessary.

For more information go to www.P65warnings.ca.gov/diesel.

! WARNING

- Battery posts, terminals, and related accessories contain lead and lead compounds, chemicals known

to the State of California to cause cancer, birth defects, or other reproductive harm. Wash hands after handling.

NOTICE

- Parts of this machine contain sensitive electronic components. If welding work is required, disconnect any electronic equipment on the machine to prevent damage due to excessive current.

NOTICE

- When washing the machine, cover the control panel, generator and its electric parts to prevent them from being exposed to splashing water and avoid possible malfunction.
- Dust, sand and dirt accumulated inside control panel could cause instrument malfunction. Clean with compressed air.

Safety Decals and Locations

The following safety decals are attached to the machine. Keep them clean at all times. If they are damaged or missing, contact your authorized dealer for replacements. Part numbers are indicated on the lower right corner of the label. Adhere a new one to the original location.

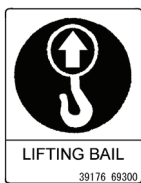

A

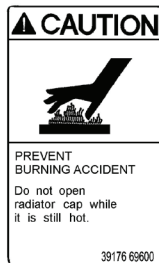

B

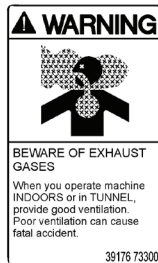

C

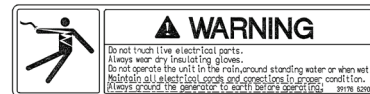

D



E

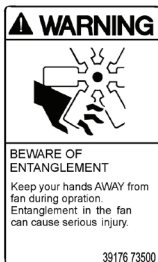

F



G

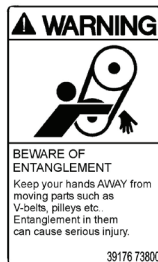

H

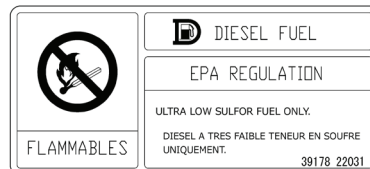

I

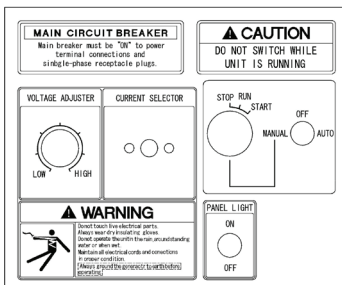

J



K

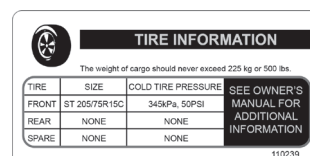

L

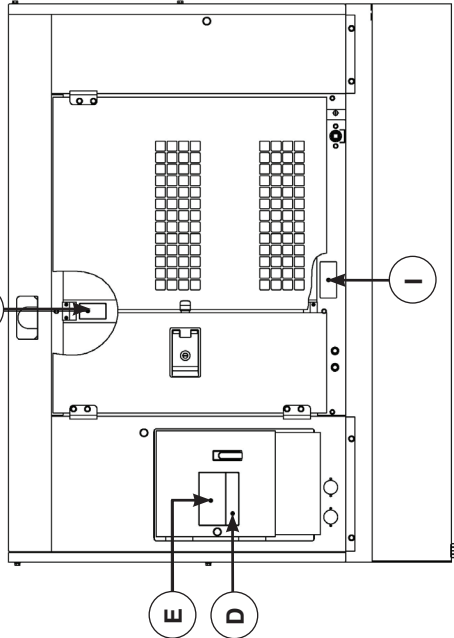
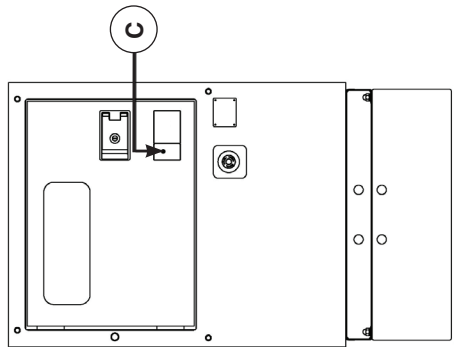
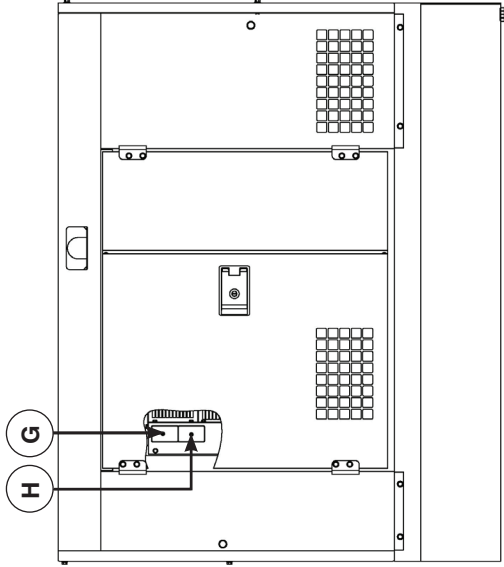
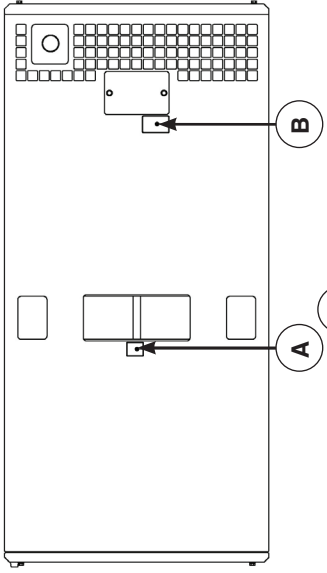
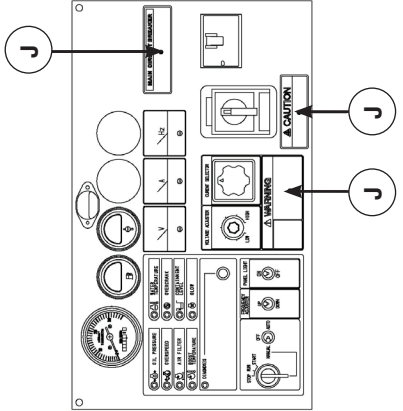
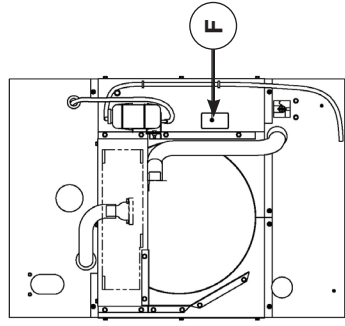
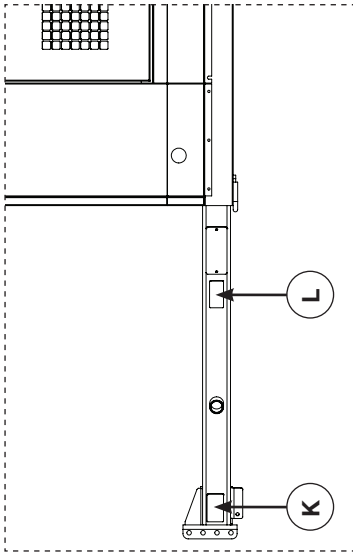

Features and Controls



Read this Operator's Manual and safety rules before operating your towable generator. Compare the illustrations with your towable generator, to familiarize yourself with the locations of various controls and adjustments. Save this manual for future reference.

Internal Components - MP25

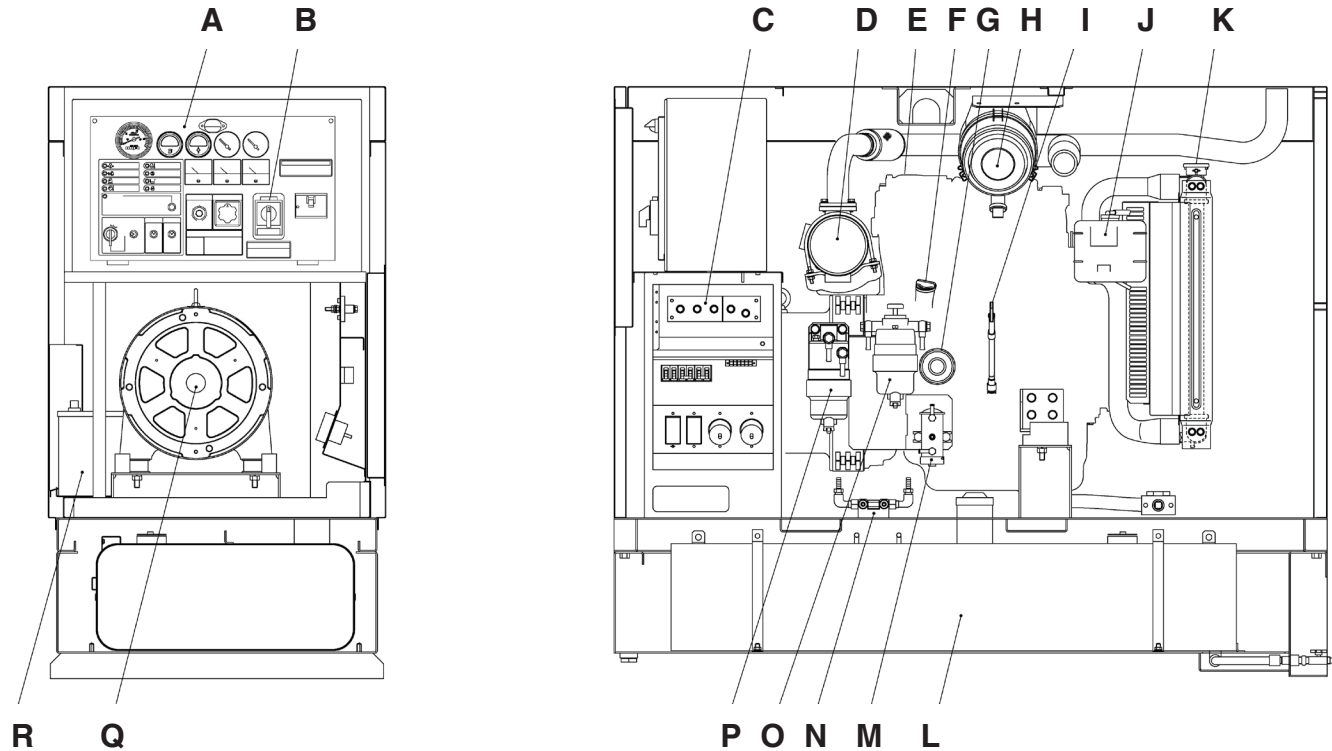

- A - Control Panel** - Controls and monitors various machine functions
- B - Voltage Selector Switch** - Selects output voltage
- C - Output Terminals** - Equipped with three phase and single-phase terminal and receptacle for single phase
- D - DOC (Diesel Oxidation Catalyst)** - Purifies exhaust gases
- E - Engine** - Drives generator
- F - Engine Oil Filler Port** - Location for adding engine oil
- G - Engine Oil Filter** - Filters impurities from engine oil
- H - Air Filter** - Filters impurities from intake air
- I - Engine Oil Level Gauge** - Indicates engine oil level

- J - Reserve Coolant Tank** - Reserve coolant storage
- K - Radiator** - Cools engine
- L - Fuel Tank** - Stores fuel
- M - Fuel Air-Bleeding Electromagnetic Pump** - Automatically bleeds air from fuel pipes
- N - Fuel Pipe Selector Valve** - Selects between fuel supplies
- O - Fuel Filter** - Filters impurities from fuel
- P - Fuel Pre-Filter** - Filters impurities / separates water from fuel
- Q - Generator Main Unit** - Generates AC power
- R - Battery** - Power for starting engine

Internal Components - MP45

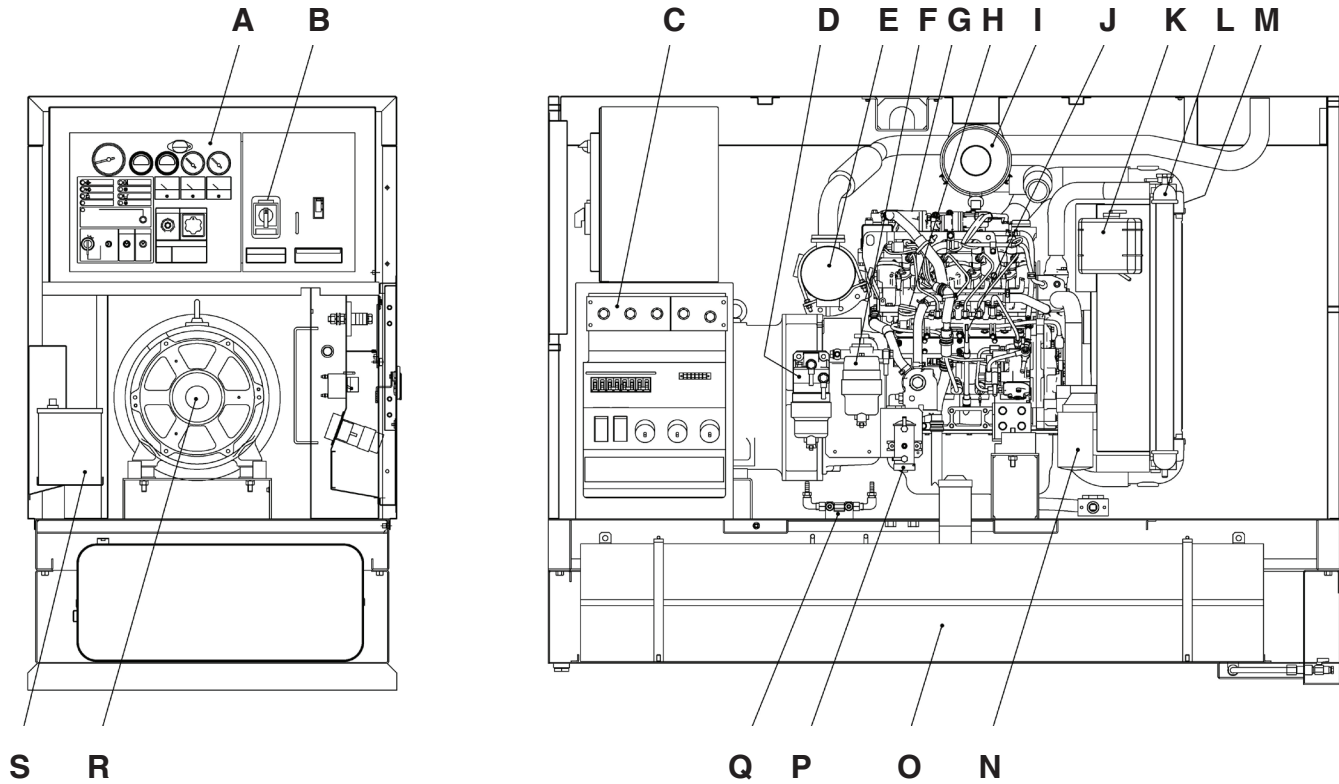

- A - Control Panel** - Controls and monitors various machine functions
- B - Voltage Selector Switch** - Selects output voltage
- C - Output Terminals** - Equipped with three phase and single-phase terminal and receptacle for single phase
- D - Fuel Pre-Filter** - Filters impurities / separates water from fuel
- E - DOC (Diesel Oxidation Catalyst)** - Purifies exhaust gases
- F - Fuel Filter** - Filters impurities from fuel
- G - Engine** - Drives generator
- H - Engine Oil Filler Port** - Location for adding engine oil
- I - Air Filter** - Filters impurities from intake air

- J - Engine Oil Level Gauge** - Indicates engine oil level
- K - Reserve Coolant Tank** - Reserve coolant storage
- L - Radiator** - Cools engine
- M - Intercooler** - Cools air heated by engine
- N - Engine Oil Filter** - Filters impurities from engine oil
- O - Fuel Tank** - Stores fuel
- P - Fuel Air-Bleeding Electromagnetic Pump** - Automatically bleeds air from fuel pipes
- Q - Fuel Pipe Selector Valve** - Selects between fuel supplies
- R - Generator Main Unit** - Generates AC power
- S - Battery** - Power for starting engine

Instrument Panel - MP25

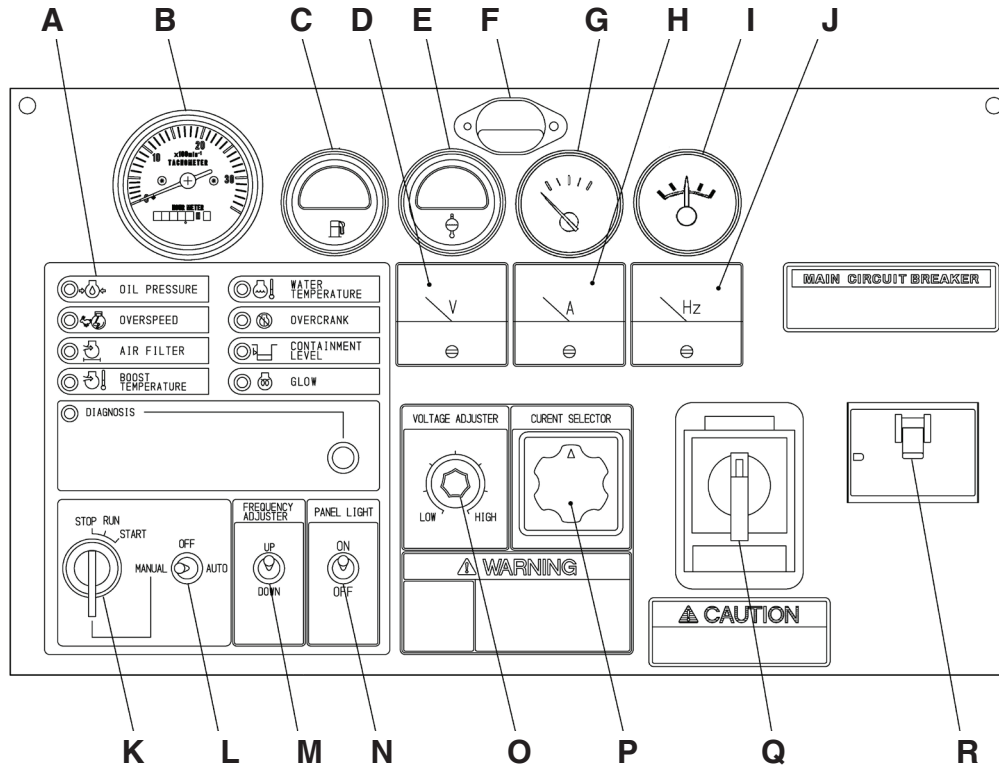

A - Monitor Lamp

B - Tachometer with Hourmeter

C - Fuel Gauge

D - Voltmeter

E - Coolant Temperature Gauge

F - Panel Light

G - Engine Oil Pressure Gauge

H - Ammeter

I - Ammeter for Battery Charge

J - Frequency Meter

K - Starter Switch

L - Manual-Automatic Change-Over Switch

M - Frequency Adjuster Switch

N - Panel Light Switch

O - Voltage Adjuster Switch

P - Ammeter Change-Over Switch

Q - Voltage Selector Switch

R - Main Circuit Breaker

Instrument Panel - MP45

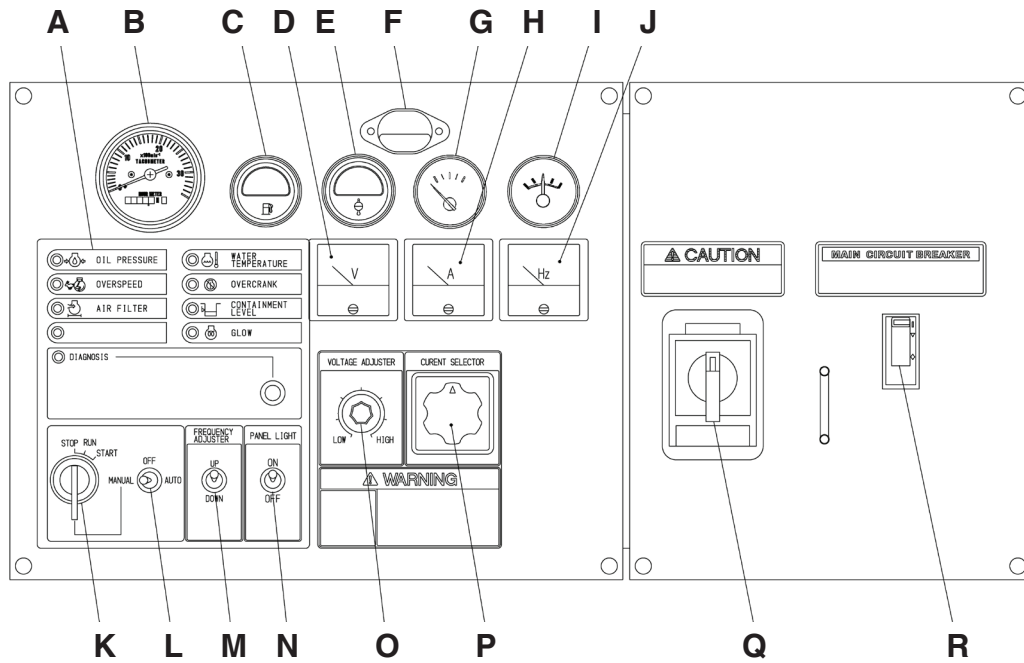

A - Monitor Lamp

B - Tachometer with Hourmeter

C - Fuel Gauge

D - Voltmeter

E - Coolant Temperature Gauge

F - Panel Light

G - Engine Oil Pressure Gauge

H - Ammeter

I - Ammeter for Battery Charge

J - Frequency Meter

K - Starter Switch

L - Manual-Automatic Change-Over Switch

M - Frequency Adjuster Switch

N - Panel Light Switch

O - Voltage Adjuster Switch

P - Ammeter Change-Over Switch

Q - Voltage Selector Switch

R - Main Circuit Breaker

Transporting and Set-Up



Read entire Operator's Manual before you attempt to setup, transport, or operate your new towable generator.

Your towable generator is ready for use after it has been properly setup with the recommended oil and fuel. If you have any problems with the setup of your towable generator, contact your authorized dealer

Transporting



WARNING When loading and unloading the unit, be sure to use the lifting bail (B) located at the top center of the unit.

- Never get under the unit when lifted.
- Never lift the unit while in operation.
- If the unit is transferred by truck, fasten it by ropes at the front eye and rear stand. Also be sure to place a set of chocks against the front and rear of each wheel.

Lifting the Generator

Before lifting the unit, make sure to check the lifting bail for any cracks, loose bolts, etc.

1. Connect the hook (A) of the crane or shackle with the lifting bail (B) eye fitted at the top center of the unit. Ensure there is no person standing around the unit. Then perform hoisting operation.
2. Select a truck or crane with capacity sufficient for the weight and size of the unit. See **Specifications**.
3. Never hang anything from generator while lifting. Bail is designed to carry only weight of generator.

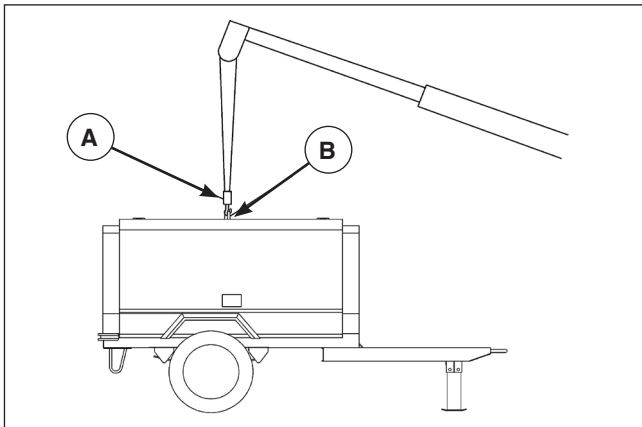

Towing the Generator



WARNING Before towing the machine, make sure to check and confirm the following points. Failure to follow the instructions below, could result in serious injury or death.

- Proper tire air pressure.
- Tire lug nuts are not loose.
- Tires are not worn or damaged. See Addendum B - Tire Safety Information.
- Ensure that the end of the drawbar is securely connected to the coupler of the towing vehicle.

- Ensure there is no damage to the towing vehicle and the drawbar of the machine.
- Be sure to keep hands and fingers away from any part of the coupling device when coupling or uncoupling a drawing device to a draw bar.
- Be sure the height of the hitch is adjusted so that the trailer is level while connected to the tow vehicle.
- Make sure to drive the towing vehicle safely.

Set-Up



WARNING

- Exhaust gas from the engine is poisonous, and could cause death when inhaled.
- Avoid using the machine in an insufficiently ventilated building or tunnel.
- Do not position the exhaust gas outlet in the direction of a person or building.

The machine should be operated in the following conditions:

- Ambient temperature 5°F to 104°F (-5°C to 40°C).
- Humidity less than 85%.
- At altitudes lower than 3,281 ft (1000 meters) above sea level.
- Set up the machine in a place with good ventilation, lower temperature, and with surroundings as dry as possible.
- If more than two machines are placed parallel in operation, keep enough distance so that exhaust air from one machine does not affect the other.
- Set up the unit in an area where fresh air is always available.
- Keep enough space around the unit for inspection and maintenance access.



WARNING The machine must be parked horizontally on a level surface. If the machine must be parked on a slope, place it across the grade to prevent rolling. Do not park on a slope exceeding 15°. Be sure to place wheel chocks (C) against the front and back of each wheel.

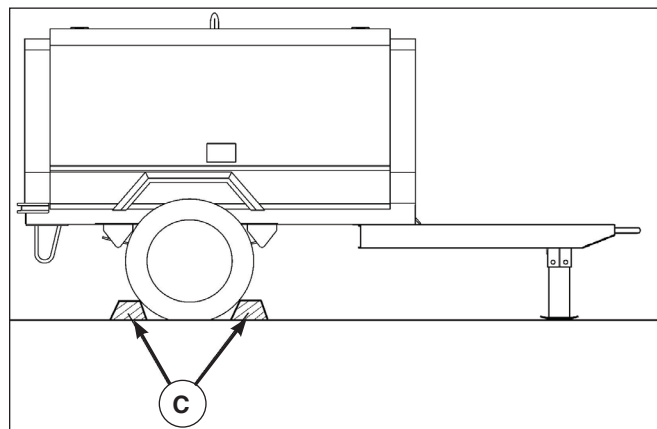

Grounding



WARNING

- Failure to properly ground the unit could result in death or serious injury. Be sure to properly ground the unit before operation.
1. Using a mallet, install a grounding rod (A) firmly into the ground, less than 5 feet from the unit's grounding terminal (B).
 2. Connect the grounding rod cable to the grounding terminal.

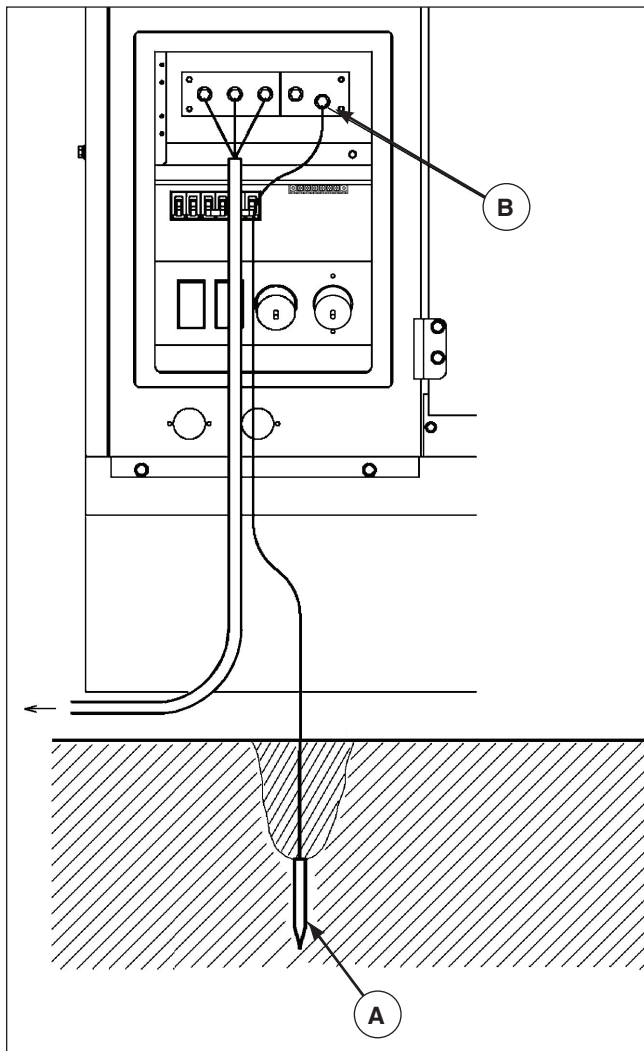

Selecting Cable

- Select a cable (C) with sufficient diameter by considering the permissible current on the cable and the distance from the generator to the load (D).
- If the current flowing to the load exceeds the permissible current of the cable, resultant overheating may burn the cable. Similarly, if the cable is too small in thickness to the length, the input voltage to the load will fall to cause the load input power to drop, as a result, the performance of the machine cannot be displayed.

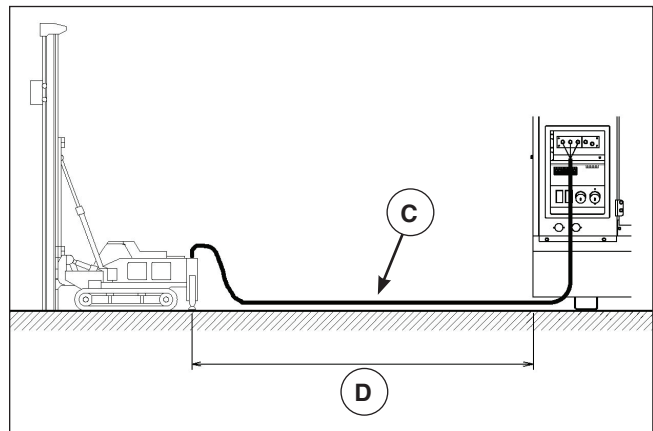

- Below is a simplified three-phase three-wire formula to seek voltage drop or cross-sectional area of the cable from cable length and working current. Select such a cable length and thickness so that the voltage drop will remain less than 5%.

Output system	Voltage drop	Cross-Sectional Area of Cable	e: Voltage drop (V) e ¹ : Voltage drop between outside line or one line of each phase and neutral line
Three-phase 3-wire Type	$e = 30.8 \times L \times I / 1000 \times A$	$A = 30.8 \times L \times I / 1000 \times e$	A: Cable thickness (mm ²)
Three-phase 4-wire Type	$e = 17.8 \times L \times I / 1000 \times A$	$A = 30.8 \times L \times I / 1000 \times e^1$	L: Cable length (m) I: Working current (A)

- The following tables show the relations between the cable length and the cable thickness (nominal cross-sectional area) suited to the working current. (Based on the condition that working voltage is 200 V, with voltage drop of 10V.)

Single-Conductor Cable (Unit: in² (mm²))

Length (ft (m)) / Current	164 (50)	246 (75)	328 (100)	410 (125)	492 (150)	656 (200)
50A	0.01 (8)	0.02 (14)	0.03 (22)	0.03 (22)	0.05 (30)	0.06 (38)
100A	0.02 (22)	0.05 (30)	0.06 (38)	0.08 (50)	0.08 (50)	0.09 (60)
150A	0.06 (38)	0.06 (38)	0.08 (50)	0.09 (60)	0.12 (80)	0.16 (100)

Three-Conductor Cable (Unit: in² (mm²))

Length (ft (m)) / Current	164 (50)	246 (75)	328 (100)	410 (125)	492 (150)	656 (200)
50A	0.02 (14)	0.02 (14)	0.03 (22)	0.03 (22)	0.05 (30)	0.06 (38)
100A	0.06 (38)	0.06 (38)	0.06 (38)	0.08 (50)	0.08 (50)	0.09 (60)
150A	0.03x2 (22x2)	0.03x2 (22x2)	0.06x2 (38x2)	0.06x2 (38x2)	0.06x2 (38x2)	0.08x2 (50x2)

Fuel Pipe Selector Valve



WARNING

- Monitor the fuel feeding conditions while feeding fuel from a separate fuel storage tank.
- Do not switch the selector valve to the external tank position unless an external tank is being used. Fuel pipe damage and fuel leakage may result.
- Do not use excessive force operating the selector valve handle. Valve damage and fuel leakage may result.

This valve is designed to feed fuel to the engine from an external fuel storage tank.

Operation

1. Unit is delivered from factory with fuel line piping and selector valves set as shown (A). When operating the unit using installed fuel tank, run the machine with the fuel line piping and selector valves with the factory-arranged settings.
2. When using a separate storage tank (B), remove the plugs (C) fitted at the connections to the separator tank and make piping connections as shown in D. Then switch the selector valve handle as shown (E).
3. When removing the external tank, be sure to return the selector valve handle to the original position (A), remove the external tank piping connections, and reinstall the plugs.

Installation of Separate Storage Fuel Tank and Piping

1. Use oil resistant fuel hose with inside diameter of 8mm to 10mm.
2. Install the fuel tank so that the fuel level of the tank may be kept at a level 0 - 98" (0 - 2.5m) higher than the machine.
3. In order to avoid suction of water and sediment, install the suction and return pipe so that the inlet ports are 0.6 - 0.8" (15 - 20mm) higher than the bottom of the tank (B).
4. When refilling fuel in the tank, be careful to not mix water and sediment.

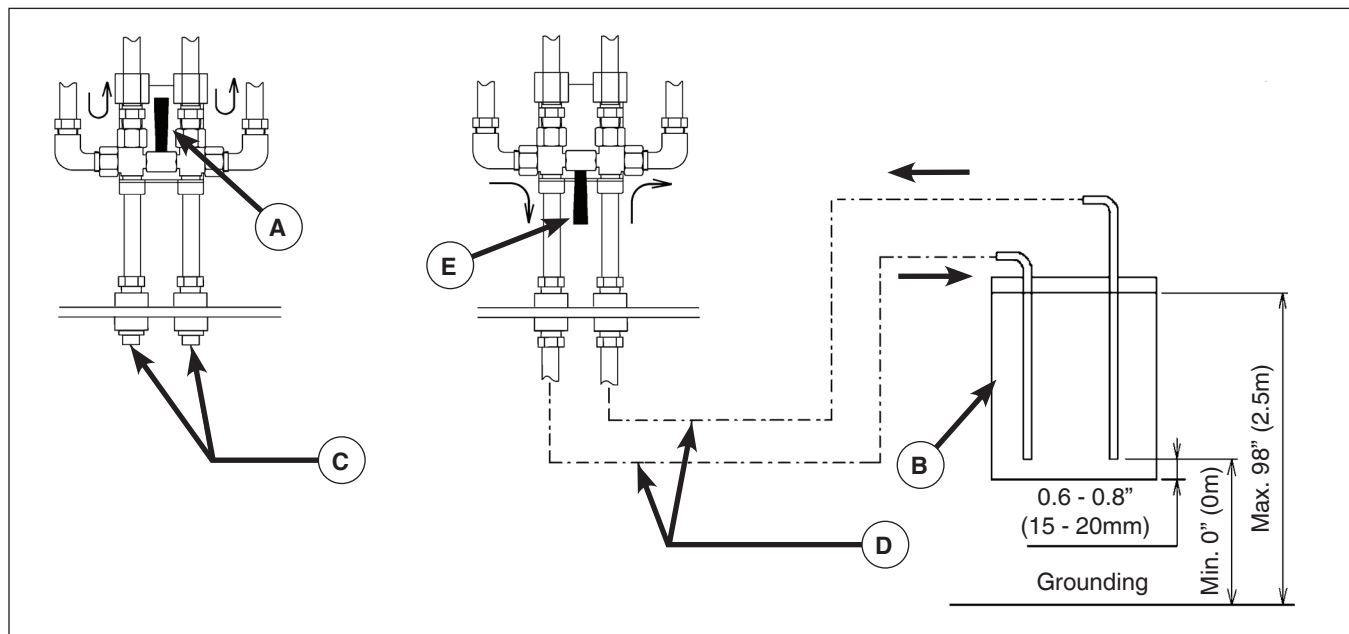

Operation

If you have any problems operating your towable generator, please contact your authorized dealer.

WARNING **POISONOUS GAS**

HAZARD. Engine exhaust contains carbon monoxide, a poisonous gas that could kill you in minutes. You CANNOT smell it, see it, or taste it. Even if you do not smell exhaust fumes, you could still be exposed to carbon monoxide gas.

- Operate this product ONLY outside far away from windows, doors and vents to reduce the risk of carbon monoxide gas from accumulating and potentially being drawn towards occupied spaces.
- Install battery-operated carbon monoxide alarms or plug-in carbon monoxide alarms with battery back-up according to the manufacturer's instructions. Smoke alarms cannot detect carbon monoxide gas.
- DO NOT run this product inside buildings, garages, tunnels, or other partially-enclosed spaces, even if using fans for ventilation. Carbon monoxide can quickly build up in these spaces and can linger for hours, even after this product has shut off.
- ALWAYS place this product downwind and point the engine exhaust away from occupied spaces.

If you start to feel sick, dizzy, or weak while using this product, get to fresh air RIGHT AWAY. See a doctor. You may have carbon monoxide poisoning.

Oil Recommendations

Engine Oil

We recommend the use of CJ-4 class engine oil or superior class for best performance. Using poor quality engine oil may shorten the life of the engine.

Outdoor temperatures determine the proper oil viscosity for the engine.

Use the chart to select the best viscosity for the outdoor temperature range expected.

NOTE: When two or more different brands of oil are mixed, its performance can be deteriorated. When it is expected to be used for a long period at light load (less than 20% load), it's better to replace the oil with suitable oil.

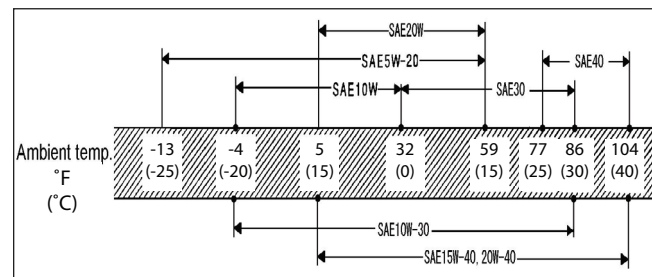

USE OUTDOORS - AVOID CARBON MONOXIDE POISONING



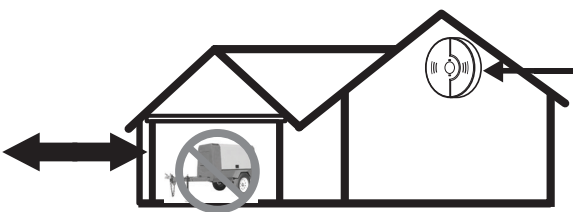

**point away
from home**



CARBON MONOXIDE ALARM(S)

Install carbon monoxide alarms inside your home. Without working carbon monoxide alarms, you will not realize you are getting sick and dying from carbon monoxide poisoning.

Checking / Adding Engine Oil

WARNING   Be sure to check the unit before operation. If any issue is found, be sure to repair it before restarting the unit. Be sure to make daily checks before operation. Operating the unit without prior inspection could result in death or serious injury.

NOTICE Unit should be on level before checking oil level. When you check oil level after initial operation, wait 10 to 20 minutes after stopping engine before checking the oil level.

1. Place unit on a flat, level surface.
2. Clean area around oil fill, remove oil level gauge (A), and wipe it with a clean cloth.
3. Re-insert the oil level gauge fully and pull it out again. The oil level should be between LOW and HIGH (B).
4. If the oil level is below LOW, add engine oil to oil filler port (C).

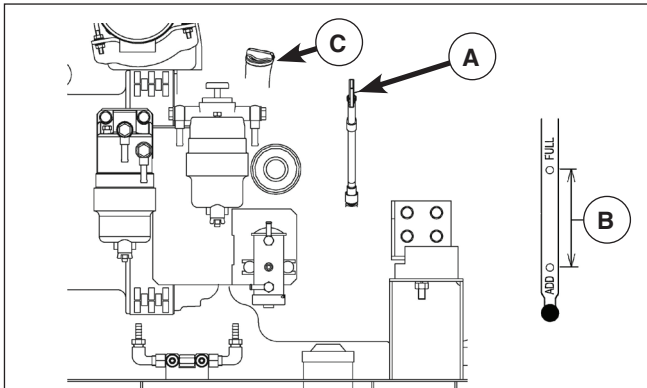

- While checking oil level, check also for contamination. If the oil is found dirty, contaminated or should it be changed according to the periodic inspection list, change the oil. See **Maintenance**.
- Excessive engine oil supply could cause engine output degradation. Therefore, never fill more than the HIGH level.

Checking Coolant Level

WARNING   **Taking off the radiator cap.**

- Be sure to stop the machine and allow time to cool. Then loosen the radiator cap one notch. After the coolant water is sufficiently cooled and the inner pressure is released, take the cap off. If this procedure is neglected, the inner pressure can blow off the cap. Steam jetting out of the radiator could result in serious burns.

NOTICE Continuing operation at low coolant levels could result in damage to the radiator.

1. Check the coolant level in the reserve tank. If it is lower than the limit, open the cap and replenish

the coolant. Level must be kept above LOW mark (D).

2. If there is a little or no coolant in the reserve tank, remove the radiator cap and check the coolant level. Supply coolant to the radiator and also the reserve tank, if necessary. See **Maintenance**.

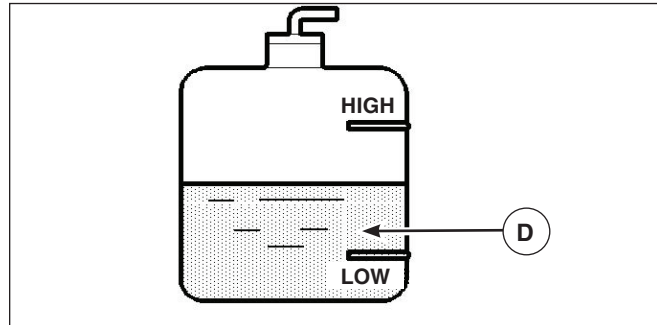

Checking / Adding Fuel

Fuel must meet these requirements:

- Do not use such diesel fuel having higher sulfur content above 0.0015%(15 ppm).
- Use ultra-low sulfur diesel fuel only for diesel engine.
- Use such diesel fuel which conforms to either standard EN590 or ASTM D975.
- Do not use kerosene. And never use fuel mixed with kerosene.
- Carbon residue content in fuel must be a low.
- Follow the designated regulations to dispose of fuel.

NOTICE Fuel for **DIESEL** engines must have the following specific characteristics:

- It must be free from even minute dust particles in it. (Do not use such diesel fuel which has been long stored in a oil drum.)
- It must have optimum viscosity.
- It must have high cetane number.
- It must have high fluidity even at low temperature.
- Carbon residue content in fuel must be a low.
- It must not contain zinc and NA (sodium).

NOTICE Before starting operation, make sure to check the level of residual fuel so that fuel shortage during operation can be avoided. Drain condensate accumulated at the bottom of the fuel tank whenever necessary.

WARNING   **Fire Prevention.**

- Do not allow ignition sources near fuel.
- Fuel is extremely flammable and dangerous. Handle with extreme care.
- Refuel only after stopping engine, and never leave open fuel can near machine. Do not spill. If fuel is spilled, wipe up completely.
- Refilling fuel tank should be done outdoors or in a well-ventilated location.

- Do not fill fuel oil up to the cap level. When fuel tank is filled to cap level, fuel oil will overflow due to volume expansion caused by rise of ambient temperature. Fuel may also spill due to machine movement or transporting.

Checks Before Starting

Check Fuel Filter / Pre-Filter for Condensate

If the red float (B) below the interior element (A) of the fuel filter rises up to water drain level (C), it is necessary to drain water.

1. Clamp both inlet and outlet ends (D) of the fuel hose.
2. Open drain valve (E) to drain accumulated condensed water into an approved container.
3. After draining the condensate, close the drain valve.
4. Dispose of condensate according to local, state and/or federal regulations.

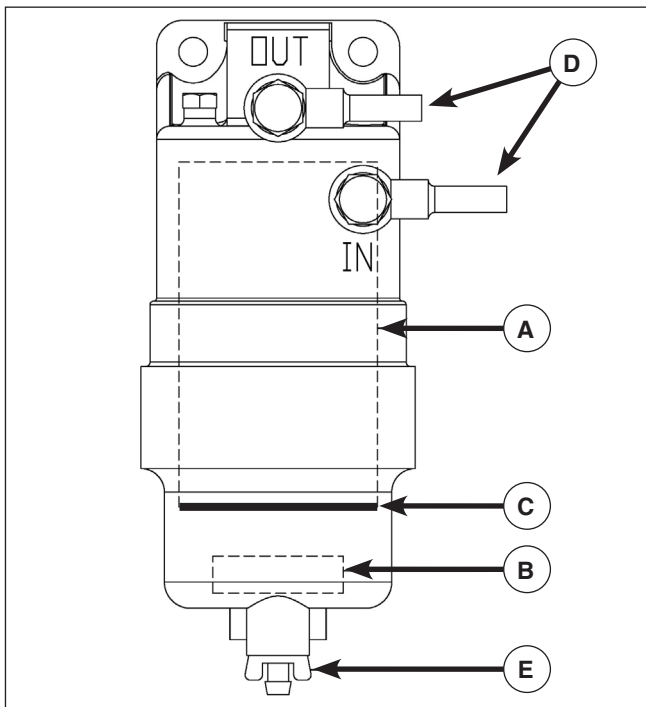

Check Belt Tension

NOTICE If belt tension too tight, it can cause shaft breakage or shorten the life of a bearing. If too loose, the belt may slip and will cause early breakage or damage to the belt.

1. Visually check the belt for any cracks, wear, and other defect. Replace if needed.
2. Depress the middle of the belt with a finger. Belt deflection should be between 0.24 - 0.26" (6 - 7mm) (F).

If adjustment is needed:

1. Loosen the alternator mounting bolt. Adjust until belt deflection is 0.24 - 0.26" (6 - 7mm) when pressing with a finger. Tighten securely.
2. Wipe any grease, oil, coolant, etc. from belt.

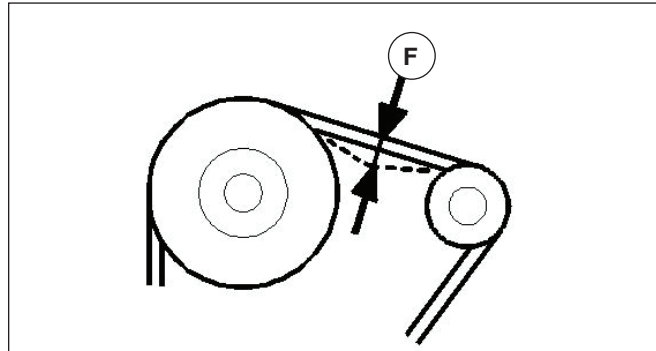

Check Thermo-Label on Stator

The thermo-label on the stator (G) irreversibly changes color from white to brown if reaching or exceeding 212°F (100°C), which indicates generator overload during operation.

If thermo-label has changed color:

- Replace thermo-label. Contact your authorized dealer.
- Reduce load to avoid overloading generator.
- Check components for dust and dirt. Clean as necessary.

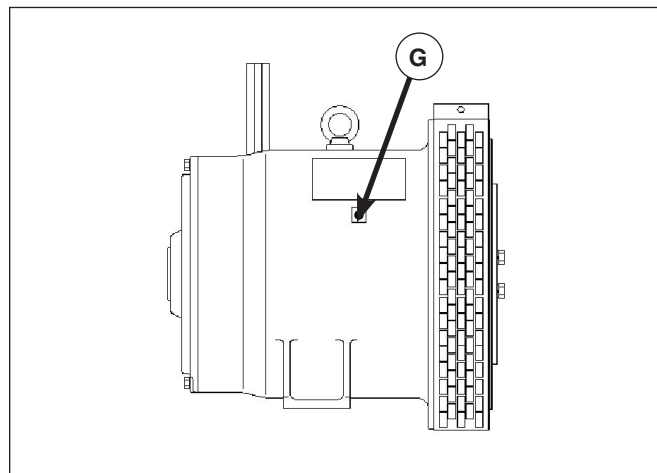

Check Oil Fence for Condensate

1. Remove the drain plug (H) and drain any condensate accumulated inside the oil fence into an approved container.
2. After making sure all condensate is drained, reinstall the drain plug.
3. Dispose of condensate according to local, state and/or federal regulations.

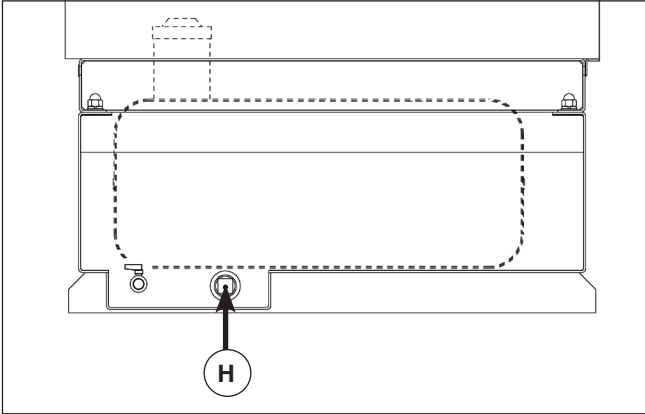

Clean Control Panel

Open control panel and check each breaker, terminal plate and controller for any dust, sand and dirt accumulated. Clean with compressed air.

Unit Operation



- Keep the door shut and locked when machine is in operation.
- If opening the door is necessary, be careful not to touch rotating or hot parts. Burns or serious injury could result.

NOTICE Be sure to let unit warm up after starting for smooth operation of the engine and the generator. Do

not operate the engine at full load immediately after starting. This will shorten the equipment life.

- During machine warm-up, inspect the equipment for any loose parts, fluid leakage, and other issues.
- Make sure that monitor lamps are off.
- Be sure to operate the generator at a rated frequency, irrespective of the load capacity.
- Operating the unit at a frequency lower than the rated frequency could result in generator damage.
- Avoid operating the unit for long periods without loads or with light loads.

To Start Unit

Manual Operation

1. Check and confirm that both the main circuit breaker (A) on the operation panel and the circuit breakers for the auxiliary receptacles at the output terminal panel are in the OFF position.
2. Set the selector switch (B) to MANUAL operation.
3. Turn the starter switch (C) to the RUN position. The engine starts preheating automatically.
4. When the preheating lamp (D) turns off, turn the starter switch to the START position to start the engine.
5. Once engine has started, let it warm up about 5 minutes at no-load condition.
6. After warm-up, check the frequency meter (E). Adjust to the rated frequency by turning the frequency selector switch (F) UP or DOWN.
7. Adjust to the rated voltage by turning the voltage adjuster knob (H) while monitoring the voltmeter (G).
8. Supply power to the load(s) by switching both the main circuit breaker and the circuit breaker(s) for the auxiliary receptacle(s) to the ON position.

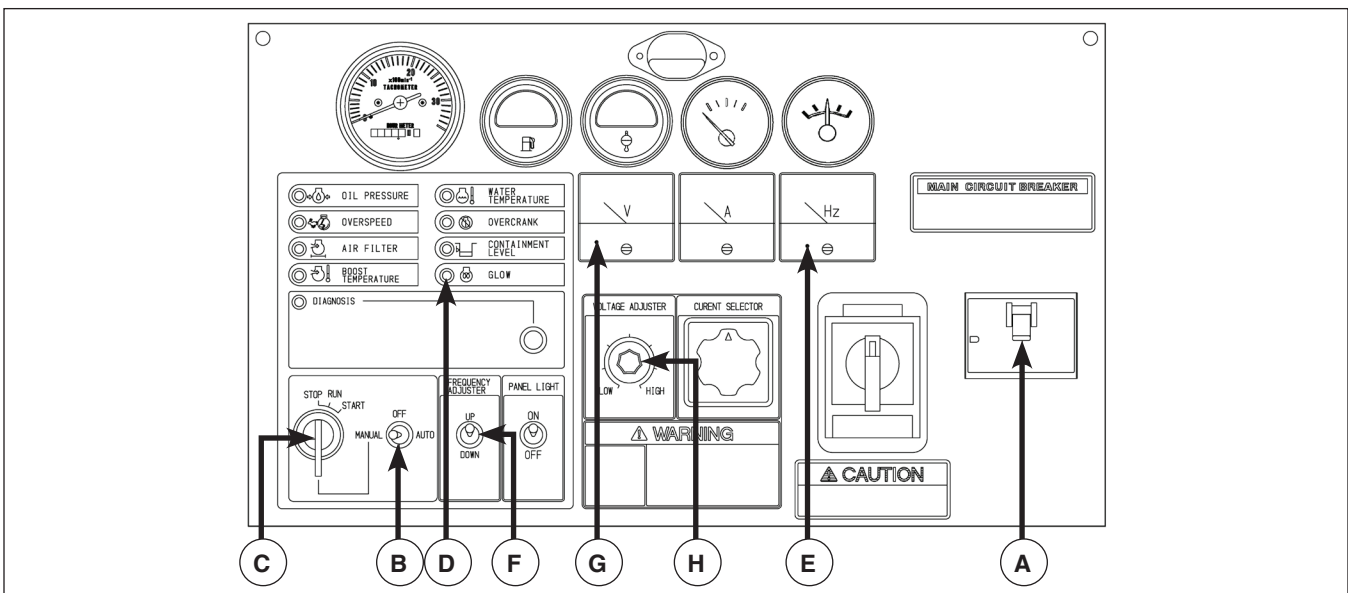

Automatic Operation



- Never put hands close to the interior of the machine, as the generator can start unexpectedly.
- Before starting inspection and maintenance, make sure to place the selector switch to MANUAL operation, and hang a tag stating “Under inspection and maintenance”.
- Remove the black negative (-) cable from the battery.
- Remove the starter key from the unit.
- Failure to heed the above-noted items could result in death or serious injury.

Connection of Remote Control Switch

- The remote control terminal (**A**) is provided inside the output terminal. Perform cable connection as shown below for remote control operation of the machine. Be sure to remove the black negative (-) cable from the battery before making connections.

NOTE: When the unit is in AUTOMATIC mode, battery discharge occurs. Be sure to charge battery.

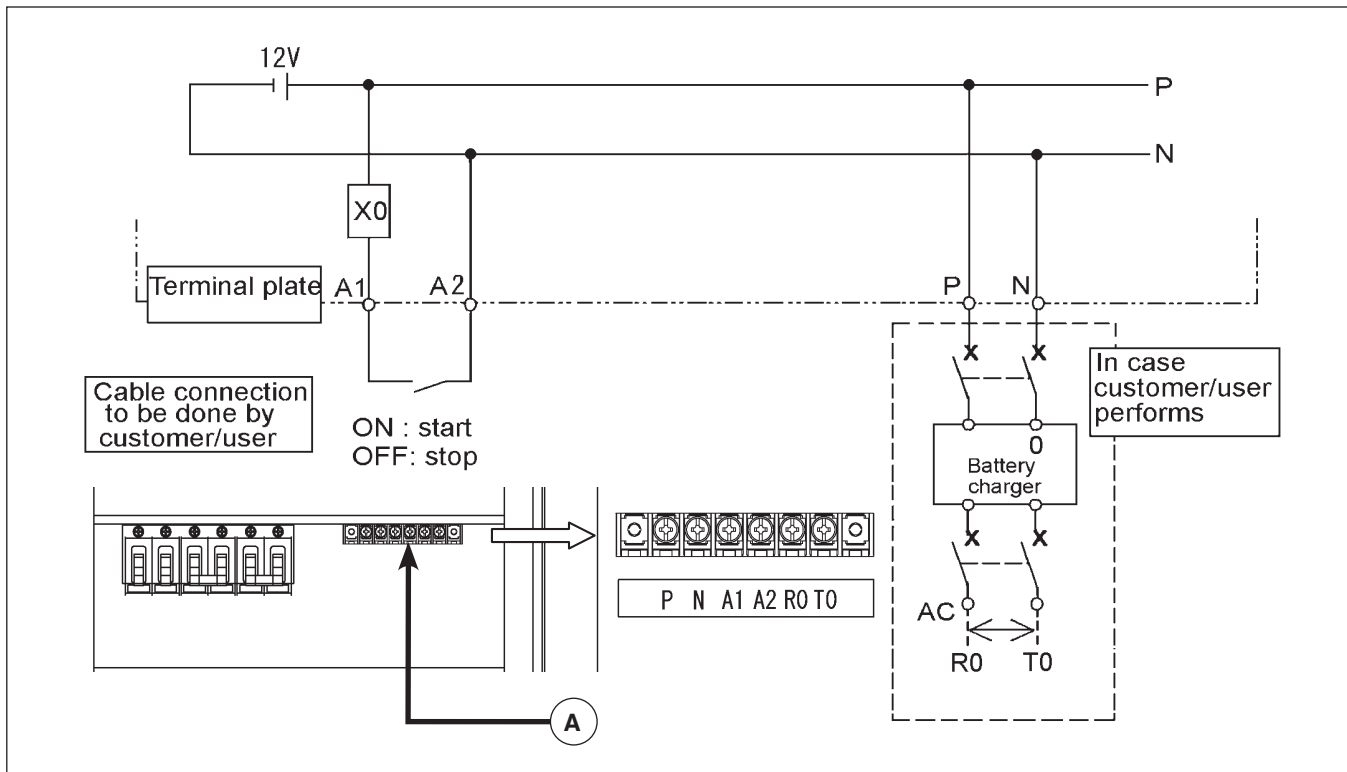

Operating Procedure

1. Start the generator unit and adjust the frequency and voltage as outlined in **Manual Operation**.
2. Turn the starter switch to the STOP position to stop the engine.
3. Turn the main circuit breaker, as well as the circuit breaker of any receptacle connected to a load, to the ON position.
4. Turn the operating selector switch on the control panel to the AUTO position, and turn the engine speed switch to the HIGH position.

5. The unit is now in stand-by mode, and will start once the start signal is sensed. See **Function**.

Function

- When the start signal activates in stand-by mode, it starts the unit. (This includes preheating.)
- When the stop signal activates, the unit continues to operate for 70 seconds for a cool-down phase, then the unit stops and is placed again in stand-by mode.

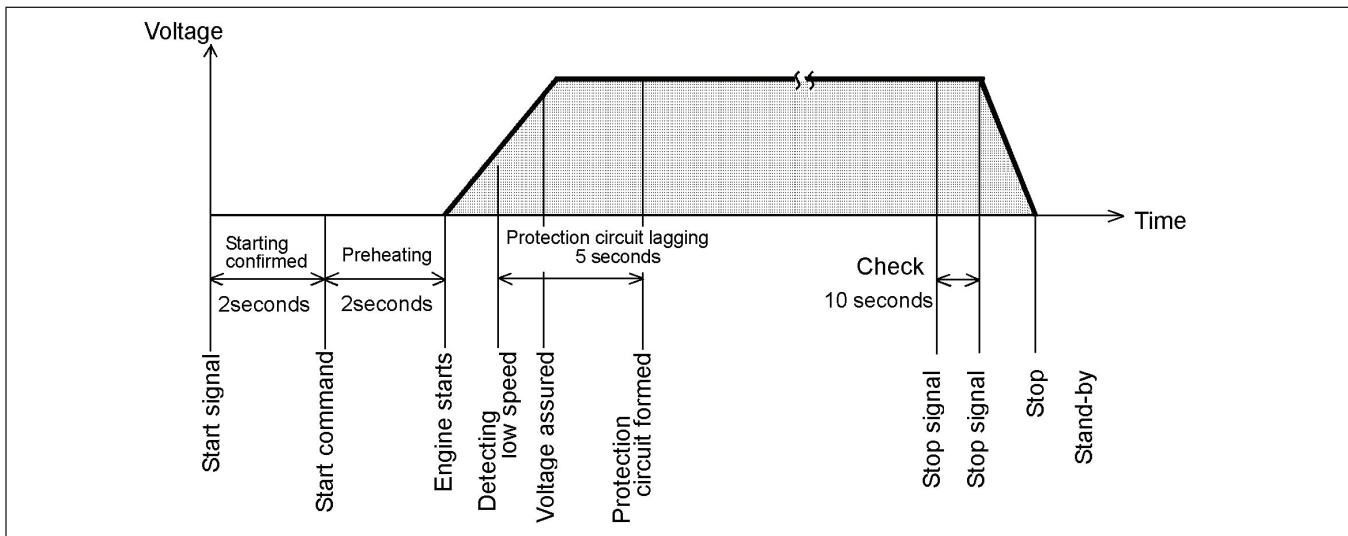

Starting Action

- The unit will attempt to start over three 10-second intervals, with an 8-second break (including preheating) between attempts. If after the third attempt the unit will not start, an indicator light will light, indicating the problem. See **Meters and Indicator Lights during Operation**; see also **Troubleshooting**.
- If the OVERCRANK indicator light turns on, immediately press the emergency stop button. See **Emergency Stop**.

NOTICE Failure to press the emergency stop button when the OVERCRANK indicator light turns on may result in engine damage.

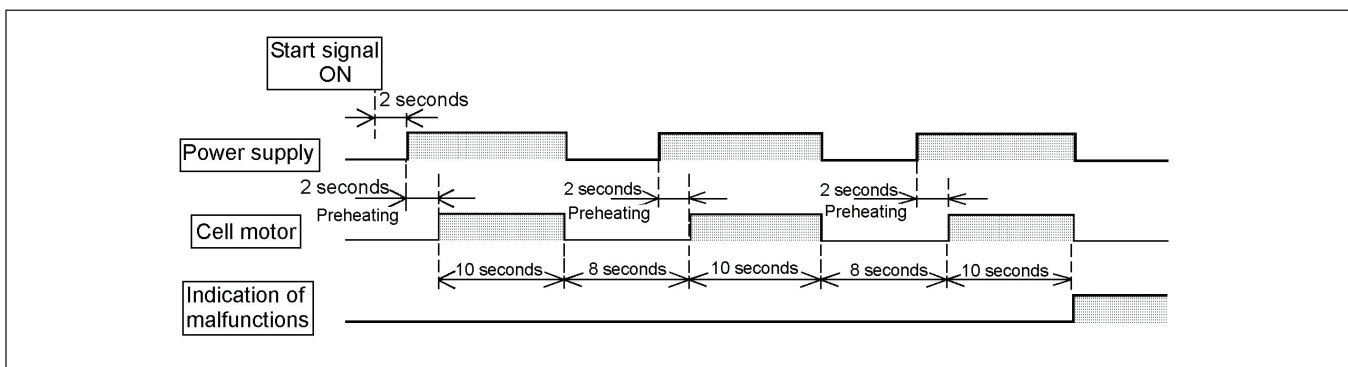

Meters and Indicator Lights during Operation

During normal operation, each indication of instruments is shown in the table below. Refer to the table for daily checks.

NOTE: The values marked * vary with location of the voltage selector switch.

	Voltmeter (V)	Frequency Meter (Hz)	Ammeter (A)	Monitor Lamp								
				Oil Press	Over Speed	Air Filter	Boost Temp	Water Temp	Over Crank	Containment Level	Glow	Diagnosis
Before Starting (RUN)	0	0	0	● Off	● Off	● Off	● Off	● Off	● Off	● Off	● On	● Off
During Operation	* 240 480	60	Less than rated current	● Off								

- Be sure to frequently check meters and indicators for proper operation, or any machine water, oil, fuel leaks, etc.
- The above table gives standard values. They may vary slightly depending on operating conditions and other factors.
- In single-phase load operation, check the current of L1, L2, and L3 phase with the ammeter, by turning the ammeter change-over switch. Each current should be balanced if unbalanced. Change load connections so the current of L1, L2, and L3 is equally balanced. Make sure that the current of each phase does not exceed the rated one.
- When the voltage selector switch is in the single-phase 240/120V position, place the ammeter change-over switch to the L1 or L3 position to read the output.

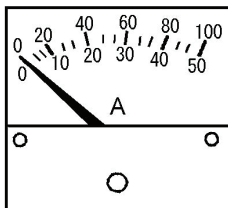

Upper scale: low voltage
For 200 V class

Lower scale: high voltage
For 400 V class

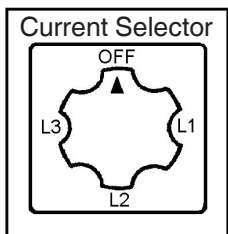

Panel Light

- The instruments are provided with transmission type illuminators. Switch the panel light to ON.
- When illumination is not necessary, turn the light OFF to conserve lamp life.

Stopping the Unit

1. Switch the circuit breakers for the auxiliary receptacles, as well as the main circuit breaker on the operation panel, to the OFF position.
2. Allow the unit to cool down for approximately 5 minutes, then turn the starter switch to the STOP position to stop the engine.
3. While the machine is unused, keep the operation selector switch in the OFF position.

Emergency Stop

NOTICE

- The Emergency Stop button should be used only for emergencies.
 - Regularly check the operating performance.
1. If it is necessary to stop the generator in the event of an emergency, press the Emergency Stop button.

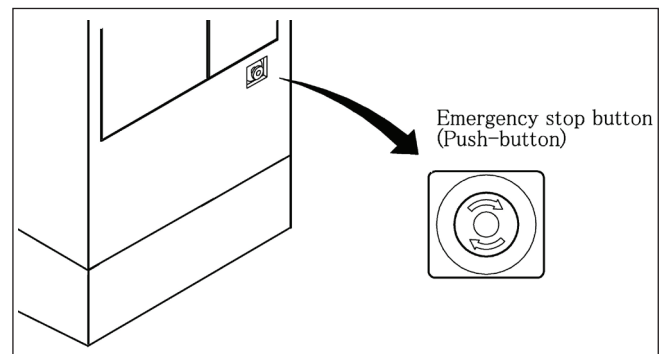

2. To reset the button, turn the button head in the direction of the arrow. If it is not reset, the machine will not restart.

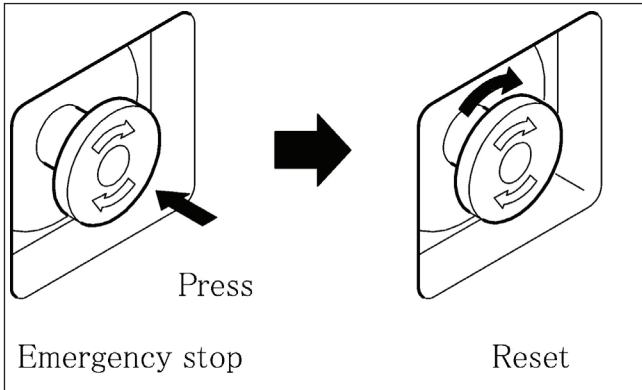

Air Bleeding

If the unit runs out of fuel, the air must be bled from the fuel system once the unit is refueled.

1. Turn the manual-auto selector switch on the control panel to the MANUAL position.
2. Turn the starter switch to the RUN position to keep the electromagnet pump functioning.
3. Loosen the air bleeding plug (**A**) enough to move the priming pump (**B**) until fuel comes out (at least 20 times).
4. Close the air bleeding plug and move the priming pump until fuel is filled in the fuel filter (at least 10 times).
5. After waiting about 1 minute, loosen the air bleeding plug to bleed air from the air filter.
6. Repeat Steps 2 through 4 until air does not come out from the air bleeding plug (at least 3 times).
7. Perform warm-up operation for 3 minutes after the engine starts.
8. When the machine is not in use, the manual-auto selector switch should be turned to OFF.

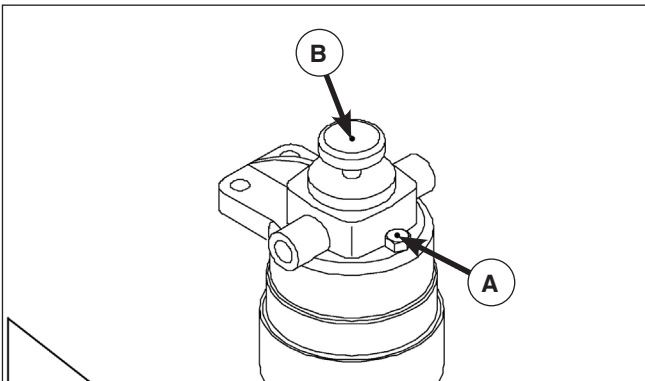









Protection Devices

To prevent possible unit damage during operation, this machine is provided with various protection devices.

If the engine stops due to the function of any of these protection devices, correct the problem before attempting to restart operation.

List of Protection Devices

This machine is equipped with the following protection devices (○) in the table. Make necessary repairs in accordance with the noted item.

Item	Engine stops	Three-phase circuit breaker trips.	Lamp display	Monitor	Functions
Engine oil pressure drop	○	—	○		When engine oil pressure drops, it functions. Operating pressure: lower than 15psi (0.1MPa)
Excessive rotation	○	—	○		When engine rotates excessively, it begins to function. Function rotation: Under operation at 60Hz : 2,070min ⁻¹ (69Hz)
Clogging of air filter	—	—	○		When air filter is clogged and it becomes necessary to clean it, it functions.
Boost temperature rises	—	—	○		When boost temperature rises higher than 85°C, monitor lamp goes on.
Water temperature rises.	○	—	○		In case of abnormal rise of engine water temperature, it functions. temperature reaches 100°C
Over crank	○	—	○		This lamp goes on when operator fails to start engine, during automatic operation mode.
* Oil Fence	—	—	○		When more condensate (fuel, engine oil and coolant) than 1/3 of capacity in the oil fence is accumulated monitor lamp lights.
Glow	—	—	○		When starter switch is "ON", the Monitor lamp glows and goes off after preheating is performed.
Overcurrent or short circuit	—	○	—	—	In case of overload or short circuit accident, it functions.
Engine troubles	—	—	○	—	Refer to Troubleshooting

* When the monitor lamp lights in the oil fence, immediately drain it.
(For the capacity of the oil fence, refer to Specifications.) To protect environment, do not drain it directly

Circuit Breaker

In case overload or short-circuited wire connection should occur, the circuit-breaker trips.

If tripped, stop the unit, disconnect the load, reset the circuit breaker, and identify and correct the problem.

To reset the breaker:

Press down on the breaker lever until it clicks.

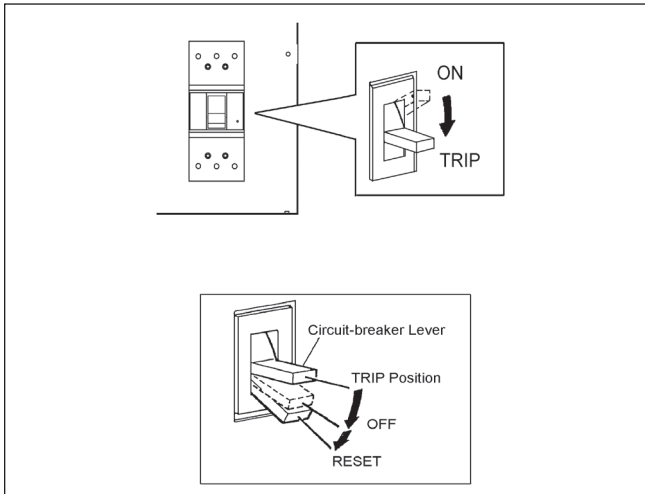

Thermal Relay

In case an overload or short-circuit should occur to the load or load connection cable, this relay functions to trip the circuit-breaker.

It is not necessary to push the reset button even after the three-phase main breaker is tripped since the thermal relay is set to automatic return at the factory.

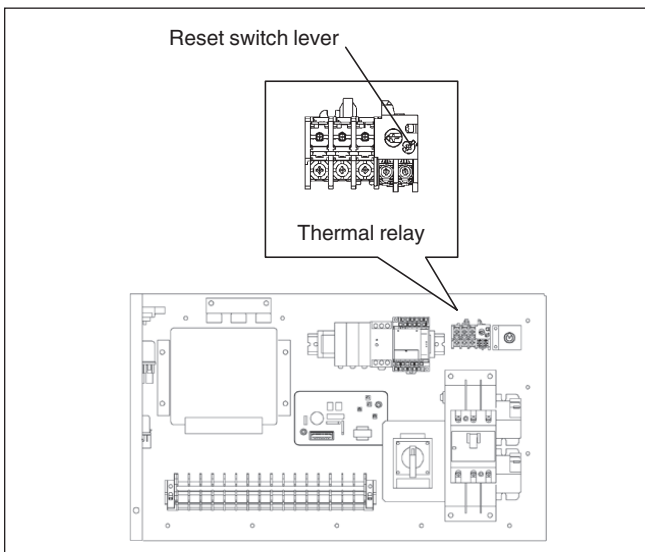

Circuit Protector (CP) for AVR Protection

AVR is equipped with circuit-protector (CP) for protection against overcurrent. It functions in the following cases:

- The machine gets overloaded while engine speed is still lower.
- The output voltage of generator is increased higher than the specified voltage.

When CP functions, voltage drops.

To reset, press the CP (AVR) button (A) which is provided at the side of the breaker plate in the control panel.

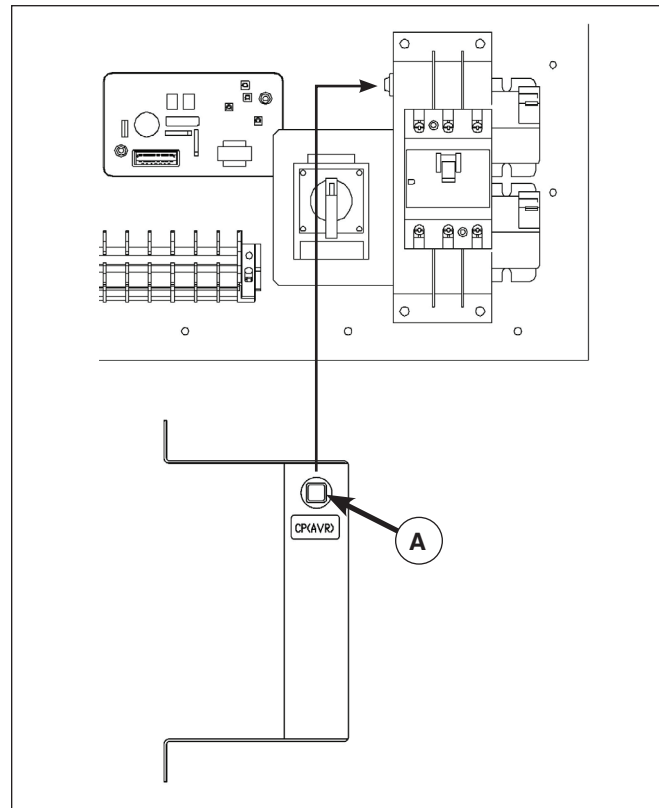

Connecting Loads



WARNING

- Make sure not to connect the output terminal of the machine with a commercial power source. It could result in electric shock or fire.
- Make sure to ground the machine and the load. It could cause an electric shock when the machine is installed at a damp place or on a steel frame or a steel plate.
- Never touch the output terminals during operation.
- Notice that the voltage of several hundred volts is applied to the output terminal.
- When removing or connecting a connecting cable for changing load, be sure to switch OFF the circuit breaker, remove the starter key from the starter switch, then carry out the work. The operator must keep the key during operation.
- For a connecting cable to load, do not use a cable with damaged sheath nor an inappropriate insulation cable to the voltage.

Be sure connections between each cable terminal and input/output terminal are secure. Otherwise, it may be slacked during operation and may cause a fire or an electric shock.

NOTICE

- When using a single-phase load [277V or 139V], see to it that the loads on the different phases will be evenly balanced. Unbalanced loads may cause the generator to overload.
1. Select a cable with sufficient diameter by considering the load capacity and the distance from the generator to the load. Use terminals for connection and securely fasten them.
 2. After checking phase number and voltage of the load, make sure to connect them correctly.

Terminal size (A)

	MP25	MP45
Three-phase output (L1,L2,L3,N)	M8	M14
Leakage relay ground Terminal(G)	M8	M14

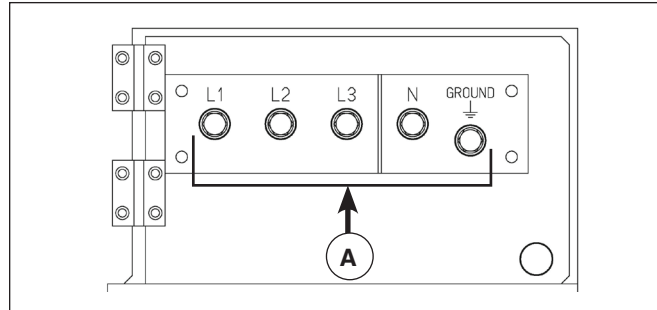

3. Install a switch panel (B) between the output terminal and the load to switch on/off the load. Do not switch the load on/off directly by the circuit-breaker of the generator. It could cause damage to the circuit-breaker.
4. Connect the connecting cable to the load so that the output terminals do not touch each other.

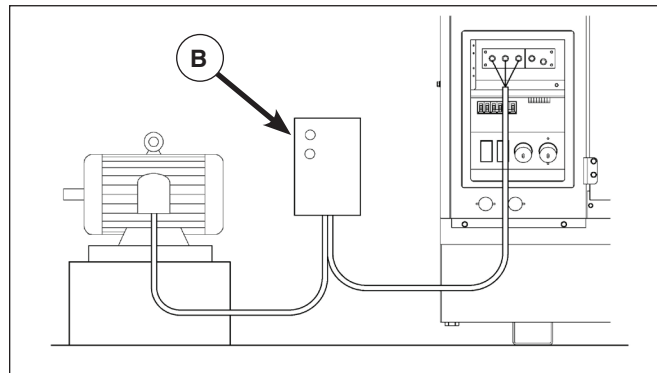

Proper Connection of Three-Phase Four-Wire Type Terminals

- During operation, do not operate voltage selector switch. Voltage selection during operation may cause abnormal voltage on the load side to damage the load and may cause a fire.
- In addition it could cause damage to generator and automatic voltage regulator (AVR).
- Be sure to shut off generator before using voltage selector switch.
- When voltage selection is completed, lock the voltage selector switch in position to prevent anyone from operating it.

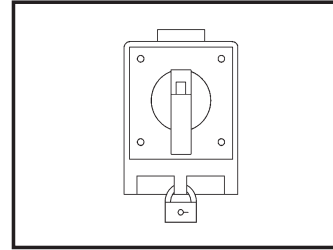

Voltage selector sw.
Three-phase 480/277V

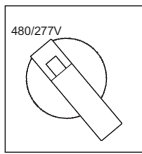

Output terminals
Three-phase 480V

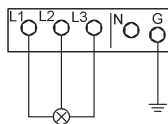

Output terminals
Single-phase 480V

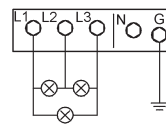

Output terminals
Single-phase 277V

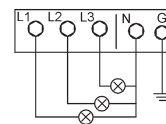

Voltage selector sw.
Three-phase 240/139V

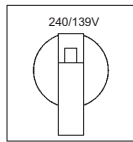

Output terminals
Three-phase 240V

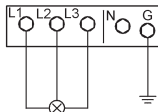

Output terminals
Single-phase 240V

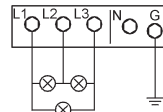

Output terminals
Single-phase 139V

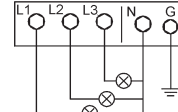

Voltage selector sw.
Single-phase 240/120V

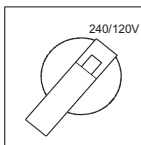

Output terminals
Single-phase 240V

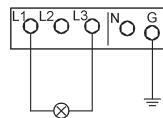

Output terminals
Single-phase 120V

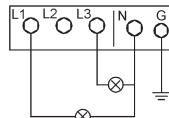

NOTE: When the voltage selector switch is in the single-phase 240/120V position, place the ammeter change-over switch to the L1 or L3 position to read the output.

Auxiliary AC Power

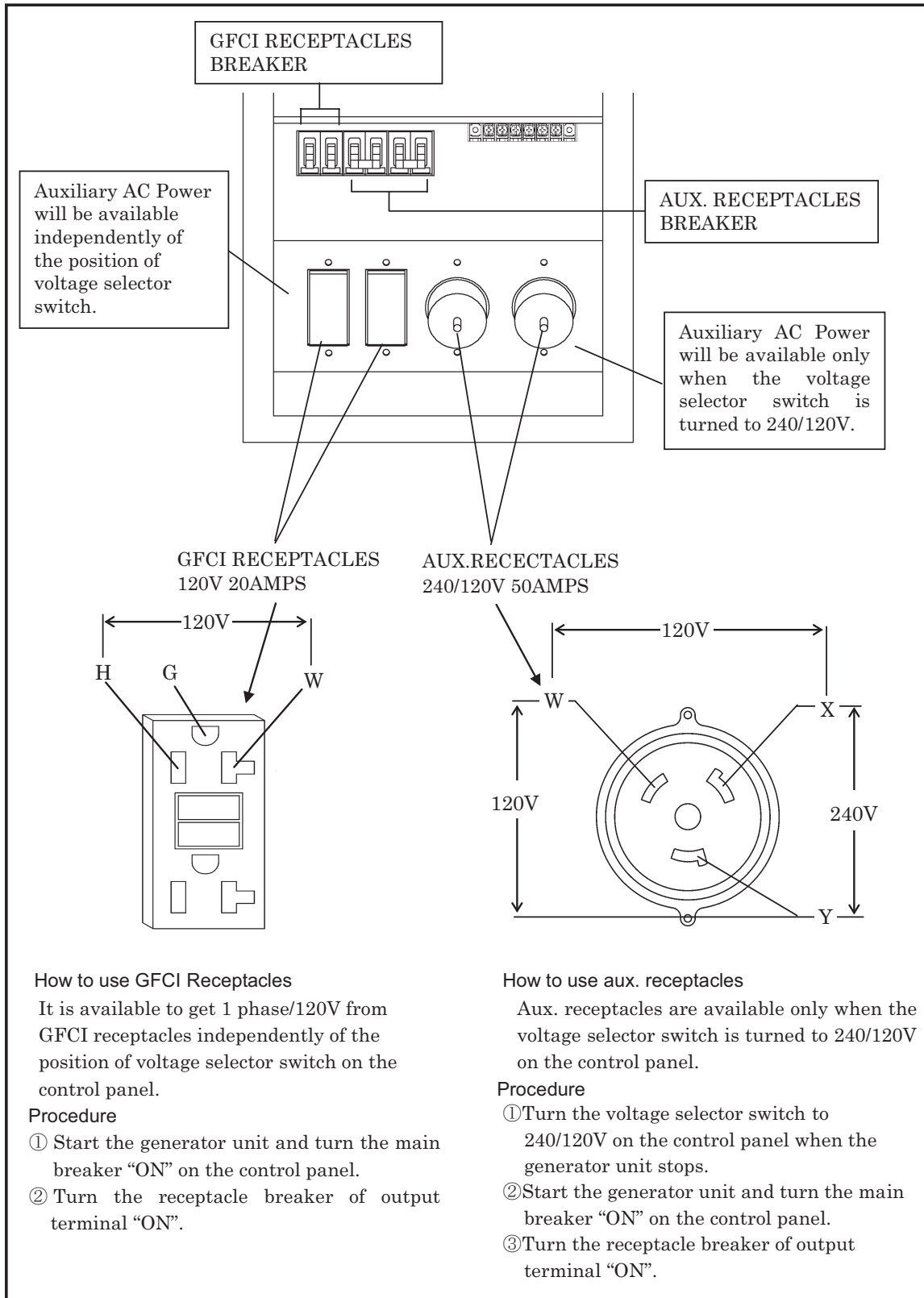

Maximum Combined Simultaneous Power Consumption

NOTICE

- Never exceed the maximum combined simultaneous power consumption.

The following chart shows the maximum power available from the 120V-20A GFCI receptacles during simultaneous consumption (main terminals and receptacles) for both single or three phase settings. Values shown in the left column give the maximum current available at the 120V-20A GFCI receptacles compared to the value of the simultaneous current consumption from the main terminals.

Single Phase 120V-20A GFCI Rcept.	MP25		MP45	
	Three Phase 240/480V	Single Phase 240/120V	Three Phase 240/480V	Single Phase 240/120V
kW	kVA	kVA	kVA	kVA
0.0	25.0	14.4	45.0	26.0
1.2	20.8	13.2	40.9	24.8
2.4	16.7	12.0	36.7	23.6
3.6	12.5	10.8	32.6	22.4
4.8	8.4	9.6	28.4	21.2

Maintenance

Regular maintenance will improve the performance and extend the life of the generator. See your authorized dealer for service.

Generator Maintenance Schedule

Follow the hourly or calendar intervals, whichever occurs first. More frequent service is required when operating in adverse conditions noted below.

Daily
• Check thermo-label on stator
• Clean instruments in control panel ¹
• Check looseness in pipe connecting part, and wear and tear of pipe
• Check each instrument and warning lamp
• Check functions of all instruments and devices
Every 250 Hours
• Check GFCI receptacles ²
• Check insulation resistance ⁴
• Check thermal relay ³
• Check thermo-label on rotor bearing ³

¹ Or whenever needed

² Or monthly

³ Or every 2 months

⁴ Or every 4 months

Engine Maintenance Schedule

Refer to engine operation manual for inspection and maintenance of engine.

Miscellaneous Maintenance Schedule

Daily
• Check condensate in oil fence
Every 500 Hours
• Check electrical terminals and cable connections ¹
Every 1000 Hours
• Check vibration isolator rubbers ²
• Check each rubber hose ²

¹ Or every 4 months

² Or yearly

Undercarriage Maintenance Schedule

Every 300 Hours or 3 Months
• Supply grease to trailer hub bearing
• Check drawbar hardware for proper tightness
Every 1,000 Hours
• Check undercarriage bracket hardware for proper tightness
• Check wheel lug nuts for proper tightness

Replacement Parts

Note: Part numbers may change without notice.
Contact your authorized dealer.

Part Name	Part Number		Qty
	MP25	MP45	
Air Filter Element	32143 11700	---	1
Engine Oil Filter	Isuzu 894456-7412	Isuzu 898075-6761	1
Fuel Filter Element	Isuzu 898240-2800	---	1
Fuel Pre-Filter Element	Isuzu 898240-2790	---	1
Engine Supply Pump Strainer	Isuzu 898074-9550	---	1
Engine Supply Pump Strainer Gasket 'G'	Isuzu 109630-0830	---	3
Engine Supply Pump Strainer Gasket 'H'	Isuzu 109630-0850	---	3
Fuel Air-Bleeding Pump Filter Gasket 'K'	Isuzu 898071-4040	---	1
Belt	Isuzu 898095-3350	---	1

Maintenance Items

Change Engine Oil



WARNING

Engine oil is very hot and highly pressurized during or just after operation. Hot oil could blow out of the tank and can cause serious injury.

NOTICE

Never supply more engine oil than specified level. Excessive engine oil could cause engine damage.

1. After stopping engine, wait 10 to 20 minutes until engine oil cools off.
2. Remove drain plug (A), open drain valve (B), and discharge engine oil drain. Dispose of used oil according to local, state and/or federal regulations.
3. When oil is completely drained, close drain valve and replace drain plug.
4. Remove engine oil filler cap (C), and fill engine with oil. See **Checking / Adding Engine Oil** in **Operation**. (Oil capacity: approx. 2.6 gal.(10.0L))
5. Check oil level: Remove dipstick (D), wipe clean, replace, then remove. Oil level should read between marks on lower end of dipstick (E). Add as needed.

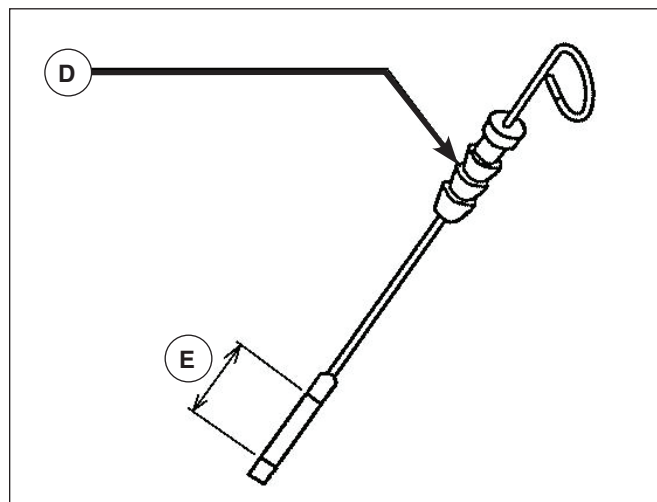
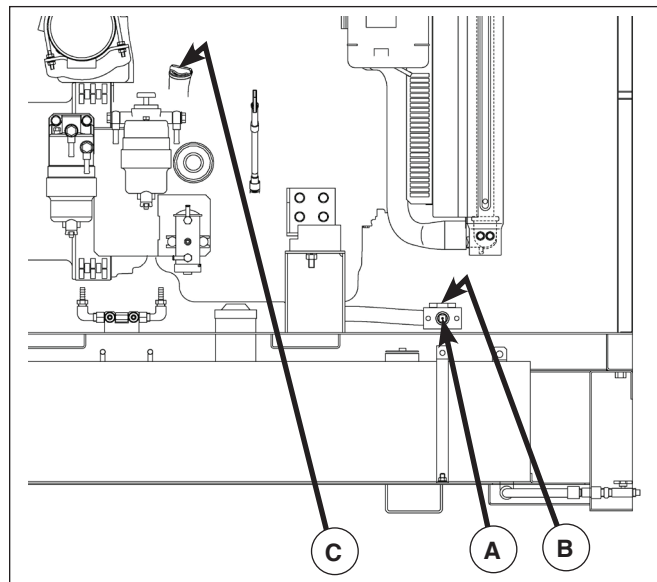

Change Engine Oil Filter

(For part number, see Replacement Parts)

1. Remove old oil filter (A) using a filter wrench.
2. Apply a light coating of oil on oil filter seal (B).
3. Install new oil filter until seal contacts oil pump, then tighten 1 additional turn by hand.
4. After installing oil filter, check for leaks. Tighten as necessary.

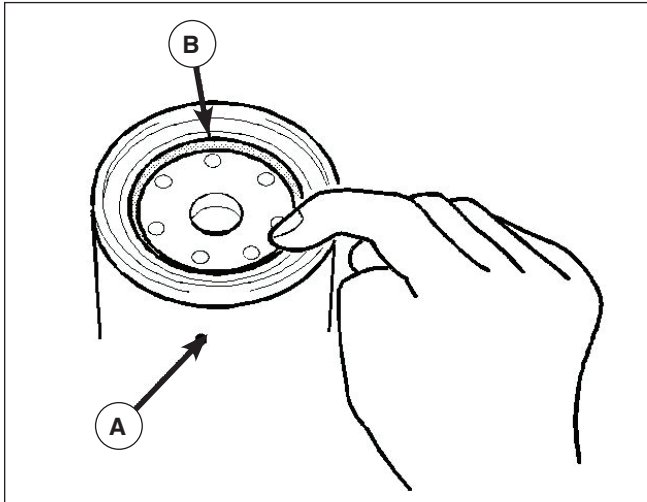

Check GFCI Receptacles

WARNING

- Test the GFCI receptacle before each use.
- In case the GFCI has tripped due to the hazard of ground fault currents, investigate the cause and correct it.

Regularly check GFCI operation for safety.

1. Unplug all appliances from the generator.
2. Start the engine.
3. Turn each single-phase and three-phase breaker ON.
4. Press the TEST BUTTON (C):
 - The RESET BUTTON (D) should extend with a click.
 - If the RESET BUTTON does not extend, contact your authorized dealer.
5. Press the RESET BUTTON.
6. If the RESET BUTTON extends during operation:
 - Unplug all appliances from the GFCI protected receptacle.
 - Press the RESET BUTTON:

IF THE GFCI CANNOT BE RESET:

- The GFCI is faulty. Contact your nearest dealer.

IF THE GFCI RESETS PROPERLY:

- Check the appliance or the power cord.

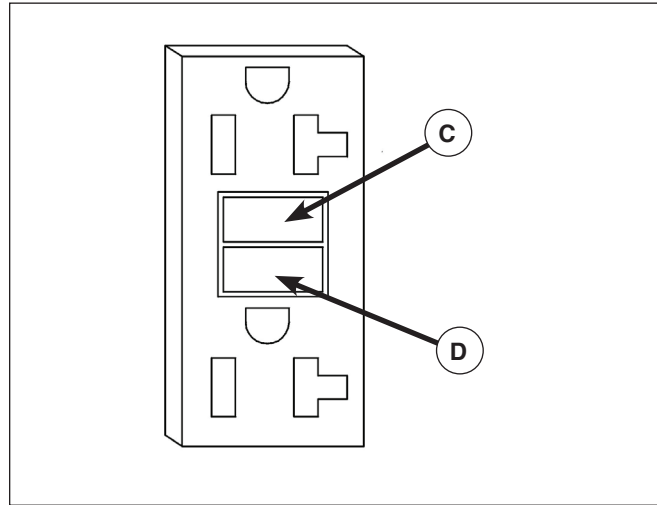

Check Insulation Resistance

WARNING

- Insulation resistance should be regularly checked or measured with a 500V insulation resistance meter. If it is reduced to lower than 1M Ω , it could cause an electrical leakage or a fire.

1. Remove the load side cable from the output terminal board.
2. Remove the grounding terminal from output terminal plate "N" and "GROUND", out of the grounding position of the unit.
3. Loosen the ground terminal mounting bolts of the unit (E), and remove the ground terminals (F).
4. Remove the AVR connector (G) inside the generator control panel.
5. Switch ON the three-phase breaker (H), measure each insulation resistance between the terminals L1. L2. L3 terminal and bonnet (I).
6. If insulation resistance value measured is found more than 1M Ω , it is good. If lower, contact your authorized dealer.

NOTE: For improvement of insulation resistance, wipe and clean dust and dirt from around output terminals, circuit breaker, generator body outlet port and receptacles.

7. After checking and confirming that insulation resistance is proper, reestablish all connections.

WARNING

- Be sure to reconnect the cable between the terminal "N" and terminal "Ground" just as it was originally connected. If left disconnected, the lack of grounding could result in electric shock.

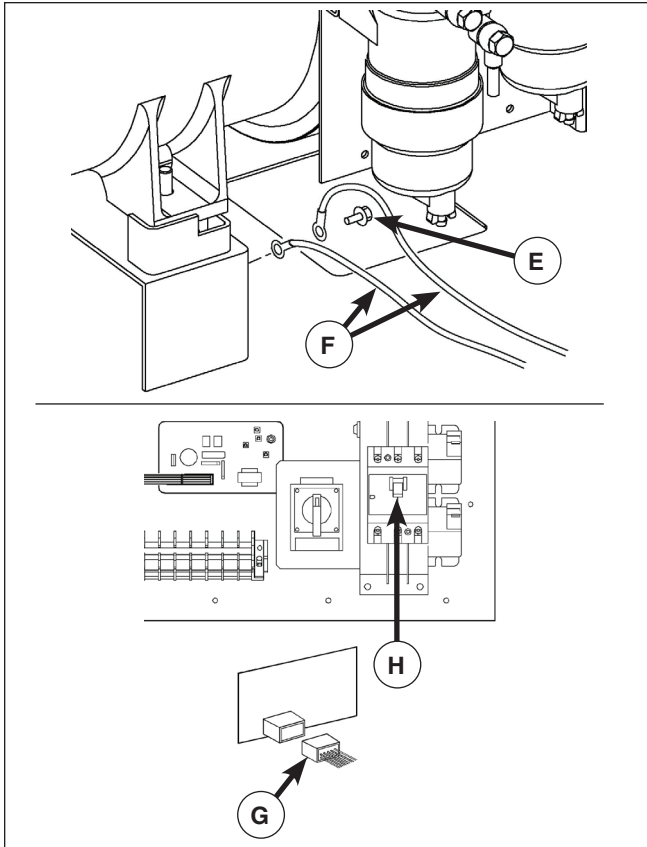

Check / Clean Air Filter Element

1. Loosen latch (K), and remove cap (J). Clean interior of cap. Be sure O-ring (M) is properly seated in cap.
2. Remove and clean filter element (L). If damaged or heavily soiled, replace. (For part numbers, see **Replacement Parts.**)
3. Clean interior of case (N).
4. Install filter element into case, then install cap, securing with latch.

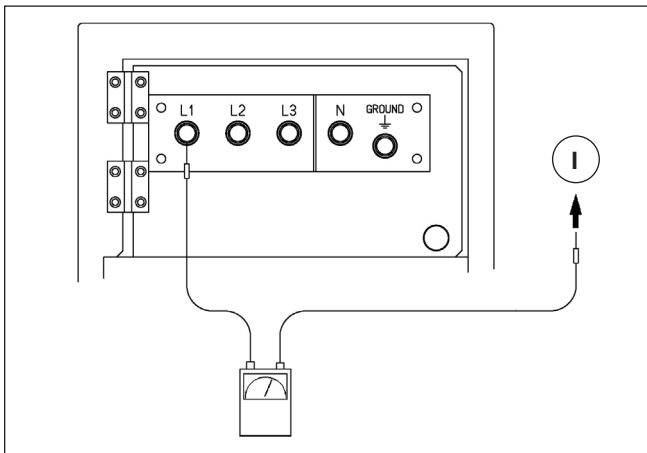
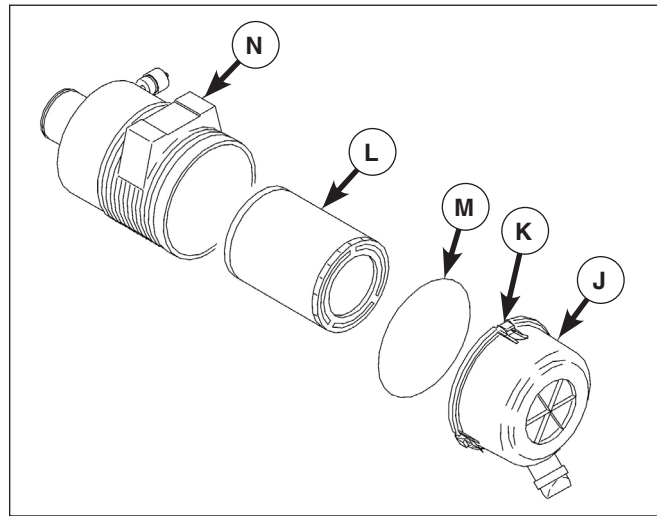

Drain Fuel Tank

1. Remove the drain plug (O) and drain any condensate accumulated inside the fuel tank (P) into an approved container.
2. After making sure all condensate is drained, reinstall the drain plug.
3. Dispose of condensate according to local, state and/or federal regulations.

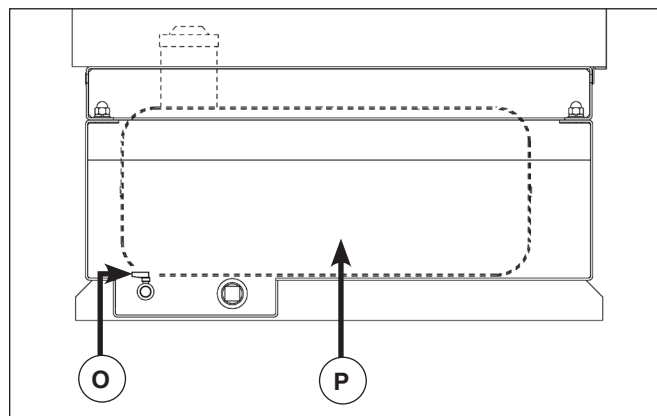

Battery Maintenance



WARNING

- Keep ignition sources away from battery.
- Battery generates hydrogen gas and may explode if ignited.
- Charging should be done at a well-ventilated place.
- Do not spark near the battery nor light a match, nor bring lit cigarette and match close to the battery.
- Do not check the battery by short-circuiting the positive and negative terminals.
- Do not operate machine or charge battery with low electrolyte level. Doing so may damage battery, or may cause explosion.
- Add distilled water so that electrolyte level reads between “UPPER” and “LOWER” level.
- Do not charge frozen battery. Otherwise it may explode. If battery is frozen, warm it up until the battery temperature becomes 16°C to 30°C.
- Battery electrolyte is dilute sulfuric acid.
- Mishandling battery could cause severe burns.
- Wear protective gloves and safety goggles when handling battery.
- If battery electrolyte contacts clothes or skin, wash immediately with large amount of water.
- If battery electrolyte gets into eyes, flush with plenty of water and seek immediate medical attention.
- Dispose of battery according to local, state and/or federal regulations.

Check Battery Electrolyte

Standard battery:

1. Check battery electrolyte level. If low, add distilled water.
2. Measure specific gravity of battery electrolyte. If below 1.24, recharge battery. See **Charge Battery**.

Maintenance-free battery:

1. Check indicator on top surface of battery.
2. If indicator shows that charge is needed, recharge battery.

Charge Battery

1. Disconnect cables between battery and unit, black negative (-) cable first, and charge battery (A) with a 12-volt battery charger (B). Do not charge two batteries at the same time.
2. Be sure not to connect (+) and (-) terminals backwards.
3. Read operation manual of battery charger before use.

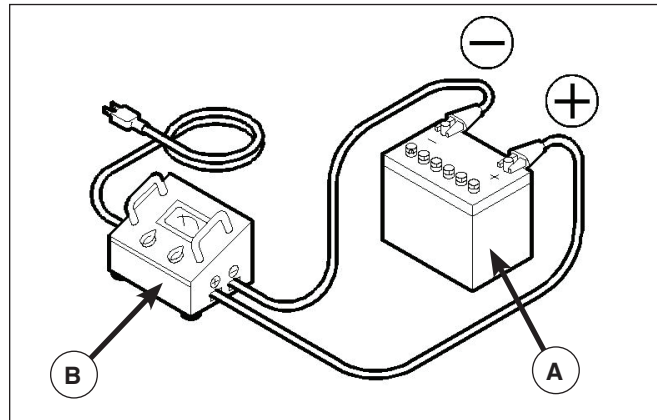

Booster Cables

To use booster cables:

1. Connect one end of red positive (+) cable (C) to positive (+) terminal of machine battery (D).
2. Connect other end of red positive (+) cable to positive (+) terminal of external battery (E).
3. Connect one end of black negative (-) cable (F) to negative (-) terminal of external battery.
4. Connect other end of black negative (-) cable to engine block of machine (G, not shown).



CAUTION

- Be careful not to connect positive (+) and negative (-) terminals backwards.
5. Start engine.
 6. Disconnect booster cables by following above procedure in reverse order.

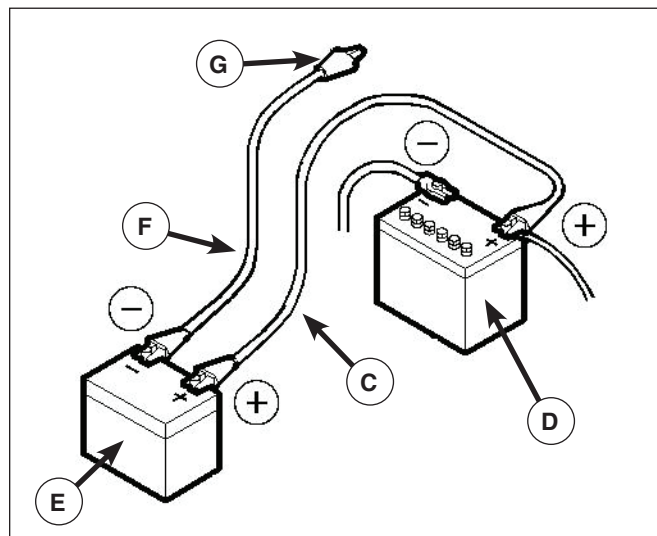

Check Thermal Relay

1. Turn the starter switch to the ON position.
2. Set the main circuit breaker to the ON position.
3. The three phase main breaker will trip if you push the test lever (A) of the thermal relay.
4. Note that once the three phase main breaker trips to the off position, the single phase breaker that supplies power to the GFCI outlets can still be ON.

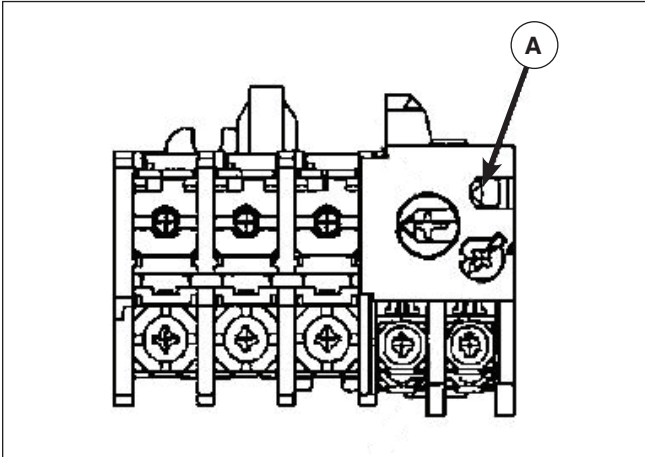

Check Thermo-Label on Stator

The thermo-label on the rotor bearing (B) irreversibly changes color from white to blue if reaching or exceeding 176°F (80°C).

If thermo-label has changed color:

- Replace thermo-label. Contact your authorized dealer.
- Check bearing for noise.
- Check components for dust and dirt. Clean as necessary.

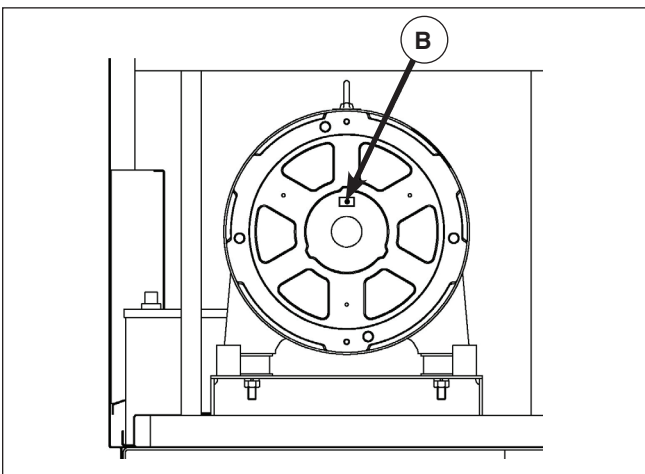

Change Fuel Filter Element

For element part number, see **Replacement Parts**.

1. Drain the fuel out of the inside of fuel filter by loosening the drain valve (C) and air bleeding plug (D). After drainage is completed, retighten the drain valve and air bleeding plug securely.
2. Remove the element case (E) by using a filter wrench.
3. Place a new element (F) in the element case and screw it after coating the O-ring (G) thinly with fuel.
4. After the O-ring contacts the seal surface, retighten it by using a filter wrench.
5. Perform air bleeding out of the fuel. See **Operation**.
 - When changing element, replace O-ring at the same time.
 - After installing the element, check and confirm that there is no fuel leak during operation.
 - For the details of replacement of element, refer to the engine instruction manual.

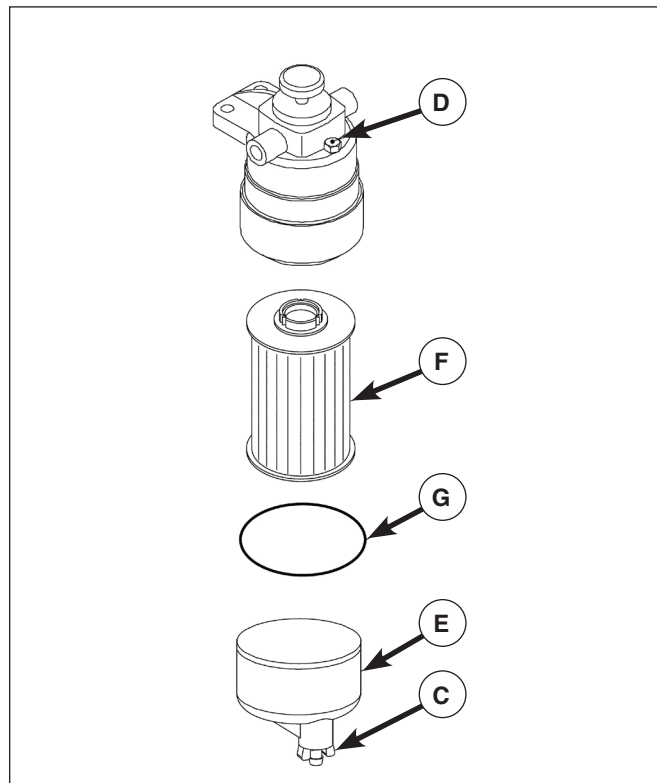

Change Fuel Pre-Filter Element

For element part number, see **Replacement Parts**.

1. Drain the fuel out of the inside of fuel filter by loosening the drain valve (A) and air bleeding plug (B). After drainage is completed, retighten the drain valve and air bleeding plug securely.
 2. Remove the element case (C) by using a filter wrench.
 3. Place a new element (D) in the element case and screw it after coating the O-ring (E) thinly with fuel.
 4. After the O-ring contacts the seal surface, retighten it by using a filter wrench.
 5. Perform air bleeding out of the fuel. See **Operation**.
- When changing element, replace O-ring at the same time.
 - After installing the element, check and confirm that there is no fuel leak during operation.
 - For the details of replacement of element, refer to the engine instruction manual.

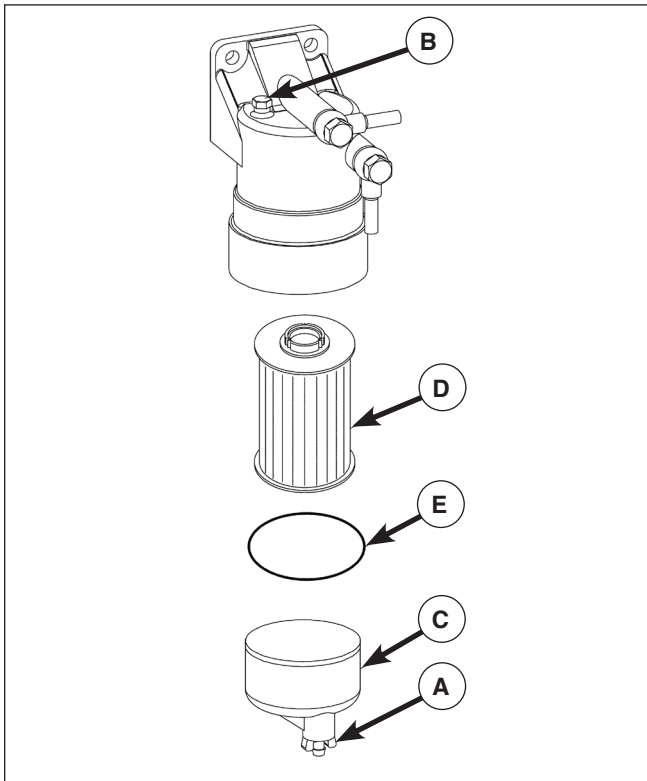

Check / Clean Supply Pump Strainer

For part numbers, see **Replacement Parts**.

1. Loosen the supply pump strainer (F, joint bolt built-in type) and remove it. Then after washing it in diesel oil, blow dust and dirt off with high pressure air. Replace gaskets (G and H).
- If engine performance does not improve after cleaning, replace strainer.

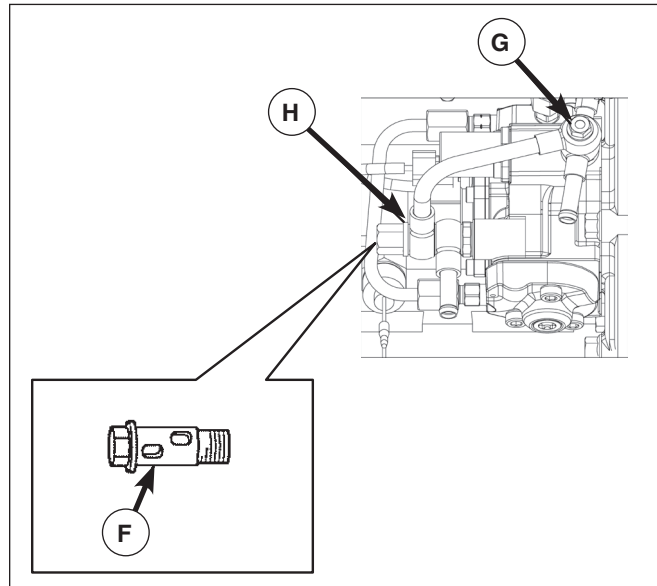

Clean Fuel Air-Bleeding Electromagnetic Pump Filter

For part numbers, see **Replacement Parts**.

1. Turn the cap (I) to the left and remove.
NOTE: Collect any fuel that spills in an approved container.
2. Remove and clean the filter (J). Replace if needed.
3. Replace the gaskets (K).
4. Install filter with gaskets, securing with cap.

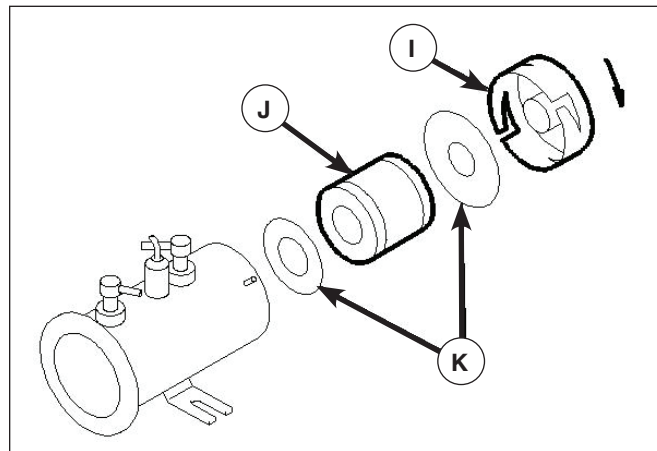

Clean Outside Of Radiator / Intercooler (MP45)

- Clean the fin tubes (C) of the radiator (A) and intercooler (B, MP45 only) of dust or other foreign materials.

NOTICE

Do not use high pressure cleaning equipment, as it may damage fin tubes.

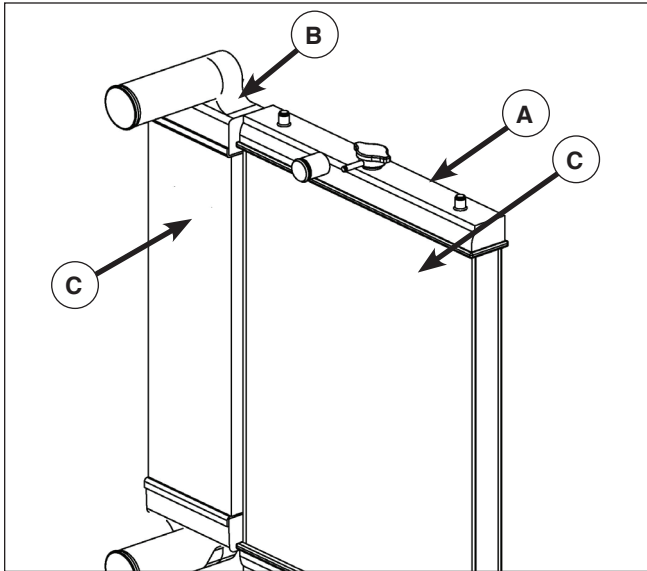

Drain Intercooler (MP45)

1. Remove the drain plug (D) below the intercooler to drain condensate.
2. After draining is complete, reinstall the drain plug.

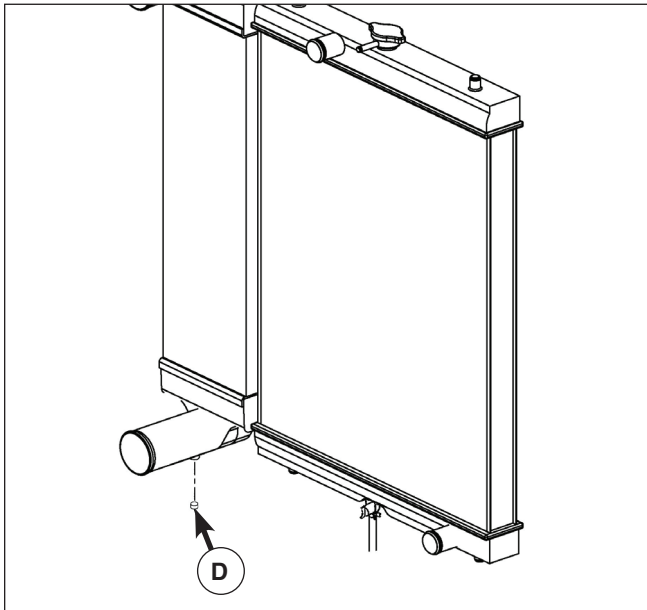

Check Exhaust Flexible Pipe

1. Check for any cracks or leaks on the flexible exhaust pipe (E).
2. If any cracks or leaks are found, contact your authorized dealer for repair or replacement.

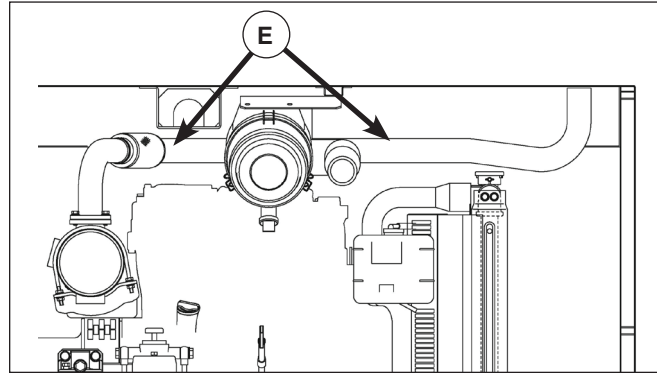

Check Electrical Terminals and Cable Connections



- Be sure to stop engine and remove black negative (-) battery cable before inspection.
- Be sure to wear appropriate personal protective equipment (PPE).

Check for any loose cables, damage on insulated covers, disconnected cables, short-circuits, etc., on the following items:

Generator

- Terminal connections of output terminal plate
- Main circuit of circuit breaker
- Terminal connection on control box
- Each terminal connection of each instrument
- Connectors

Engine

- Engine connectors
- Terminal connections

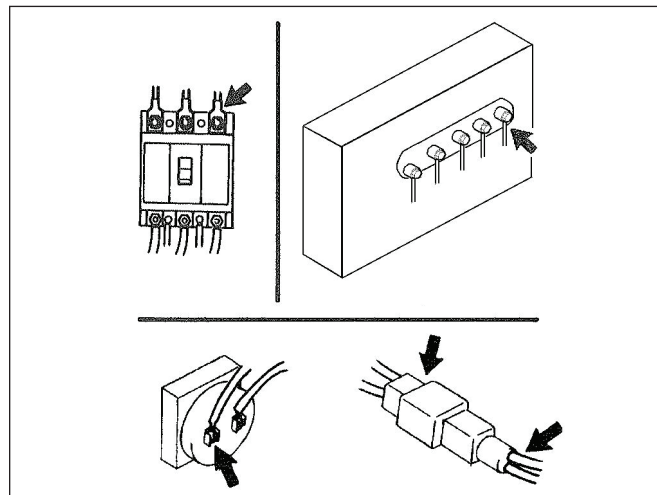

Change Air Filter Element

For filter element part number, see **Replacement Parts**.

1. Loosen latch (B), and remove cap (A). Clean interior of cap. Be sure O-ring (D) is properly seated in cap.
2. Dispose of old filter element (C), replacing with new.
3. Clean interior of case (E).
4. Install filter element into case, then install cap, securing with latch.

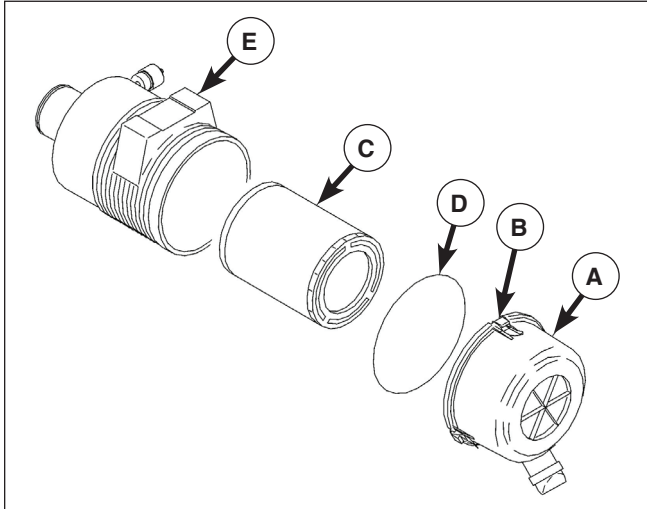

Check Vibration Isolator Rubbers

- The vibration isolation rubbers (F) support the generator and engine. Check the rubbers for any damage or deterioration.

Engine side: 2 places

Generator side: 2 places

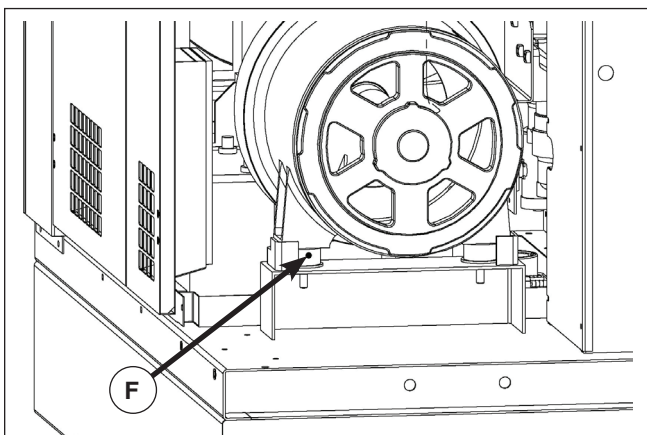

Check Rubber Hoses

- Check each rubber hose for damage or wear.
- If damage or wear is found, contact your authorized dealer for repair or replacement.

Change Coolant



WARNING

- Be sure to stop the machine and allow time to cool. Then loosen the radiator cap one notch. After the coolant water is sufficiently cooled and the inner pressure is released, take the cap off.

If this procedure is neglected, the inner pressure can blow off the cap. Steam jetting out of the radiator could result in causing scalding. Follow this procedure under all circumstances.

- LLC (Antifreeze) is a toxic material. If swallowed, seek immediate medical attention. Do not induce vomiting. If in eyes, wash eyes with clean running water and seek immediate medical attention. When storing, store in an approved container, clearly labeled 'LLC (Antifreeze) inside', away from children.
- Keep away from fire and flame.

1. To drain coolant, remove radiator cap (G), and loosen radiator drain valve (H). Also open drain valve on engine cylinder block (I). Be sure to drain coolant into an approved container.
2. After draining, close drain valves, then supply coolant through filler port (J). (Coolant capacity: approx. 2.8 gal (10 L).)
3. After filling with coolant, run machine in unloaded condition for approximately 2 to 3 minutes. Stop machine and check coolant level. Add as needed.
4. Dispose of used coolant according to local, state and/or federal regulations.

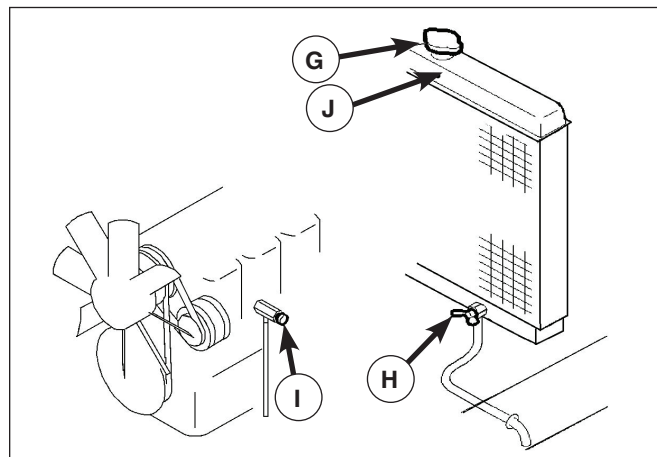

Grease Trailer Hub Bearing

Contact your authorized dealer.

Check Drawbar Hardware for Proper Tightness

Check tightness of drawbar hardware (A). Tighten to 140 lb-ft (190 Nm).

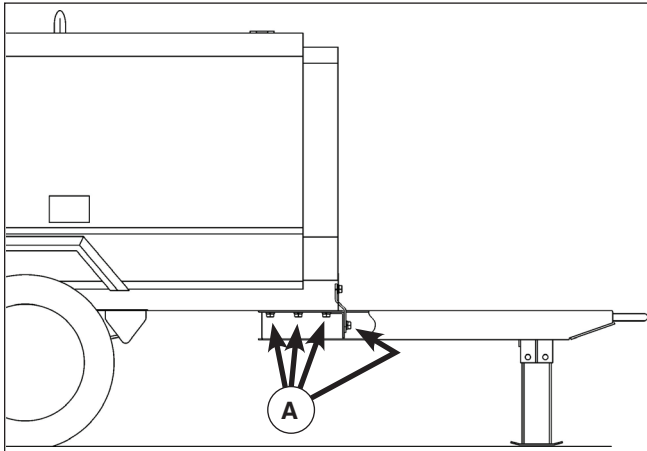

Check Undercarriage Bracket Hardware for Correct Tightness

Check tightness of undercarriage bracket hardware (B). Tighten to 100 lb-ft (136 Nm).

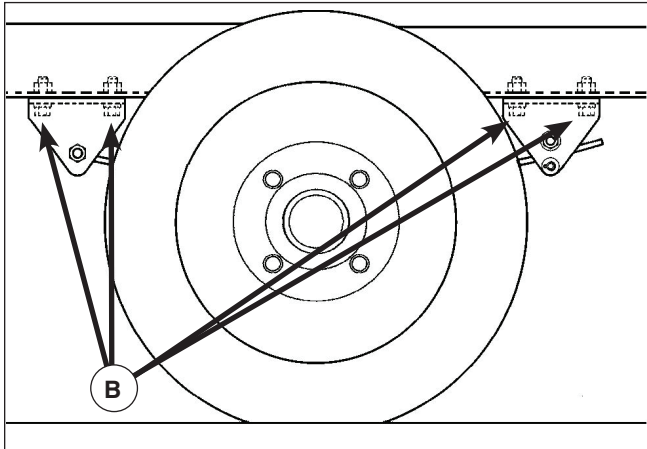

Check Wheel Lug Nuts / Tire Pressure

Check tightness of wheel lug nuts (C). Tighten to 80 lb-ft (108 Nm).

Also check tire pressure. Adjust to:

MP25 - 50 psi (345 kPa)

MP45 - 30 psi (207 kPa)

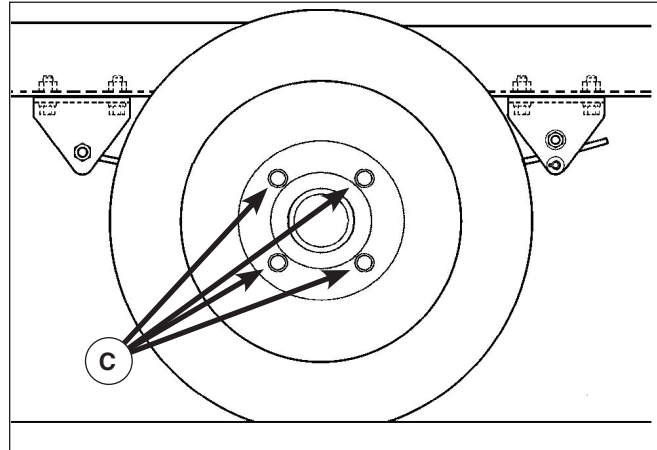

Periodic Load Operation

When a diesel engine driven generator is continuously operated with less light load than 30% or at no load for a long time, carbon will be stuck inside the exhaust pipe, exhaust muffler and engine. Unburned fuel will also leak sometimes from the turbo wastegate, connected portion of exhaust pipe, and the outlet port of muffler. If it is continuously operated under the conditions, the unburned fuel could ignite.

Moreover, carbon accumulation could cause engine power drop or overheating, resulting in engine damage.

Eliminate carbon accumulation by periodically burning it during operation with a load until the exhaust gas becomes almost clear.

(For load current, refer to the following table as a standard value.)

CAUTION

Increase the load factor, step by step, paying attention to the exhaust conditions. Also watch for sparks from the exhaust pipe that could result in a fire.

Type		MP25		MP45	
Frequency	Hz	60			
Rated Voltage	V	240	480	240	480
Load Current	A	48	24	86	43

Storage

Preparation for Long-term Storage

If the machine is left unused or not operated longer than six months:

- Store in a clean, dry place. Avoid leaving machine outside.
- Remove battery from machine, if possible, and store in a dry place.
- Charge battery (at least once every month).
- Drain engine oil from machine.
- Drain coolant and fuel from machine.*
- Seal engine, air-intake port and other openings with vinyl sheet, packing tape, etc., to protect from moisture and dust.
- Perform any necessary repairs or maintenance items.

Disposal of Products

In case of disposal of this unit, at first drain and dispose of all fluids according to local, state and/or federal regulations.

For further information, please contact your authorized dealer.

Troubleshooting

Troubleshooting Chart

Problem	Cause	Correction
Low starter revolution speed	1. Battery low or dead	1. Check battery; charge or replace as needed
Starter rotates but engine does not start	1. Fuel filter clogging 2. Fuel pre-filter clogging 3. No diesel fuel 4. Air mixing in fuel pipings 5. Controller Malfunction	1. Clean / replace 2. Clean / replace 3. Add diesel fuel 4. Bleed air 5. Contact authorized dealer
Low engine oil pressure, engine stops	1. Engine oil level low 2. Engine oil filter clogged 3. Faulty oil pressure switch 4. Loose or broken wire	1. Add engine oil 2. Replace 3. Contact authorized dealer 4. Connect; contact authorized dealer
Coolant temperature high, engine stops	1. Radiator clogged 2. Faulty thermostat 3. Faulty coolant temp switch 4. Belt slipping 5. Low coolant level 6. Loose or broken wire 7. Coolant temp sensor disconnected	1. Change coolant 2. Contact authorized dealer 3. Contact authorized dealer 4. Contact authorized dealer 5. Add coolant 6. Connect; contact authorized dealer 7. Contact authorized dealer
Air Filter Clogging monitor lamp flickers	1. Air filter clogging	1. Clean or replace
Oil Fence monitor lamp glows	1. Condensate (fuel, engine oil and coolant) accumulated in oil fence 2. Oil fence level switch not functioning	1. Drain condensate 2. Contact authorized dealer
Circuit breaker trips	1. Overloaded 2. Short circuit at load side	1. Reduce load 2. Remove and repair load
Even when operated at rated speed, no voltage or low voltage generated	1. Voltage regulator knob set too low 2. Circuit protector (CP) for AVR protection tripped 3. Internal problem	1. Adjust voltage regulator knob 2. Reset 3. Contact authorized dealer
Voltage generated too high when set at the rated frequency (50Hz/60Hz)	1. Voltage regulator knob set too high 2. Loose or disconnected wiring 3. Internal problem	1. Adjust voltage regulator knob 2. Check / connect wiring 3. Contact authorized dealer
Unstable voltage generation	1. Circuit protector (CP) for AVR protection tripped 2. Internal problem	1. Reset 2. Contact authorized dealer
Contact your authorized dealer for all other issues.		

Engine Trouble

This unit is equipped with a controller which diagnoses engine troubles. If engine trouble is detected:

1. Turn the starter switch to the RUN position.
2. Press and hold the diagnosis switch (A).
3. If there is engine trouble, the diagnosis lamp (B) will commence with a blinking pattern, indicating the trouble code. See **Diagnosis Lamp Lighting**.
4. Contact your authorized dealer with the trouble code for information on the issue and its correction.

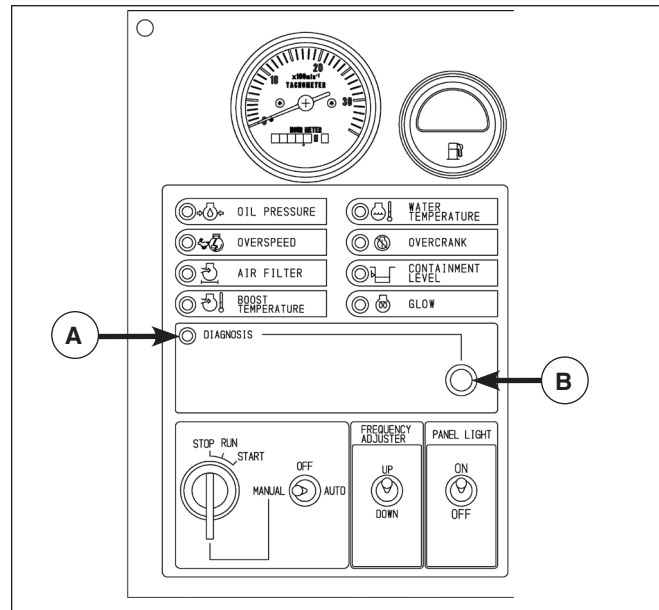

Diagnosis Lamp Lighting

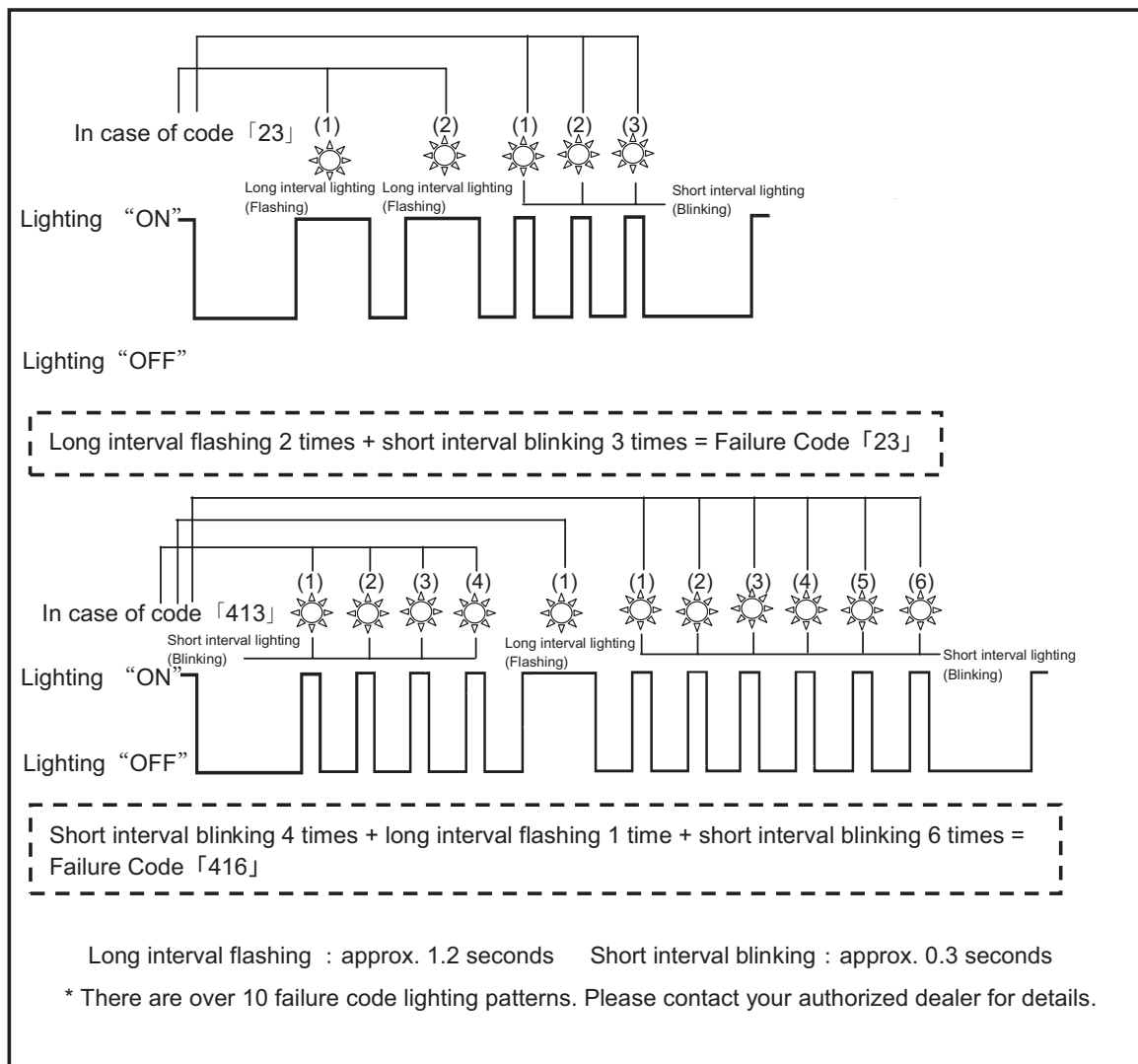

Specifications

Model		MP25			
Generator	Exciting system		Brushless		
	Armature connection		Star with neutral	ZigZag	
	Phase number		Three	Single	
	Power factor	%	80	100	
	Frequency	Hz	60		
	Rated output	kVA	25	14.4	
	Rated output	kW	20	14.4	
	Voltage	V	240	480	240 / 120
	Current	A	60	30	60
Engine	Model		Isuzu 4LE2T		
	Type		4-cycle, water-cooled, direct injection, turbo-charged, intercooled		
	No Cylinders		4		
	Total Displacement	cu in (L)	133 (2.179)		
	Rated Output	hp (kW)	33.3 (24.8)		
	Revolutions per minute	rpm (min ¹)	1800 (1800)		
	Lubricating Oil Capacity	gal (L)	2.75 (10.4)		
	Coolant Capacity (including Radiator)	gal (L)	2.75 (10.4)		
	Battery		80D26R (12V)		
Fuel Tank Capacity	gal (L)	51.5 (195)			
General Specifications	Overall Length	in (mm)	120.0 (3049)		
	Overall Length (Bonnet Only)	in (mm)	66.5 (1690)		
	Overall Width	in (mm)	61.0 (1549)		
	Overall Height	in (mm)	69.0 (1747)		
	Net Dry Mass	lb (kg)	2304 (1045)		
	Operating Mass	lb (kg)	2701 (1225)		

Model		MP45			
Generator	Exciting system		Brushless		
	Armature connection		Star with neutral	ZigZag	
	Phase number		Three	Single	
	Power factor	%	80	100	
	Frequency	Hz	60		
	Rated output	kVA	45	26	
	Rated output	kW	36	26	
	Voltage	V	240	480	240 / 120
	Current	A	108	54	108
Engine	Model		Isuzu 4LE2X		
	Type		4-cycle, direct injection supercharger, charge air cooler with water-cooled		
	No Cylinders		4		
	Total Displacement	cu in (L)	133 (2.179)		
	Rated Output	hp (kW)	57.7 (43.0)		
	Revolutions per minute	rpm (min ¹)	1800 (1800)		
	Lubricating Oil Capacity	gal (L)	3.1 (11.7)		
	Coolant Capacity (including Radiator)	gal (L)	2.5 (9.5)		
	Battery		85D26R (12V)		
Fuel Tank Capacity	gal (L)	106 (401)			
General Specifications	Overall Length	in (mm)	140.0 (3566)		
	Overall Length (Bonnet Only)	in (mm)	82.0 (2080)		
	Overall Width	in (mm)	66.0 (1676)		
	Overall Height	in (mm)	71.0 (1808)		
	Net Dry Mass	lb (kg)	3445 (1563)		
	Operating Mass	lb (kg)	4217 (1913)		

Wiring Diagram

MP25

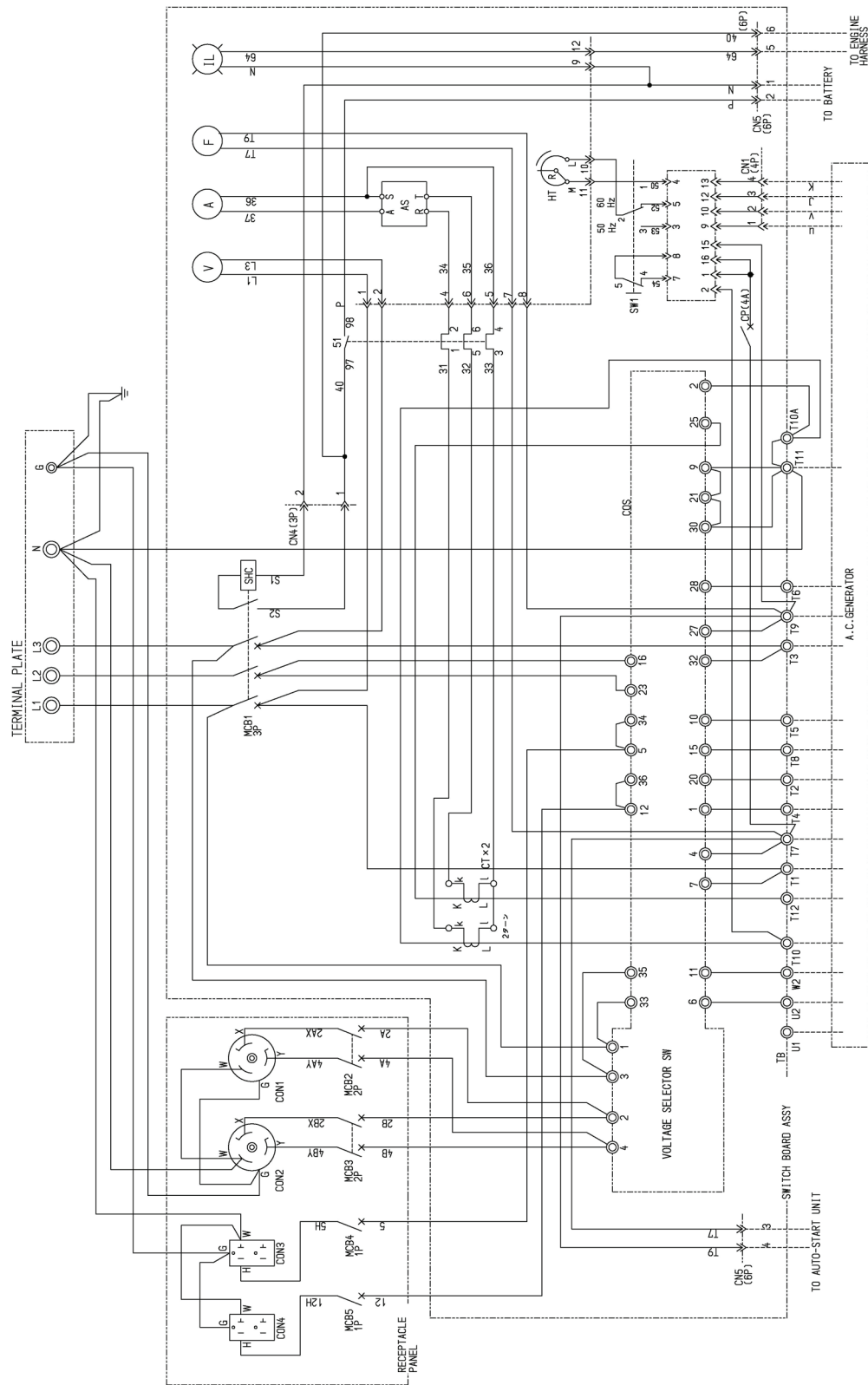

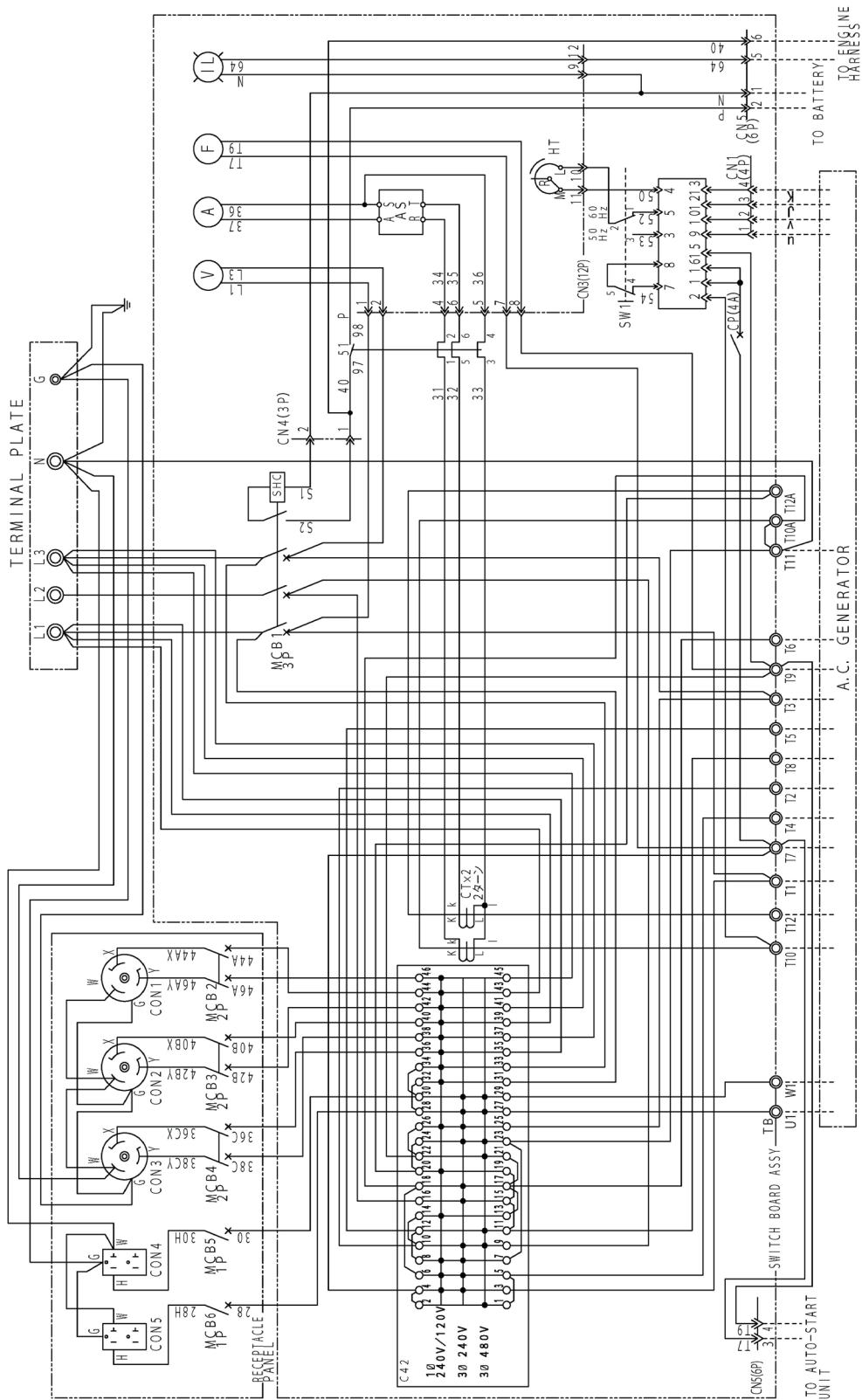

Engine - All Models

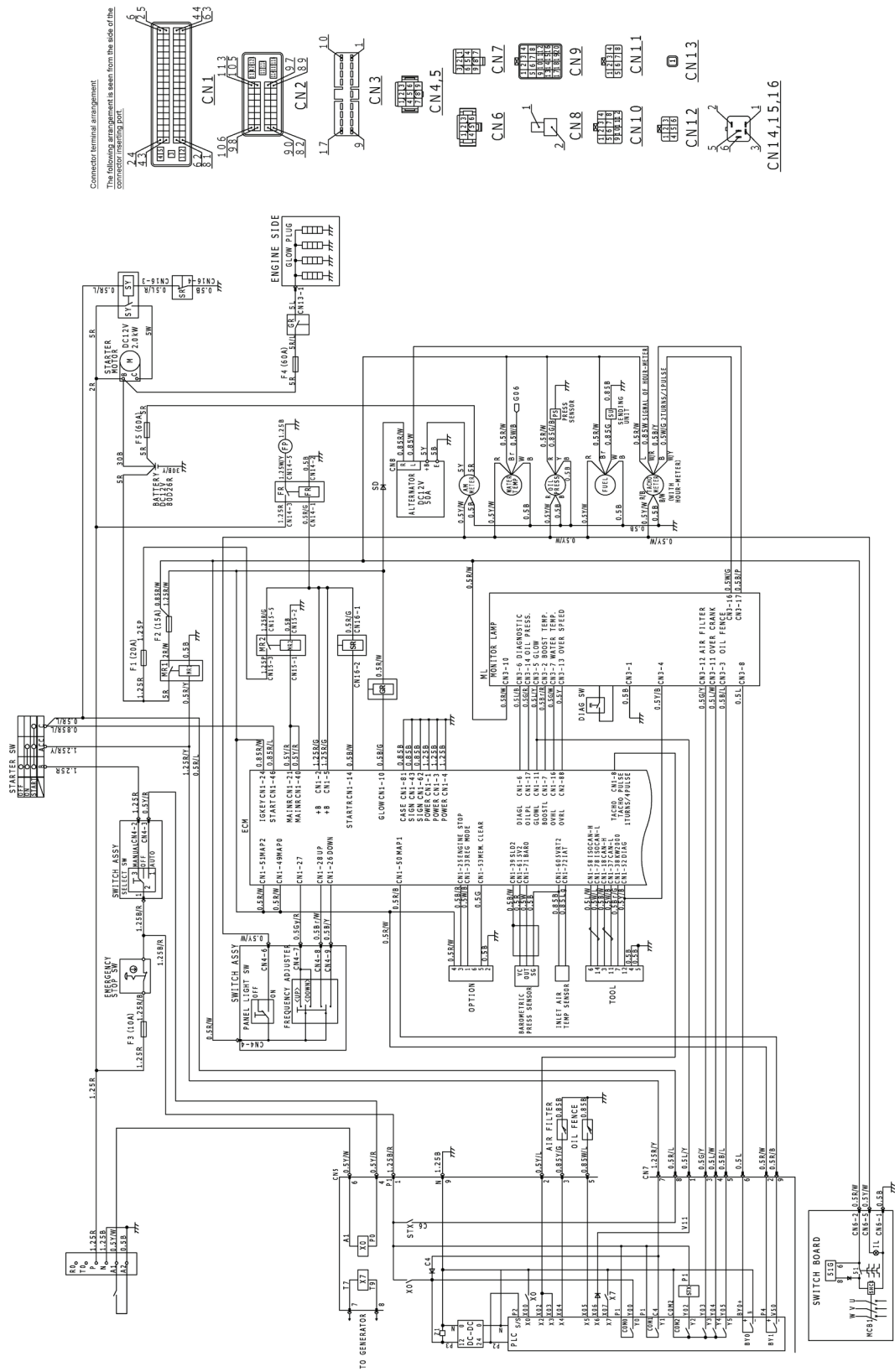

Connector terminal arrangement
The following arrangement is seen from the side of the connector mating port.

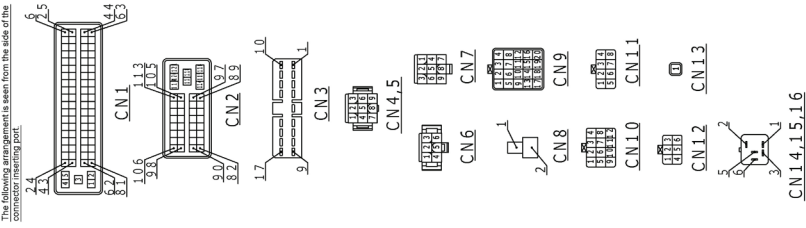

Sensors - All Models

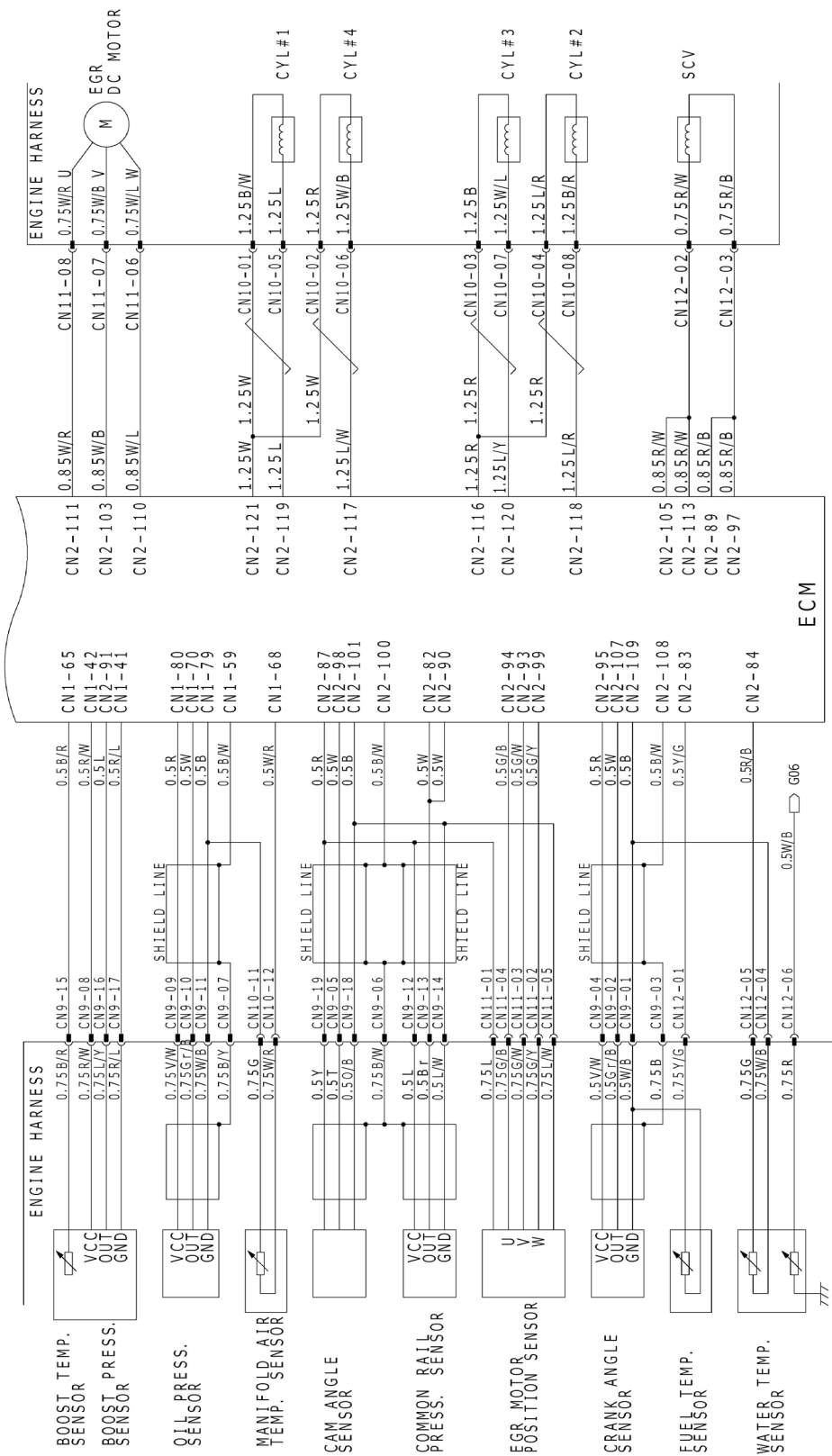

Fuel Piping Diagram

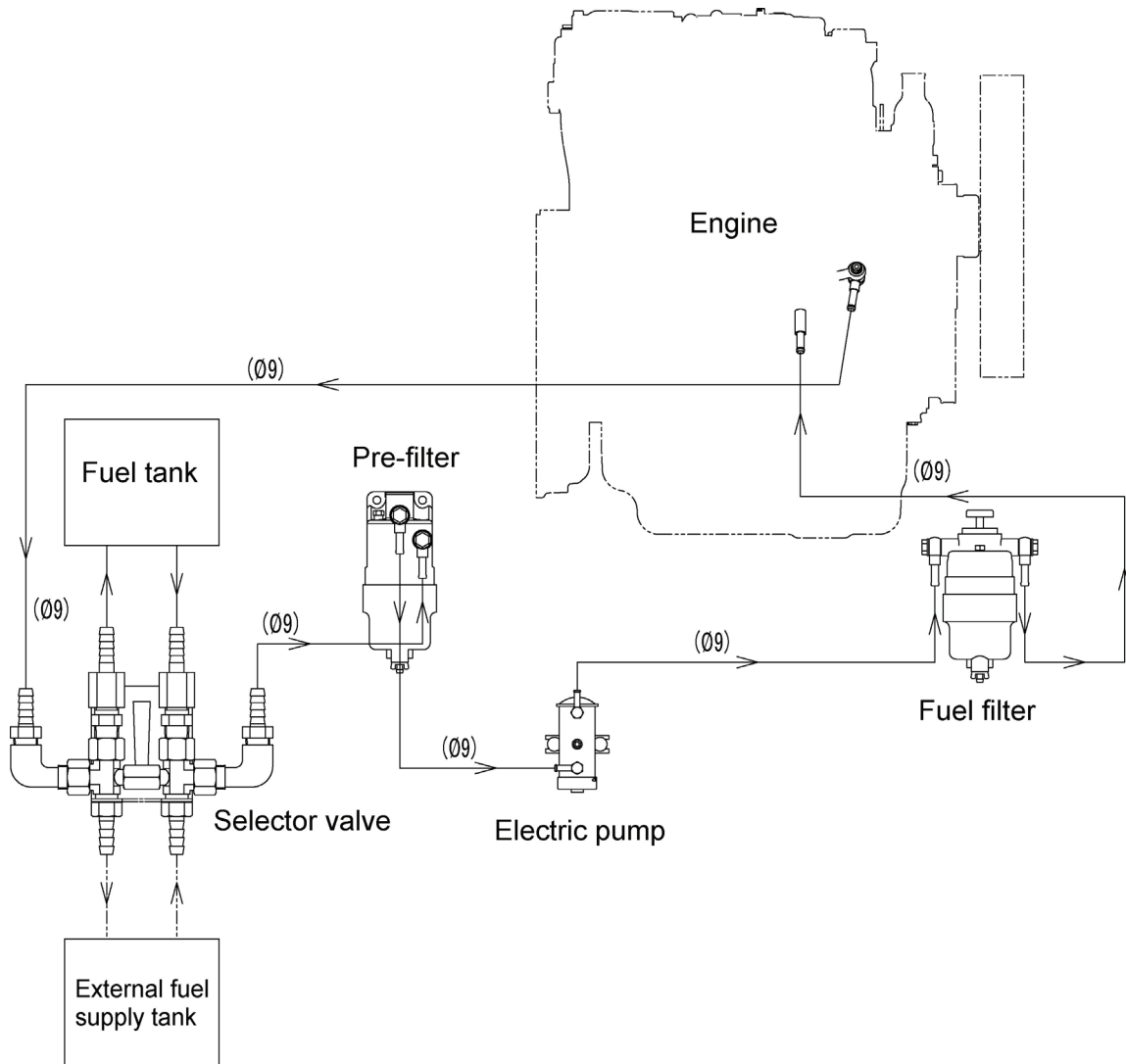

Addendum A - Cam Locks / Arctic Kit

NOTE: Location and configuration of kit components may differ according to model.

Cam Lock Receptacles

The cam lock receptacles allow for quick connection and disconnection of loads.

1. Connect the cam lock connectors from the load to the cam lock receptacles on the lower portion of the outlet panel on the unit. See Figure A1. Be sure to connect the load correctly. See **Connecting Loads**.



WARNING

Electrocution Hazard. Do not connect or disconnect loads to the cam lock receptacles while the unit is in operation.

NOTICE: Do not operate the voltage selector switch while the unit is in operation. Unit damage may result.

Arctic Kit

Block Heater / Battery Heater

The block heater / battery heater keeps the engine block and battery heated while the unit is stored or not in use.

The block heater / battery heater should be used whenever the unit is stored or not in use in temperatures below 32° F (0° C).

1. Plug the female end of a heavy-duty power cord (not supplied) into the Block Heater / Battery Heater recessed receptacle (A, Figure A2).
2. Plug the male end of the power cord into a standard 120V outlet.
3. Unplug the block heater / battery heater before putting the unit into operation.

Battery Charger

The battery charger keeps the battery charged while the unit is stored or not in use.

1. Plug the female end of a heavy-duty power cord (not supplied) into the Battery Charger recessed receptacle (B, Figure A2).
2. Plug the male end of the power cord into a standard 120V outlet.
3. The red light (A, Figure A3) on the battery charger module, located in the left front section of the engine compartment (see Figure A3) indicates the battery is charging. The green light (B) indicates full charge. (The battery charger can stay plugged in after the battery reaches full charge without damaging the battery.)
4. Unplug the battery charger before putting the unit into operation.

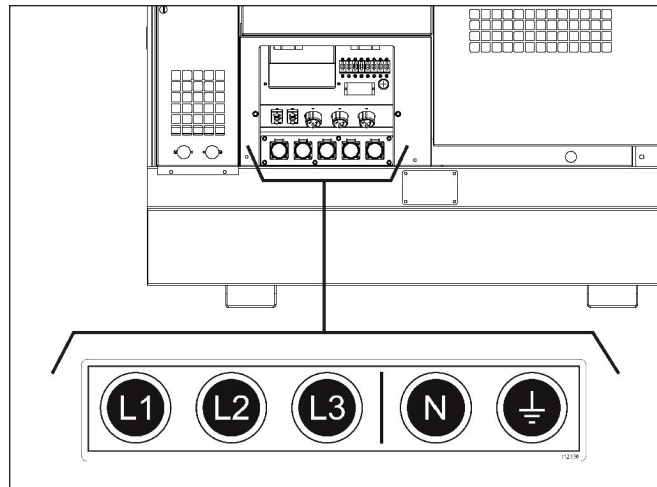

Figure A1

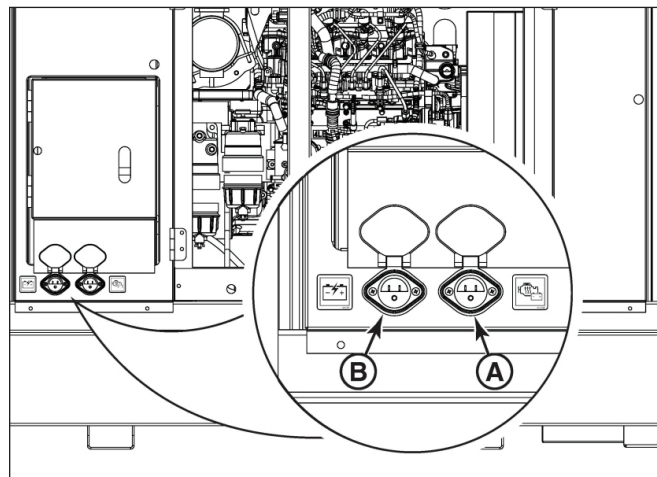

Figure A2

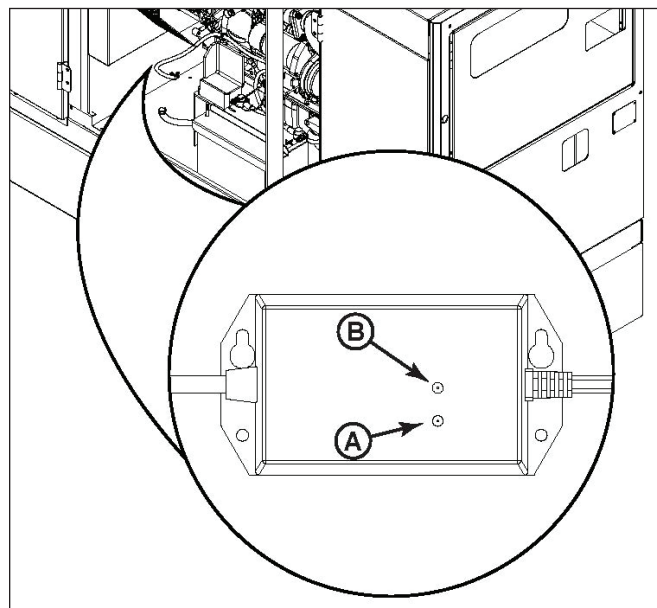

Figure A3

Addendum B - Misc Unit Options

Battery Charger

The optional battery charger keeps the battery charged while the unit is stored or not in use.

Refer to **Battery Charger** in **Addendum A - Cam Locks / Arctic Kit**.

Battery Disconnect

The optional battery disconnect allows convenient, tool-free disconnection of the battery while the unit is in storage or not in use, or to prevent unauthorized unit operation.

To disconnect the battery:

1. Turn the switch (C, Figure A4) to the Disconnect position (D).
2. A padlock (not supplied) can be used for added security.

To connect the battery:

1. Remove the padlock (if used).
2. Turn the switch to the Connect position (E, Figure A4).

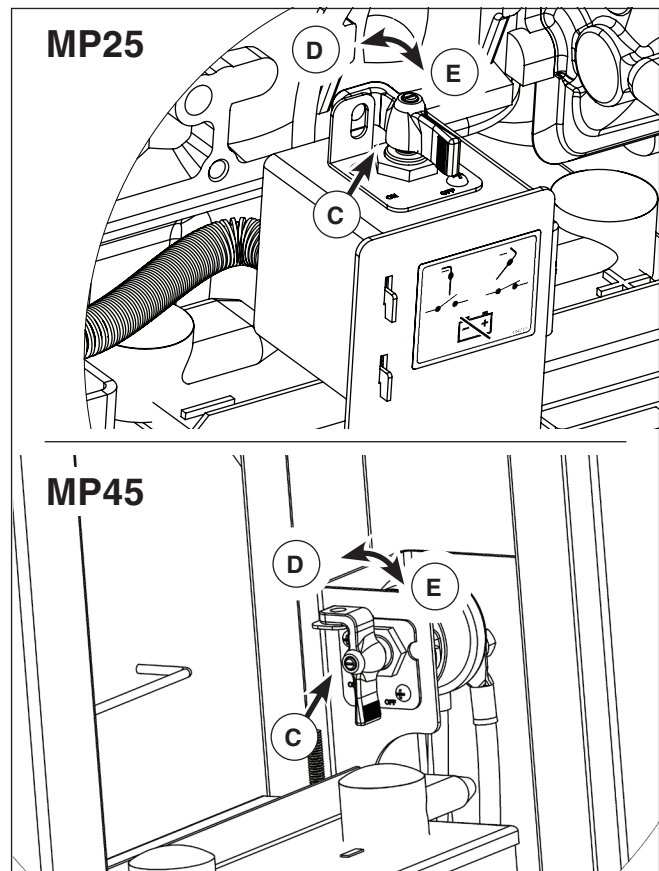

Figure A4

Addendum C - Tire Safety Information

This portion of the User's Manual contains tire safety information as required by 49 CFR 575.6.

Section 1.1 contains "Steps for Determining Correct Load Limit - Trailer".

Section 1.2 contains "Steps for Determining Correct Load Limit – Tow Vehicle".

Section 1.3 contains a Glossary of Tire Terminology, including "cold inflation pressure", "maximum inflation pressure", "recommended inflation pressure", and other non-technical terms.

Section 1.4 contains information from the NHTSA brochure entitled "Tire Safety – Everything Rides On It". This brochure, as well as the preceding subsections, describes the following items:

- Tire labeling, including a description and explanation of each marking on the tires, and information about the DOT Tire Identification Number (TIN).
- Recommended tire inflation pressure, including a description and explanation of:
 - A. Cold inflation pressure.
 - B. Vehicle Placard and location on the vehicle.
 - C. Adverse safety consequences of under inflation (including tire failure).
 - D. Measuring and adjusting air pressure for proper inflation.
- Tire Care, including maintenance and safety practices.
- Vehicle load limits, including a description and explanation of the following items:
 - A. Locating and understanding the load limit information, total load capacity, and cargo capacity.
 - B. Calculating total and cargo capacities with varying seating configurations including quantitative examples showing / illustrating how the vehicles cargo and luggage capacity decreases as combined number and size of occupants' increases. This item is also discussed in Section 3.
 - C. Determining compatibility of tire and vehicle load capabilities.
 - D. Adverse safety consequences of overloading on handling and stopping on tires.

1.1. STEPS FOR DETERMINING CORRECT LOAD LIMIT – TRAILER

Determining the load limits of a trailer includes more than understanding the load limits of the tires alone. On all trailers there is a Federal certification/VIN label that is located on the forward half of the left (road) side of the unit. This certification/VIN label will indicate the trailer's Gross Vehicle Weight Rating (GVWR). This is the most weight the fully loaded trailer can weigh. It will also provide the Gross Axle Weight Rating (GAWR). This is the most a particular axle can weigh. If there are multiple axles, the GAWR of each axle will be provided.

If your trailer has a GVWR of 10,000 pounds or less, there is a vehicle placard located in the same location as the certification label described above. This placard provides tire and loading information. In addition, this placard will show a statement regarding maximum cargo capacity. Cargo can be added to the trailer, up to the maximum weight specified on the placard. The combined weight of the cargo is provided as a single number. In any case, remember: the total weight of a fully loaded trailer can not exceed the stated GVWR.

For trailers with living quarters installed, the weight of water and propane also need to be considered. The weight of fully filled propane containers is considered part of the weight of the trailer before it is loaded with cargo, and is not considered part of the disposable cargo load. Water however, is a disposable cargo weight and is treated as such. If there is a fresh water storage tank of 100 gallons, this tank when filled would weigh about 800 pounds. If more cargo is being transported, water can be off-loaded to keep the total amount of cargo added to the vehicle within the limits of the GVWR so as not to overload the vehicle. Understanding this flexibility will allow you, the owner, to make choices that fit your travel needs.

When loading your cargo, be sure it is distributed evenly to prevent overloading front to back and side to side. Heavy items should be placed low and as close to the axle positions as reasonable. Too many items on one side may overload a tire. The best way to know the actual weight of the vehicle is to weigh it at a public scale. Talk to your dealer to discuss the weighing methods needed to capture the various weights related to the trailer. This would include the weight empty or unloaded, weights per axle, wheel, hitch or king-pin, and total weight.

Excessive loads and/or underinflation cause tire overloading and, as a result, abnormal tire flexing occurs. This situation can generate an excessive amount of heat within the tire. Excessive heat may lead to tire failure. It is the air pressure that enables a tire to support the load, so proper inflation is critical. The proper air pressure may be found on the certification/VIN label and/or on the Tire Placard. This value should never exceed the maximum cold inflation pressure stamped on the tire.

1.1.1. TRAILERS 10,000 POUNDS GVWR OR LESS

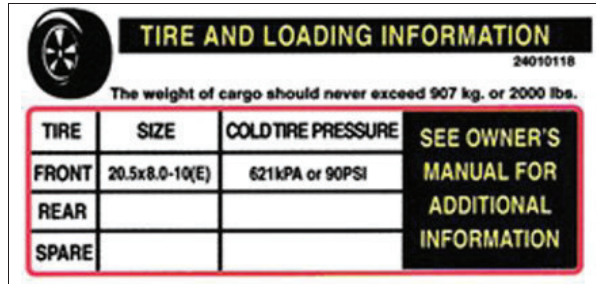

Tire and Loading Information Placard – Figure 1-1

1. Locate the statement, “The weight of cargo should never exceed XXX kg or XXX lbs.,” on your vehicle’s placard. See figure 1-1.
2. This figure equals the available amount of cargo and luggage load capacity.
3. Determine the combined weight of luggage and cargo being loaded on the vehicle. That weight may not safely exceed the available cargo and luggage load capacity.

The trailer’s placard refers to the Tire Information Placard attached adjacent to or near the trailer’s VIN (Certification) label at the left front of the trailer.

1.1.2. TRAILERS OVER 10,000 POUNDS GVWR (NOTE: THESE TRAILERS ARE NOT REQUIRED TO HAVE A TIRE INFORMATION PLACARD ON THE VEHICLE)

1. Determine the empty weight of your trailer by weighing the trailer using a public scale or other means. This step does not have to be repeated.
2. Locate the GVWR (Gross Vehicle Weight Rating) of the trailer on your trailer’s VIN (Certification) label.
3. Subtract the empty weight of your trailer from the GVWR stated on the VIN label. That weight is the maximum available cargo capacity of the trailer and may not be safely exceeded.

1.2. STEPS FOR DETERMINING CORRECT LOAD LIMIT – TOW VEHICLE

1. Locate the statement, “The combined weight of occupants and cargo should never exceed XXX lbs.,” on your vehicle’s placard.
2. Determine the combined weight of the driver and passengers who will be riding in your vehicle.
3. Subtract the combined weight of the driver and passengers from XXX kilograms or XXX pounds.
4. The resulting figure equals the available amount of cargo and luggage capacity. For example, if the “XXX” amount equals 1400 lbs. and there will be five 150 lb. passengers in your vehicle, the amount of available cargo and luggage capacity is 650 lbs. (1400-750 (5 x 150) = 650 lbs.).
5. Determine the combined weight of luggage and cargo being loaded on the vehicle. That weight may not safely exceed the available cargo and luggage capacity calculated in Step # 4.
6. If your vehicle will be towing a trailer, load from your trailer will be transferred to your vehicle. Consult the tow vehicle’s manual to determine how this weight transfer reduces the available cargo and luggage capacity of your vehicle.

1.3. GLOSSARY OF TIRE TERMINOLOGY

Accessory weight

The combined weight (in excess of those standard items which may be replaced) of automatic transmission, power steering, power brakes, power windows, power seats, radio and heater, to the extent that these items are available as factory-installed equipment (whether installed or not).

Bead

The part of the tire that is made of steel wires, wrapped or reinforced by ply cords and that is shaped to fit the rim.

Bead separation

This is the breakdown of the bond between components in the bead.

Bias ply tire

A pneumatic tire in which the ply cords that extend to the beads are laid at alternate angles substantially less than 90 degrees to the centerline of the tread.

Carcass

The tire structure, except tread and sidewall rubber which, when inflated, bears the load.

Chunking

The breaking away of pieces of the tread or sidewall.

Cold inflation pressure

The pressure in the tire before you drive.

Cord

The strands forming the plies in the tire.

Cord separation

The parting of cords from adjacent rubber compounds.

Cracking

Any parting within the tread, sidewall, or inner liner of the tire extending to cord material.

CT

A pneumatic tire with an inverted flange tire and rim system in which the rim is designed with rim flanges pointed radially inward and the tire is designed to fit on the underside of the rim in a manner that encloses the rim flanges inside the air cavity of the tire.

Curb weight

The weight of a motor vehicle with standard equipment including the maximum capacity of fuel, oil, and coolant, and, if so equipped, air conditioning and additional weight optional engine.

Extra load tire

A tire designed to operate at higher loads and at higher inflation pressures than the corresponding standard tire.

Groove

The space between two adjacent tread ribs.

Gross Axle Weight Rating

The maximum weight that any axle can support, as published on the Certification / VIN label on the front left side of the trailer. Actual weight determined by weighing each axle on a public scale, with the trailer attached to the towing vehicle.

Gross Vehicle Weight Rating

The maximum weight of the fully loaded trailer, as published on the Certification / VIN label. Actual weight determined by weighing trailer on a public scale, without being attached to the towing vehicle.

Hitch Weight

The downward force exerted on the hitch ball by the trailer coupler.

Innerliner

The layer(s) forming the inside surface of a tubeless tire that contains the inflating medium within the tire.

Innerliner separation

The parting of the innerliner from cord material in the carcass.

Intended outboard sidewall

The sidewall that contains a white-wall, bears white lettering or bears manufacturer, brand, and/or model name molding that is higher or deeper than the same molding on the other sidewall of the tire or the outward facing sidewall of an asymmetrical tire that has a particular side that must always face outward when mounted on a vehicle.

Light truck (LT) tire

A tire designated by its manufacturer as primarily intended for use on lightweight trucks or multipurpose passenger vehicles.

Load rating

The maximum load that a tire is rated to carry for a given inflation pressure.

Maximum load rating

The load rating for a tire at the maximum permissible inflation pressure for that tire.

Maximum permissible inflation pressure

The maximum cold inflation pressure to which a tire may be inflated.

Maximum loaded vehicle weight

The sum of curb weight, accessory weight, vehicle capacity weight, and production options weight.

Measuring rim

The rim on which a tire is fitted for physical dimension requirements.

Pin Weight

The downward force applied to the 5th wheel or gooseneck ball, by the trailer kingpin or gooseneck coupler.

Non-pneumatic rim

A mechanical device which, when a non-pneumatic tire assembly incorporates a wheel, supports the tire, and attaches, either integrally or separably, to the wheel center member and upon which the tire is attached.

Non-pneumatic spare tire assembly

A non-pneumatic tire assembly intended for temporary use in place of one of the pneumatic tires and rims that are fitted to a passenger car in compliance with the requirements of this standard.

Non-pneumatic tire

A mechanical device which transmits, either directly or through a wheel or wheel center member, the vertical load and tractive forces from the roadway to the vehicle, generates the tractive forces that provide the directional control of the vehicle and does not rely on the containment of any gas or fluid for providing those functions.

Non-pneumatic tire assembly

A non-pneumatic tire, alone or in combination with a wheel or wheel center member, which can be mounted on a vehicle.

Normal occupant weight

This means 68 kilograms (150 lbs.) times the number of occupants specified in the second column of Table I of 49 CFR 571.110.

Occupant distribution

The distribution of occupants in a vehicle as specified in the third column of Table I of 49 CFR 571.110.

Open splice

Any parting at any junction of tread, sidewall, or innerliner that extends to cord material.

Outer diameter

The overall diameter of an inflated new tire.

Overall width

The linear distance between the exteriors of the sidewalls of an inflated tire, including elevations due to labeling, decorations, or protective bands or ribs.

Ply

A layer of rubber-coated parallel cords.

Ply separation

A parting of rubber compound between adjacent plies.

Pneumatic tire

A mechanical device made of rubber, chemicals, fabric and steel or other materials, that, when mounted on an automotive wheel, provides the traction and contains the gas or fluid that sustains the load.

Production options weight

The combined weight of those installed regular production options weighing over 2.3 kilograms (5 lbs.) in excess of those standard items which they replace, not previously considered in curb weight or accessory weight, including heavy duty brakes, ride levelers, roof rack, heavy duty battery, and special trim.

Radial ply tire

A pneumatic tire in which the ply cords that extend to the beads are laid at substantially 90 degrees to the centerline of the tread.

Recommended inflation pressure

This is the inflation pressure provided by the vehicle manufacturer on the Tire Information label and on the Certification / VIN tag.

Reinforced tire

A tire designed to operate at higher loads and at higher inflation pressures than the corresponding standard tire.

Rim

A metal support for a tire or a tire and tube assembly upon which the tire beads are seated.

Rim diameter

This means the nominal diameter of the bead seat.

Rim size designation

This means the rim diameter and width.

Rim type designation

This means the industry of manufacturer's designation for a rim by style or code.

Rim width

This means the nominal distance between rim flanges.

Section width

The linear distance between the exteriors of the sidewalls of an inflated tire, excluding elevations due to labeling, decoration, or protective bands.

Sidewall

That portion of a tire between the tread and bead.

Sidewall separation

The parting of the rubber compound from the cord material in the sidewall.

Special Trailer (ST) tire

The "ST" is an indication the tire is for trailer use only.

Test rim

The rim on which a tire is fitted for testing, and may be any rim listed as appropriate for use with that tire.

Tread

That portion of a tire that comes into contact with the road.

Tread rib

A tread section running circumferentially around a tire.

Tread separation

Pulling away of the tread from the tire carcass.

Treadwear indicators (TWI)

The projections within the principal grooves designed to give a visual indication of the degrees of wear of the tread.

Vehicle capacity weight

The rated cargo and luggage load plus 68 kilograms (150 lbs.) times the vehicle's designated seating capacity.

Vehicle maximum load on the tire

The load on an individual tire that is determined by distributing to each axle its share of the maximum loaded vehicle weight and dividing by two.

Vehicle normal load on the tire

The load on an individual tire that is determined by distributing to each axle its share of the curb weight, accessory weight, and normal occupant weight (distributed in accordance with Table I of CRF 49 571.110) and dividing by 2.

Weather side

The surface area of the rim not covered by the inflated tire.

Wheel center member

In the case of a non-pneumatic tire assembly incorporating a wheel, a mechanical device which attaches, either integrally or separably, to the non-pneumatic rim and provides the connection between the non-pneumatic rim and the vehicle; or, in the case of a non-pneumatic tire assembly not incorporating a wheel, a mechanical device which attaches, either integrally or separably, to the non-pneumatic tire and provides the connection between tire and the vehicle.

Wheel-holding fixture

The fixture used to hold the wheel and tire assembly securely during testing.

1.4. TIRE SAFETY - EVERYTHING RIDES ON IT

The National Traffic Safety Administration (NHTSA) has published a brochure (DOT HS 809 361) that discusses all aspects of Tire Safety, as required by CFR 575.6. This brochure is reproduced in part below. It can be obtained and downloaded from NHTSA, free of charge, from the following web site:

http://www.nhtsa.dot.gov/cars/rules/TireSafety/ridesonit/tires_index.html

Studies of tire safety show that maintaining proper tire pressure, observing tire and vehicle load limits (not carrying more weight in your vehicle than your tires or vehicle can safely handle), avoiding road hazards, and inspecting tires for cuts, slashes, and other irregularities are the most important things you can do to avoid tire failure, such as tread separation or blowout and flat tires. These actions, along with other care and maintenance activities, can also:

- Improve vehicle handling
- Help protect you and others from avoidable breakdowns and accidents
- Improve fuel economy
- Increase the life of your tires.

This booklet presents a comprehensive overview of tire safety, including information on the following topics:

- Basic tire maintenance
- Uniform Tire Quality Grading System
- Fundamental characteristics of tires

- Tire safety tips.

Use this information to make tire safety a regular part of your vehicle maintenance routine. Recognize that the time you spend is minimal compared with the inconvenience and safety consequences of a flat tire or other tire failure.

1.5. SAFETY FIRST—BASIC TIRE MAINTENANCE

Properly maintained tires improve the steering, stopping, traction, and load-carrying capability of your vehicle. Underinflated tires and overloaded vehicles are a major cause of tire failure. Therefore, as mentioned above, to avoid flat tires and other types of tire failure, you should maintain proper tire pressure, observe tire and vehicle load limits, avoid road hazards, and regularly inspect your tires.

1.5.1. FINDING YOUR VEHICLE'S RECOMMENDED TIRE PRESSURE AND LOAD LIMITS

Tire information placards and vehicle certification labels contain information on tires and load limits. These labels indicate the vehicle manufacturer's information including:

- Recommended tire size
- Recommended tire inflation pressure
- Vehicle capacity weight (VCW—the maximum occupant and cargo weight a vehicle is designed to carry)
- Front and rear gross axle weight ratings (GAWR—the maximum weight the axle systems are designed to carry).

Both placards and certification labels are permanently attached to the trailer near the left front.

1.5.2. UNDERSTANDING TIRE PRESSURE AND LOAD LIMITS

Tire inflation pressure is the level of air in the tire that provides it with load-carrying capacity and affects the overall performance of the vehicle. The tire inflation pressure is a number that indicates the amount of air pressure—measured in pounds per square inch (psi)—a tire requires to be properly inflated. (You will also find this number on the vehicle information placard expressed in kilopascals (kpa), which is the metric measure used internationally.)

Manufacturers of passenger vehicles and light trucks determine this number based on the vehicle's design load limit, that is, the greatest amount of weight a vehicle can safely carry and the vehicle's tire size. The proper tire pressure for your vehicle is referred to as the "recommended cold inflation pressure." (As you will read below, it is difficult to obtain the recommended tire pressure if your tires are not cold.) Because tires are designed to be used on more than one type of vehicle, tire manufacturers list the "maximum permissible inflation pressure" on the tire sidewall. This number is the greatest amount of air pressure that should ever be put in the tire under normal driving conditions.

1.5.3. CHECKING TIRE PRESSURE

It is important to check your vehicle's tire pressure at least once a month for the following reasons:

- Most tires may naturally lose air over time.
- Tires can lose air suddenly if you drive over a pothole or other object or if you strike the curb when parking.
- With radial tires, it is usually not possible to determine underinflation by visual inspection.

For convenience, purchase a tire pressure gauge to keep in your vehicle. Gauges can be purchased at tire dealerships, auto supply stores, and other retail outlets. The recommended tire inflation pressure that vehicle manufacturers provide reflects the proper psi when a tire is cold. The term cold does not relate to the outside temperature. Rather, a cold tire is one that has not been driven on for at least three hours. When you drive, your tires get warmer, causing the air pressure within them to increase. Therefore, to get an accurate tire pressure reading, you must measure tire pressure when the tires are cold or compensate for the extra pressure in warm tires.

1.5.4. STEPS FOR MAINTAINING PROPER TIRE PRESSURE

- Step 1: Locate the recommended tire pressure on the vehicle's tire information placard, certification label, or in the owner's manual.
- Step 2: Record the tire pressure of all tires.
- Step 3: If the tire pressure is too high in any of the tires, slowly release air by gently pressing on the tire valve stem with the edge of your tire gauge until you get to the correct pressure.
- Step 4: If the tire pressure is too low, note the difference between the measured tire pressure and the correct tire pressure. These "missing" pounds of pressure are what you will need to add.
- Step 5: At a service station, add the missing pounds of air pressure to each tire that is underinflated.
- Step 6: Check all the tires to make sure they have the same air pressure (except in cases in which the front and rear tires are supposed to have different amounts of pressure).

If you have been driving your vehicle and think that a tire is underinflated, fill it to the recommended cold inflation pressure indicated on your vehicle's tire information placard or certification label. While your tire may still be slightly underinflated due to the extra pounds of pressure in the warm tire, it is safer to drive with air pressure that is slightly lower than the vehicle manufacturer's recommended cold inflation pressure than to drive with a significantly underinflated tire. Since this is a temporary fix, don't forget to recheck and adjust the tire's pressure when you can obtain a cold reading.

1.5.5. TIRE SIZE

To maintain tire safety, purchase new tires that are the same size as the vehicle's original tires or another size recommended by the manufacturer. Look at the tire information placard, the owner's manual, or the sidewall of the tire you are replacing to find this information. If you have any doubt about the correct size to choose, consult with the tire dealer.

1.5.6. TIRE TREAD

The tire tread provides the gripping action and traction that prevent your vehicle from slipping or sliding, especially when the road is wet or icy. In general, tires are not safe and should be replaced when the tread is worn down to 1/16 of an inch. Tires have built-in treadwear indicators that let you know when it is time to replace your tires. These indicators are raised sections spaced intermittently in the bottom of the tread grooves. When they appear "even" with the outside of the tread, it is time to replace your tires. Another method for checking tread depth is to place a penny in the tread with Lincoln's head upside down and facing you. If you can see the top of Lincoln's head, you are ready for new tires.

1.5.7. TIRE BALANCE AND WHEEL ALIGNMENT

To avoid vibration or shaking of the vehicle when a tire rotates, the tire must be properly balanced. This balance is achieved by positioning weights on the wheel to counterbalance heavy spots on the wheel-and-tire assembly. A wheel alignment adjusts the angles of the wheels so that they are positioned correctly relative to the vehicle's frame. This adjustment maximizes the life of your tires. These adjustments require special equipment and should be performed by a qualified technician.

1.5.8. TIRE REPAIR

The proper repair of a punctured tire requires a plug for the hole and a patch for the area inside the tire that surrounds the puncture hole. Punctures through the tread can be repaired if they are not too large, but punctures to the sidewall should not be repaired. Tires must be removed from the rim to be properly inspected before being plugged and patched.

1.5.9. TIRE FUNDAMENTALS

Federal law requires tire manufacturers to place standardized information on the sidewall of all tires. This information identifies and describes the fundamental characteristics of the tire and also provides a tire identification number for safety standard certification and in case of a recall.

1.5.9.1. Information on Passenger Vehicle Tires

Please refer to the diagram below.

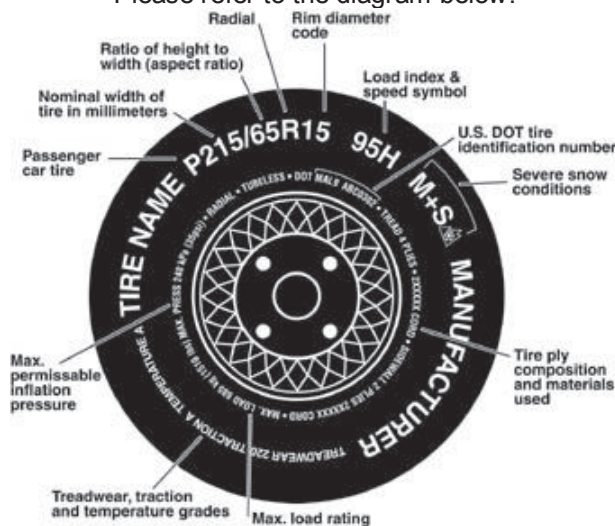

P

The "P" indicates the tire is for passenger vehicles.

Next number

This three-digit number gives the width in millimeters of the tire from sidewall edge to sidewall edge. In general, the larger the number, the wider the tire.

Next number

This two-digit number, known as the aspect ratio, gives the tire's ratio of height to width. Numbers of 70 or lower indicate a short sidewall for improved steering response and better overall handling on dry pavement.

R

The "R" stands for radial. Radial ply construction of tires has been the industry standard for the past 20 years.

Next number

This two-digit number is the wheel or rim diameter in inches. If you change your wheel size, you will have to purchase new tires to match the new wheel diameter.

Next number

This two- or three-digit number is the tire's load index. It is a measurement of how much weight each tire can support. You may find this information in your owner's manual. If not, contact a local tire dealer. Note: You may not find this information on all tires because it is not required by law.

M+S

The "M+S" or "M/S" indicates that the tire has some mud and snow capability. Most radial tires have these markings; hence, they have some mud and snow capability.

Speed Rating

The speed rating denotes the speed at which a tire is designed to be driven for extended periods of time. The ratings range from 99 miles per hour (mph) to 186 mph. These ratings are listed below. Note: You may not find this information on all tires because it is not required by law.

Tire Safety Information

Letter Rating	Speed Rating
Q	99 mph
R	106 mph
S	112 mph
T	118 mph
U	124 mph
H	130 mph
V	149 mph
W	168* mph
Y	186* mph

* For tires with a maximum speed capability over 149 mph, tire manufacturers sometimes use the letters ZR. For those with a maximum speed capability over 186 mph, tire manufacturers always use the letters ZR.

U.S. DOT Tire Identification Number

This begins with the letters "DOT" and indicates that the tire meets all federal standards. The next two numbers or letters are the plant code where it was manufactured, and the last four numbers represent the week and year the tire was built. For example, the numbers 3197 means the 31st week of 1997. The other numbers are marketing codes used at the manufacturer's discretion. This information is used to contact consumers if a tire defect requires a recall.

Tire Ply Composition and Materials Used

The number of plies indicates the number of layers of rubber-coated fabric in the tire. In general, the greater the number of plies, the more weight a tire can support. Tire manufacturers also must indicate the materials in the tire, which include steel, nylon, polyester, and others.

Maximum Load Rating

This number indicates the maximum load in kilograms and pounds that can be carried by the tire.

Maximum Permissible Inflation Pressure

This number is the greatest amount of air pressure that should ever be put in the tire under normal driving conditions.

1.5.9.2. UTQGS Information

Treadwear Number

This number indicates the tire's wear rate. The higher the treadwear number is, the longer it should take for the tread to wear down. For example, a tire graded 400 should last twice as long as a tire graded 200.

Traction Letter

This letter indicates a tire's ability to stop on wet pavement. A higher graded tire should allow you to stop your car on wet roads in a shorter distance than a tire with a lower grade. Traction is graded from highest to lowest as "AA", "A", "B", and "C".

Temperature Letter

This letter indicates a tire's resistance to heat. The temperature grade is for a tire that is inflated properly and not overloaded. Excessive speed, underinflation or excessive loading, either separately or in combination, can cause heat build-up and possible tire failure. From highest to lowest, a tire's resistance to heat is graded as "A", "B", or "C".

1.5.9.3. Additional Information on Light Truck Tires

Please refer to the following diagram.

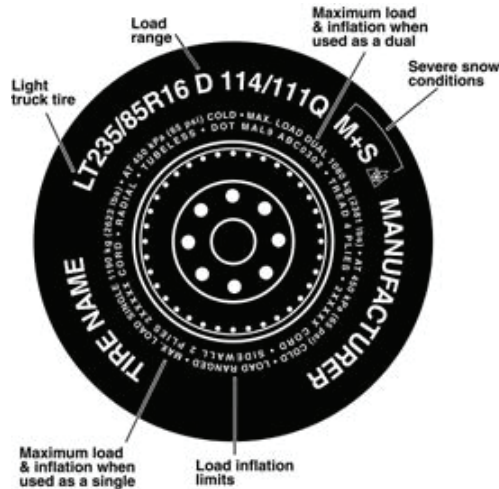

Tires for light trucks have other markings besides those found on the sidewalls of passenger tires.

LT

The "LT" indicates the tire is for light trucks or trailers.

ST

An "ST" is an indication the tire is for trailer use only.

Max. Load Dual kg (lbs) at kPa (psi) Cold

This information indicates the maximum load and tire pressure when the tire is used as a dual, that is, when four tires are put on each rear axle (a total of six or more tires on the vehicle).

Max. Load Single kg (lbs) at kPa (psi) Cold

This information indicates the maximum load and tire pressure when the tire is used as a single.

Load Range

This information identifies the tire's load-carrying capabilities and its inflation limits.

1.6. TIRE SAFETY TIPS

Preventing Tire Damage

- Slow down if you have to go over a pothole or other object in the road.
- Do not run over curbs or other foreign objects in the roadway, and try not to strike the curb when parking.

Tire Safety Checklist

- Check tire pressure regularly (at least once a month), including the spare.
- Inspect tires for uneven wear patterns on the tread, cracks, foreign objects, or other signs of wear or trauma.
- Remove bits of glass and foreign objects wedged in the tread.
- Make sure your tire valves have valve caps.
- Check tire pressure before going on a long trip.
- Do not overload your vehicle. Check the Tire Information and Loading Placard or User's Manual for the maximum recommended load for the vehicle.

