

Allmand™

Brighter. Warmer. Safer.

Portable
Industrial
Heaters

Portable
Light Towers

Portable
Light Stands

Solar Flashing
Arrow Boards

en Parts Manual
MAXI-POWER™ 150

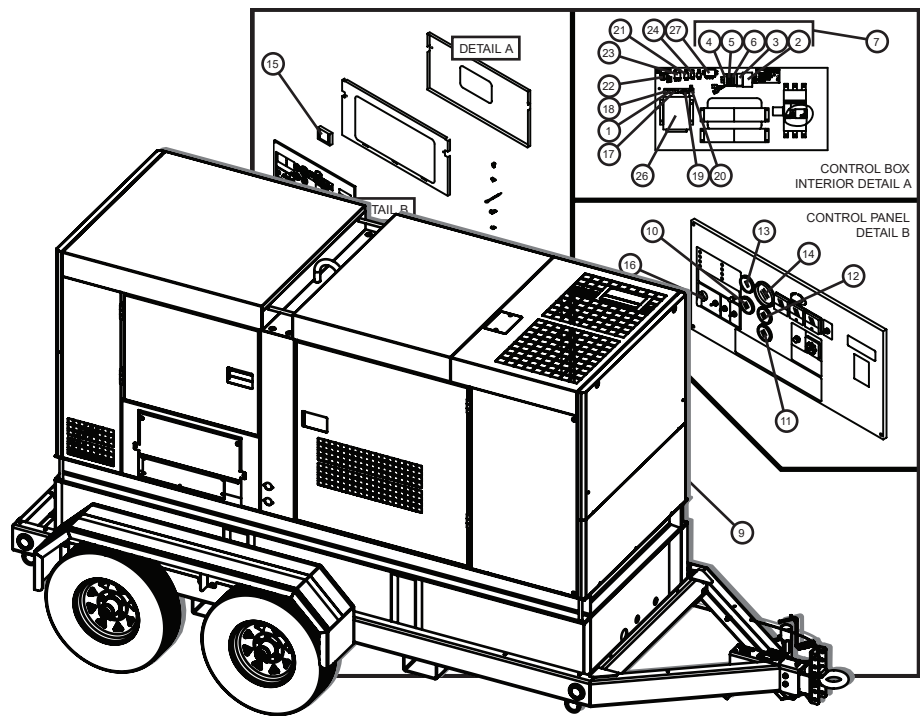

Copyright © 2021 Briggs & Stratton
Milwaukee, WI, USA. All rights reserved.

Part No.: 112122
Revision: C
Serial No.: 27-000001 to 27-000099

LIGHT TOWER APP



Reliability, Performance, and Integrity Since 1938

www.allmand.com

TABLE OF CONTENTS

1.0 TRAILER PARTS GROUP

Trailer Axle, Jack, and Coupler	(1.1)
Trailer Base Parts	(1.2)
Step Plate	(1.3)

2.0 ENGINE AND GENERATOR GROUP

Engine Cooling and Exhaust Group	(2.1)
Generator and Engine Mounting Group	(2.2)
Engine Air Intake Group	(2.3)
Fuel Tank and Filters Group	(2.4)

3.0 ELECTRICAL GROUP

Engine Electrical Group	(3.1)
Generator Electrical Group	(3.2)
Tail Lights and Tail Light Harness	(3.3)
Cam Lock Group	(3.4)
Arctic Package	(3.5)

4.0 DECALS

Left and Front Side Branding Decals	(4.1)
Right and Rear Side Branding Decals	(4.2)
Cam Lock and Arctic Package Decals	(4.3)

Maxi-Power 150

PAGE LEFT BLANK
INTENTIONALLY

1.1 - Trailer Axle, Jack, and Coupler

SN 27-000001 to 27-000099

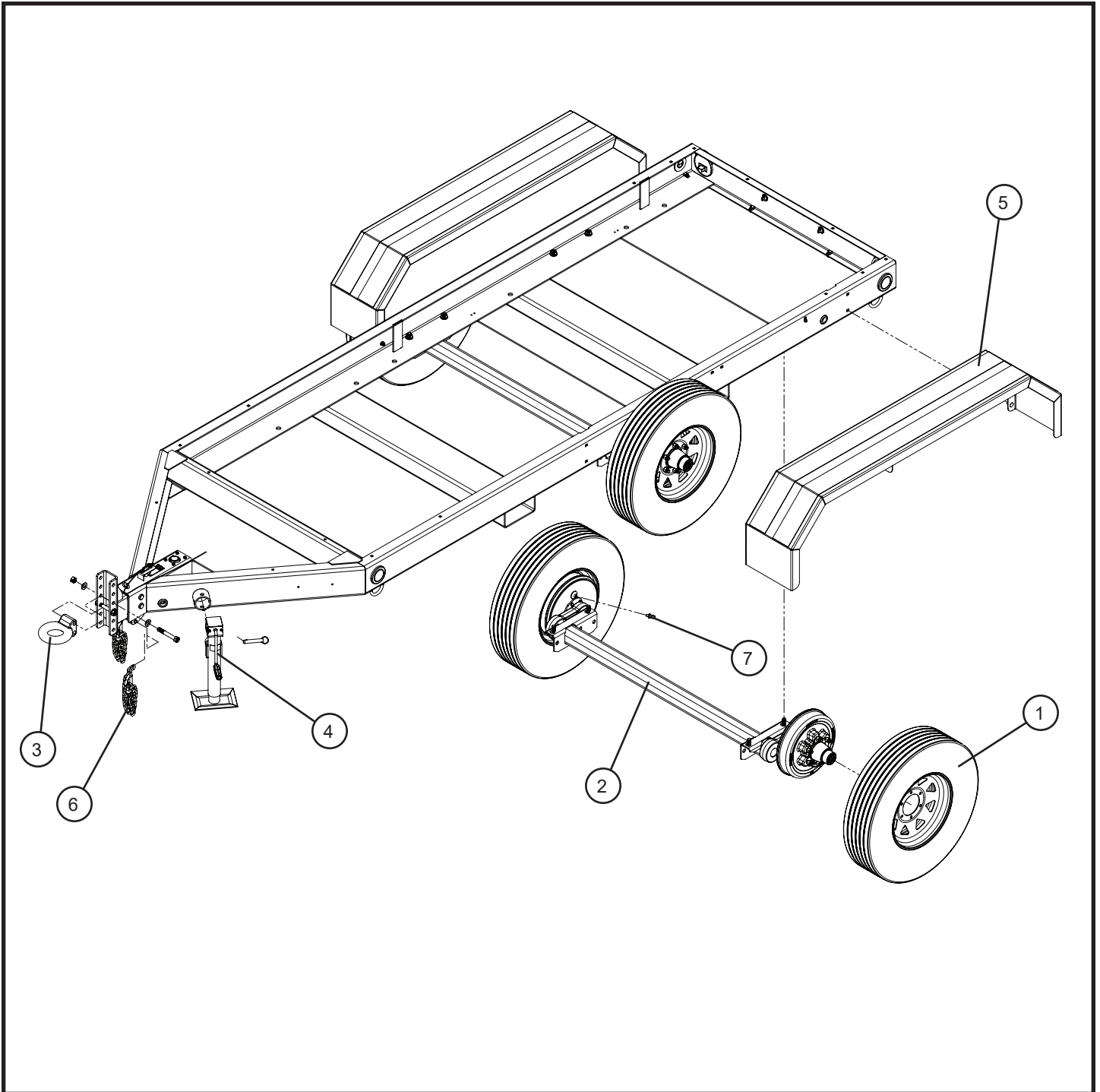

Maxi-Power 150

1.1 - Trailer Axle, Jack, and Coupler

SN 27-000001 to 27-000099

Item	Allmand No.	Hokuetsu No.	Part Description	Qty.
1	113445	n/a	WHEEL W/ TIRE ASSEMBLY, 2600 LB CAPACITY	4
2	113448	n/a	5.2K TORSION AXLE (INCLUDES HARDWARE)	2
3	113449	n/a	3" CHANNEL MOUNT TOW RING	1
4	113451	n/a	TUBE MOUNT 7K TOP WIND JACK	1
5	113457	n/a	MP 125/150 FENDER (INCLUDES HARDWARE AND GRIP TAPE)	2
	113460	n/a	MP 125/150 FENDER GRIP TAPE KIT	2
6	113464	n/a	MP 125/150 SAFETY TOW CHAINS	2
7	113467	n/a	MP 125/150 RUBBER BRAKE HOSE W/ END FITTINGS (NOT COMPLETELY SHOWN)	1
NS	113461	n/a	MASTER CYLINDER BRAKE ACTUATOR	1
NS	113483	n/a	MP 125/150 STEEL BRAKE LINE KIT	1

1.2 - Trailer Base Parts

SN 27-000001 to 27-000099

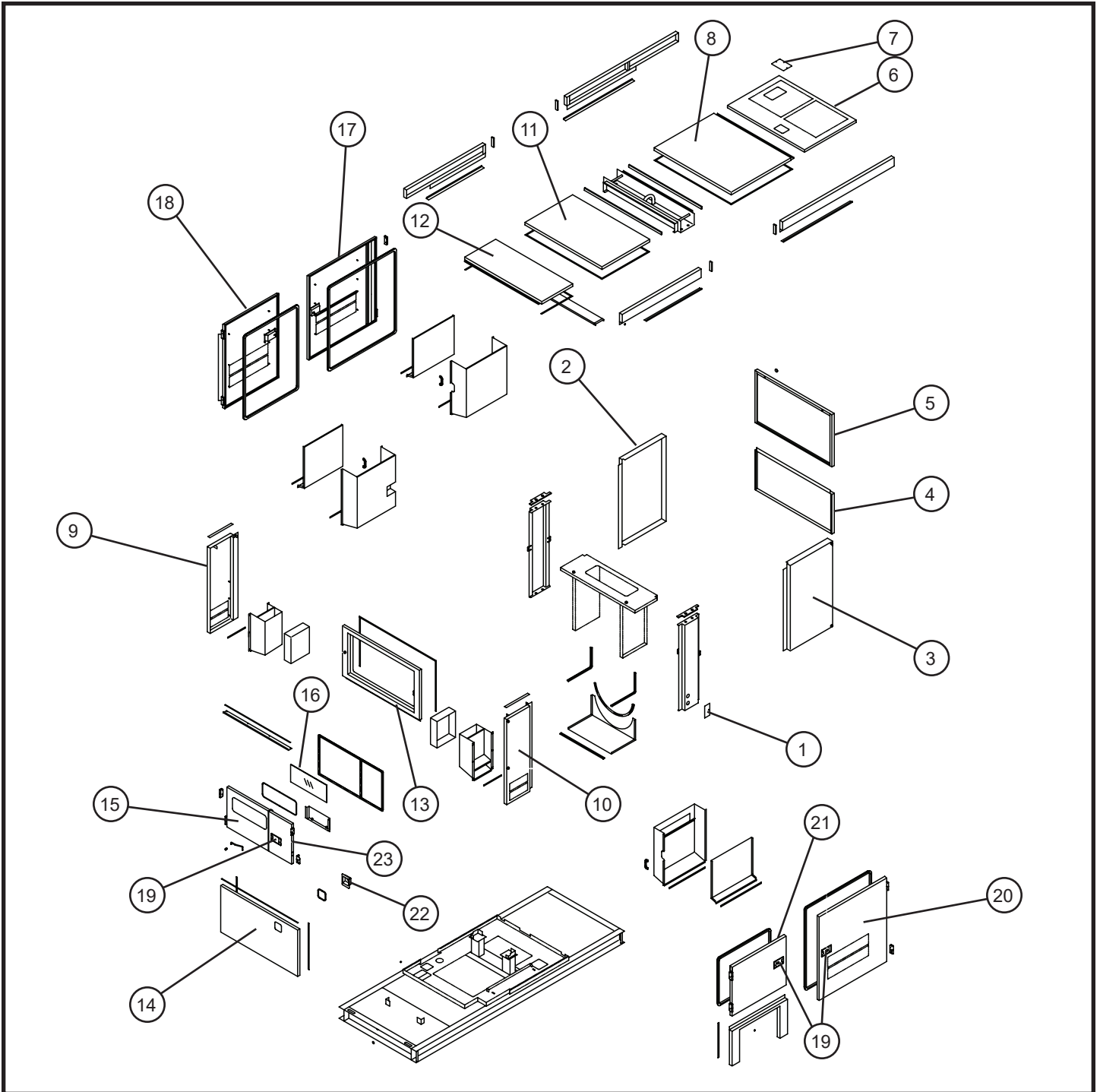

Maxi-Power 150

1.2 - Trailer Base Parts

SN 27-000001 to 27-000099

Item	Allmand No.	Hokuetsu No.	Part Description	Qty.
1	110538	52350 41920	COVER	1
2	112088	52100 54120	LEFT SIDE FRONT COVER MP 150	1
3	112090	52100 54220	RIGHT SIDE FRONT COVER MP 150	1
4	112092	52830 38400	FRONT LOWER COVER MP 150	1
5	112094	52830 38500	FRONT UPPER COVER MP 150	1
6	112096	52300 95910	TOP FRONTAL COVER MP 150	1
7	110472	52350 89010	TOP FRONT COVER	1
8	112098	52300 95810	TOP MID-FRONTAL COVER MP 150	1
9	112100	52100 54021	LEFT SIDE REAR COVER MP 150	1
10	112102	52100 53921	RIGHT SIDE REAR COVER MP 150	1
11	112104	52300 96110	TOP MID-REAR COVER MP 150	1
12	112105	52300 97210	TOP REAR COVER	1
13	112107	52100 54320	REAR UPPER COVER MP 150	1
14	n/a	52230 43300	REAR LOWER COVER MP 150	1
15	112109	52450 89221	REAR LEFT DOOR	1
16	112110	52416 24400	WINDOW GLASS	1
17	112112	52450 89520	LEFT SIDE FRONT DOOR MP 150	1
18	112114	52450 89420	LEFT SIDE REAR DOOR MP 150	1
19	110499	52710 03601	LATCH ASSEMBLY	5
20	112116	52450 89320	RIGHT SIDE FRONT DOOR MP 150	1
21	112118	52450 89120	RIGHT SIDE REAR DOOR MP 150	1
22	110681	52230 44800	EMERGENCY STOP COVER	1
23	112119	52450 37530	REAR RIGHT DOOR	1

1.3 - Step Plate

SN 27-000001 to 27-000099

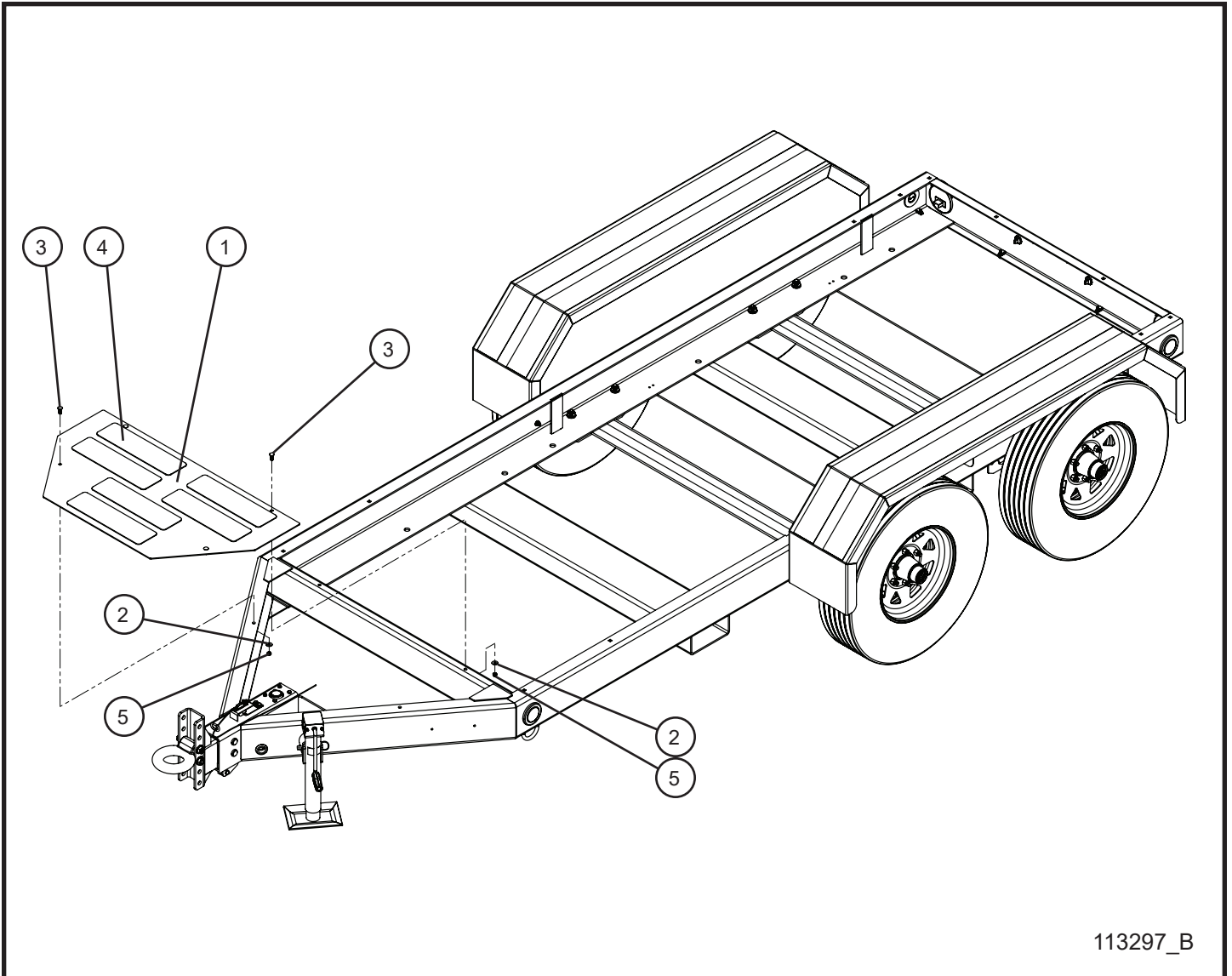

Maxi-Power 150

1.3 - Step Plate

SN 27-000001 to 27-000099

Item	Allmand No.	Hokuetsu No.	Part Description	Qty.
1	113258P	n/a	STEP PLATE MAXI-POWER 125-150	1
2	047010	n/a	5/16 FLAT WASHER	4
3	053020	n/a	5/16-18 x 1 CARRIAGE BOLT	4
4	062006	n/a	DIE CUT ANTI SKID TAPE	6
5	044033	n/a	5/16-18 NYLOCK HEX NUT	4

2.1 - Engine Cooling and Exhaust Group

SN 27-000001 to 27-000099

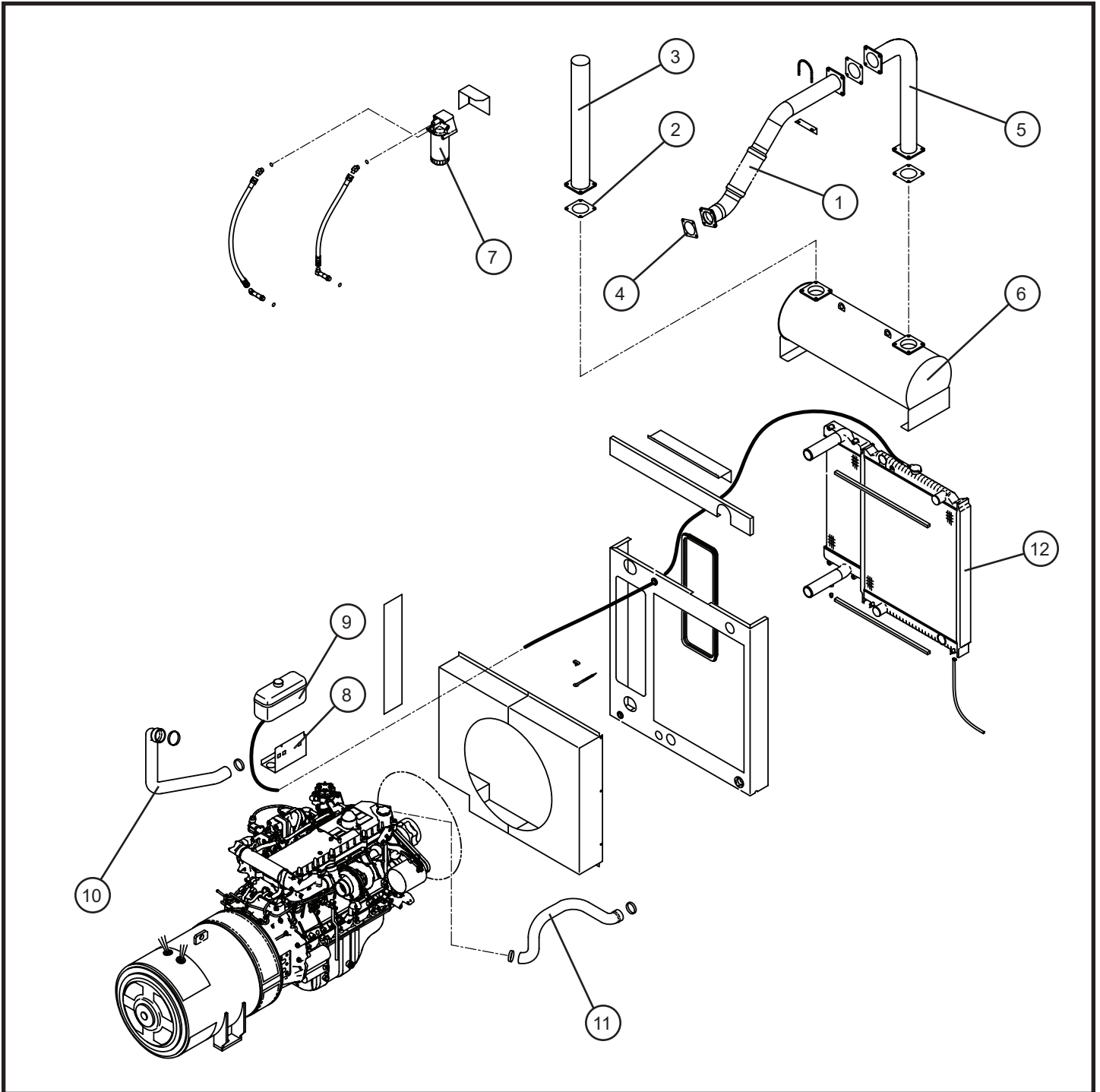

Maxi-Power 150

2.1 - Engine Cooling and Exhaust Group

SN 27-000001 to 27-000099

Item	Allmand No.	Hokuetsu No.	Part Description	Qty.
1	110990	42310 06110	PIPE, EXHAUST	1
2	110989	42323 04500	GASKET	1
3	110987	42310 92200	PIPE, EXHAUST	1
	110988	42310 90000	PIPE, EXHAUST	1
4	110983	42324 14300	GASKET	1
	110984	42324 14100	GASKET	1
5	110982	42310 92100	PIPE, EXHAUST	1
6	110981	42100 78200	EXHAUST MUFFLER	1
7	110979	41290 00800	FILTER ASS'Y, ENG. OIL	1
8	110978	38860 28600	BRACKET	1
9	110977	38590 00300	RESERVE TANK ASS'Y	1
10	110975	38524 67500	HOSE	1
	110976	38524 66501	HOSE	1
11	110973	38524 67400	HOSE	1
	110974	38524 66400	HOSE	1
12	110971	38100 42900	RADIATOR	1
	110970	38100 41100	RADIATOR	1

2.2 - Generator and Engine Mounting Group

SN 27-000001 to 27-000099

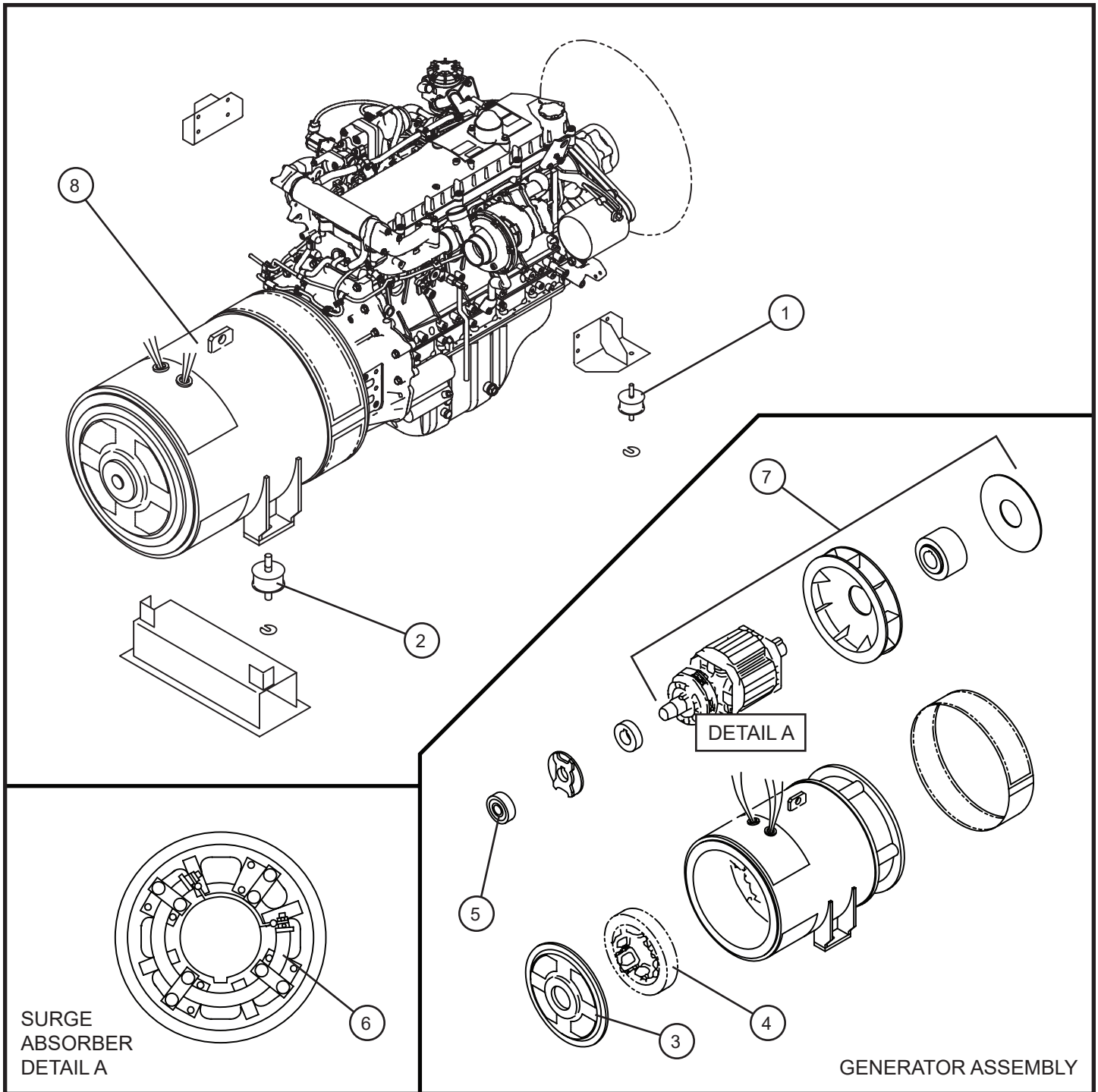

Maxi-Power 150

2.2 - Generator and Engine Mounting Group

SN 27-000001 to 27-000099

Item	Allmand No.	Hokuetsu No.	Part Description	Qty.
1	111007	31130 09600	VIBRATION ISOLATOR ASSEMBLY	2
2	111006	31130 09200	VIBRATION ISOLATOR ASSEMBLY	2
	111005	31130 09100	VIBRATION ISOLATOR ASSEMBLY	2
3	111004	25310 09100	CASING	1
4	111001	25700 08001	EX. STATOR ASSEMBLY	1
	111002	25700 07901	EX. STATOR ASSEMBLY	1
	111003	25700 06601	EX. STATOR ASSEMBLY	1
5	111000	21472 09700	BEARING (6314XZZ)	1
	110999	21472 00100	BEARING (6311ZZCM)	1
6	110997	25650 02100	SURGE ABSORBER	1
	110998	25650 01601	SURGE ABSORBER	1
7	110994	25100 09501	A.C.G. ROTOR ASSEMBLY	1
	110995	25100 09401	A.C.G. ROTOR ASSEMBLY	1
	110996	25100 08001	A.C.G. ROTOR ASSEMBLY	1
8	110992	20003 61500	GENERATOR	1
	110991	20003 61400	GENERATOR	1
	110993	20003 59201	GENERATOR	1

2.3 - Engine Air Intake Group

SN 27-000001 to 27-000099

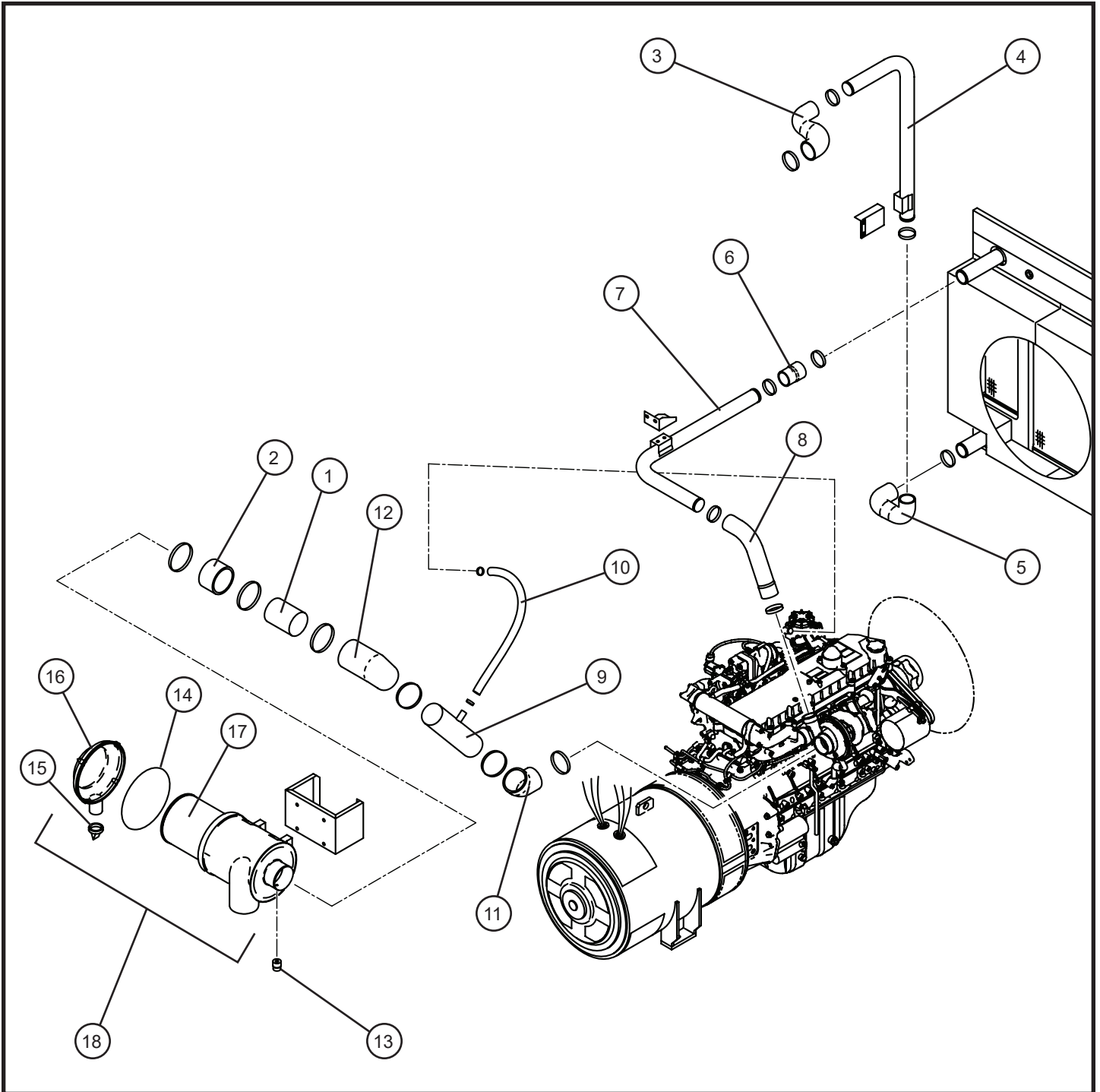

Maxi-Power 150

2.3 - Engine Air Intake Group

SN 27-000001 to 27-000099

Item	Allmand No.	Hokuetsu No.	Part Description	Qty.
1	110972	32320 68100	PIPE	1
2	111037	32331 73900	HOSE	1
3	111035	32331 72501	HOSE	1
	111036	32331 70901	HOSE	1
4	111033	32320 67500	PIPE	1
	111034	32320 66900	PIPE	1
5	111032	32331 72701	HOSE	1
	111031	32331 72400	HOSE	1
6	111030	32332 08102	HOSE	1
7	111028	32320 67400	PIPE	1
	111029	32320 66800	PIPE	1
8	111026	32331 72301	HOSE	1
	111027	32331 70701	HOSE	1
9	111024	32320 67600	PIPE, INTAKE	1
	111025	32320 67300	PIPE, INTAKE	1
10	111022	03591 25120	HOSE	1
	111023	03591 25110	HOSE	1
11	111021	32331 72601	HOSE	1
	111020	32331 72201	HOSE	1
12	111018	32331 72101	HOSE	1
	111019	32331 60500	HOSE	1
13	111017	32148 03000	FILTER, SERVICE INDICATOR	1
14	111015	32147 03400	O-RING	1
	111016	32147 03100	O-RING	1
15	111014	32151 01600	VACUATOR VALVE	1
16	111012	32142 11200	CUP	1
	111013	32142 10700	CUP	1
17	111010	32143 16200	ELEMENT	1
	111011	32143 12500	ELEMENT	1
18	111008	32100 43900	AIR FILTER ASSEMBLY	1
	111009	32100 42000	AIR FILTER ASSEMBLY	1

2.4 - Fuel Tank and Filters Group

SN 27-000001 to 27-000099

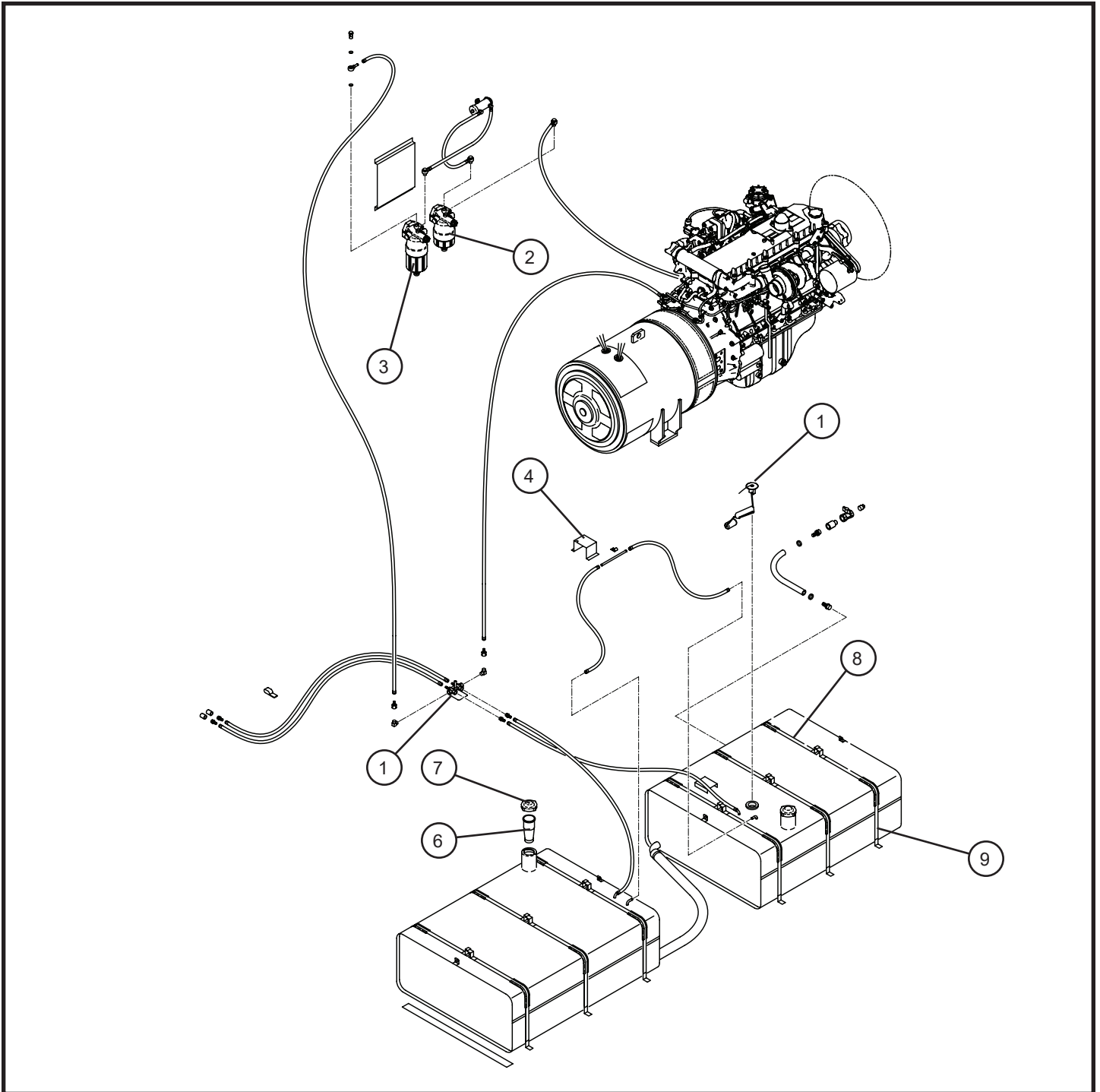

Maxi-Power 150

2.4 - Fuel Tank and Filters Group

SN 27-000001 to 27-000099

Item	Allmand No.	Hokuetsu No.	Part Description	Qty.
1	110968	35483 10101	STOP VALVE	1
2	110964	43540 07700	FILTER ASSEMBLY	1
	110965	43543 01000	FILTER	1
3	110962	43540 07600	FILTER ASSEMBLY	1
4	110961	43570 07900	BRACKET	1
5	110960	36159 00600	SENDING UNIT	1
6	110959	43210 01301	STRAINER	1
7	110958	43220 01300	CAP, FUEL TANK	1
8	110957	43310 27100	BELT	6
9	110956	43310 27000	BELT	6

3.1 - Engine Electrical Group

SN 27-000001 to 27-000099

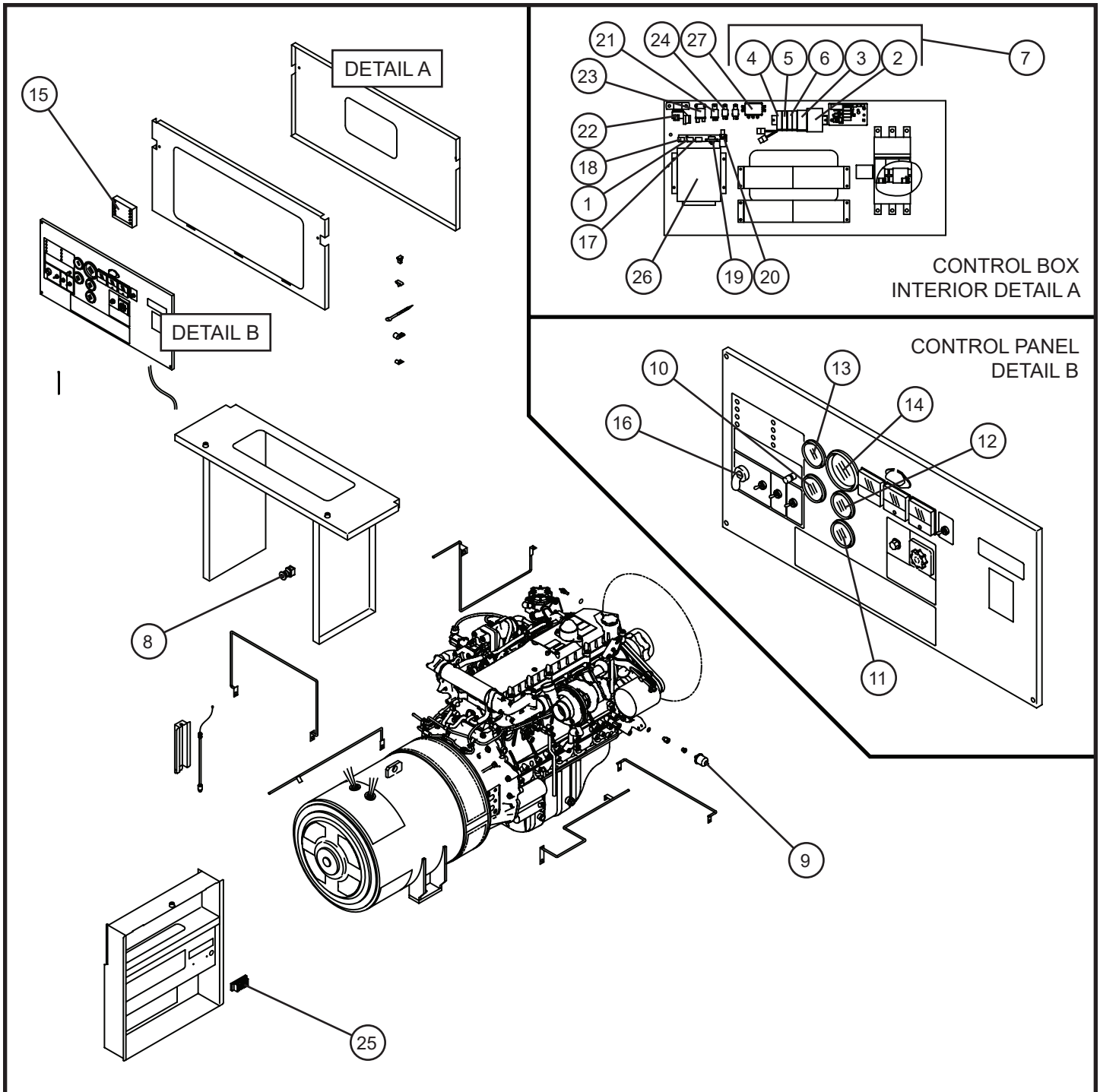

Maxi-Power 150

3.1 - Engine Electrical Group

SN 27-000001 to 27-000099

Item	Allmand No.	Hokuetsu No.	Part Description	Qty.
1	110660	44470 01700	FUSE BOX	1
	110715	44470 01600	FUSE BOX	1
2	110953	46879 45800	CONTROLLER COMPLETE	1
3	110952	46872 01300	DC POWER SUPPLY	1
4	110951	46177 08500	RELAY (AC220V)	1
5	110950	46177 08700	RELAY (DC24V)	1
	110949	46177 08400	RELAY (DC12V)	1
6	110948	46177 08600	RELAY (DC24V)	1
	110947	46177 08300	RELAY (DC12V)	1
7	110945	46760 46210	CONTROL PANEL	1
	110946	46760 43810	CONTROL PANEL	1
8	110944	44336 03001	BUTTON SWITCH	1
9	110943	44365 00300	OIL PRESSURE SENDER	1
10	110942	46154 15300	AMMETER (12V)	1
11	110941	36145 06700	THERMOMETER, WATER (24V)	1
	110940	36145 06500	THERMOMETER, WATER (12V)	1
12	110939	36143 03800	GAUGE, OIL PRESSURE (24V)	1
	110938	36143 03600	GAUGE, OIL PRESSURE (12V)	1
13	110937	36158 00601	GAUGE, FUEL (24V)	1
	110936	36158 00500	GAUGE, FUEL (12V)	1
14	110935	36146 06200	TACHOMETER (24V)	1
	110934	36146 05901	TACHOMETER (12V)	1
15	110932	46870 47901	CONTROLLER (EMERGENCYLAMP)	1
	110933	46870 47401	CONTROLLER (EMERGENCYLAMP)	1
16	110931	44322 02800	STARTER SWITCH	1
17	110658	44470 01900	FUSE BOX	1
18	110715	44470 01600	FUSE BOX	1
19	110928	44328 21500	PRESSURE SWITCH	1
20	110927	44364 06600	THERMO SENSOR	1
21	110926	44346 07500	RELAY(FUEL PUMP)	1
22	110923	44346 15900	RELAY(STARTER)	1
	110924	44346 15600	RELAY(STARTER)	1
23	110921	44346 15700	RELAY(GLOW)	1
	110922	44346 15500	RELAY(GLOW)	1
24	110697	44324 08500	RELAY(STARTER CUT)	1
25	110656	44311 65600	TERMINAL PLATE	1
26	110915	44390 02400	CONTROLLER	1
	110916	44390 02300	CONTROLLER	1
27	110913	44346 13200	RELAY(CHARGE)	1
	110914	44335 01100	MAGNETIC SWITCH	1

3.2 - Generator Electrical Group

SN 27-000001 to 27-000099

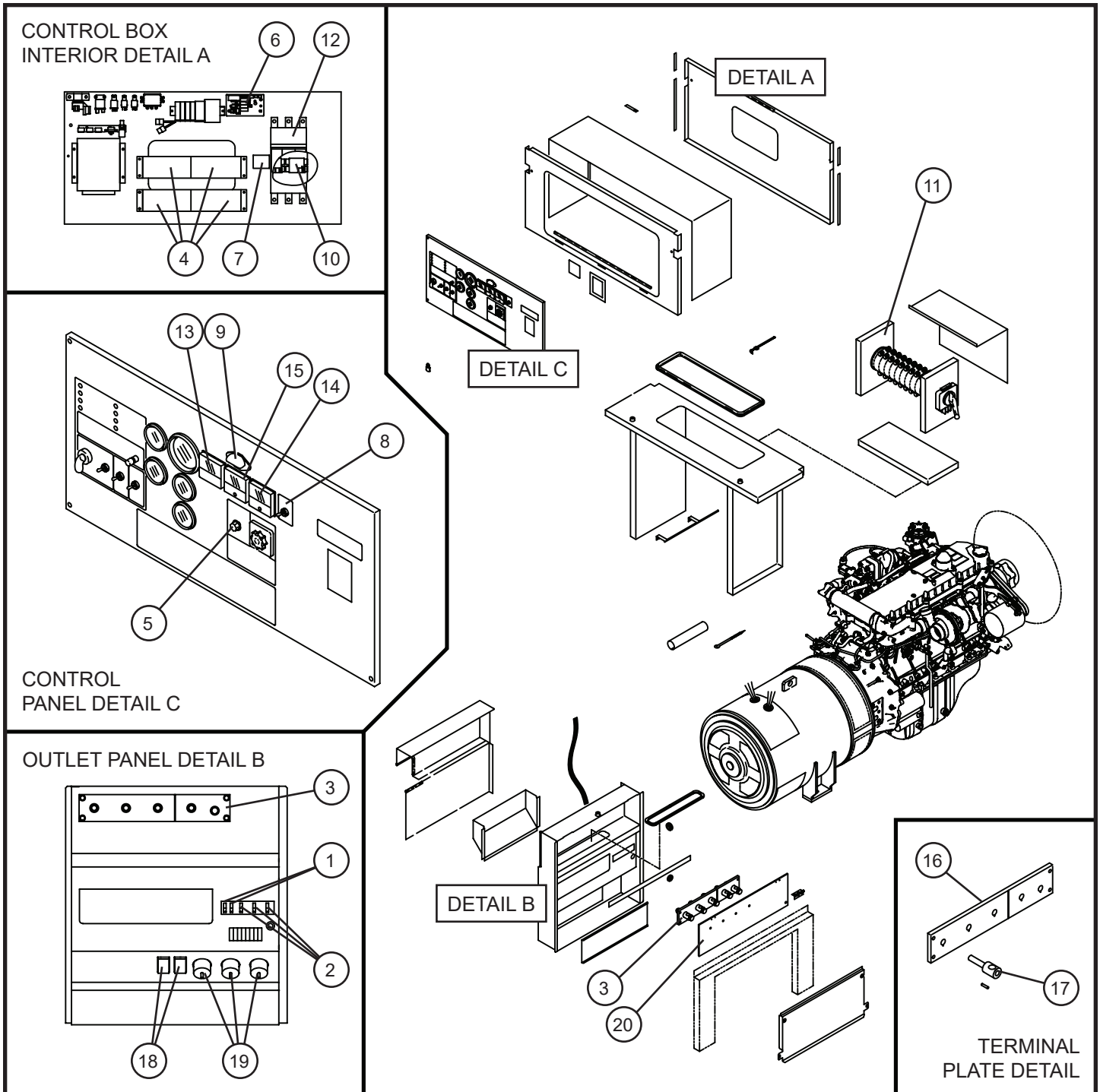

Maxi-Power 150

3.2 - Generator Electrical Group

SN 27-000001 to 27-000099

Item	Allmand No.	Hokuetsu No.	Part Description	Qty.
1	110912	46120 34100	CIRCUIT BREAKER	2
	110911	46120 26800	CIRCUIT BREAKER	2
2	110910	46120 34000	CIRCUIT BREAKER	3
	110909	46120 26900	CIRCUIT BREAKER	3
3	110908	44311 56101	TERMINAL PLATE	1
4	110907	44311 58900	TERMINAL PLATE	4
	110906	44311 07600	TERMINAL PLATE	4
5	110454	46918 01401	CONTROLLER	1
6	110679	46950 02600	A.V.R ASSEMBLY	1
7	110903	46928 01500	THERMAL RELAY	1
8	110902	46167 02400	SELECT SWITCH	1
9	110448	46929 01200	ILLUMINATOR	1
	110901	46929 00600	ILLUMINATOR	1
10	110898	46923 04600	CURRENT TRANSFORMER	1
	110899	46923 04100	CURRENT TRANSFORMER	1
11	110896	46917 03200	CHANGE DEVICE, VOLTAGE	1
	110897	46917 03100	CHANGE DEVICE, VOLTAGE	1
12	110893	46120 31300	CIRCUIT BREAKER	1
	110894	46120 31200	CIRCUIT BREAKER	1
	110895	46120 30900	CIRCUIT BREAKER	1
13	110892	46911 01200	FREQUENCY METER	1
14	110890	46154 13700	AMMETER (AC)	1
	110891	46154 12500	AMMETER (AC)	1
15	110889	46153 03100	VOLTMETER (AC)	1
16	n/a	46305 09100	PLATE	1
17	n/a	46312 05100	BOLT	5
	112075	35208 04500	BOLT	5
	112076	02912 03014	NUT	5
18	110469	44312 02900	SOCKET	2
19	110468	44312 02800	SOCKET	3
20	n/a	52416 27202	WINDOW GLASS	1
	112086	52416 26900	WINDOW GLASS	1
NS	110515	02201 08020	FLANGE BOLT	16

3.3 - Tail Lights and Tail Light Harness

SN 27-000001 to 27-000099

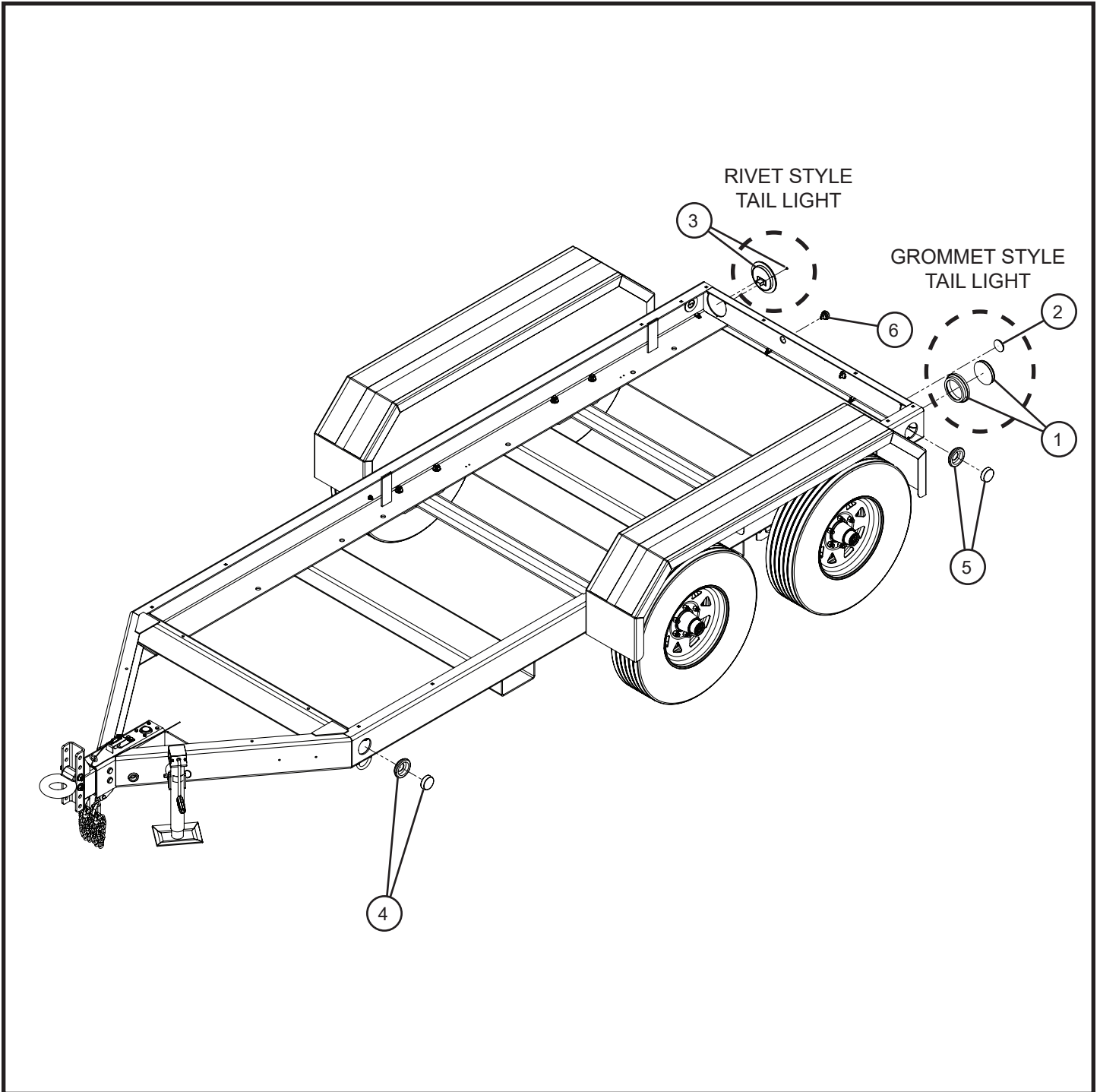

Maxi-Power 150

3.3 - Tail Lights and Tail Light Harness

SN 27-000001 to 27-000099

Item	Allmand No.	Hokuetsu No.	Part Description	Qty.
1	113438	n/a	4" TAIL LIGHT W/ GROMMET	2
2	113439	n/a	TAIL LIGHT REFLECTOR (ONLY USED W/ GROMMET TAIL LIGHTS)	2
3	113440	n/a	4" FLANGE MOUNT TAIL LIGHT W/ RIVETS	2
4	113441	n/a	2.5" AMBER SIDE MARKER/REFLECTOR W/ GROMMET	2
5	113442	n/a	2.5" RED SIDE MARKER/REFLECTOR W/ GROMMET	2
6	113443	n/a	1.25" LICENSE PLATE LED LIGHT	2
NS	113454	n/a	TAIL LIGHT WIRE HARNESS MP 125/150	1

3.4 - Maxi-Power 150 Cam Lock Group (1 of 2)

SN 27-000001 to 27-000099

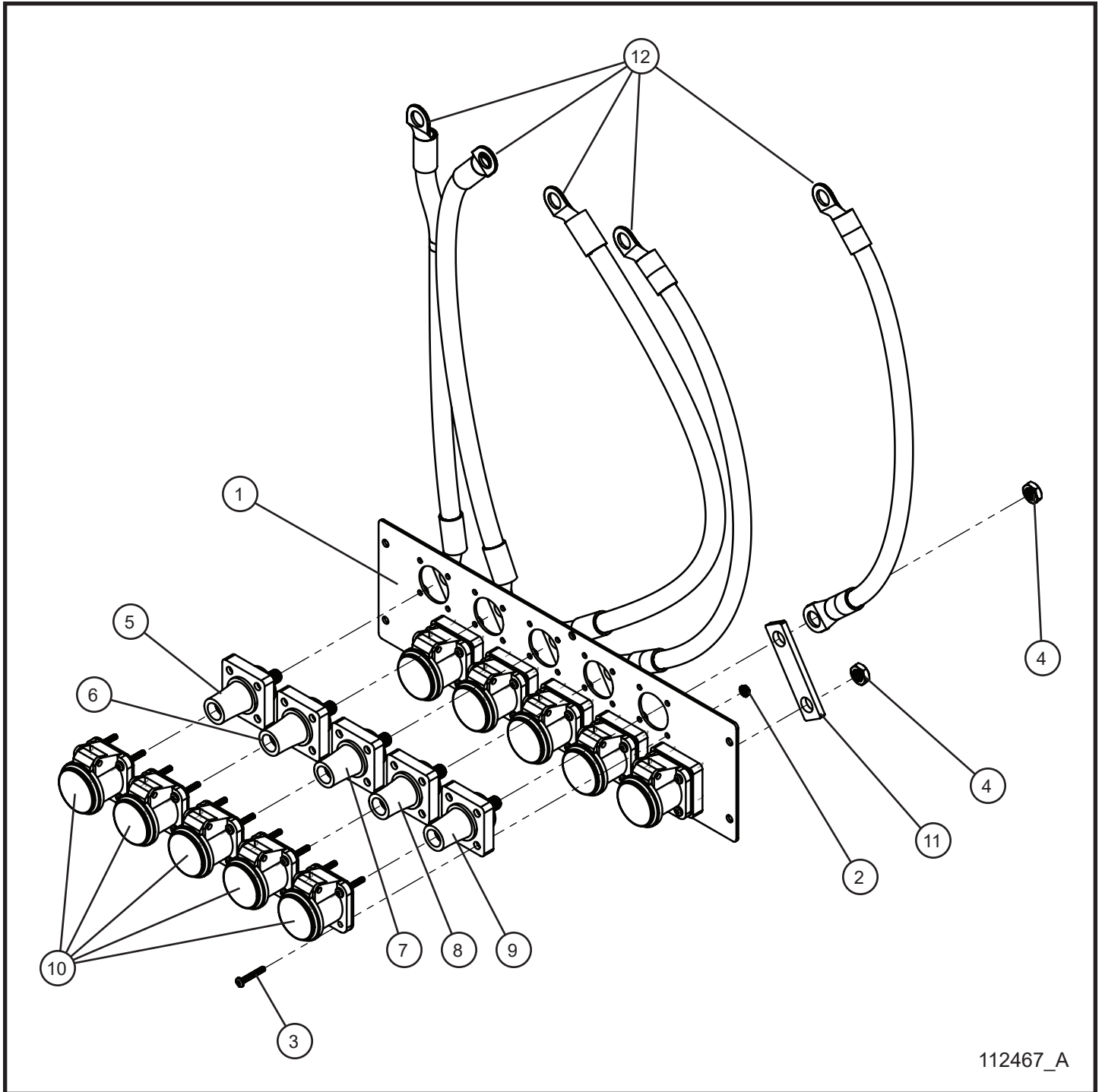

112467_A

Maxi-Power 150

3.4 - Maxi-Power 150 Cam Lock Group (1 of 2)

SN 27-000001 to 27-000099

Item	Allmand No.	Hokuetsu No.	Part Description	Qty.
1	112468P	n/a	DUAL CAM LOCK MOUNT PLATE	1
2	044016	n/a	#10-24 KEPS HEX NUT	40
3	041035	n/a	#10-24 x 1-1/4 PHILLIPS MACHINE SCREW	40
4	100643	n/a	1/2-13 NYLOCK JAM NUT	10
5	113242	n/a	CAM LOCK BLACK FEMALE 90° 600V 400A	2
6	113243	n/a	CAM LOCK RED FEMALE 90° 600V 400A	2
7	113244	n/a	CAM LOCK BLUE FEMALE 90° 600V 400A	2
8	113245	n/a	CAM LOCK WHITE FEMALE 90° 600V 400A	2
9	113246	n/a	CAM LOCK GREEN FEMALE 90° 600V 400A	2
10	112424	n/a	CAM LOCK CLEAR COVER 90°	10
11	112479	n/a	CAM LOCK DUAL BUS BAR	5
12	112556	n/a	4/0 CABLE KIT CAM LOCK MAXI-POWER 150	1
NS	112421	n/a	DUAL CAM LOCK 4/0 CABLE SCHEMATIC	1

*NS - NOT SHOWN

3.4 - Maxi-Power 150 Cam Lock Group (2 of 2)

SN 27-000001 to 27-000099

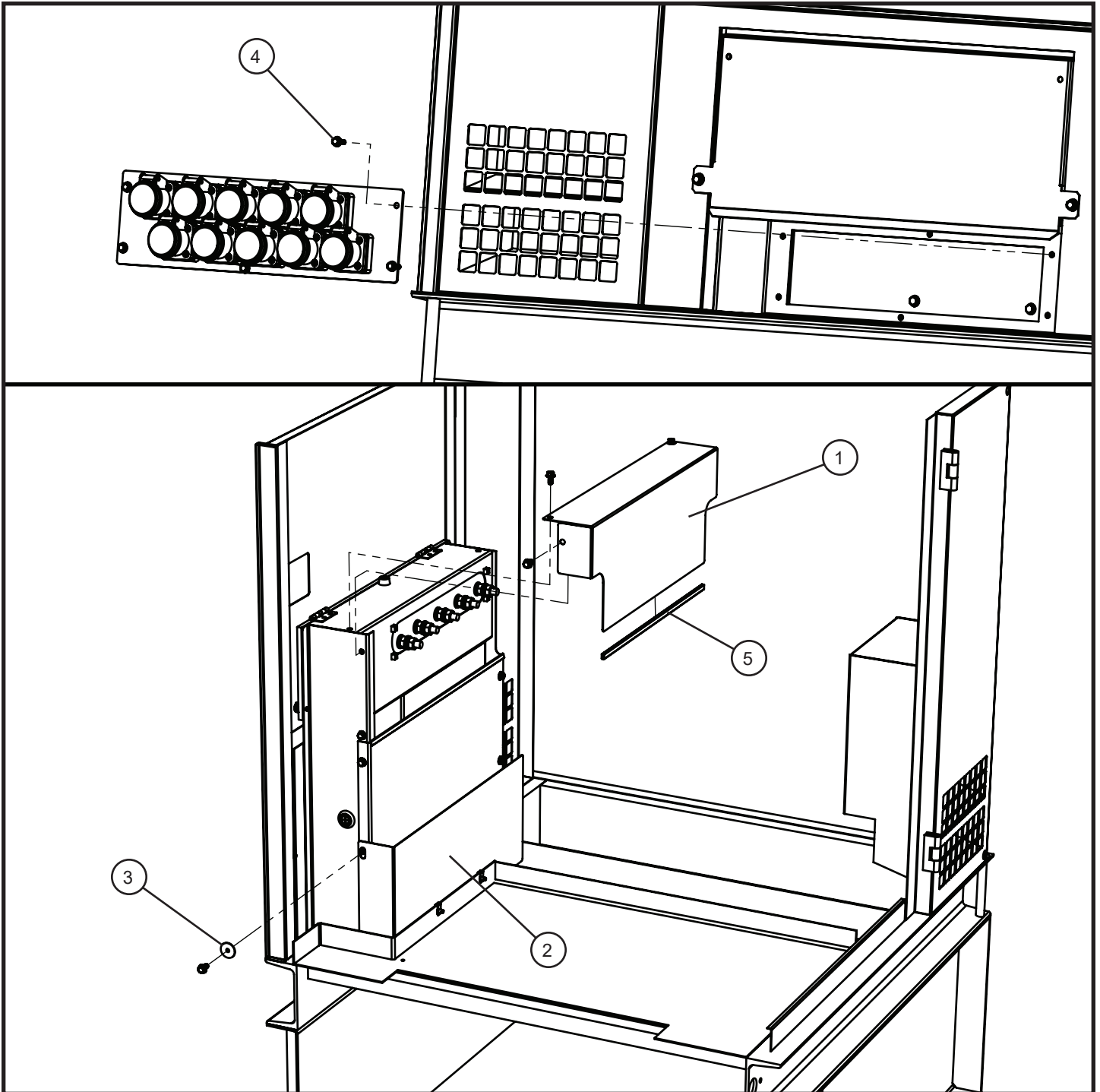

Maxi-Power 150

3.4 - Maxi-Power 150 Cam Lock Group (2 of 2)

SN 27-000001 to 27-000099

Item	Allmand No.	Hokuetsu No.	Part Description	Qty.
1	112518P	n/a	CAM LOCK UPPER SHIELD	1
2	112465P	n/a	CAM LOCK SHIELD MAXI-POWER 150	1
3	047007	n/a	1/4 x 1-1/4 x .056 FENDER WASHER	1
4	055001	n/a	M6-1.0 x 20 HEX HEAD FLANGE BOLT	6
5	030053	n/a	5/64 x 7/16 x 19.75 TRIM LOCK	1
NS	047009	n/a	1/4 FLAT WASHER	2
NS	046010	n/a	1/4-20 x 3/4 HEX HEAD BOLT	2
NS	044106	n/a	1/4-20 EXTRUDED U NUT	2

*NS - NOT SHOWN

3.5 - Maxi-Power 150 Arctic Package (1 of 2)

SN 27-000001 to 27-000099

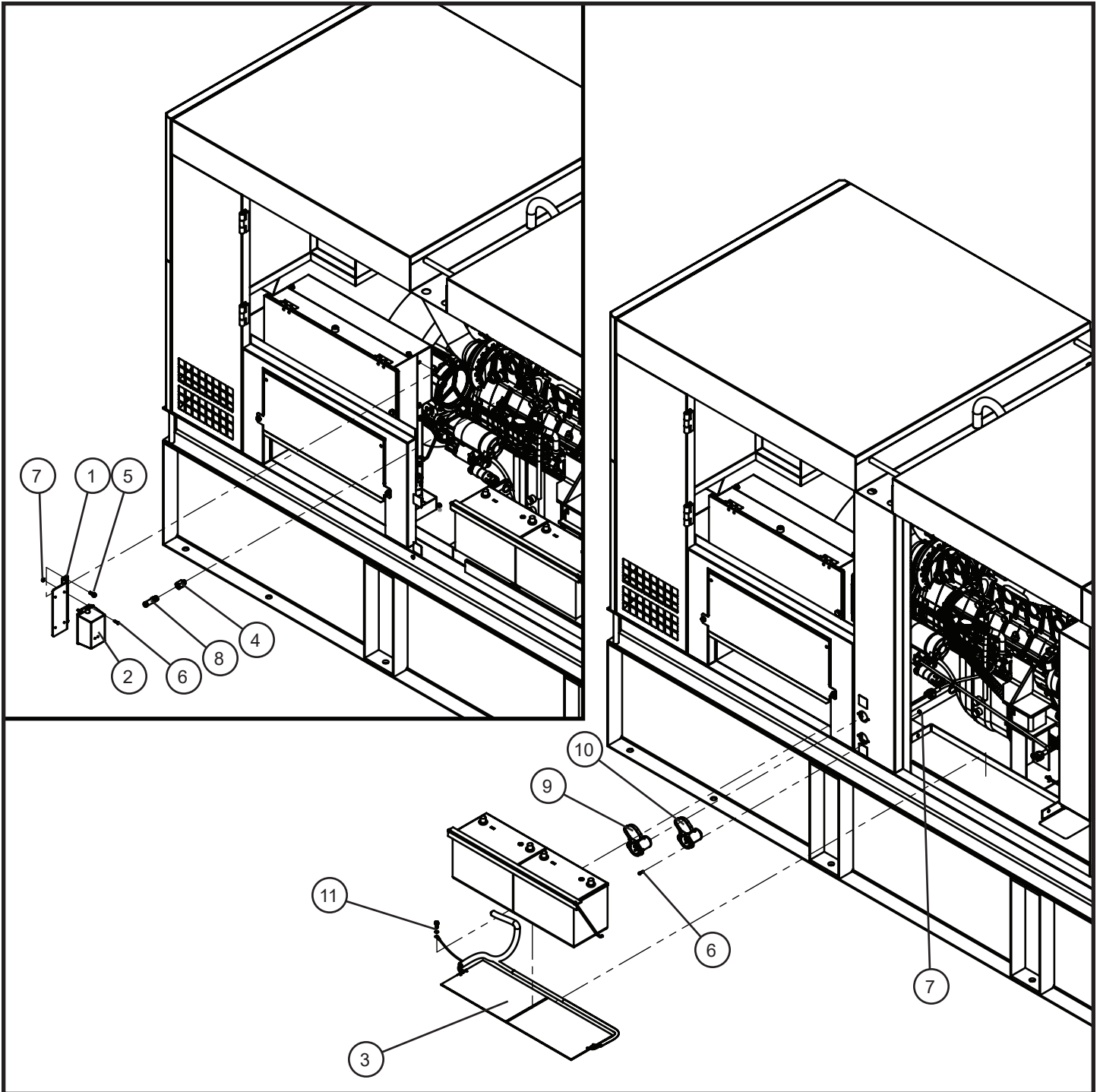

Maxi-Power 150

3.5 - Maxi-Power 150 Arctic Package (1 of 2)

SN 27-000001 to 27-000099

Item	Allmand No.	Hokuetsu No.	Part Description	Qty.
1	112603P	n/a	BATTERY CHARGER MOUNT MAXI-POWER 150	1
2	112632	n/a	BATTERY CHARGER MAXI-POWER 150	1
3	112618	n/a	BATTERY HEATER MAXI-POWER 150	1
4	112540	n/a	FITTING ADAPTOR M14 x 1.5 BSPT TO 3/8" NPT	1
5	055001	n/a	M6-1.0 x 20 HEX HEAD FLANGE BOLT	2
6	041027	n/a	#10-24 x 3/4 PHILLIPS ROUND HEAD	8
7	044016	n/a	#10-24 KEPS HEX NUT	8
8	112652	n/a	FITTING HOSE BARB 3/8" NPT - 5/8" BARB	1
9	112619	n/a	RECESSED PLUG MAXI-POWER 25 & 150	1
10	112621	n/a	RECESSED PLUG MAXI-POWER 40, 45, & 150	1
11	044106	n/a	1/4-20 EXTRUDED U NUT	1
NS	112608	n/a	PLUG 3-PRONG MALE	1
NS	022202	n/a	LOOM FLEX GUARD 3/8 x 12.00	1
NS	022202	n/a	LOOM FLEX GUARD 3/8 x 22.00	1
NS	022202	n/a	LOOM FLEX GUARD 3/8 x 35.00	1
NS	022202	n/a	LOOM FLEX GUARD 3/8 x 46.00	2
NS	022207	n/a	LOOM FLEX GUARD 5/8 x 14.00	1
NS	068090	n/a	CABLE TIE 8"	18
NS	112638	n/a	ARCTIC PACKAGE SCHEMATIC	1

3.5 - Maxi-Power 150 Arctic Package (2 of 2)

SN 27-000001 to 27-000099

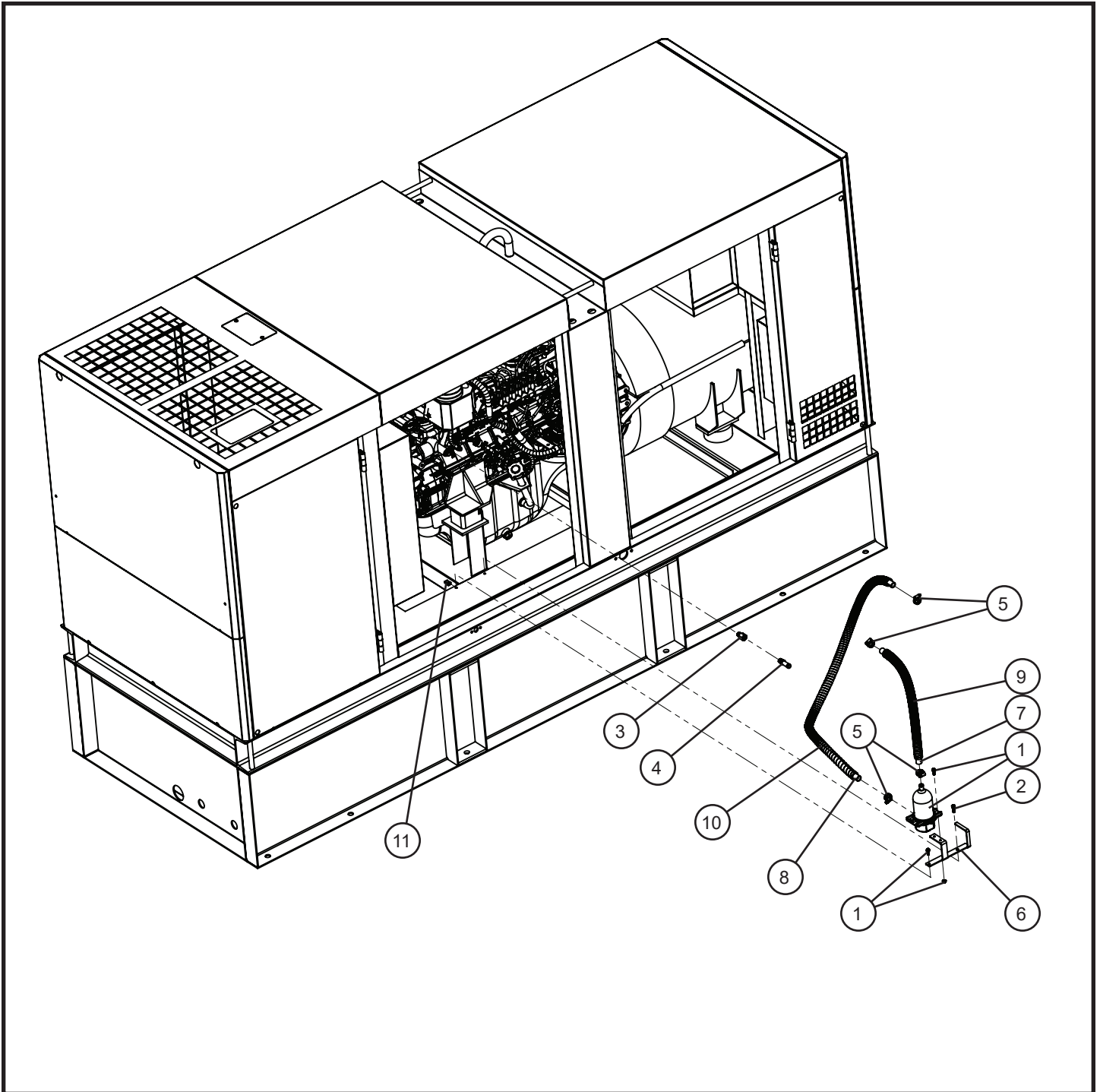

Maxi-Power 150

3.5 - Maxi-Power 150 Arctic Package (2 of 2)

SN 27-000001 to 27-000099

Item	Allmand No.	Hokuetsu No.	Part Description	Qty.
1	112601	n/a	BLOCK HEATER MAXI-POWER 150	1
2	042031	n/a	M8 x 25mm x 1.25mm HEX HEAD BOLT	1
3	104798	n/a	FITTING ADAPTOR 3/8" BSPT TO 3/8" NPT	1
4	112652	n/a	FITTING HOSE BARB 3/8" NPT - 5/8" BARB	1
5	045033	n/a	#10 HOSE CLAMP WORM GEAR	4
6	112604P	n/a	BLOCK HEATER MOUNT MAXI-POWER 150	1
7	081025	n/a	5/8 HEATER HOSE x 22.00	1
8	081025	n/a	5/8 HEATER HOSE x 49.00	1
9	022211	n/a	1.0 LOOM GUARD x 20.00	1
10	022211	n/a	1.0 LOOM GUARD x 47.00	1
11	044106	n/a	1/4-20 EXTRUDED U NUT	1

4.1 - Left and Front Side Branding Decals

SN 27-000001 to 27-000099

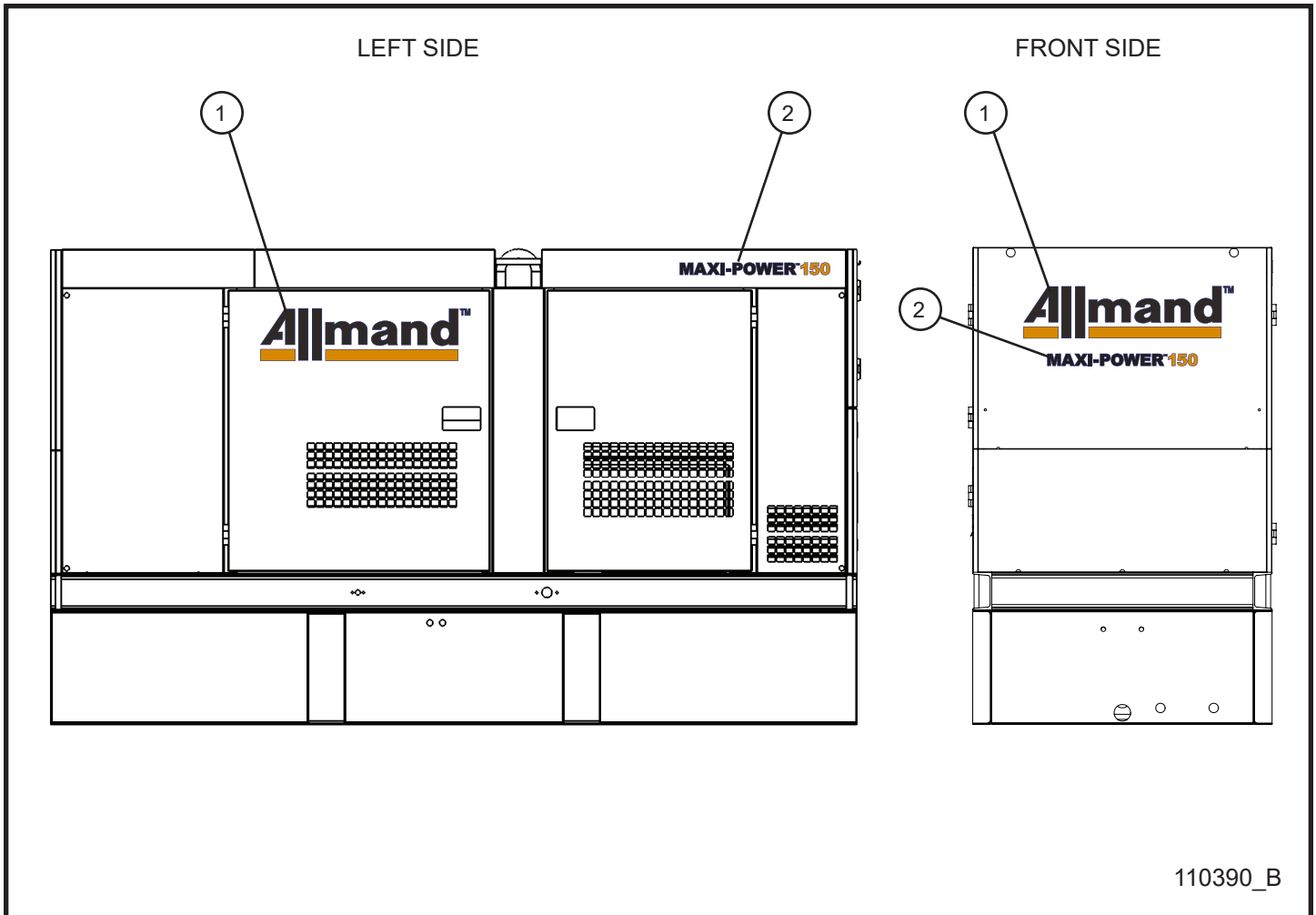

Maxi-Power 150

4.1 - Left and Front Side Branding Decals

SN 27-000001 to 27-000099

Item	Allmand No.	Hokuetsu No.	Part Description	Qty.
1	110287	n/a	LARGE BLACK ALLMAND BRANDING DECAL	2
2	109017	n/a	MAXI-POWER 150 DECAL	2

4.2 - Right and Rear Side Branding Decals

SN 27-000001 to 27-000099

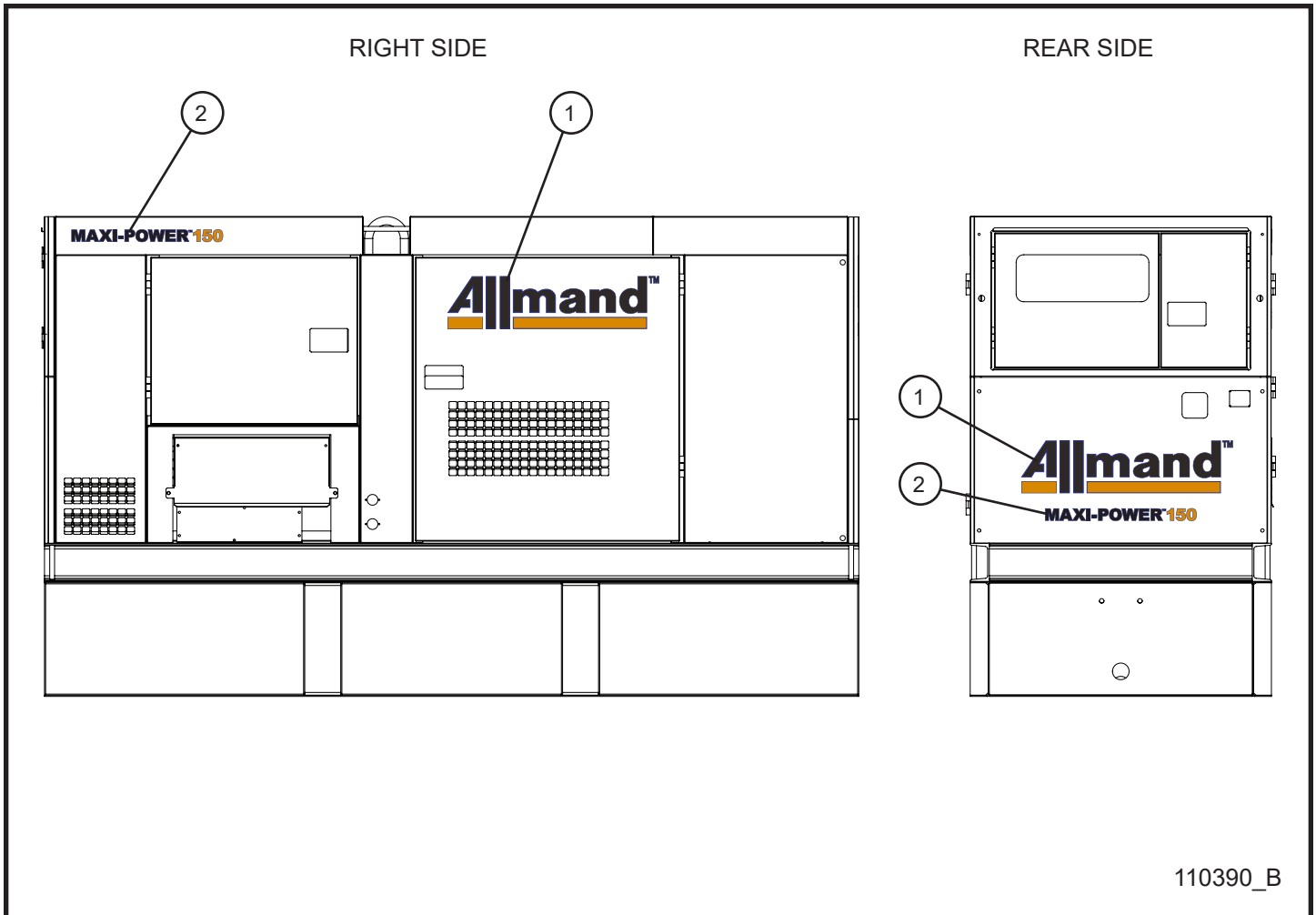

110390_B

Maxi-Power 150

4.2 - Right and Rear Side Branding Decals

SN 27-000001 to 27-000099

Item	Allmand No.	Hokuetsu No.	Part Description	Qty.
1	110287	n/a	LARGE BLACK ALLMAND BRANDING DECAL	2
2	109017	n/a	MAXI-POWER 150 DECAL	2

4.3 - Cam Lock and Arctic Package Decals

SN 27-000001 to 27-000099

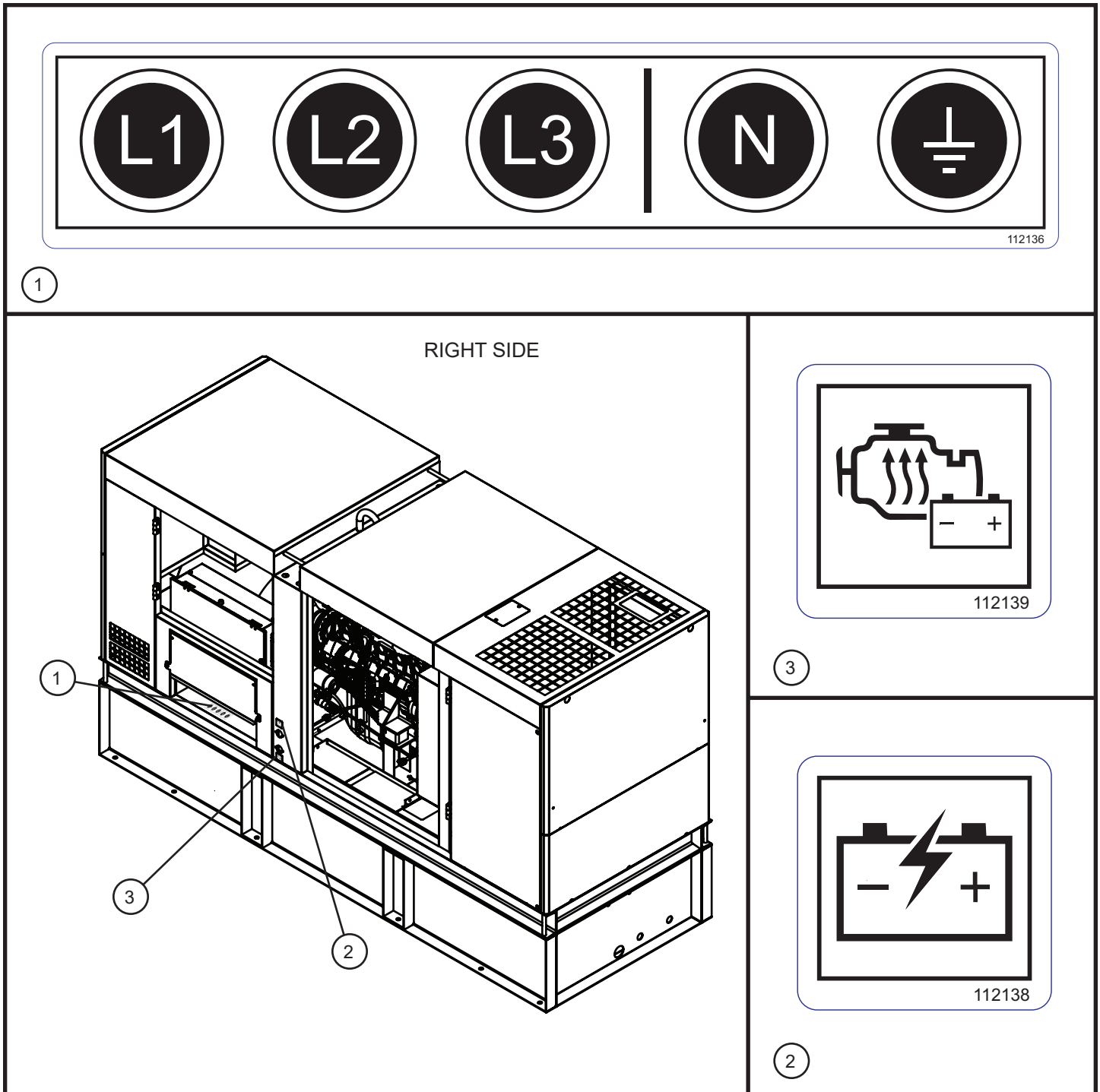

Maxi-Power 150

4.3 - Cam Lock and Arctic Package Decals

SN 27-000001 to 27-000099

Item	Allmand No.	Hokuetsu No.	Part Description	Qty.
1	112136	n/a	CAM LOCK MAXI-POWER DECAL	1
2	112138	n/a	BATTERY CHARGER DECAL	1
3	112139	n/a	ENGINE AND BATTERY HEATER DECAL	1

Allmand™

BRIGHTER. WARMER. SAFER.

Allmand Bros., Inc.
1502 West 4th Avenue
Holdrege, NE 68949
phone: (308) 995-4495 • toll free: (800) 562-1373
fax: (308) 995-5887

www.allmand.com



Reliability, performance, and integrity since 1938

13-0267